



8Kx8 Power-Switched and Reprogrammable PROM

Features

- CMOS for optimum speed/power
- Windowed for reprogrammability
- High speed
 - 20 ns (Commercial)
- Low power
 - 660 mW (Commercial)
- Super low standby power
 - Less than 85 mW when deselected
- EPROM technology 100% programmable
- 5V ±10% V_{CC}, commercial and military
- TTL-compatible I/O
- Direct replacement for 27C64 EPROMs

powers down into a low-power standby mode. It is packaged in a 600-mil-wide package. The reprogrammable packages are equipped with an erasure window; when exposed to UV light, these PROMs are erased and can then be reprogrammed. The memory cells utilize proven EPROM floating-gate technology and byte-wide intelligent programming algorithms.

The CY7C266 is a plug-in replacement for EPROM devices. The EPROM cell requires only 12.5V for the super voltage and low-current requirements allow for gang programming. The EPROM cells allow for each memory location to be tested 100%, as each location is written into, erased, and repeatedly exercised prior to encapsulation. Each PROM is also tested for AC performance to guarantee that after customer programming, the product will meet DC and AC specification limits.

Functional Description

The CY7C266 is a high-performance 8192-word by 8-bit CMOS PROM. When deselected, the CY7C266 automatically

Reading is accomplished by placing an active LOW signal on \overline{OE} and \overline{CE} . The contents of the memory location addressed by the address lines (A_0 through A_{12}) will become available on the output lines (O_0 through O_7).

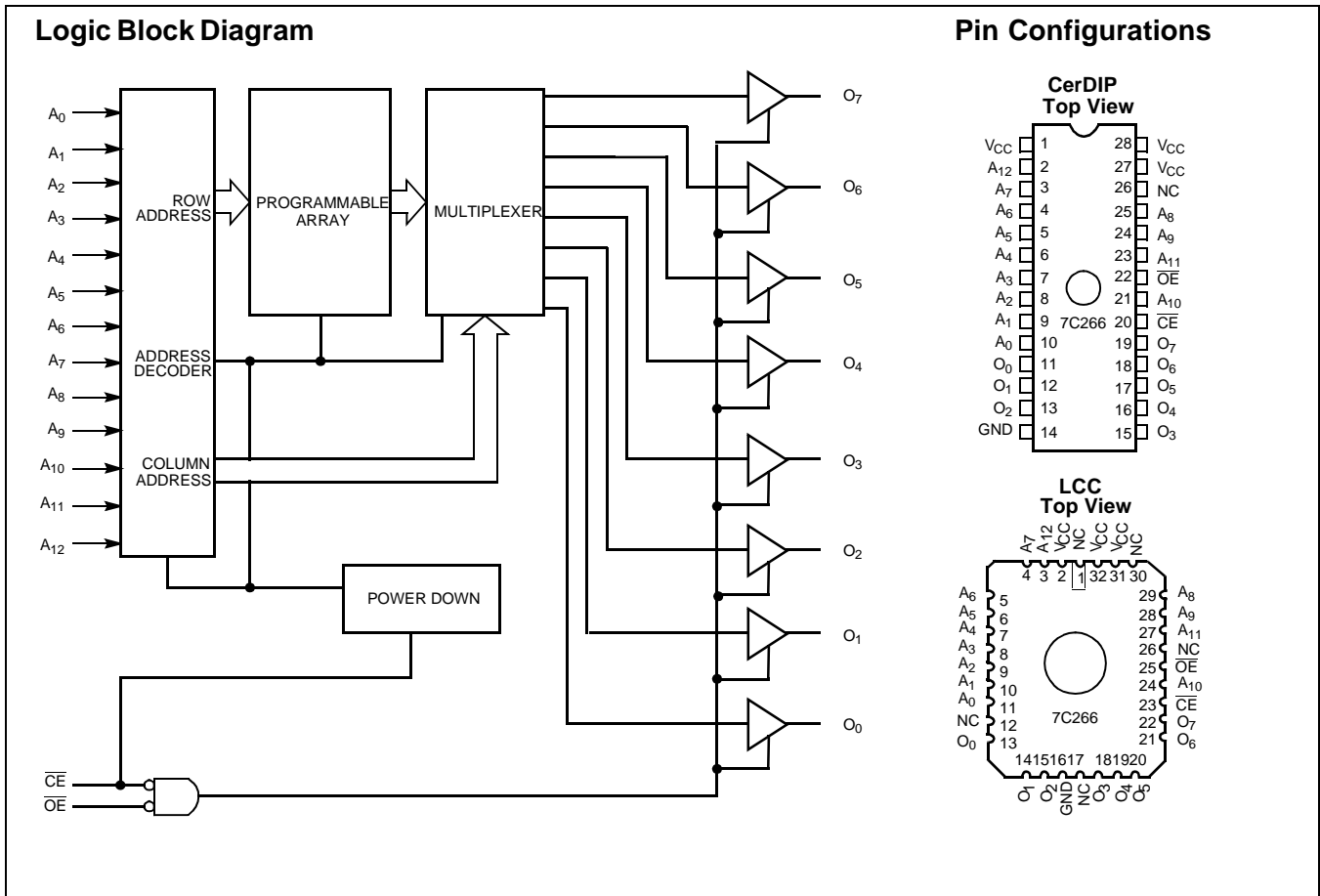

Selection Guide

		7C266-20	7C266-25	7C266-45	Unit
Maximum Access Time		20	25	45	ns
Maximum Operating Current	Commercial	120	120	100	mA
Maximum Standby Current	Commercial	15	15	15	mA

Maximum Ratings^[1]

(Above which the useful life may be impaired. For user guidelines, not tested.)

Storage Temperature -65°C to +150°C

Ambient Temperature with Power Applied..... -55°C to +125°C

Supply Voltage to Ground Potential (Pin 28 to Pin 14) -0.5V to +7.0V

DC Voltage Applied to Outputs in High Z State -0.5V to +7.0V

DC Input Voltage..... -3.0V to +7.0V

DC Program Voltage 13.0V

Static Discharge Voltage..... > 2001V (per MIL-STD-883, Method 3015)

Latch-Up Current..... > 200 mA

UV Exposure 7258 Wsec/cm²

Operating Range

Range	Ambient Temperature	V _{CC}
Commercial	0°C to +70°C	5V ± 10%

Electrical Characteristics Over the Operating Range^[2]

Parameter	Description	Test Conditions	7C266-20		7C266-25		Unit
			Min.	Max.	Min.	Max.	
V _{OH}	Output HIGH Voltage	V _{CC} = Min., I _{OH} = -2.0 mA	2.4		2.4		V
V _{OL}	Output LOW Voltage	V _{CC} = Min., I _{OL} = 8.0 mA		0.4		0.4	V
V _{IH}	Input HIGH Voltage		2.0		2.0		V
V _{IL}	Input LOW Voltage			0.8		0.8	V
I _{IX}	Input Current	GND ≤ V _{IN} ≤ V _{CC}	-10	+10	-10	+10	μA
V _{CD}	Input Diode Clamp Voltage		Note 3				
I _{OZ}	Output Leakage Current	V _{OL} ≤ V _{OUT} ≤ V _{OH} , Output Disabled	-40	+40	-40	+40	μA
I _{OS}	Output Short Circuit Current ^[3]	V _{CC} = Max., V _{OUT} = GND	-20	-90	-20	-90	mA
I _{CC}	Power Supply Current	V _{CC} = Max., V _{IN} = 2.0V, I _{OUT} = 0 mA		120		120	mA
I _{SB}	Standby Supply Current	Chip Enable Inactive, CE ≥ V _{IH} , I _{OUT} = 0 mA		15		15	mA

Notes:

1. The voltage on any input or I/O pin cannot exceed the power pin during power-up.
2. See the "Introduction to CMOS PROMs" section of the Cypress Data Book for general information on testing.
3. For test purposes, not more than one output at a time should be shorted. Short circuit test duration should not exceed 30 seconds.

Electrical Characteristics Over the Operating Range^[2] (continued)

Parameter	Description	Test Conditions	7C266-45		Unit
			Min.	Max.	
V _{OH}	Output HIGH Voltage	V _{CC} = Min., I _{OH} = -4.0 mA	2.4		V
V _{OL}	Output LOW Voltage	V _{CC} = Min., I _{OL} = 16.0 mA		0.4	V
V _{IH}	Input HIGH Voltage		2.0		V
V _{IL}	Input LOW Voltage			0.8	V
I _{IX}	Input Current	GND ≤ V _{IN} ≤ V _{CC}	-10	+10	mA
V _{CD}	Input Diode Clamp Voltage		Note 3		
I _{OZ}	Output Leakage Current	V _{OL} ≤ V _{OUT} ≤ V _{OH} , Output Disabled	-10	+10	mA
I _{OS}	Output Short Circuit Current ^[3]	V _{CC} = Max., V _{OUT} = GND	-20	-90	mA
I _{CC}	Power Supply Current	V _{CC} = Max., V _{IN} = 2.0V, I _{OUT} = 0 mA	Com'l	100	mA
I _{SB}	Standby Supply Current	Chip Enable Inactive, CE ≥ V _{IH} , I _{OUT} = 0 mA	Com'l	15	mA

Capacitance^[2]

Parameter	Description	Test Conditions	Max.	Unit
C _{IN}	Input Capacitance	T _A = 25°C, f = 1 MHz, V _{CC} = 5.0V	10	pF
C _{OUT}	Output Capacitance		10	pF

AC Test Loads and Waveforms

Test Load for -20 through -25 speeds

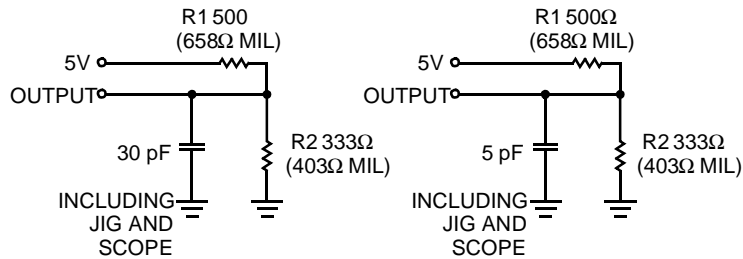

(a) Normal Load

(b) High Z Load

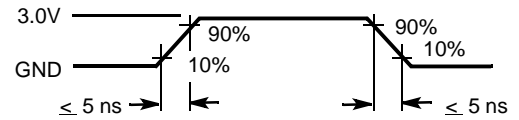

Equivalent to: THÉVENIN EQUIVALENT



Test Load for -35 through -45 speeds

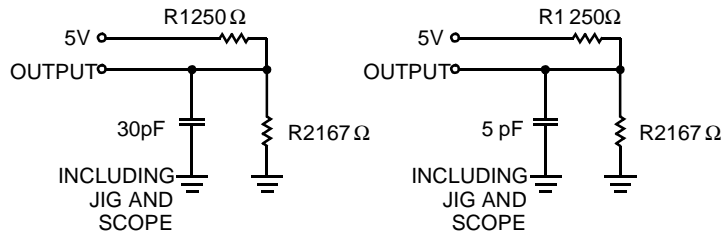

(c) Normal Load

(d) High Z Load

Equivalent to: THÉVENIN EQUIVALENT

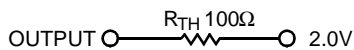

Switching Characteristics Over the Operating Range^[2]

Parameter	Description	7C266-20		7C266-25		7C266-45		Unit
		Min.	Max.	Min.	Max.	Min.	Max.	
t_{AA}	Address to Output Valid		20		25		45	ns
t_{HZCE}	Chip Enable Inactive to High Z		25		30		45	ns
t_{HZOE}	Output Enable Inactive to High Z		12		12		20	ns
t_{AOE}	Output Enable Active to Output Valid		12		12		20	ns
t_{ACE}	Chip Enable Active to Output Valid		25		30		45	ns
t_{OHA}	Data Hold from Address Change	3		3		3		ns
t_{PU}	Chip Enable Active to Power-up		25		30		45	ns
t_{PD}	Chip Enable Inactive to Power-down		25		30		45	ns

Erasure Characteristics

Wavelengths of light less than 4000 angstroms begin to erase the devices in the windowed package. For this reason, an opaque label should be placed over the window if the EPROM is exposed to sunlight or fluorescent lighting for extended periods of time.

The recommended dose of ultraviolet light for erasure is a wavelength of 2537 angstroms for a minimum dose (UV intensity multiplied by exposure time) of 25 Wsec/cm². For an ultraviolet lamp with a 12 mW/cm² power rating, the exposure time would be approximately 35 minutes. The CY7C266 needs to be within 1 inch of the lamp during erasure. Permanent damage may

result if the EPROM is exposed to high-intensity UV light for an extended period of time.

7258 Wsec/cm² is the recommended maximum dosage.

Programming Modes

Programming support is available from Cypress as well as from a number of third party software vendors. For detailed programming information, including a listing of software packages, please see the PROM Programming Information located at the end of this section. Programming algorithms can be obtained from any Cypress representative.

Table 1. Mode Selection

Mode	Pin Function ^[4, 5]								
	Normal Operation	A ₈	A ₉	A ₁₀	A ₁₁	A ₁₂	CE	OE	D ₇ -D ₀
Program	VFY	PGM	LAT	NA	NA	CE	V _{PP}	D ₇ -D ₀	
Read	A ₈	A ₉	A ₁₀	A ₁₁	A ₁₂	V _{IL}	V _{IL}	O ₇ -O ₀	
Standby	X	X	X	X	X	V _{IH}	X	Three-Stated	
Output Disable	A ₈	A ₉	A ₁₀	A ₁₁	A ₁₂	V _{IL}	V _{IH}	Three-Stated	
Program	V _{IHP}	V _{ILP}	V _{ILP}	V _{ILP}	V _{ILP}	V _{ILP}	V _{PP}	D ₇ -D ₀	
Program Verify	V _{ILP}	V _{IHP}	V _{ILP}	V _{ILP}	V _{ILP}	V _{ILP}	V _{PP}	O ₇ -O ₀	
Program Inhibit	V _{IHP}	V _{IHP}	V _{ILP}	V _{ILP}	V _{ILP}	V _{ILP}	V _{PP}	Three-Stated	
Blank Check	V _{ILP}	V _{IHP}	V _{ILP}	V _{ILP}	V _{ILP}	V _{ILP}	V _{PP}	O ₇ -O ₀	

Notes:

4. X = "don't care" but must not exceed V_{CC} + 5%.
5. Address A₈-A₁₂ must be latched through lines A₀-A₄ in Programming modes.

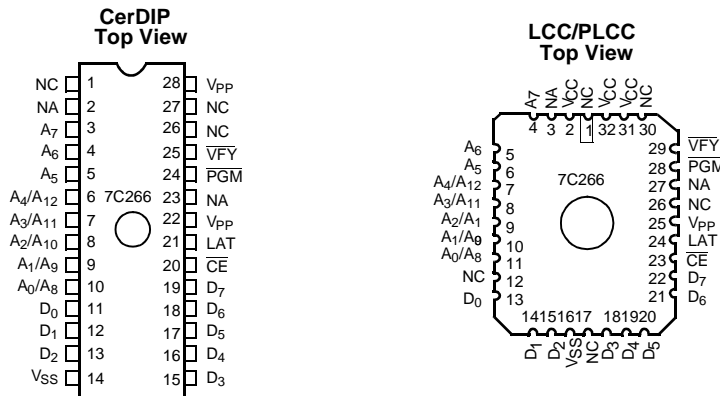
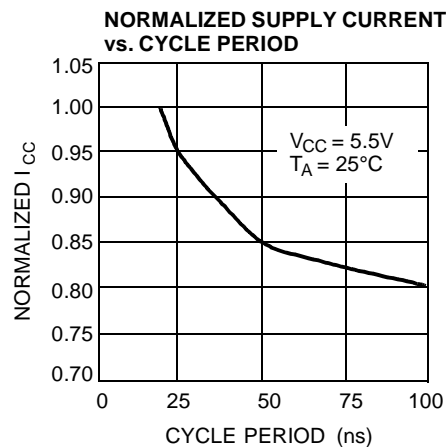
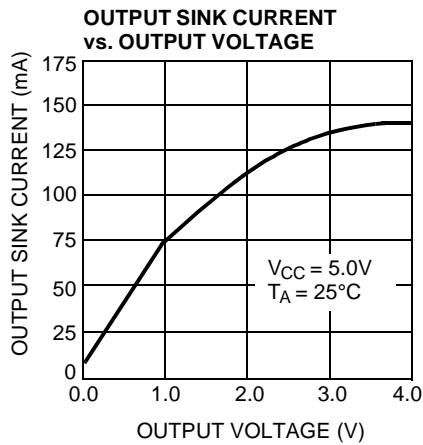
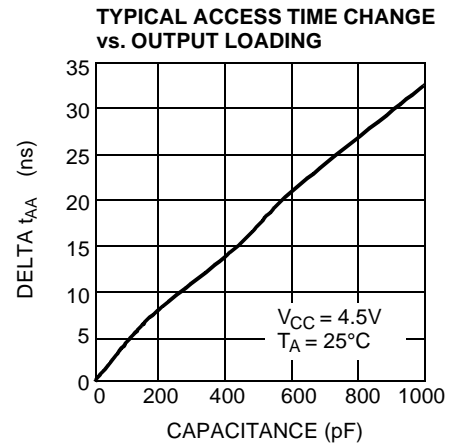
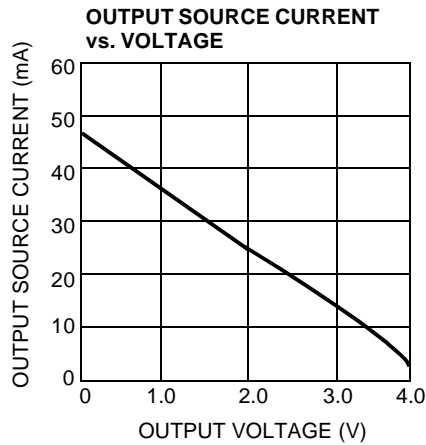
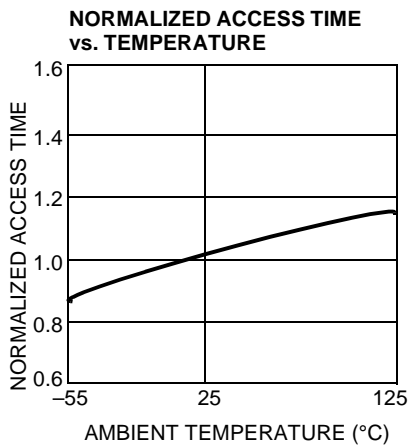
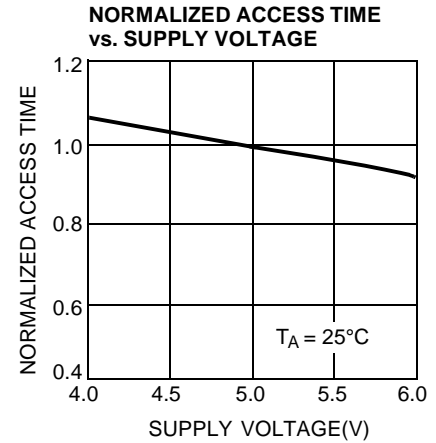
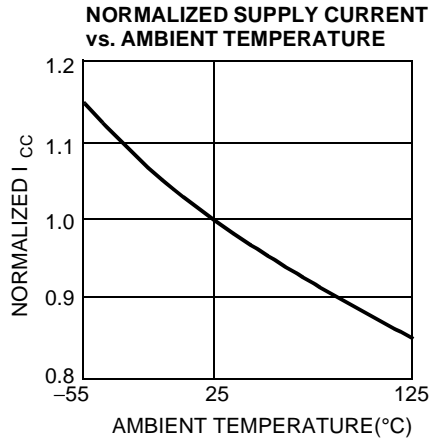
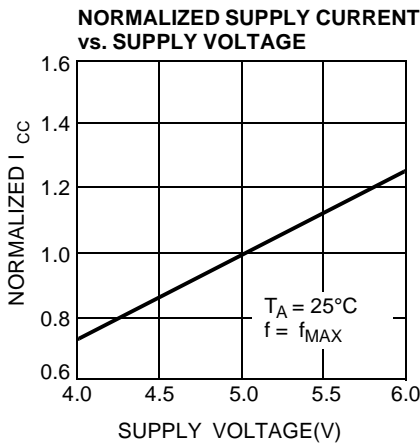

Figure 1. Programming Pinout

Typical DC and AC Characteristics

Ordering Information¹

Speed (ns)	Ordering Code	Package Name	Package Type	Operating Range
20	CY7C266-20JC	J64	28-Lead Plastic Leaded Chip Carrier	Commercial
	CY7C266-20WC	W16	28-Lead (600-Mil) Windowed CerDIP	
25	CY7C266-25JC	J64	28-Lead Plastic Leaded Chip Carrier	Commercial
45	CY7C266-45PC	P15	28-Lead (600-Mil) Molded DIP	Commercial

Package Diagrams

28-Lead (600-Mil) CerDIP D16
MIL-STD-1835 D-10 Config. A

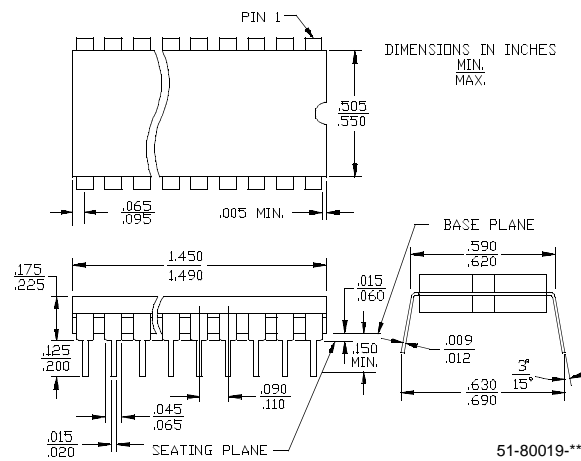

Package Diagrams (continued)

32-Pin Rectangular Leadless Chip Carrier L55

MIL-STD-1835 C-12

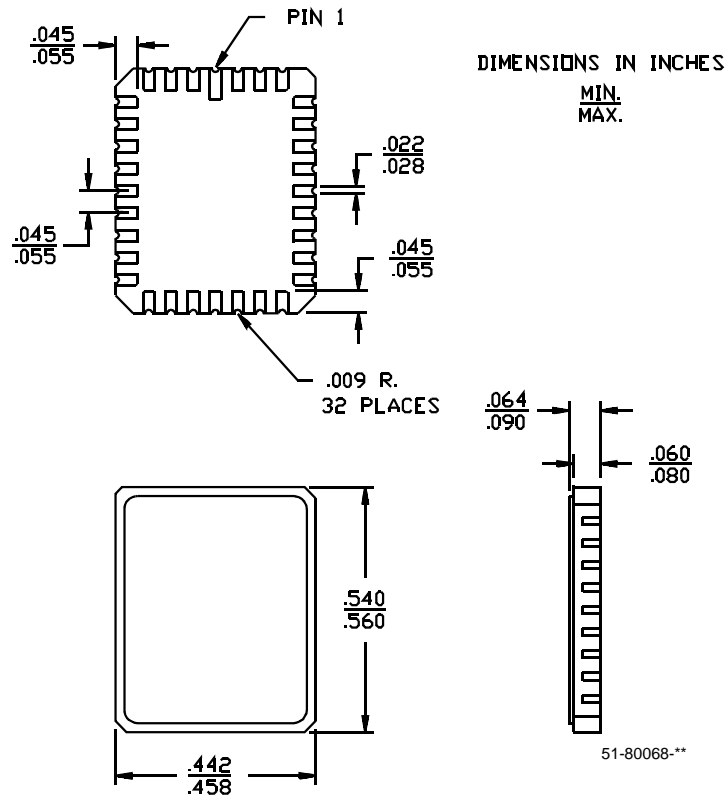

28-Lead (600-Mil) Molded DIP P15

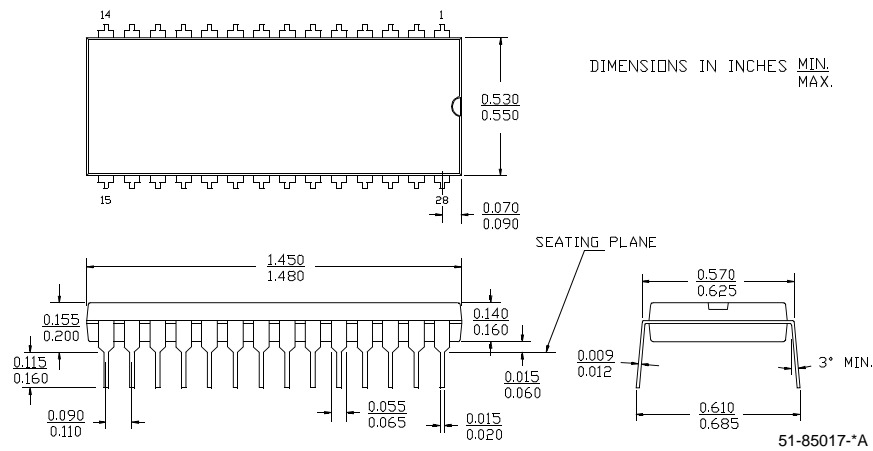

Package Diagrams (continued)

32-Pin Windowed Rectangular Leadless Chip Carrier Q55
MIL-STD-1835 C-12

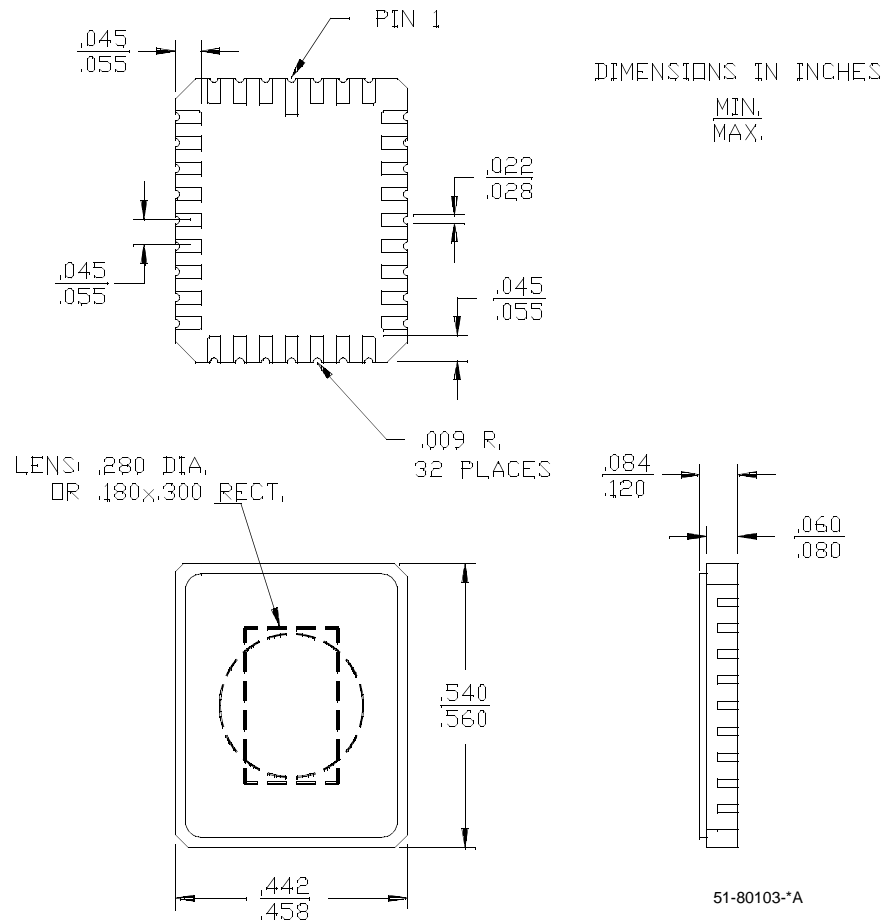

Package Diagrams (continued)

28-Lead (600-Mil) Windowed CerDIP W16
MIL-STD-1835 D-10 Config. A

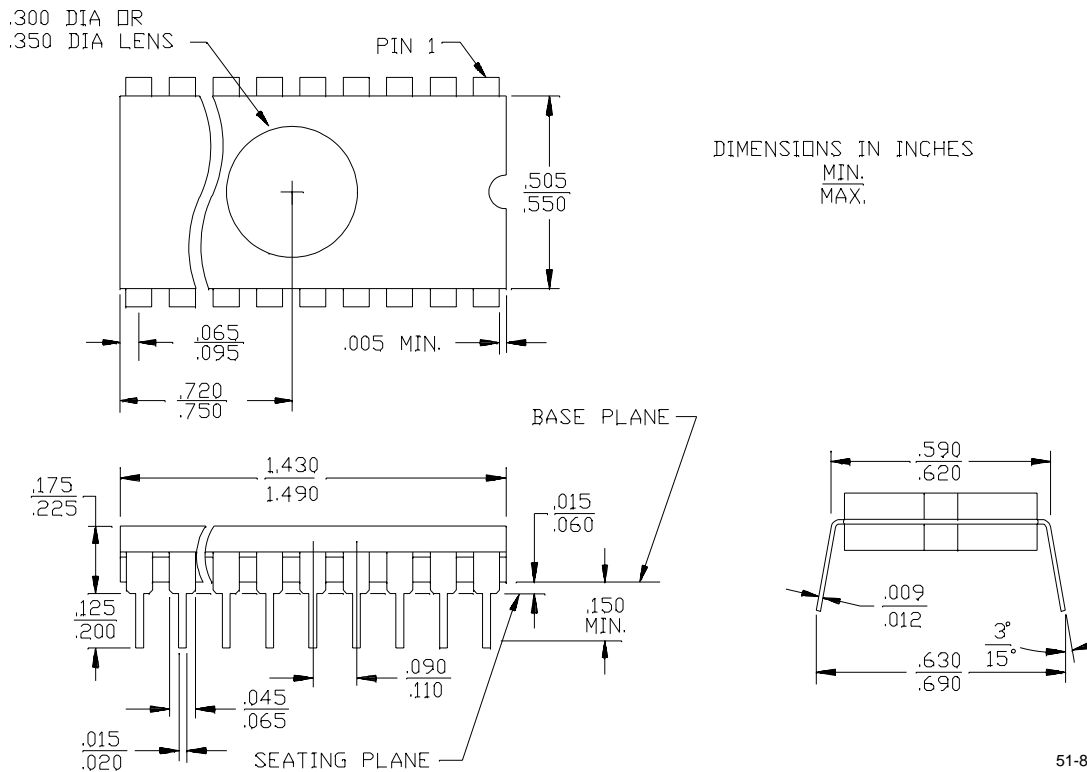

51-80020-**

All product and company names mentioned in this document may be the trademarks of their respective holders.

Document History Page

Document Title: CY7C266 8K x 8 Power Switched and Reprogrammable PROM				
Document Number: 38-04005				
REV.	ECN NO.	Issue Date	Orig. of Change	Description of Change
**	113861	03/08/02	DSG	Change from Spec number: 38-00086 to 38-04005
*A	118897	10/09/02	GBI	Update ordering information
*B	122246	12/27/02	RBI	Add power up requirements to Operating Conditions information

This datasheet has been downloaded from:

www.DatasheetCatalog.com

Datasheets for electronic components.



LittleDiode supplies new, hard to find or obsolete electronic components and semiconductors all over the world.

With over two million different components listed you are sure to find the part you need.

Feel free to visit us today at our online store:

LittleDiode.com

Looking forward to providing you with the best possible service.