

Features

- CMOS for optimum speed/power
- High speed
 - 25 ns (Commercial)
- Low power
 - 495 mW (Commercial)
- EPROM technology 100% programmable
- Slim 300-mil or standard 600-mil DIP or 28-pin LCC
- 5V ±10% V_{CC}, commercial and military
- TTL-compatible I/O
- Direct replacement for bipolar PROMs
- Capable of withstanding >2001V static discharge

Functional Description

The CY7C281A is a high-performance 1024-word by 8-bit CMOS PROMs. It is packaged in 300-mil and 600-mil-wide

packages respectively. The CY7C281A is also available in a 28-pin leadless chip carrier. The memory cells utilize proven EPROM floating-gate technology and byte-wide intelligent programming algorithms.

The CY7C281A is a plug-in replacements for bipolar devices and offer the advantages of lower power, superior performance, and programming yield. The EPROM cell requires only 12.5V for the super voltage, and low current requirements allow for gang programming. The EPROM cells allow each memory location to be tested 100% because each location is written into, erased, and repeatedly exercised prior to encapsulation. Each PROM is also tested for AC performance to guarantee that after customer programming, the product will meet DC and AC specification limits.

Reading is accomplished by placing an active LOW signal on CS₁ and CS₂, and active HIGH signals on CS₃ and CS₄. The contents of the memory location addressed by the address lines (A₀–A₉) will become available on the output lines (O₀–O₇).

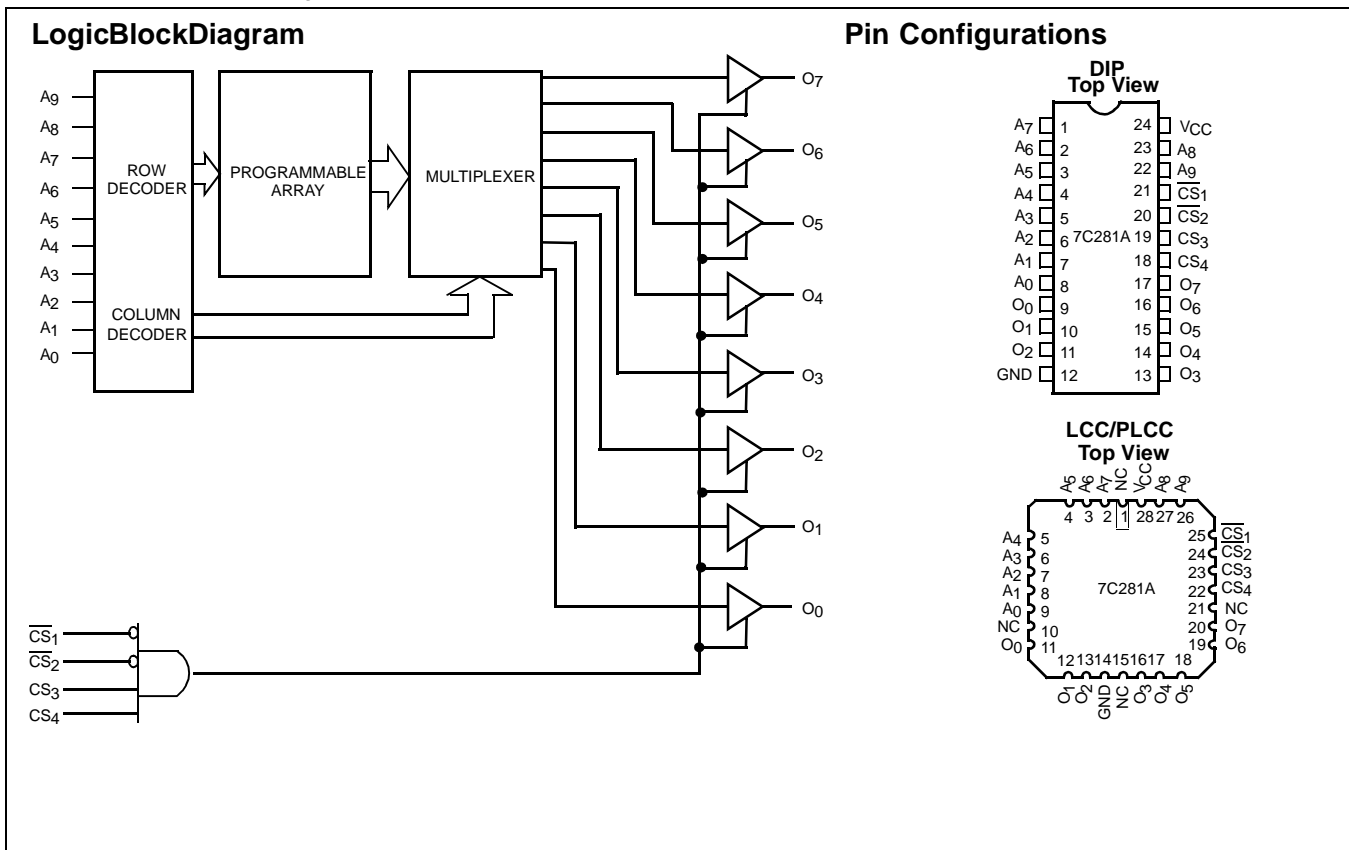
Selection Guide

| | | 7C281A-25 | 7C281A-30 | Unit |
|---------------------------|------------|-----------|-----------|------|
| Maximum Access Time | | 25 | 30 | ns |
| Maximum Operating Current | Commercial | 100 | 100 | mA |

Maximum Ratings¹

(Above which the useful life may be impaired. For user guidelines, not tested.)

| | |
|--|-----------------|
| Storage Temperature | -65°C to +150°C |
| Ambient Temperature with Power Applied..... | -55°C to +125°C |
| Supply Voltage to Ground Potential (Pin 24 to Pin 12)..... | -0.5V to +7.0V |
| DC Voltage Applied to Outputs in High Z State | -0.5V to +7.0V |
| DC Input Voltage | -3.0V to +7.0V |

| | |
|--|---------------------------------------|
| DC Program Voltage (Pins 18, 20) | 13.0V |
| Static Discharge Voltage..... | >2001V (per MIL-STD-883, Method 3015) |
| Latch-Up Current..... | >200 mA |

Operating Range

| Range | Ambient Temperature | V _{CC} |
|------------|---------------------|-----------------|
| Commercial | 0°C to +70°C | 5V ±10% |

Electrical Characteristics Over the Operating Range^{2,3}

| Parameter | Description | Test Conditions | 7C281A-25 | | 7C281A-30 | | Unit |
|------------------|---|--|-----------|------|-----------|------|------|
| | | | Min. | Max. | Min. | Max. | |
| V _{OH} | Output HIGH Voltage | V _{CC} = Min., I _{OH} = -4.0 mA | 2.4 | | 2.4 | | V |
| V _{OL} | Output LOW Voltage | V _{CC} = Min., I _{OL} = 16.0 mA | | 0.4 | | 0.4 | V |
| V _{IH} | Input HIGH Level | Guaranteed Input Logical HIGH Voltage for All Inputs | 2.0 | | 2.0 | | V |
| V _{IL} | Input LOW Level | Guaranteed Input Logical LOW Voltage for All Inputs | | 0.8 | | 0.8 | V |
| I _{IX} | Input Current | GND ≤ V _{IN} ≤ V _{CC} | -10 | +10 | -10 | +10 | μA |
| I _{OZ} | Output Leakage Current | GND ≤ V _{OUT} ≤ V _{CC} , Output Disabled | -10 | +10 | -10 | +10 | μA |
| I _{OS} | Output Short Circuit Current ⁴ | V _{CC} = Max., V _{OUT} = GND | -20 | -90 | -20 | -90 | mA |
| I _{CC} | Power Supply Current | V _{CC} = Max., I _{OUT} = 0 mA | | 100 | | 100 | mA |
| V _{PP} | Program Voltage | | 12 | 13 | 12 | 13 | V |
| V _{IHP} | Program HIGH Voltage | | 3.0 | | 3.0 | | V |
| V _{ILP} | Program LOW Voltage | | | 0.4 | | 0.4 | V |
| I _{PP} | Program Supply Current | | | 50 | | 50 | mA |

Capacitance³

| Parameter | Description | Test Conditions | Max. | Unit |
|------------------|--------------------|---|------|------|
| C _{IN} | Input Capacitance | T _A = 25°C, f = 1 MHz, V _{CC} = 5.0V | 10 | pF |
| C _{OUT} | Output Capacitance | | 10 | pF |

Notes:

- The voltage on any input or I/O pin cannot exceed the power pin during power-up.
- See the last page of this specification for Group A subgroup testing information.
- See "Introduction to CMOS PROMs" in this Data Book for general information on testing.
- For test purposes, not more than one output at a time should be shorted. Short circuit test duration should not exceed 30 seconds.

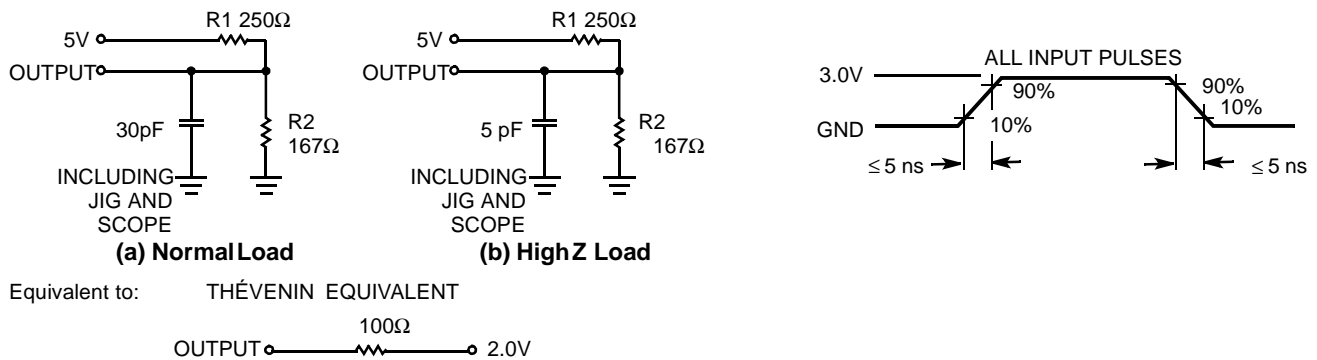
AC Test Loads and Waveforms^[3]

Switching Characteristics Over the Operating Range^[1,3]

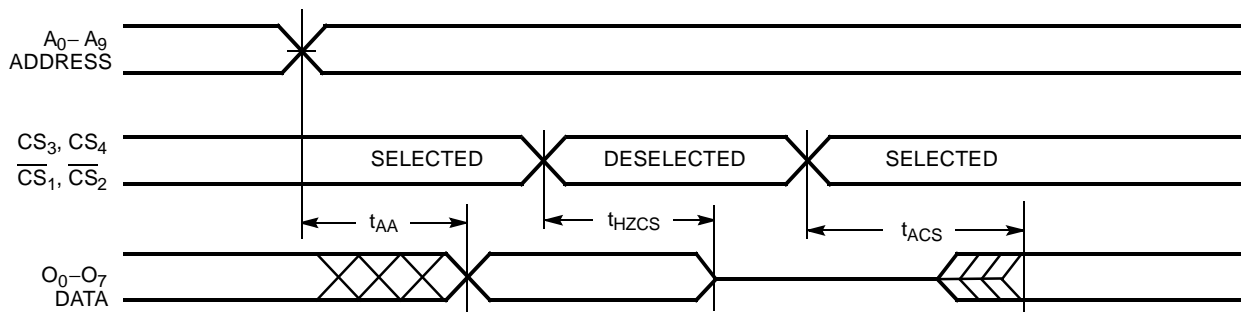
| Parameter | Description | 7C281A-25 | | 7C281A-30 | | Unit |
|------------|------------------------------------|-----------|------|-----------|------|------|
| | | Min. | Max. | Min. | Max. | |
| t_{AA} | Address to Output Valid | | 25 | | 30 | ns |
| t_{HZCS} | Chip Select Inactive to High Z | | 15 | | 20 | ns |
| t_{ACS} | Chip Select Active to Output Valid | | 15 | | 20 | ns |

Switching Waveforms

Programming Information

Programming support is available from Cypress as well as from a number of third party software vendors. For detailed

programming information, including a listing of software packages, please see the PROM Programming Information located at the end of this section. Programming algorithms can be obtained from any Cypress representative.

Table 1. Mode Selection

| Mode | Pin Function ^[5] | | | | | | |
|---------------------|-----------------------------|--------------------------------|------------------|------------------|-----------------|------------------|--------------------------------|
| | Read or Output Disable | A ₉ -A ₀ | CS ₄ | CS ₃ | CS ₂ | CS ₁ | O ₇ -O ₀ |
| | Other | A ₉ -A ₀ | PGM | VFY | V _{PP} | CS ₁ | D ₇ -D ₀ |
| Read | | A ₉ -A ₀ | V _{IH} | V _{IH} | V _{IL} | V _{IL} | O ₇ -O ₀ |
| Output Disable | | A ₉ -A ₀ | X | X | V _{IH} | X | High Z |
| Output Disable | | A ₉ -A ₀ | X | V _{IL} | X | X | High Z |
| Output Disable | | A ₉ -A ₀ | V _{IL} | X | X | X | High Z |
| Output Disable | | A ₉ -A ₀ | X | X | X | V _{IH} | High Z |
| Program | | A ₉ -A ₀ | V _{ILP} | V _{IHP} | V _{PP} | V _{ILP} | D ₇ -D ₀ |
| Program Verify | | A ₉ -A ₀ | V _{IHP} | V _{ILP} | V _{PP} | V _{ILP} | O ₇ -O ₀ |
| Program Inhibit | | A ₉ -A ₀ | V _{IHP} | V _{IHP} | V _{PP} | V _{ILP} | High Z |
| Intelligent Program | | A ₉ -A ₀ | V _{ILP} | V _{IHP} | V _{PP} | V _{ILP} | D ₇ -D ₀ |
| Blank Check | | A ₉ -A ₀ | V _{IHP} | V _{ILP} | V _{PP} | V _{ILP} | Zeros |

Note:

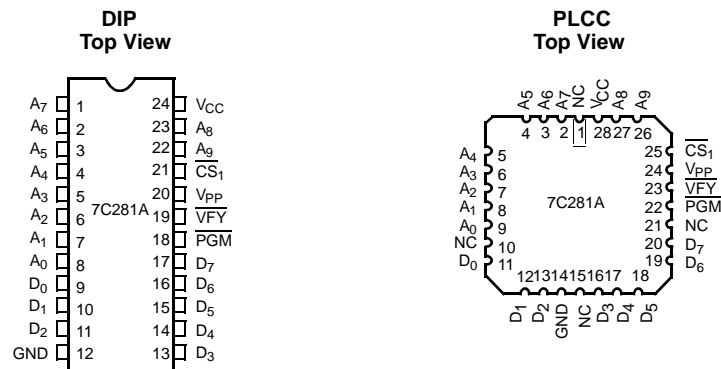
 5. X = "don't care" but not to exceed V_{CC} ±5%.

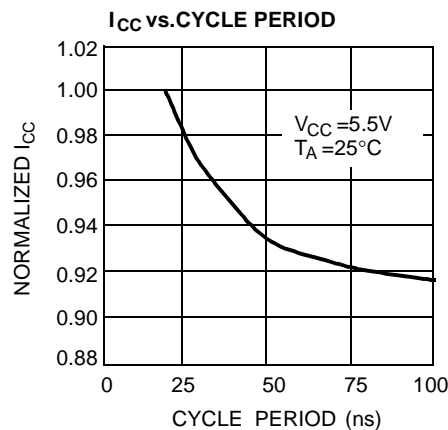
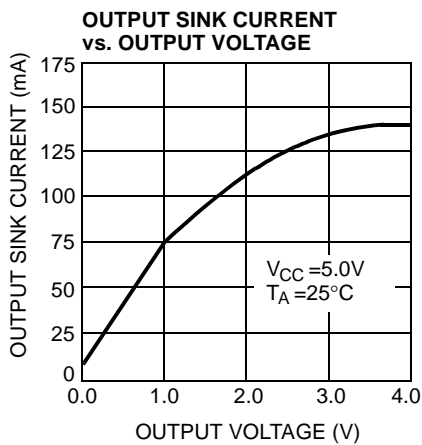
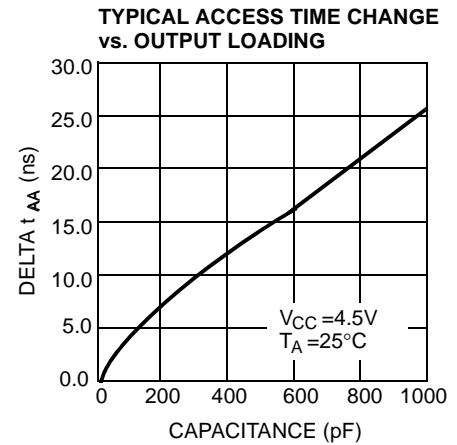
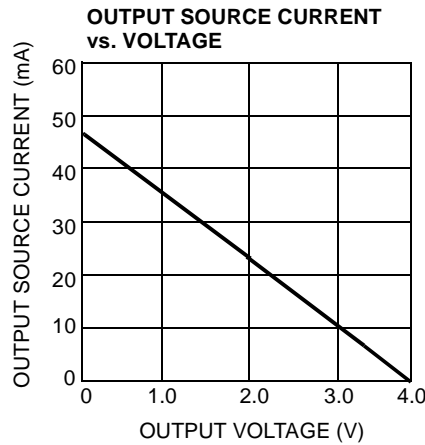
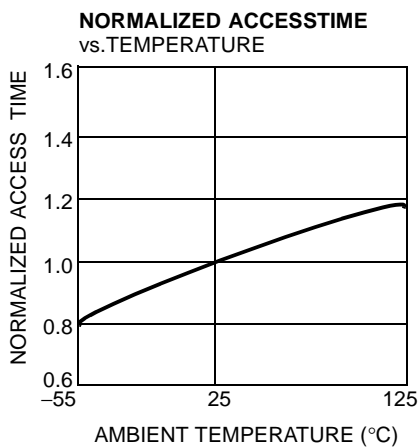
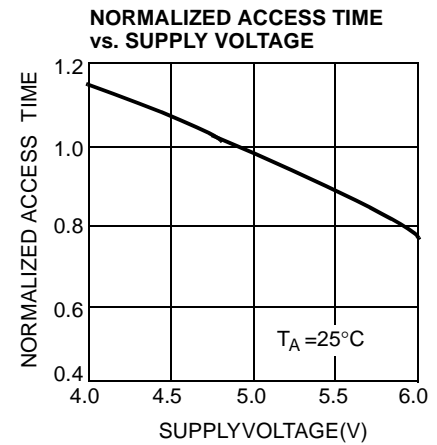
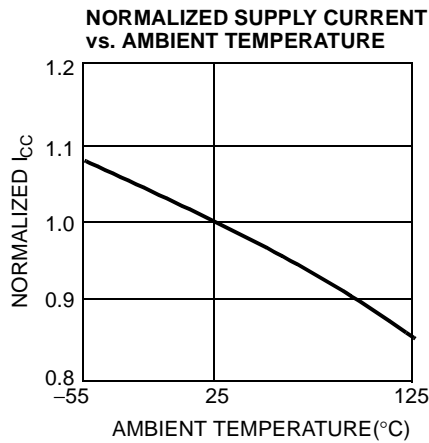
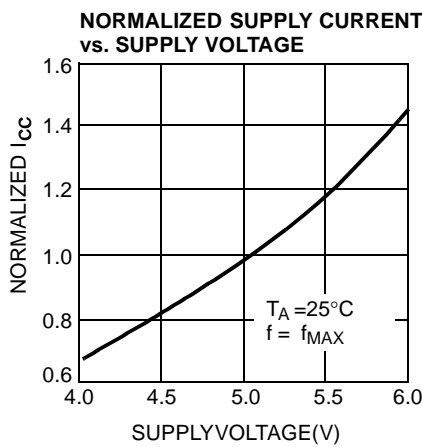
Figure 1. Programming Pinouts

Typical DC and AC Characteristics

Ordering Information

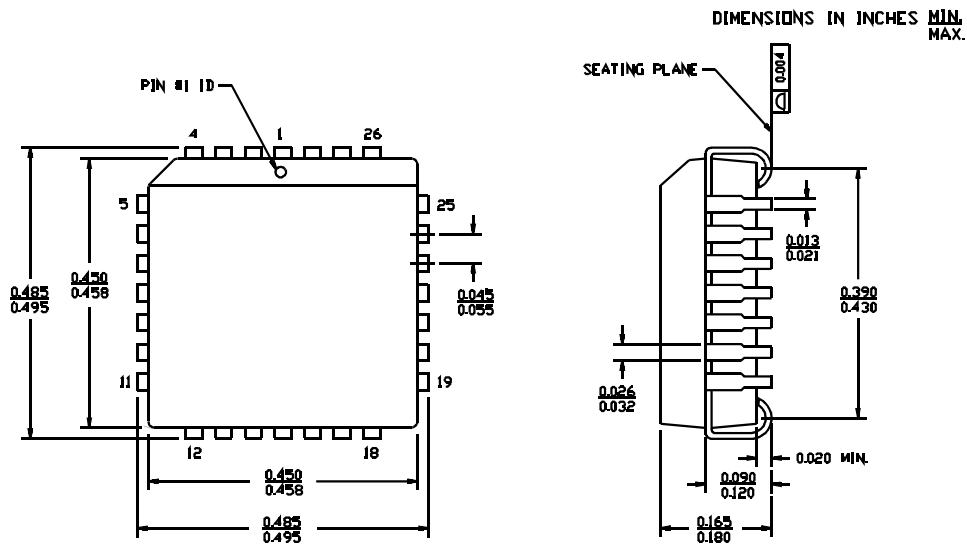
| Speed (ns) | Ordering Code | Package Name | Package Type | Operating Range |
|------------|---------------|--------------|-------------------------------------|-----------------|
| 25 | CY7C281A-25JC | J64 | 28-Lead Plastic Leaded Chip Carrier | Commercial |
| | CY7C281A-25PC | P13 | 24-Lead (300-Mil) Molded DIP | |
| 30 | CY7C281A-30JC | J64 | 28-Lead Plastic Leaded Chip Carrier | Commercial |
| | CY7C281A-30PC | P13 | 24-Lead (300-Mil) Molded DIP | |

Package Diagrams
28-Lead Plastic Leaded Chip Carrier J64

Package Diagrams (continued)
24-Lead (300-Mil) Molded DIP P13/P13A

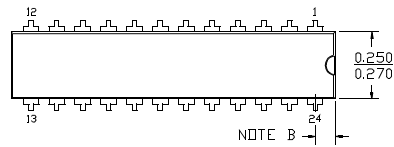
 DIMENSIONS IN INCHES MIN.
MAX.

| | P 13 | P 13A |
|--------|----------------|----------------|
| NOTE A | 1.170 1.200 | 1.230 1.260 |
| NOTE B | 0.030 0.050 | 0.060 0.080 |

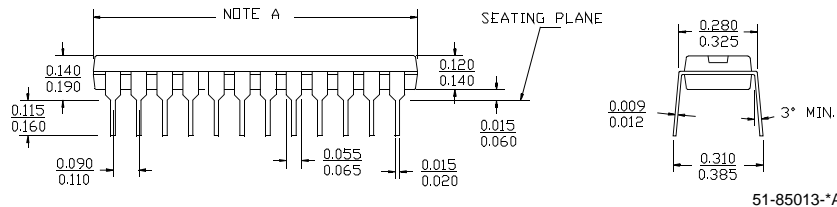

51-85013-*A

All product and company names mentioned in this document may be the trademarks of their respective holders.

Document History Page

| Document Title: CY7C281A 1K x 8 PROM | | | | |
|---|----------------|-------------------|------------------------|--|
| Document Number: 38-04003 | | | | |
| REV. | ECN NO. | Issue Date | Orig. of Change | Description of Change |
| ** | 113859 | 03/06/02 | DSG | Change from Spec number: 38-00227 to 38-04003 |
| *A | 118902 | 10/09/02 | GBI | Update ordering information |
| *B | 122244 | 12/27/02 | RBI | Add power up requirements to Maximum ratings information |



LittleDiode supplies new, hard to find or obsolete electronic components and semiconductors all over the world.

With over two million different components listed you are sure to find the part you need.

Feel free to visit us today at our online store:

LittleDiode.com

Looking forward to providing you with the best possible service.