

TA2092N

POWER DRIVER IC FOR CD PLAYER

The TA2092N is a power driver IC developed for CD players.

This IC have built-in 4 channel BTL power amplifiers which drives focus-coil, tracking-coil for 3-beam pick-up head, disc motor and feed motor.

FEATURES

- 4 channel BTL linear drivers
- Fixed voltage gain : $G_V = 15\text{dB}$ (Typ.)
- High output power
 - : $V_{OM1} = 5V_{p-p}$ (Typ.) @ $V_{CC} = 5V, R_L = 5\Omega$
 - : $V_{OM2} = 6V_{p-p}$ (Typ.) @ $V_{CC} = 6V, R_L = 5\Omega$
- Thermal shutdown circuit
- Input reference voltage short protection
- Operating Voltage range
 - : $V_{CC}(\text{opr}) = 4.0 \sim 10.0V$ ($T_a = 25^\circ\text{C}$)

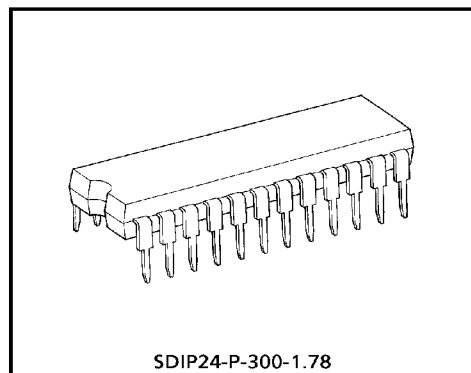

SDIP24-P-300-1.78

Weight : 1.2g (Typ.)

BLOCK DIAGRAM

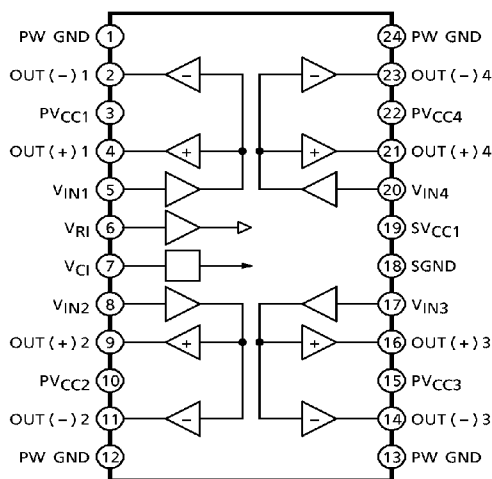

980508EBA2

● TOSHIBA is continually working to improve the quality and the reliability of its products. Nevertheless, semiconductor devices in general can malfunction or fail due to their inherent electrical sensitivity and vulnerability to physical stress. It is the responsibility of the buyer, when utilizing TOSHIBA products, to observe standards of safety, and to avoid situations in which a malfunction or failure of a TOSHIBA product could cause loss of human life, bodily injury or damage to property. In developing your designs, please ensure that TOSHIBA products are used within specified operating ranges as set forth in the most recent products specifications. Also, please keep in mind the precautions and conditions set forth in the TOSHIBA Semiconductor Reliability Handbook.

TERMINAL EXPLANATION

TERMINAL No.	SYMBOL	FUNCTION	EQUIVALENT CIRCUIT
1	PW GND	Power GND ● Connected to substrate. ● ①, ⑫, ⑬, ⑭ pin are connected inside.	
2	OUT (-) 1	Inverted output for CH1	
3	PVCC1	Supply terminal of output stage for CH1 ● Supply terminal of output stage are not connected to other channel terminal.	
4	OUT (+) 1	Non-inverted output for CH1	
5	V _{IN1}	Input for CH1 ● Not biased inside	
6	V _{RI}	Input reference voltage ● Under condition of $V_{RI} \leq 1.8V$, internal bias circuit is shut off. ● No signal input condition : $V_{RI} = V_{IN}$	
7	V _{CI}	Output reference voltage ● $V_{OUT} = V_{CI} = (V_{CC} - V_F) / 2$	
8	V _{IN2}	Input for CH2	Same as channel 1
9	OUT (+) 2	Non-inverted output for CH2	
10	PVCC2	Supply terminal of output stage for CH2	
11	OUT (-) 2	Inverted output for CH2	
12	PW GND	Power GND	Same as channel 1
13	PW GND	Power GND	
14	OUT (-) 3	Inverted output for CH3	
15	PVCC3	Supply terminal of output stage for CH3	
16	OUT (+) 3	Non-inverted output for CH3	Same as channel 1
17	V _{IN3}	Input for CH3	
18	S GND	Supply terminal of small signal GND	
19	S VCC	Small signal GND	
20	V _{IN4}	Input for CH4	Same as channel 1
21	OUT (+) 4	Non-inverted output for CH4	
22	PVCC4	Supply terminal of output stage for CH4	
23	OUT (-) 4	Inverted output for CH4	
24	PW GND	Power GND	

980508EBA2'

- The products described in this document are subject to foreign exchange and foreign trade laws.
- The information contained herein is presented only as a guide for the applications of our products. No responsibility is assumed by TOSHIBA CORPORATION for any infringements of intellectual property or other rights of the third parties which may result from its use. No license is granted by implication or otherwise under any intellectual property or other rights of TOSHIBA CORPORATION or others.
- The information contained herein is subject to change without notice.

MAXIMUM RATINGS ($T_a = 25^\circ\text{C}$)

CHARACTERISTIC	SYMBOL	RATING	UNIT
Supply Voltage	V_{CC}	14	V
Power Dissipation	P_D (Note 1)	(2) (Note 2)	W
Operating Temperature	T_{opr}	-30~85	$^\circ\text{C}$
Storage Temperature	T_{stg}	-55~150	$^\circ\text{C}$

(Note 1) : Mounted on 50mm×50mm×1.6mm size board with copper area 60% over.

(Note 2) : Derated above $T_a = 25^\circ\text{C}$, in the proportion of 62.5mW/ $^\circ\text{C}$.

ELECTRICAL CHARACTERISTICS

(Unless otherwise specified, $V_{CC} = 5\text{V}$, $R_L = 5\Omega$, $R_g = 620\Omega$, $V_{RI} = 2.1\text{V}$, $f = 1\text{kHz}$, $T_a = 25^\circ\text{C}$)

CHARACTERISTIC	SYMBOL	TEST CIR-CUIT	TEST CONDITION	MIN.	TYP.	MAX.	UNIT
Operating Voltage	V_{CC}	—	—	4.0	—	10.0	V
Quiescent Current	I_{CCQ}	—	$V_{in} = 0$, $R_L = \text{OPEN}$	20	35	60	mA
Input Offset Current	I_{IN}	—	$V_{IN} = 2.1\text{V}$	—	250	800	nA
V_{RI} Terminal Offset Current	I_{I0}	—	$V_{RI} = 2.1\text{V}$	—	35	120	μA
Output Offset Voltage	V_O OS1	—	$V_{CC} = 5\text{V}$, $R_g = 0\Omega$	-30	—	30	mV
	V_O OS2	—	$V_{CC} = 8\text{V}$, $R_g = 0\Omega$	-50	—	50	
	V_O OS3	—	$V_{CC} = 12\text{V}$, $R_g = 0\Omega$	-100	—	100	
Reference Output Voltage	V_{OUT}	—	—	—	2.1	—	V
Maximum Output Voltage	V_{OM1}	—	$V_{CC} = 5\text{V}$	4.0	5.0	—	V_{p-p}
	V_{OM2}	—	$V_{CC} = 6\text{V}$	5.0	6.0	—	
Voltage Gain	G_V	—	$V_{in} = 100\text{mV}_{rms}$	14.5	15.5	16.5	dB
Frequency Response	f_c	—	$V_{in} = 100\text{mV}_{rms}$	—	100	—	kHz
Total Harmonic Distortion	THD	—	$V_{in} = 100\text{mV}_{rms}$	—	-50	—	dB
Slew Rate	S.R.	—	$V_{out} = 2V_{p-p}$	—	1.0	—	V/ μs
Cross Talk	C.T.	—	$V_{out} = 1V_{rms}$	—	-60	—	dB
Ripple Rejection Ratio	R.R.	—	$f_{rip} = 100\text{Hz}$, $V_{rip} = 100\text{mV}_{rms}$	—	-60	—	dB
Thermal Shut Down Temperature	T_{TSD}	—	Chip temperature	—	150	—	$^\circ\text{C}$
$V_{RI} \sim \text{GND}$ Short Protection Voltage	$V_{RI OFF}$	—	—	1.4	1.6	1.8	V

TEST CIRCUIT

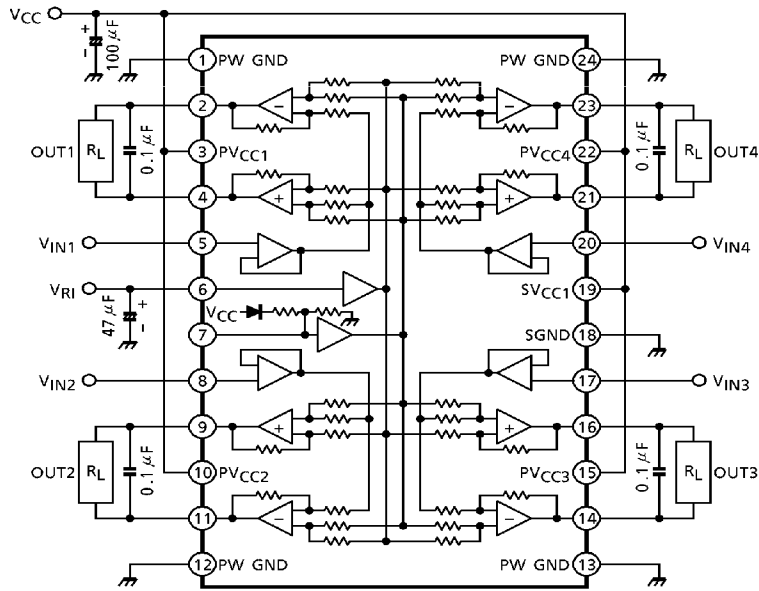

PRECAUTION USE

- Input Stage
 - Input stages are consisted of differential circuit of NPN Tr, and have built-in IB compensation circuit.
- Built-in Driver
 - Each channel driver consists of BTL configuration linear amplifier.
 - Voltage gain is fixed : $G_V = 15.5\text{dB}$ (Typ.)
 - Voltage loss for output stage is $2V_{BE} = V_{CE}(\text{sat})$ for positive cycle, $V_{CE}(\text{sat})$ for negative cycle, because of no-bootstrap circuit. So, output DC voltage is designed as less than $1/2V_{CC}$.
- V_{RI} Terminal
 - V_{RI} is reference voltage terminal for input signal.
 - If reference voltage from servo IC drop less than 1.8V, protection circuit operates and shut off bias circuit inside. This operation is to prevent load from moving undesireably in case of V_{RI} drop for accident or some reason.
- V_{CI} Terminal
 - Output DC voltage is determined by circuit of this terminal inside as ;
$$V_{CI} = V_{OUT}(\text{DC}) = (V_{CC} - V_F) / 2$$
 - Output signal dynamic range is depend on V_{CC} . On the other hand, input signal dynamic range is determined by V_{RI} as mentioned and voltage gain is fixed inside. So, maximum output voltage does not increase as V_{CC} increases.
 - Because of BTL configuration, Ripple Rejection Ratio does not improve not much when capacitor is connected to V_{CI} terminal to GND.
- GND
 - Large signal GND is for output stage and small signal GND is for stages from input circuit to pre-output stage.
 - These GND pins are not connected inside.
 - The heat of power dissipation is transferred to PCB, through these PW-GND Pin, because, ①, ⑫, ⑬, ⑭ pin are connected each other and to substrate of Pellet to connected copper foil area as large as possible.
- Oscillation preventive capacitor
 - We recommend to use the capacitor of $0.1\mu\text{F}$, between each output terminals. But perform the temperature test to check the oscillation allowance, since the oscillation allowance is varied according to the causes described below.
 - 1) Supply voltage
 - 2) Ambient temperature
 - 3) Load impedance
 - 4) Capacity value of condenser
 - 5) Kind of condenser
 - 6) Layout of Printed board
 - We recommend to connect Pass-condenser, which is about 10 to $100\mu\text{F}$ between V_{RI} terminal and GND.
- V_{CI} terminal is recommend to use "OPEN".

OUTLINE DRAWING
SDIP24-P-300-1.78

Unit : mm

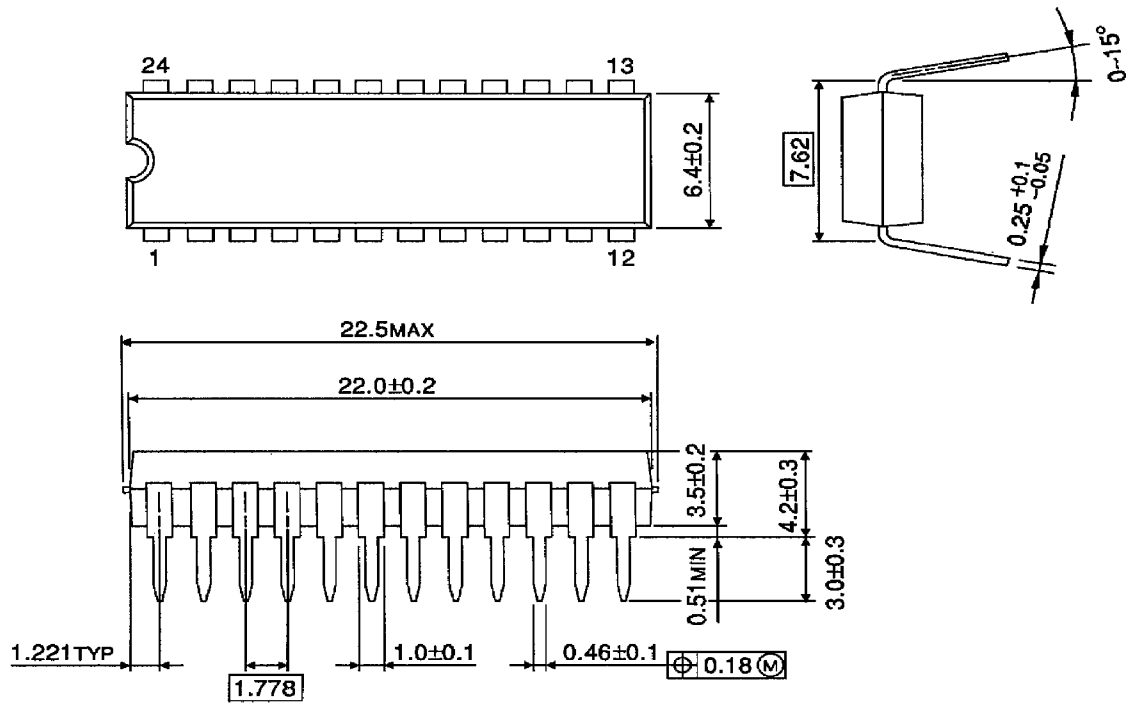

Weight : 1.2g (Typ.)