

## PRECISION SINGLE OPERATIONAL AMPLIFIERS

- FREQUENCY COMPENSATION WITH A SINGLE 30pF CAPACITOR
- OPERATION FROM  $\pm 5V$  TO  $\pm 15V$
- LOW POWER CONSUMPTION : 50mW AT  $\pm 15V$
- CONTINUOUS SHORT-CIRCUIT PROTECTION
- OPERATION AS A COMPARATOR WITH DIFFERENTIAL INPUTS AS HIGH AS  $\pm 30V$
- NO LATCH-UP WHEN COMMON-MODE RANGE IS EXCEEDED
- SAME PIN CONFIGURATION AS THE LM101A

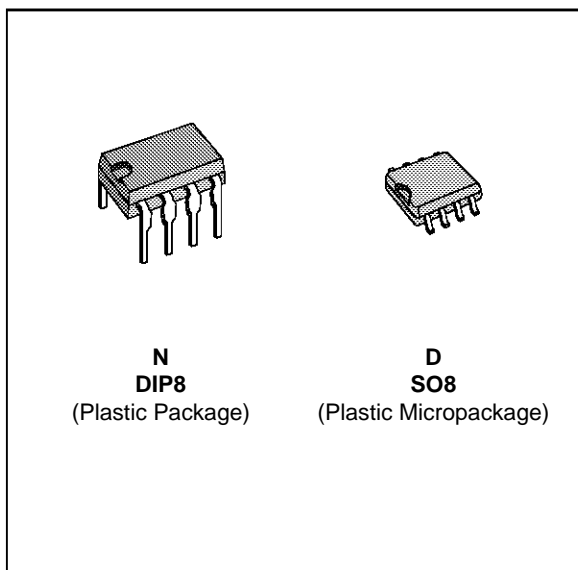

### ORDER CODES

Part Number	Temperature Range	Package	
		N	D
UA748C	0°C, +70°C	•	•
UA748I	-40°C, +105°C	•	•
UA748M	-55°C, +125°C	•	•

**Example :** UA748CN

748-01.TBL

### DESCRIPTION

The UA748 is a general-purpose operational amplifier built on a single silicon chip. The resulting close match and tight thermal coupling gives low offsets and temperature drift as well as fast recovery from thermal transients.

- Short-circuit protection
- Offset voltage null capability
- Large common-mode and differential voltage ranges
- Low power consumption
- No latch-up

The unity-gain compensation specified makes the circuit stable for all feedback configurations, even with capacitive loads. However, it is possible to optimize compensation for best high frequency performance at any gain. The low power dissipation permits high voltage operation and simplifies packaging in full-temperature range systems.

### PIN CONNECTIONS (top view)

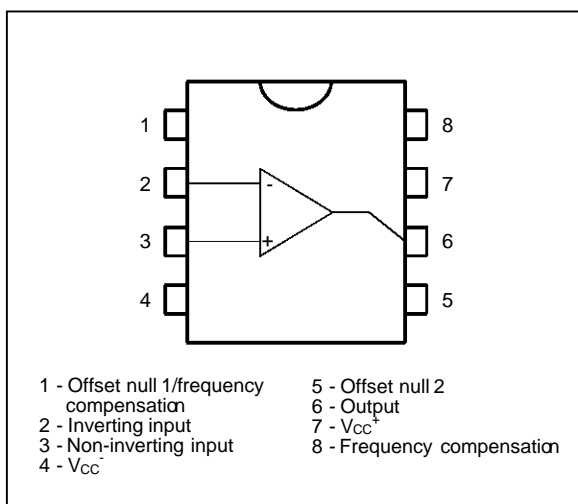

**SCHEMATIC DIAGRAM**

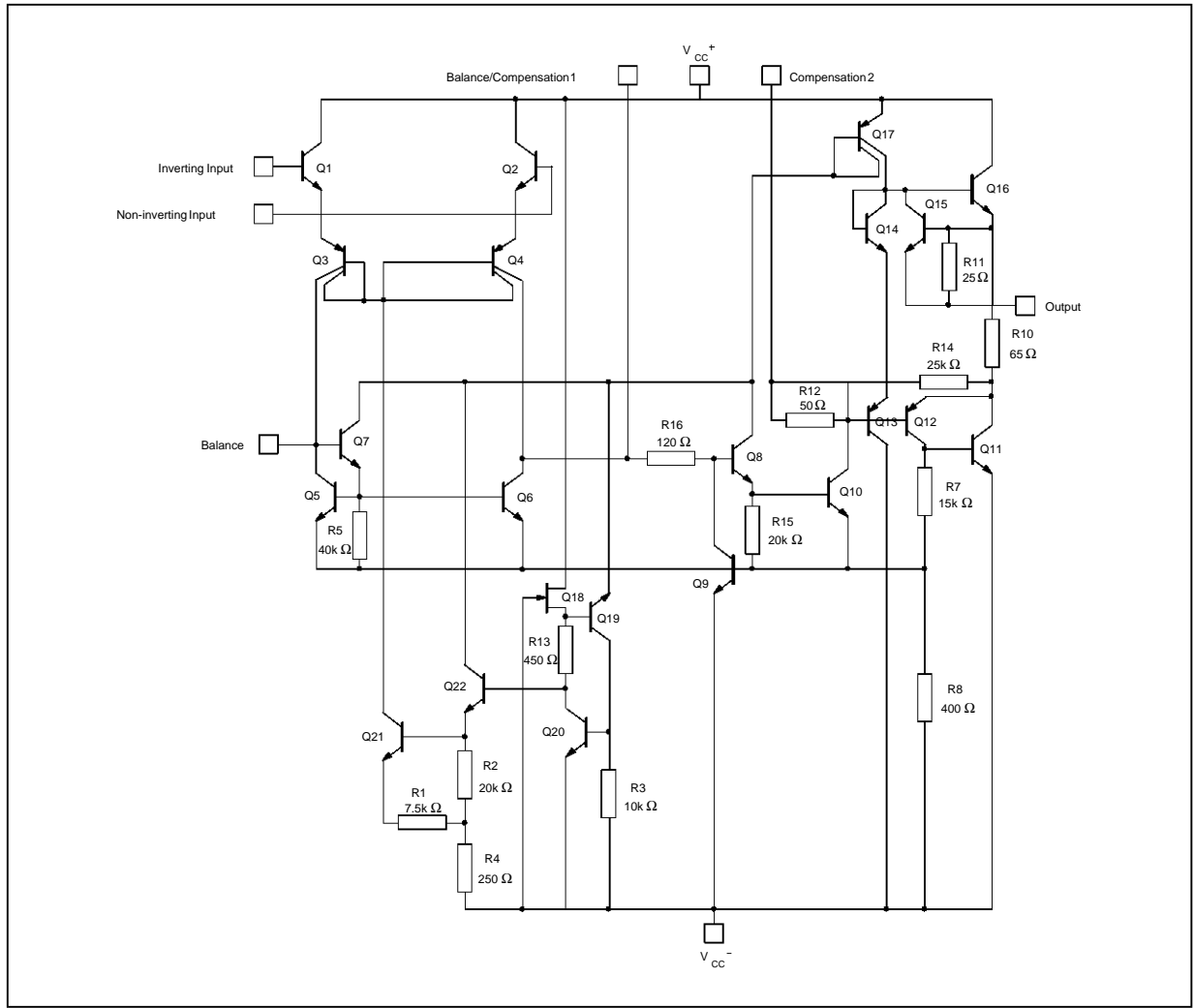

748-03.EPS

**ABSOLUTE MAXIMUM RATINGS**

Symbol	Parameter	Value			Unit
		UA748M	UA748I	UA748C	
V <sub>CC</sub>	Supply Voltage	±22	±22	±22	V
V <sub>i</sub>	Input Voltage	±15	±15	±15	V
V <sub>id</sub>	Differential Input Voltage	±30	±30	±30	V
P <sub>tot</sub>	Power Dissipation	500	500	500	mW
	Output Short-circuit Duration	Infinite			
T <sub>oper</sub>	Operating Free Air Temperature Range	-55 to +125	-40 to +105	0 to +70	°C
T <sub>stg</sub>	Storage Temperature Range	-65 to +150	-65 to +150	-65 to +150	°C

748-02.TBL

**ELECTRICAL CHARACTERISTICS**

$\pm 5V \leq V_{CC} \leq \pm 20V$ ,  $C_1 = 30pF$ ,  $T_{amb} = 25^\circ C$  (unless otherwise specified)

Symbol	Parameter	UA748-M-I			UA748C			Unit
		Min.	Typ.	Max.	Min.	Typ.	Max.	
$V_{io}$	Input Offset Voltage ( $R_s \leq 10k\Omega$ ) $T_{amb} = 25^\circ C$ $T_{min.} \leq T_{amb} \leq T_{max.}$		0.2	2 3		2	7.5 10	mV
$I_{ib}$	Input Bias Current $T_{amb} = 25^\circ C$ $T_{min.} \leq T_{amb} \leq T_{max.}$		1.5	10 20		2	50 70	nA
$I_{io}$	Input Offset Current $T_{amb} = 25^\circ C$ $T_{min.} \leq T_{amb} \leq T_{max.}$		25	75 10		70	250 300	nA
$A_{vd}$	Large Signal Voltage Gain ( $V_{CC} = \pm 15V$ , $V_o = \pm 10V$ , $R_L = 2k\Omega$ ) $T_{amb} = 25^\circ C$ $T_{min.} \leq T_{amb} \leq T_{max.}$	50 25	100		25 15	10		V/mV
SVR	Supply Voltage Rejection Ratio ( $R_s \leq 10k\Omega$ ) $T_{amb} = 25^\circ C$ $T_{min.} \leq T_{amb} \leq T_{max.}$	80 80	96		70 70	96		dB
$I_{CC}$	Supply Current, no load $T_{amb} = 25^\circ C$ $T_{min.} \leq T_{amb} \leq T_{max.}$		1.8	3 3		1.8	3 3	mA
$V_{icm}$	Input Common Mode Voltage Range ( $V_{CC} = \pm 20V$ ) $T_{amb} = 25^\circ C$ $T_{min.} \leq T_{amb} \leq T_{max.}$	$\pm 15$ $\pm 15$			$\pm 15$ $\pm 15$			V
CMR	Common Mode Rejection Ratio ( $R_s \leq 10k\Omega$ ) $T_{amb} = 25^\circ C$ $T_{min.} \leq T_{amb} \leq T_{max.}$	80 80	96		70 70	96		dB
$I_{os}$	Output Short-circuit Current ( $V_{CC} = \pm 15V$ )	10	30	50	10	30	50	mA
$\pm V_{OPP}$	Output Voltage Swing ( $V_{CC} = \pm 15V$ ) $T_{amb} = 25^\circ C$ $T_{min.} \leq T_{amb} \leq T_{max.}$	12 10 12 10	14 13		12 10 12 10	14 13		V
SR	Slew Rate ( $V_{CC} = \pm 15V$ , $V_i = \pm 10V$ , $R_L = 2k\Omega$ , $C_L = 100pF$ , $T_{amb} = 25^\circ C$ , unity gain)	0.25	0.5		0.25	0.5		V/ $\mu s$
$t_r$	Rise Time ( $V_{CC} = \pm 15V$ , $V_i = \pm 20mV$ , $R_L = 2k\Omega$ , $C_L = 100pF$ , $T_{amb} = 25^\circ C$ , unity gain)		0.3			0.3		$\mu s$
$K_{OV}$	Overshoot ( $V_{CC} = \pm 15V$ , $V_i = 20mV$ , $R_L = 2k\Omega$ , $C_L = 100pF$ , $T_{amb} = 25^\circ C$ , unity gain)		5			5		%
$Z_i$	Input Impedance ( $V_{CC} = \pm 15V$ )	1.5	4		1.5	4		M $\Omega$
$R_o$	Output Resistance ( $V_{CC} = \pm 15V$ )		75			75		$\Omega$
GBP	Gain Bandwidth Product ( $V_{CC} = \pm 15V$ , $V_i = 10mV$ , $R_L = 2k\Omega$ , $C_L = 100pF$ , $f = 100kHz$ )	0.5	1		0.5	1		MHz
THD	Total Harmonic Distortion ( $V_{CC} = \pm 15V$ , $f = 1kHz$ , $A_V = 20dB$ , $R_L = 2k\Omega$ , $V_o = 2V_{PP}$ , $C_L = 100pF$ )		0.015			0.015		%
$e_n$	Equivalent Input Noise Voltage ( $V_{CC} = \pm 15V$ , $f = 1kHz$ , $R_s = 100\Omega$ )		25			25		$\frac{nV}{\sqrt{Hz}}$
$DV_{io}$	Input Offset Current Drift $25^\circ C \leq T_{amb} \leq T_{max}$ $T_{min.} \leq T_{amb} \leq 25^\circ C$		10 20	100 200		10 20	300 600	$pA/^\circ C$
$DI_{io}$	Input Offset Voltage Drift $T_{min.} \leq T_{amb} \leq T_{max.}$		3	15		6	30	$\mu V/^\circ C$

748-03.TBL

**CURRENT LIMITING**

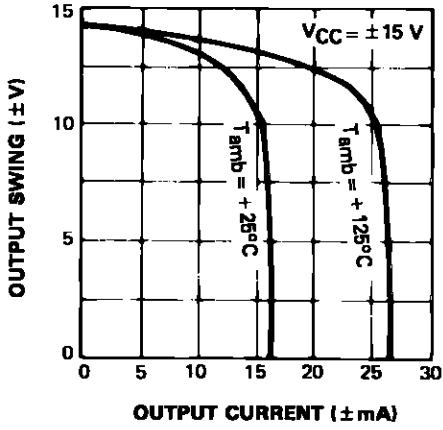

748-04.EPS

**INPUT CURRENT**

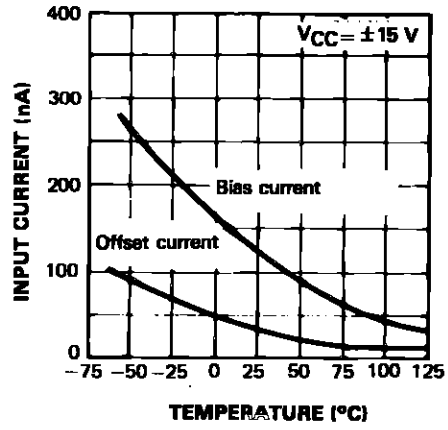

748-05.EPS

**OPEN LOOP FREQUENCY RESPONSE**

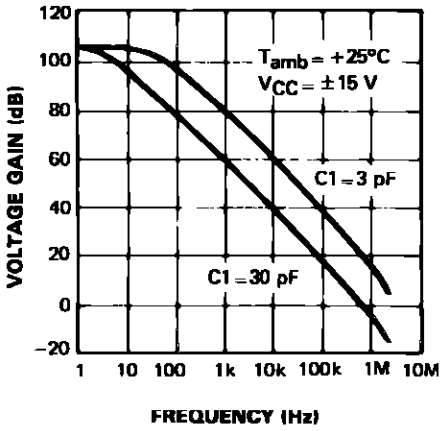

748-06.EPS

**LARGE SIGNAL FREQUENCY RESPONSE**

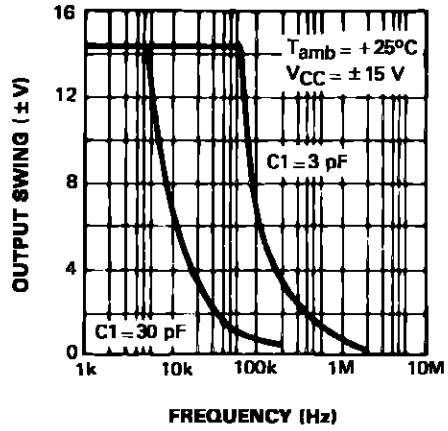

748-07.EPS

**FREQUENCY COMPENSATION**

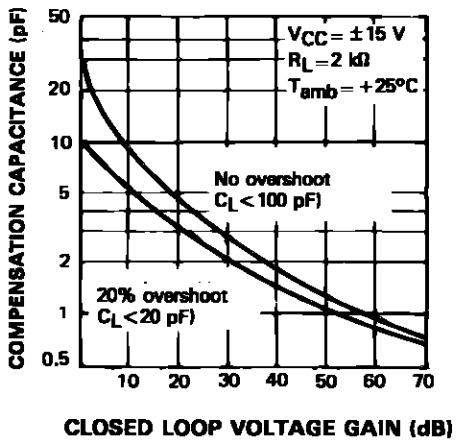

748-08.EPS

**VOLTAGE FOLLOWER PULSE RESPONSE**

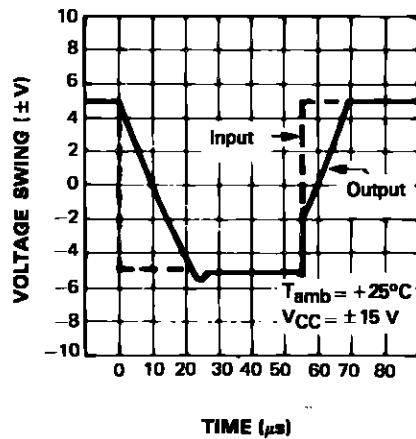

748-09.EPS

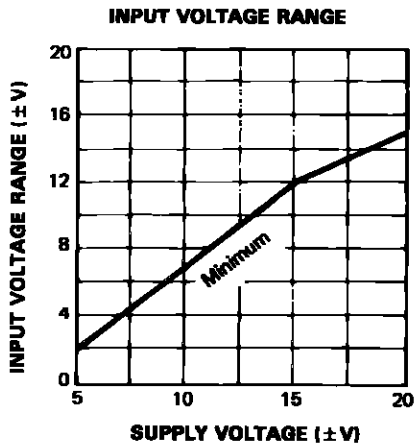

748-10.EPS

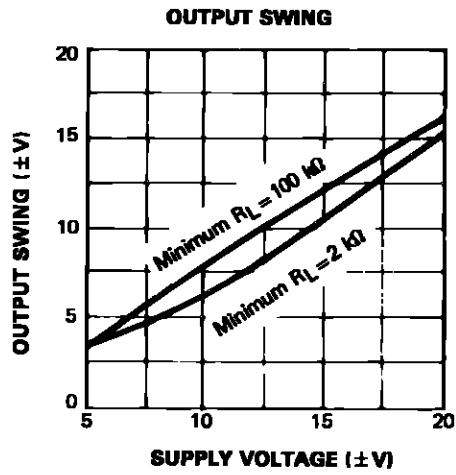

748-11.EPS

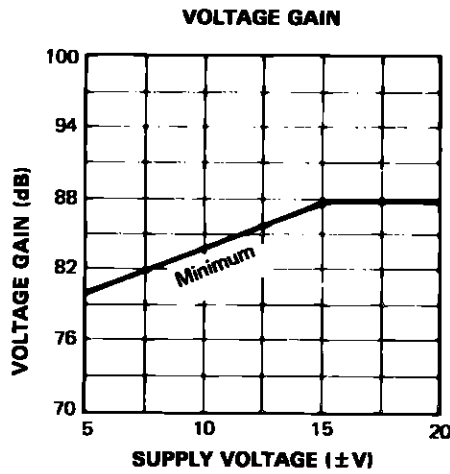

748-12.EPS

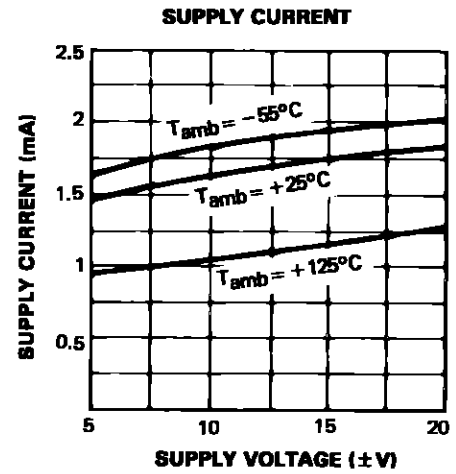

748-13.EPS

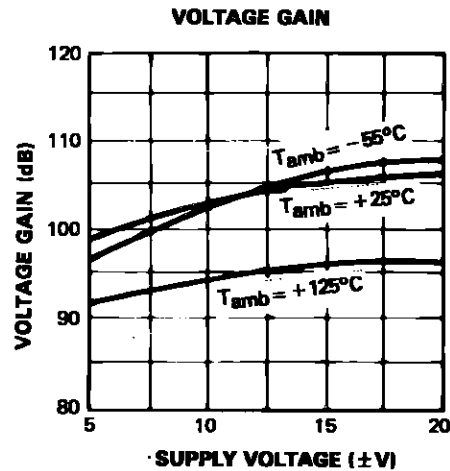

748-14.EPS

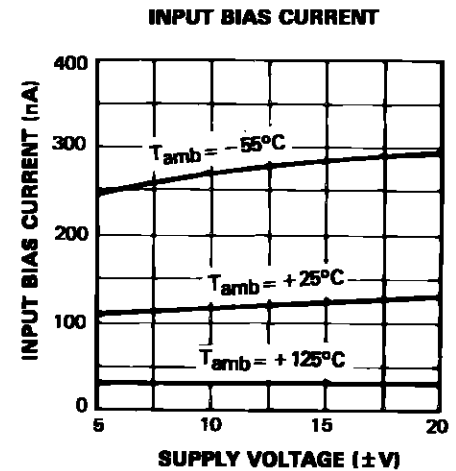

748-15.EPS

TYPICAL APPLICATIONS

PRACTICAL DIFFERENTIATOR

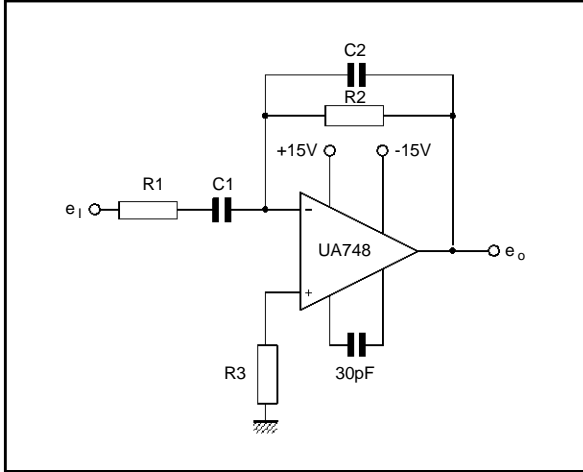

748-16.EPS

SINGLE SUPPLY OPERATION

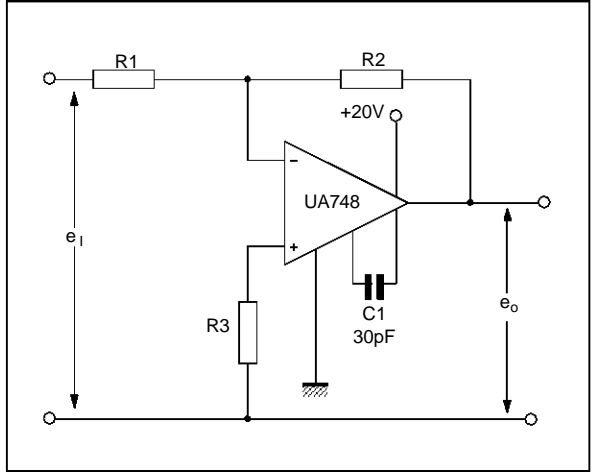

748-17.EPS

PULSE WIDTH MODULATOR

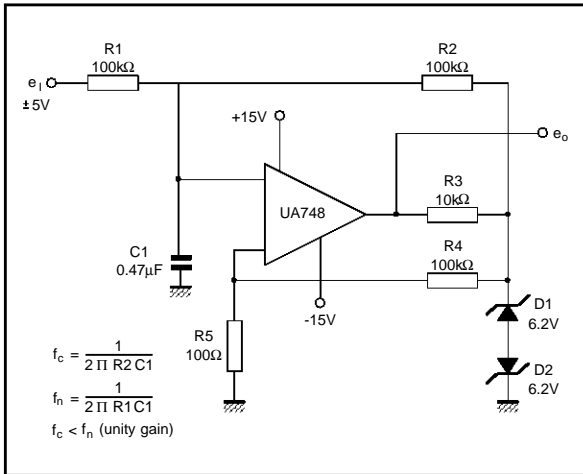

748-18.EPS

FEED-FORWARD COMPENSATION

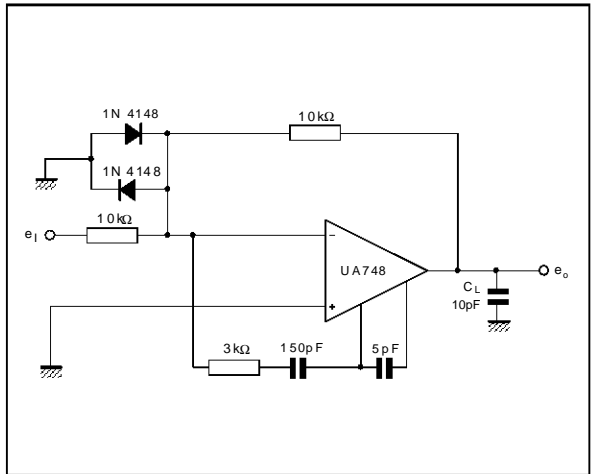

748-19.EPS

LARGE SIGNAL FEED-FORWARD TRANSIENT RESPONSE

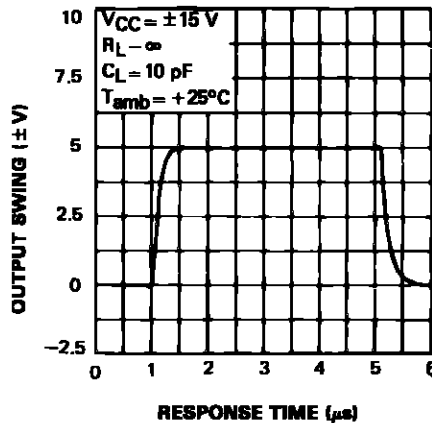

748-20.EPS

**PACKAGE MECHANICAL DATA**  
8 PINS - PLASTIC DIP OR CERDIP

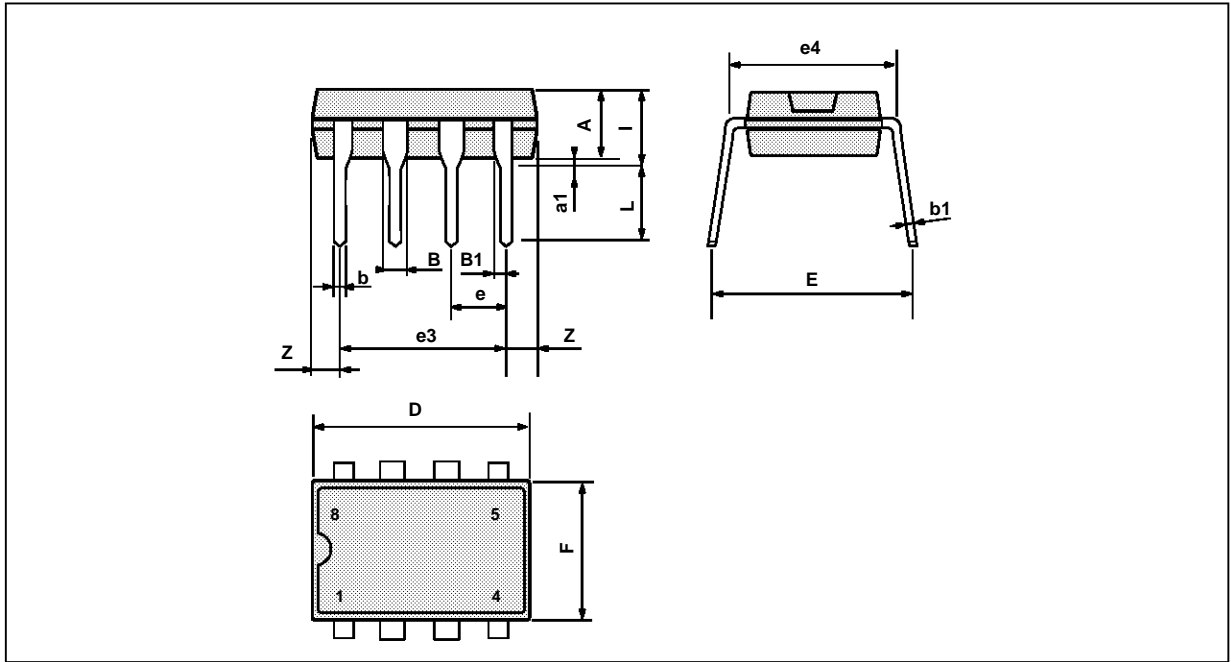

PM-DIP8.EPS

Dimensions	Millimeters			Inches		
	Min.	Typ.	Max.	Min.	Typ.	Max.
A		3.32			0.131	
a1	0.51			0.020		
B	1.15		1.65	0.045		0.065
b	0.356		0.55	0.014		0.022
b1	0.204		0.304	0.008		0.012
D			10.92			0.430
E	7.95		9.75	0.313		0.384
e		2.54			0.100	
e3		7.62			0.300	
e4		7.62			0.300	
F			6.6			0.260
i			5.08			0.200
L	3.18		3.81	0.125		0.150
Z			1.52			0.060

DIP8.TBL

**PACKAGE MECHANICAL DATA**  
8 PINS - PLASTIC MICROPACKAGE (SO)

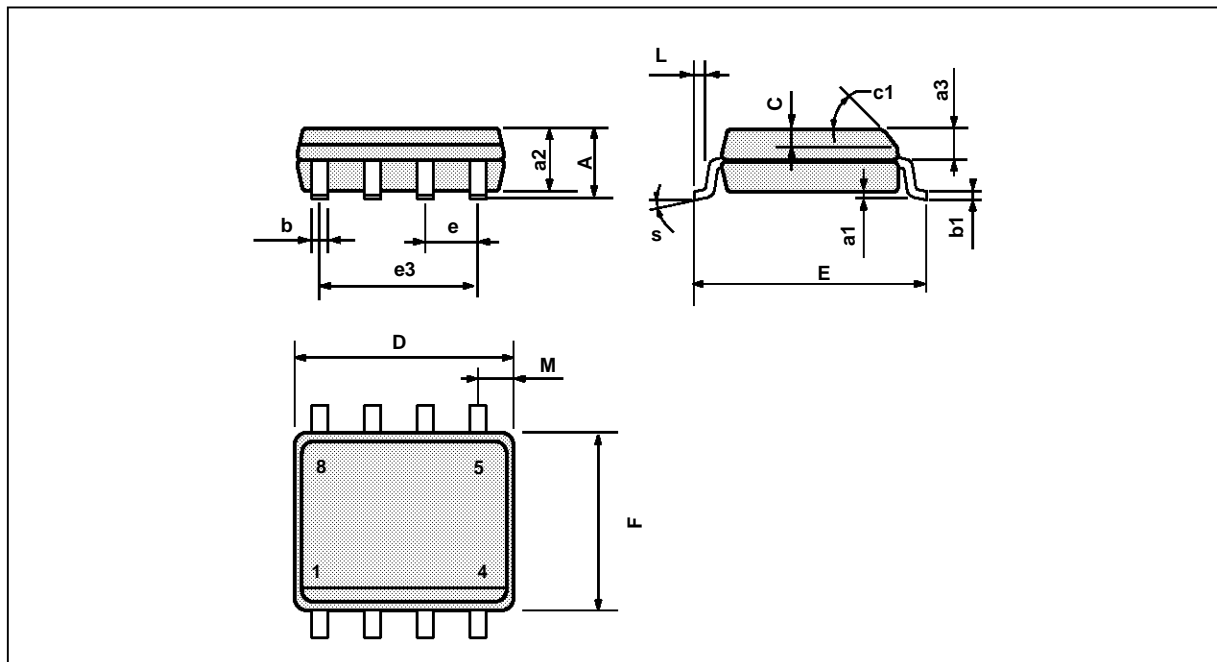

PM-S06.EPS

Dimensions	Millimeters			Inches		
	Min.	Typ.	Max.	Min.	Typ.	Max.
A			1.75			0.069
a1	0.1		0.25	0.004		0.010
a2			1.65			0.065
a3	0.65		0.85	0.026		0.033
b	0.35		0.48	0.014		0.019
b1	0.19		0.25	0.007		0.010
C	0.25		0.5	0.010		0.020
c1	45° (typ.)					
D	4.8		5.0	0.189		0.197
E	5.8		6.2	0.228		0.244
e		1.27			0.050	
e3		3.81			0.150	
F	3.8		4.0	0.150		0.157
L	0.4		1.27	0.016		0.050
M			0.6			0.024
S	8° (max.)					

SO8.TBL

Information furnished is believed to be accurate and reliable. However, SGS-THOMSON Microelectronics assumes no responsibility for the consequences of use of such information nor for any infringement of patents or other rights of third parties which may result from its use. No licence is granted by implication or otherwise under any patent or patent rights of SGS-THOMSON Microelectronics. Specifications mentioned in this publication are subject to change without notice. This publication supersedes and replaces all information previously supplied. SGS-THOMSON Microelectronics products are not authorized for use as critical components in life support devices or systems without express written approval of SGS-THOMSON Microelectronics.

© 1995 SGS-THOMSON Microelectronics - All Rights Reserved

SGS-THOMSON Microelectronics GROUP OF COMPANIES

Australia - Brazil - France - Germany - Hong Kong - Italy - Japan - Korea - Malaysia - Malta - Morocco - The Netherlands  
Singapore - Spain - Sweden - Switzerland - Taiwan - Thailand - United Kingdom - U.S.A.

ORDER CODE :