

# AN7161NFP

## BTL High Audio Power Amplifier

### ■ Description

The AN7161N is a monolithic integrated circuit designed for BTL audio high power amplifier with built-in headphone amplifier. It can be widely applicable to Hi Fi, car stereo and TV sound multiplex output.

### ■ Features

- Low quiescent current, low distortion, low noise, high output power
- Wide supply voltage range:  $V_{CC} = 6V \sim 26V$
- Incorporating headphone amplifier circuit
- Built-in muting circuit
- Incorporating protection circuits
- 12-Lead single-in-line package
- Fewer external components
- Low shock noise from power ON/OFF operation

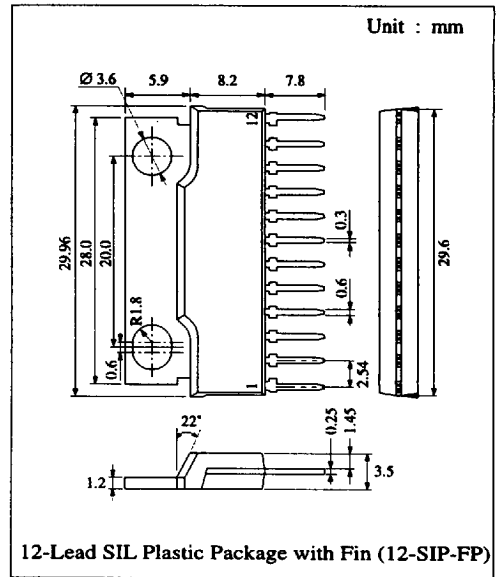

### ■ Block Diagram

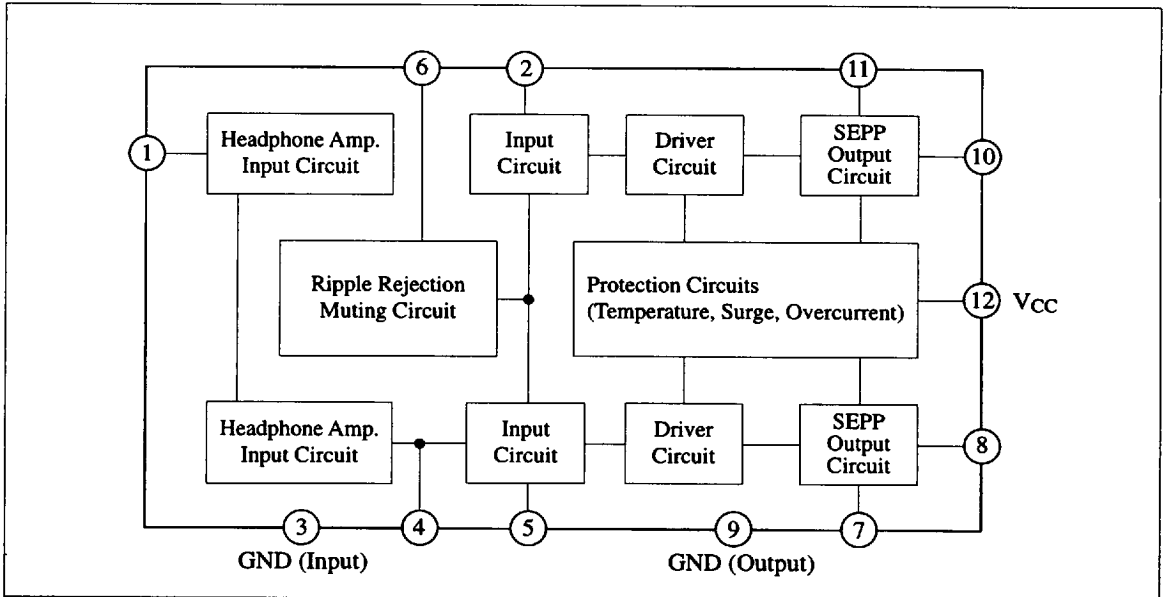

### ■ Absolute Maximum Ratings (Ta=25°C)

Item	Symbol	Rating	Unit
Supply Voltage	V <sub>CC</sub>	26	V
Supply Current	I <sub>CC</sub>	4	A
Power Dissipation	P <sub>D</sub>	41.7	W
Surge Supply Voltage	V <sub>CC(surge)</sub>	50	V
Operating Ambient Temperature	T <sub>opr</sub>	-30 ~ +75	°C
Storage Temperature	T <sub>stg</sub>	-55 ~ +150	°C

Operating Supply Voltage Range: V<sub>CC</sub> = 6.0V ~ 26.0V

### ■ Electrical Characteristics (V<sub>CC</sub>=15V, R<sub>L</sub>=4Ω, f=1kHz, Ta=25°C)

Item	Symbol	Condition	min.	typ.	max.	Unit
Quiescent Current	I <sub>CQ</sub>	V <sub>in</sub> = 0mV		45	76	mA

#### Power Amplifier

Output Noise Voltage	V <sub>no</sub>	R <sub>g</sub> = 10kΩ, f = 15Hz~30kHz, 12dB/OCT		0.6	1.0	mV
Voltage Gain	G <sub>V</sub>	V <sub>in</sub> = 5mV	48.5	50.5	52.5	dB
Total Harmonic Distortion	THD	V <sub>in</sub> = 5mV		0.15	0.5	%
Maximum Output Power	P <sub>O</sub>	THD = 10%	20	23		W
Output Offset Voltage	V <sub>O(offset)</sub>	R <sub>g</sub> = 0Ω			150	mV

#### Headphone Amp.

Output Noise Voltage	V <sub>no-H</sub>	R <sub>g</sub> = 10kΩ, f = 15Hz~30kHz, 12dB/OCT		0.1	0.7	mV
Voltage Gain	G <sub>V-H</sub>	V <sub>in</sub> = 10mV	17.5	19.5	21.5	dB
Maximum Output Voltage	P <sub>O-H</sub>	THD = 1%	10			mW

Note: For Power Amplifier, R<sub>L</sub> = 4Ω

For Headphone Amp., R<sub>L</sub> = 33Ω

### ■ Pin

Pin No	Pin Name	Pin No	Pin Name
1	Output (Headphone)	7	Bootstrap Ch.1
2	N.F.B. Ch.2	8	Output Ch.1
3	GND (Input)	9	GND (Output)
4	Input	10	Output Ch.2
5	N.F.B Ch.1	11	Bootstrap Ch.2
6	Ripple Filter	12	V <sub>CC</sub>

■ Application Circuit

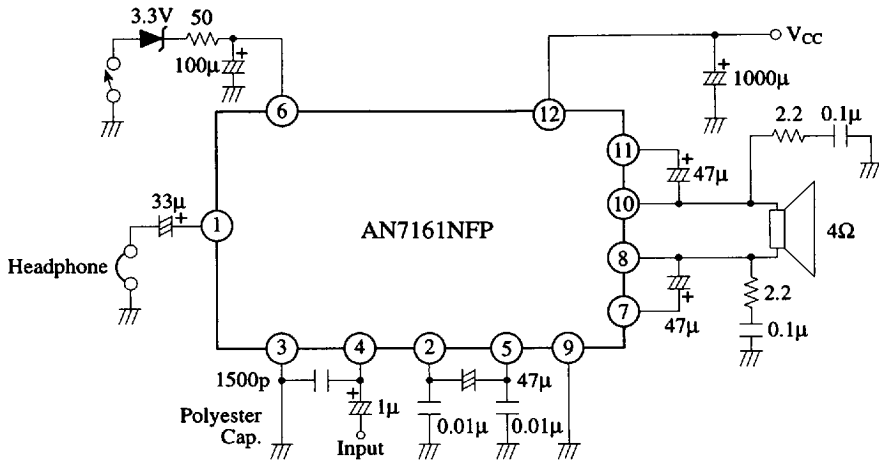

■ Characteristics Curve

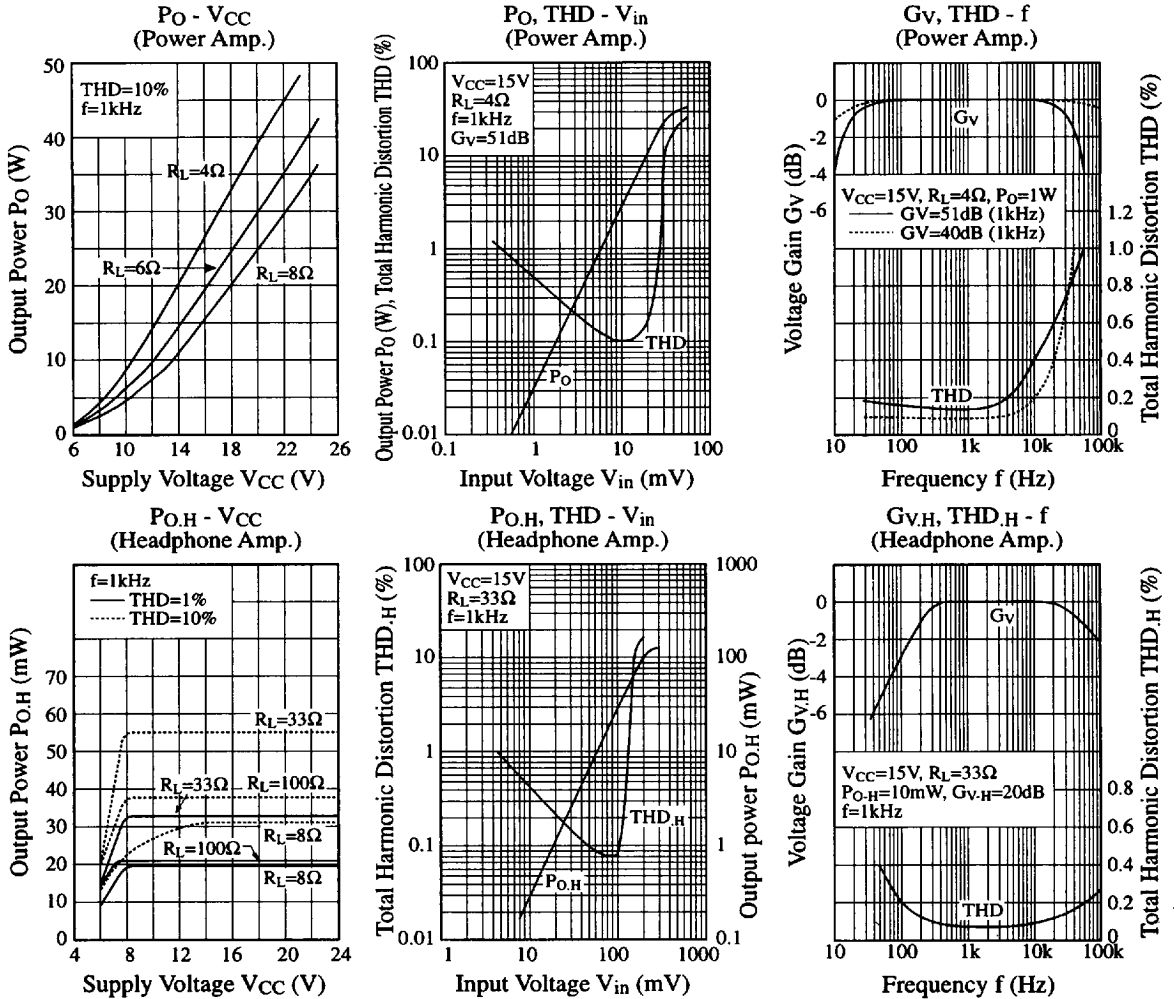

## ■ Characteristics Curve (Continue)

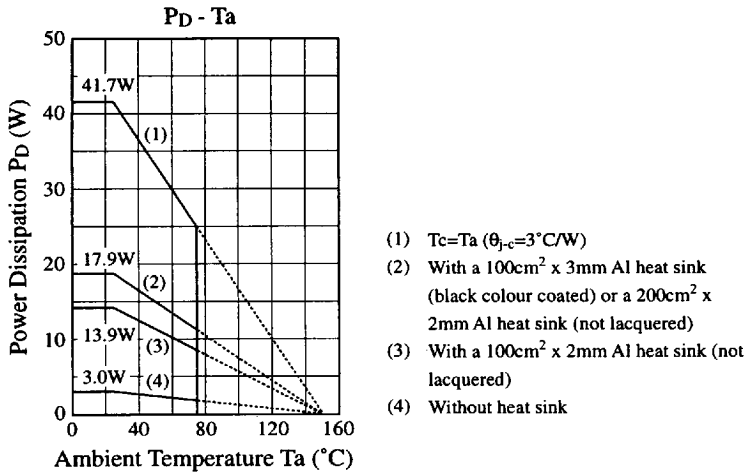

## ■ Printed Circuit Board Layout (Scale: 1:1)

