

D5S9M

Forward Voltage

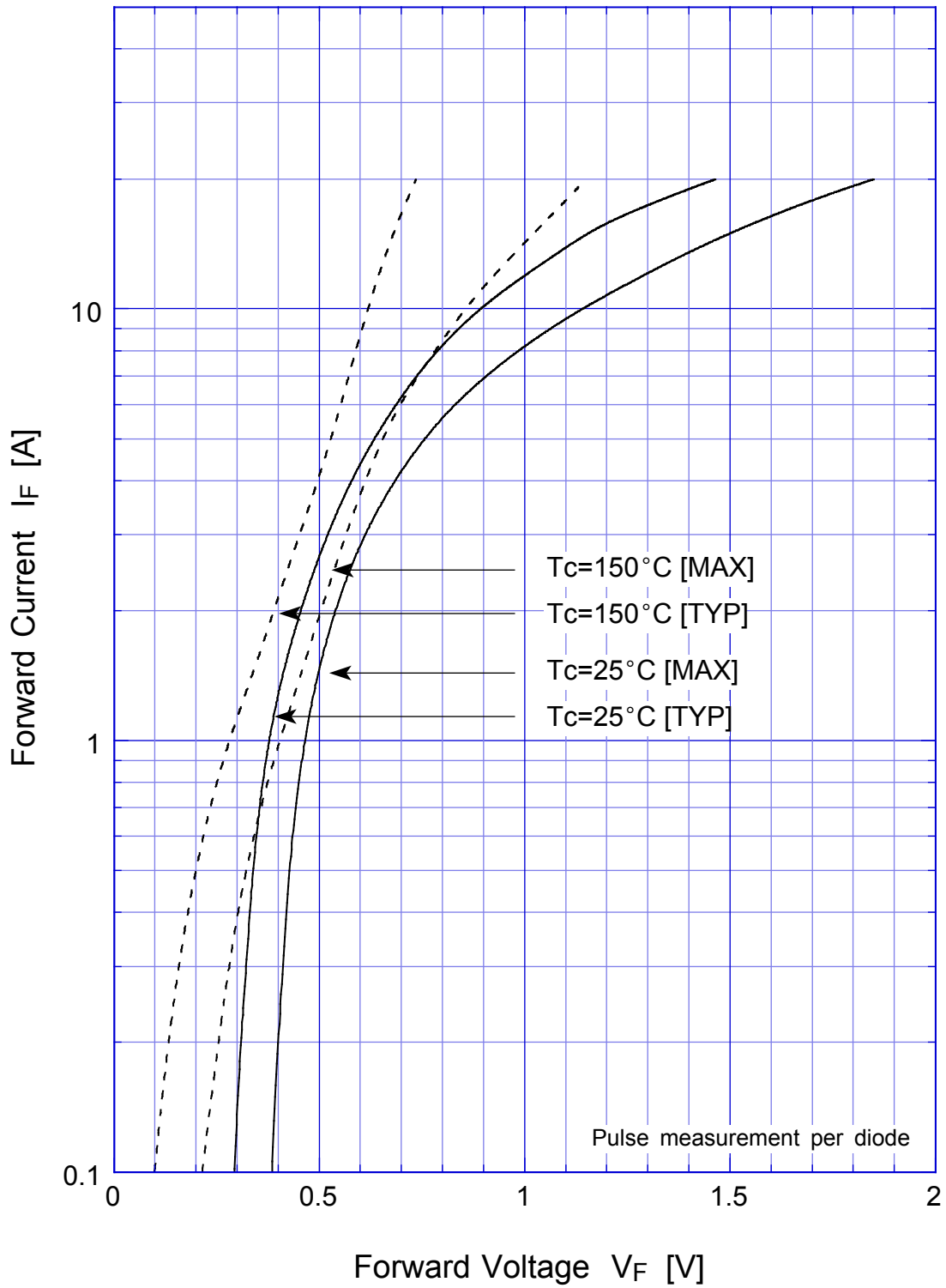

D5S9M

Junction Capacitance

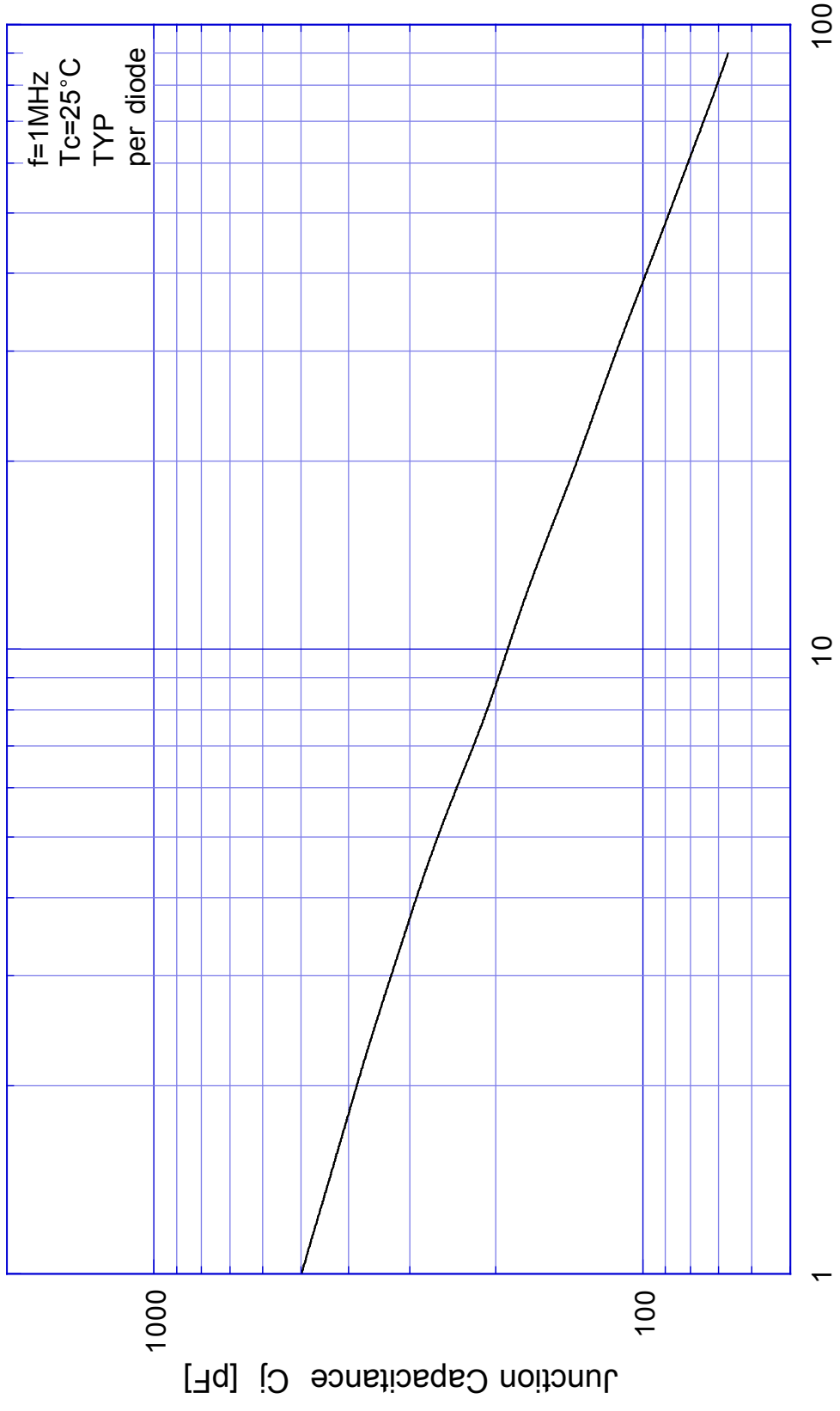

D5S9M

Reverse Current

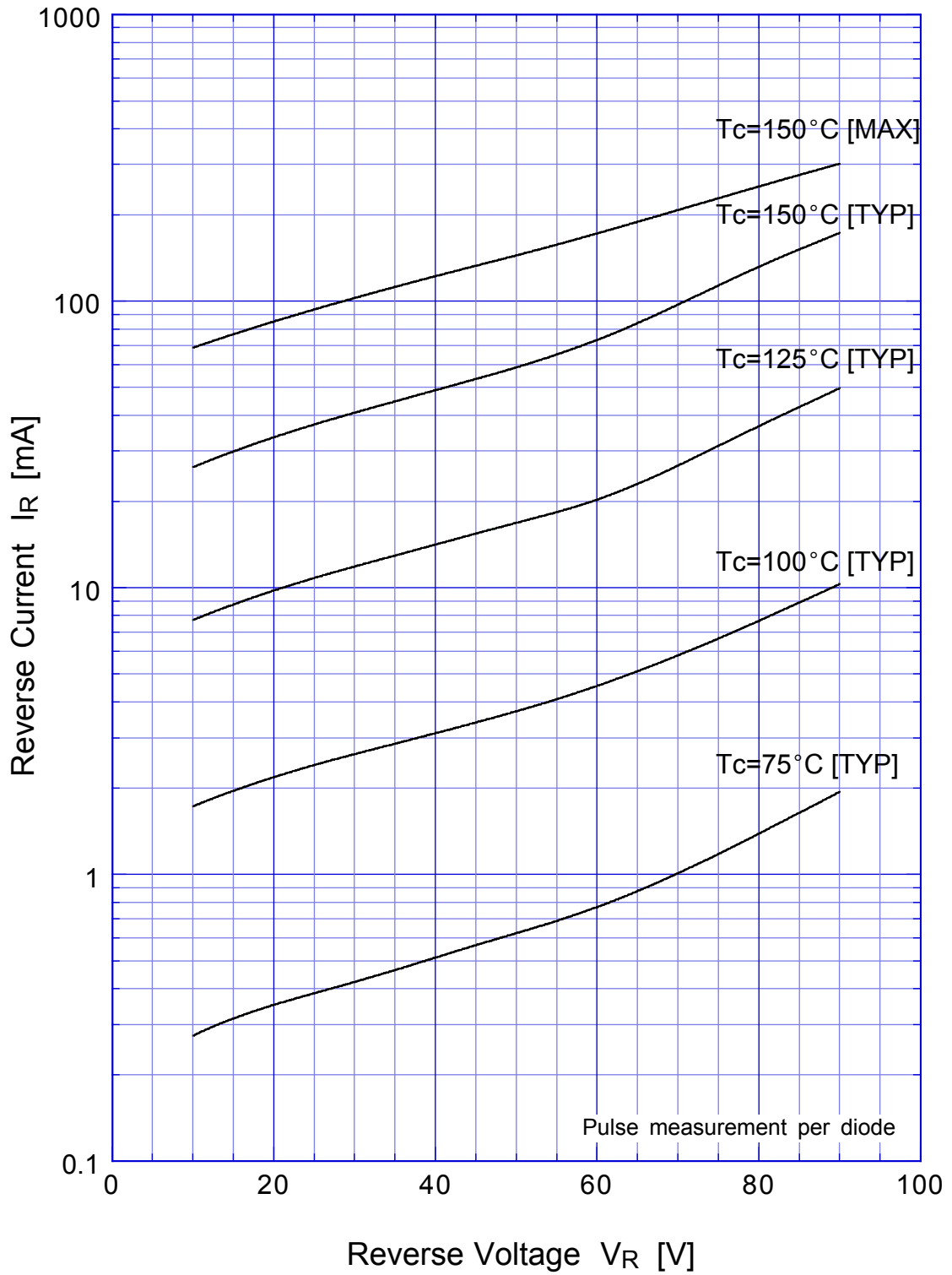

D5S9M

Reverse Power Dissipation

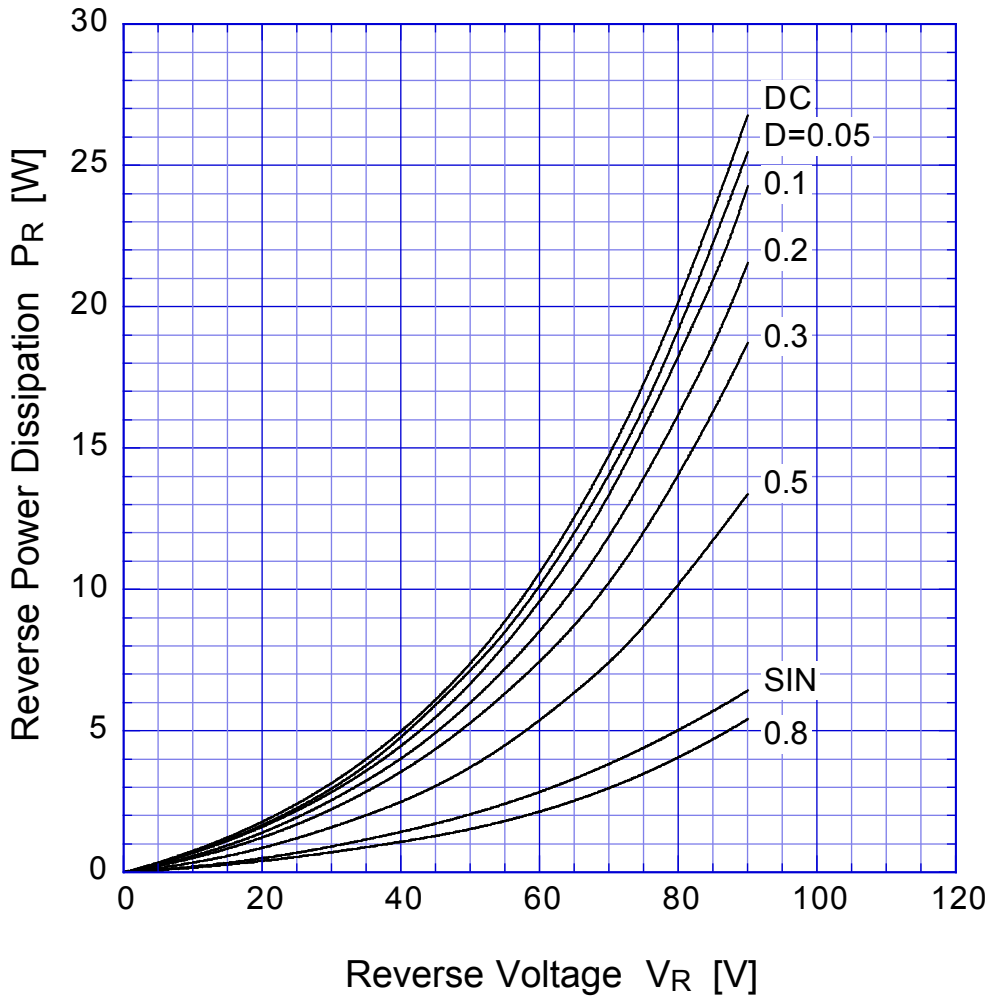

$T_j = 150^\circ\text{C}$

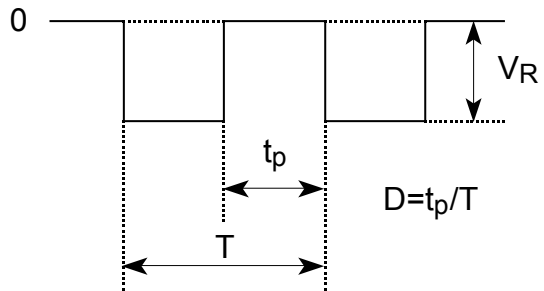

D5S9M

Forward Power Dissipation

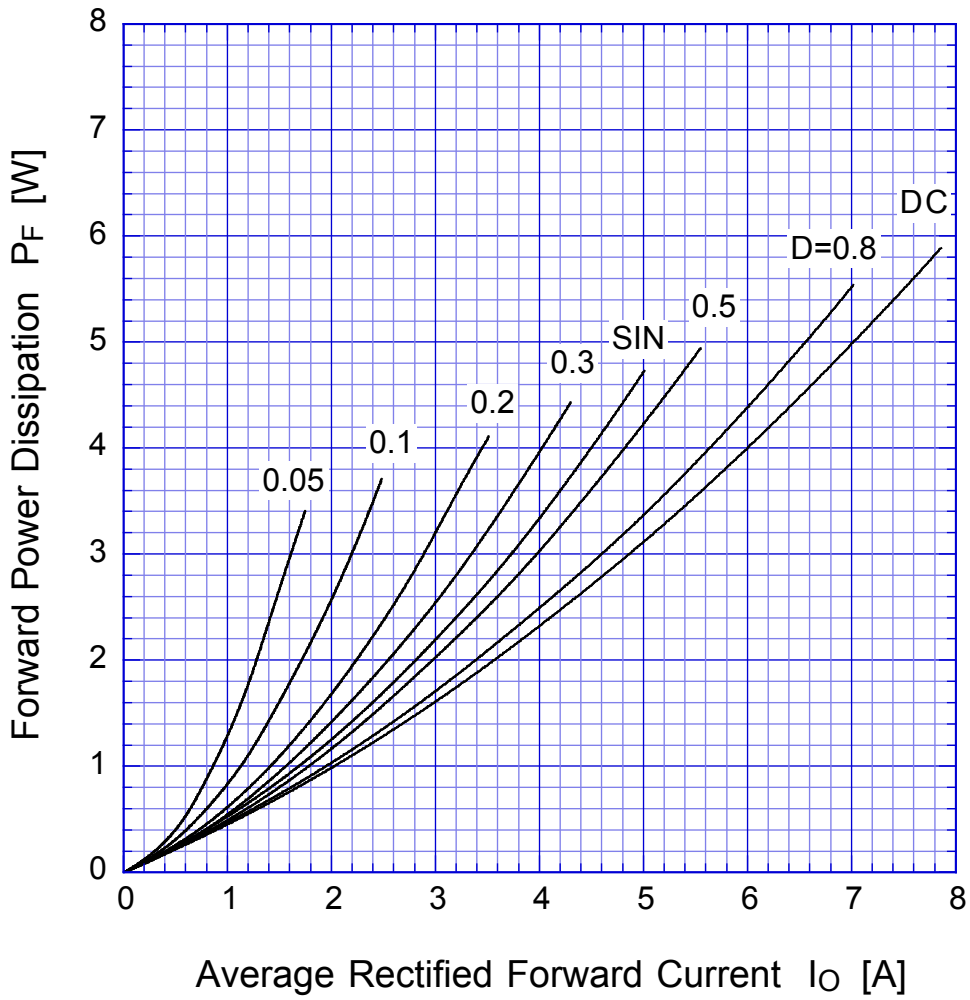

$T_j = 150^\circ\text{C}$

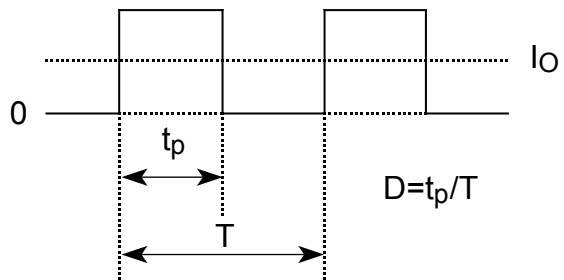

D5S9M

Derating Curve

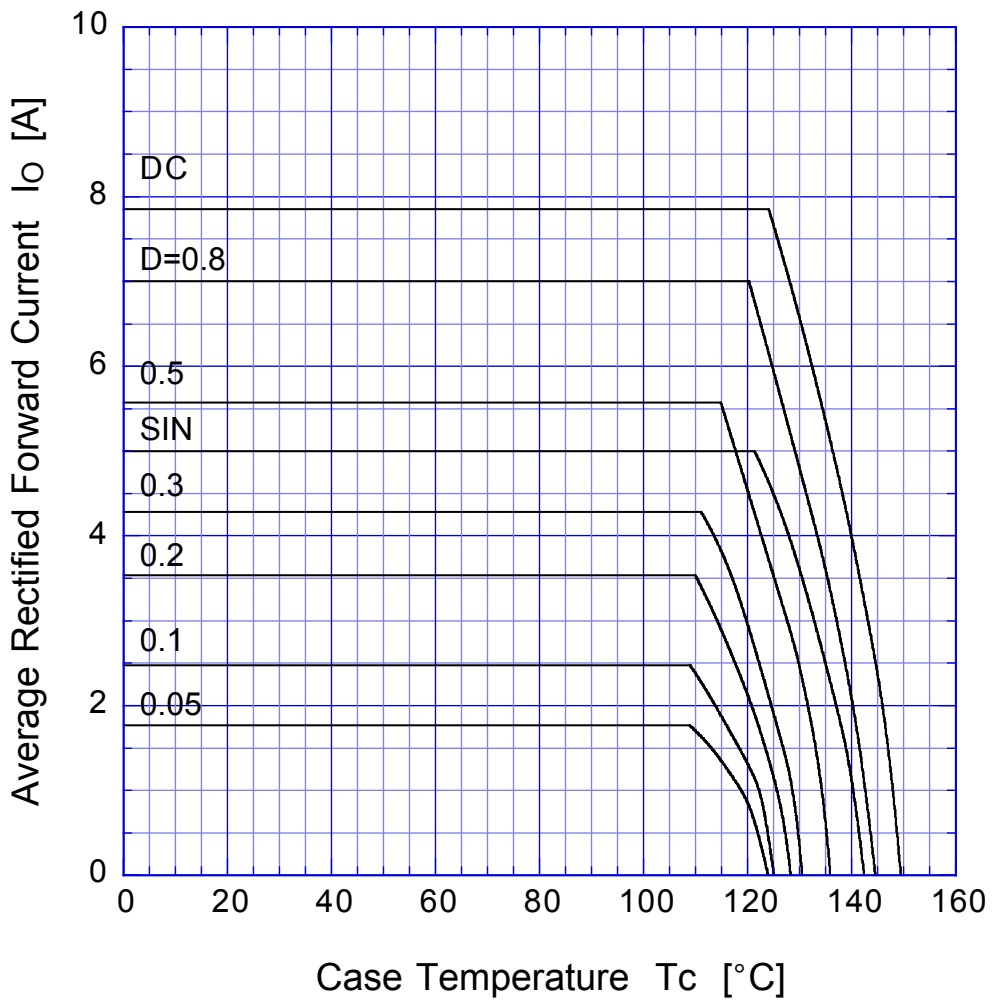

$V_R = 45V$



D5S9M

Derating Curve

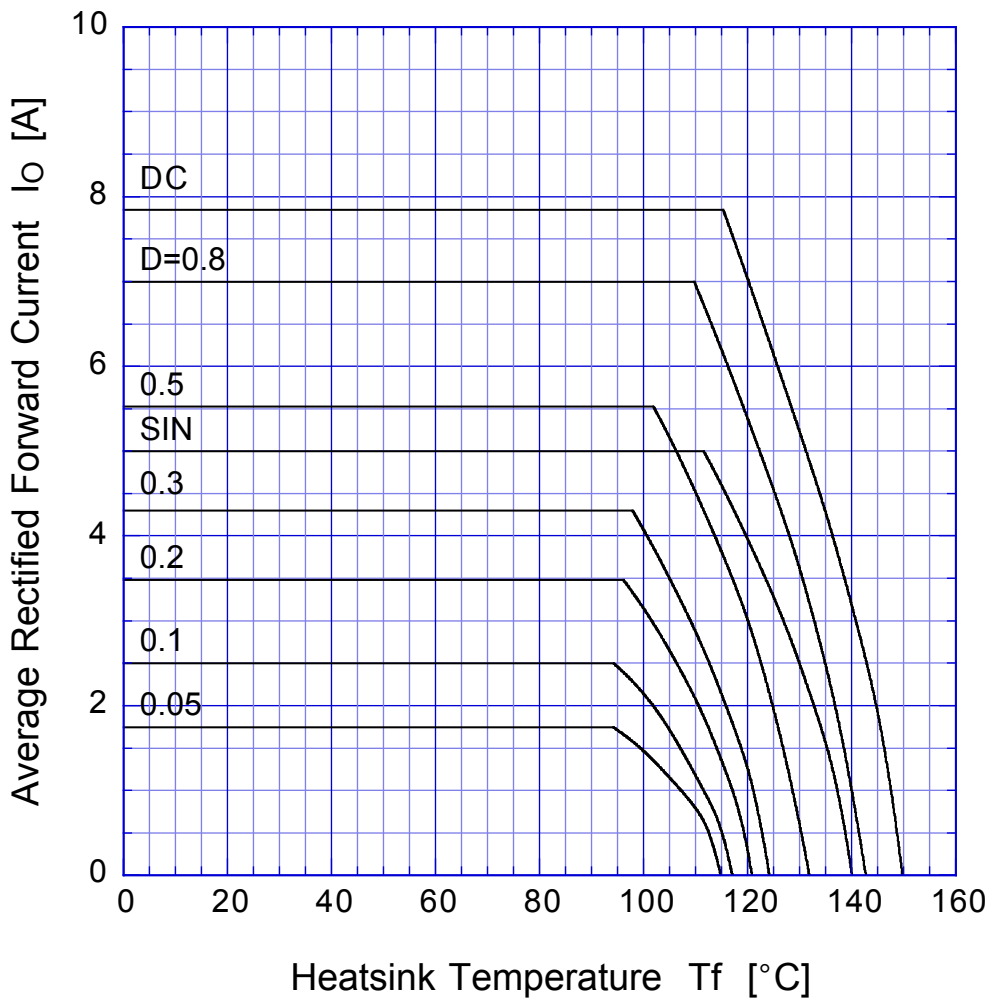

$V_R = 45V$

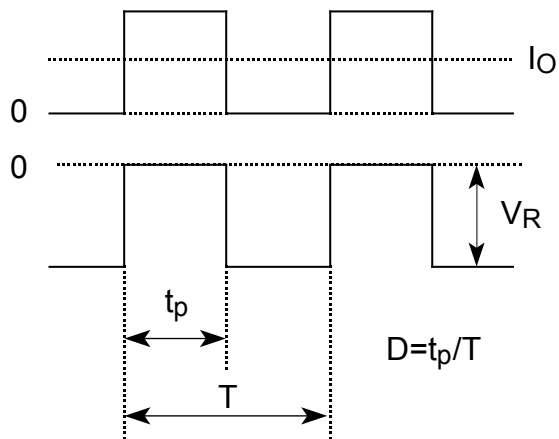

D5S9M

Peak Surge Forward Capability

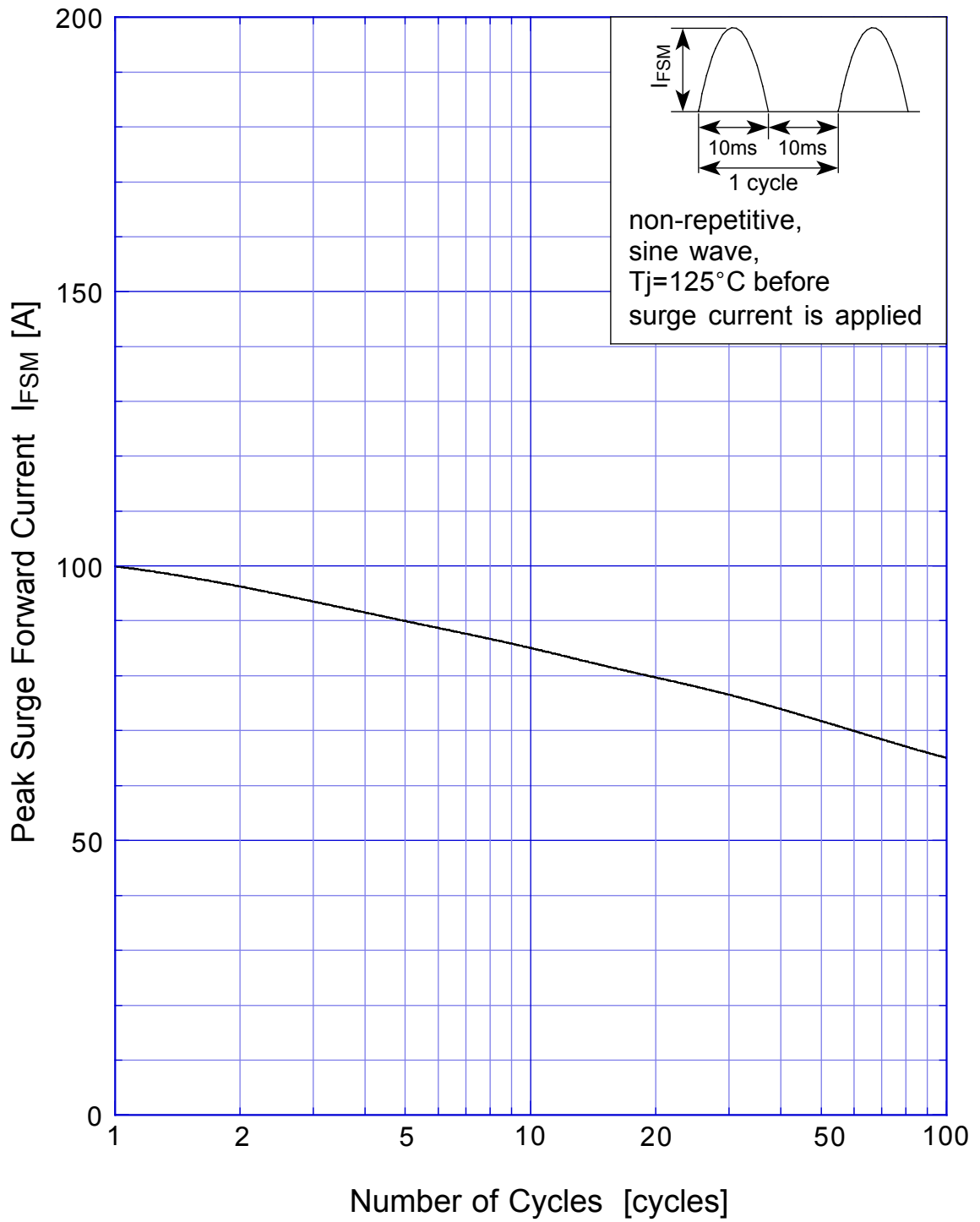

SBD Repetitive Surge Reverse Power Derating Curve

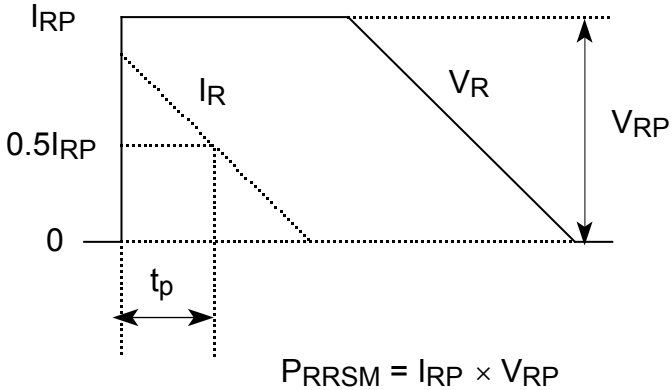

SBD

Repetitive Surge Reverse Power Capability

