

LM158/LM258/LM358/LM2904

Low Power Dual Operational Amplifiers

General Description

The LM158 series consists of two independent, high gain, internally frequency compensated operational amplifiers which were designed specifically to operate from a single power supply over a wide range of voltages. Operation from split power supplies is also possible and the low power supply current drain is independent of the magnitude of the power supply voltage.

Application areas include transducer amplifiers, dc gain blocks and all the conventional op amp circuits which now can be more easily implemented in single power supply systems. For example, the LM158 series can be directly operated off of the standard +5V power supply voltage which is used in digital systems and will easily provide the required interface electronics without requiring the additional $\pm 15V$ power supplies.

The LM358 is also available in a chip sized package (8-Bump micro SMD) using National's micro SMD package technology.

Unique Characteristics

- In the linear mode the input common-mode voltage range includes ground and the output voltage can also swing to ground, even though operated from only a single power supply voltage.
- The unity gain cross frequency is temperature compensated.
- The input bias current is also temperature compensated.

Advantages

- Two internally compensated op amps
- Eliminates need for dual supplies
- Allows direct sensing near GND and V_{OUT} also goes to GND
- Compatible with all forms of logic
- Power drain suitable for battery operation
- Pin-out same as LM1558/LM1458 dual op amp

Features

- Available in 8-Bump micro SMD chip sized package, (See AN-1112)
- Internally frequency compensated for unity gain
- Large dc voltage gain: 100 dB
- Wide bandwidth (unity gain): 1 MHz (temperature compensated)
- Wide power supply range:
 - Single supply: 3V to 32V
 - or dual supplies: $\pm 1.5V$ to $\pm 16V$
- Very low supply current drain (500 μA)—essentially independent of supply voltage
- Low input offset voltage: 2 mV
- Input common-mode voltage range includes ground
- Differential input voltage range equal to the power supply voltage
- Large output voltage swing: 0V to $V^+ - 1.5V$

Voltage Controlled Oscillator (VCO)

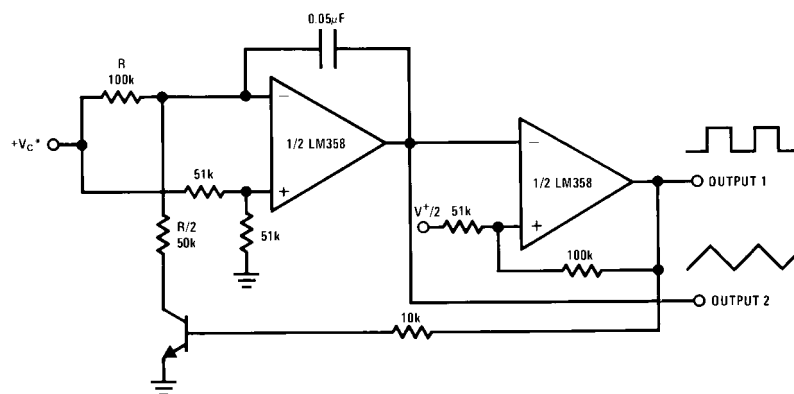

DS007787-23

Absolute Maximum Ratings (Note 9)

If Military/Aerospace specified devices are required, please contact the National Semiconductor Sales Office/Distributors for availability and specifications.

	LM158/LM258/LM358 LM158A/LM258A/LM358A	LM2904
Supply Voltage, V^+	32V	26V
Differential Input Voltage	32V	26V
Input Voltage	-0.3V to +32V	-0.3V to +26V
Power Dissipation (Note 1)		
Molded DIP	830 mW	830 mW
Metal Can	550 mW	
Small Outline Package (M)	530 mW	530 mW
micro SMD	435mW	
Output Short-Circuit to GND (One Amplifier) (Note 2) $V^+ \leq 15V$ and $T_A = 25^\circ C$	Continuous	Continuous
Input Current ($V_{IN} < -0.3V$) (Note 3)	50 mA	50 mA
Operating Temperature Range		
LM358	0°C to +70°C	-40°C to +85°C
LM258	-25°C to +85°C	
LM158	-55°C to +125°C	
Storage Temperature Range	-65°C to +150°C	-65°C to +150°C
Lead Temperature, DIP (Soldering, 10 seconds)	260°C	260°C
Lead Temperature, Metal Can (Soldering, 10 seconds)	300°C	300°C
Soldering Information		
Dual-In-Line Package		
Soldering (10 seconds)	260°C	260°C
Small Outline Package		
Vapor Phase (60 seconds)	215°C	215°C
Infrared (15 seconds)	220°C	220°C
See AN-450 "Surface Mounting Methods and Their Effect on Product Reliability" for other methods of soldering surface mount devices.		
ESD Tolerance (Note 10)	250V	250V

Electrical Characteristics

$V^+ = +5.0V$, unless otherwise stated

Parameter	Conditions	LM158A		LM358A		LM158/LM258		Units
		Min	Typ	Max	Min	Typ	Max	
Input Offset Voltage	(Note 5), $T_A = 25^\circ C$	1	2	2	3	2	5	mV
Input Bias Current	$I_{IN(+)}$ or $I_{IN(-)}$, $T_A = 25^\circ C$, $V_{CM} = 0V$, (Note 6)	20	50	45	100	45	150	nA
Input Offset Current	$I_{IN(+)} - I_{IN(-)}$, $V_{CM} = 0V$, $T_A = 25^\circ C$	2	10	5	30	3	30	nA
Input Common-Mode Voltage Range	$V^+ = 30V$, (Note 7) (LM2904, $V^+ = 26V$), $T_A = 25^\circ C$	0	$V^+ - 1.5$	0	$V^+ - 1.5$	0	$V^+ - 1.5$	V
Supply Current	Over Full Temperature Range $R_L = \infty$ on All Op Amps $V^+ = 30V$ (LM2904 $V^+ = 26V$) $V^+ = 5V$	1	2	1	2	1	2	mA
		0.5	1.2	0.5	1.2	0.5	1.2	mA

Electrical Characteristics

$V^+ = +5.0V$, unless otherwise stated

Parameter	Conditions	LM358			LM2904			Units
		Min	Typ	Max	Min	Typ	Max	
Input Offset Voltage	(Note 5), $T_A = 25^\circ C$		2	7		2	7	mV
Input Bias Current	$I_{IN(+)}$ or $I_{IN(-)}$, $T_A = 25^\circ C$, $V_{CM} = 0V$, (Note 6)		45	250		45	250	nA
Input Offset Current	$I_{IN(+)} - I_{IN(-)}$, $V_{CM} = 0V$, $T_A = 25^\circ C$		5	50		5	50	nA
Input Common-Mode Voltage Range	$V^+ = 30V$, (Note 7) (LM2904, $V^+ = 26V$), $T_A = 25^\circ C$	0		$V^+ - 1.5$	0		$V^+ - 1.5$	V
Supply Current	Over Full Temperature Range $R_L = \infty$ on All Op Amps $V^+ = 30V$ (LM2904 $V^+ = 26V$) $V^+ = 5V$		1 0.5	2 1.2		1 0.5	2 1.2	mA mA

Electrical Characteristics

$V^+ = +5.0V$, (Note 4), unless otherwise stated

Parameter	Conditions	LM158A			LM358A			LM158/LM258			Units
		Min	Typ	Max	Min	Typ	Max	Min	Typ	Max	
Large Signal Voltage Gain	$V^+ = 15V$, $T_A = 25^\circ C$, $R_L \geq 2 k\Omega$, (For $V_O = 1V$ to $11V$)	50	100		25	100		50	100		V/mV
Common-Mode Rejection Ratio	$T_A = 25^\circ C$, $V_{CM} = 0V$ to $V^+ - 1.5V$	70	85		65	85		70	85		dB
Power Supply Rejection Ratio	$V^+ = 5V$ to $30V$ (LM2904, $V^+ = 5V$ to $26V$), $T_A = 25^\circ C$	65	100		65	100		65	100		dB
Amplifier-to-Amplifier Coupling	$f = 1 kHz$ to $20 kHz$, $T_A = 25^\circ C$ (Input Referred), (Note 8)		-120			-120			-120		dB
Output Current	Source $V_{IN^+} = 1V$, $V_{IN^-} = 0V$, $V^+ = 15V$, $V_O = 2V$, $T_A = 25^\circ C$	20	40		20	40		20	40		mA
	Sink $V_{IN^-} = 1V$, $V_{IN^+} = 0V$ $V^+ = 15V$, $T_A = 25^\circ C$, $V_O = 2V$	10	20		10	20		10	20		mA
	$V_{IN^-} = 1V$, $V_{IN^+} = 0V$ $T_A = 25^\circ C$, $V_O = 200 mV$, $V^+ = 15V$	12	50		12	50		12	50		μA
Short Circuit to Ground	$T_A = 25^\circ C$, (Note 2), $V^+ = 15V$		40	60		40	60		40	60	mA
Input Offset Voltage	(Note 5)			4			5			7	mV
Input Offset Voltage Drift	$R_S = 0\Omega$		7	15		7	20		7		$\mu V/^\circ C$
Input Offset Current	$I_{IN(+)} - I_{IN(-)}$			30			75			100	nA
Input Offset Current Drift	$R_S = 0\Omega$		10	200		10	300		10		$pA/^\circ C$
Input Bias Current	$I_{IN(+)}$ or $I_{IN(-)}$		40	100		40	200		40	300	nA
Input Common-Mode Voltage Range	$V^+ = 30 V$, (Note 7) (LM2904, $V^+ = 26V$)	0		$V^+ - 2$	0		$V^+ - 2$	0		$V^+ - 2$	V

Electrical Characteristics (Continued)V⁺ = +5.0V, (Note 4), unless otherwise stated

Parameter		Conditions	LM158A			LM358A			LM158/LM258			Units	
			Min	Typ	Max	Min	Typ	Max	Min	Typ	Max		
Large Signal Voltage Gain		V ⁺ = +15V (V _O = 1V to 11V) R _L ≥ 2 kΩ	25			15			25			V/mV	
Output Voltage Swing	V _{OH}	V ⁺ = +30V (LM2904, V ⁺ = 26V)	26			26			26			V	
	V _{OL}	R _L = 2 kΩ R _L = 10 kΩ	27	28		27	28		27	28	V		
Output Current		V ⁺ = 5V, R _L = 10 kΩ	5			20			5			20	mV
Output Current	Source	V _{IN⁺} = +1V, V _{IN⁻} = 0V, V ⁺ = 15V, V _O = 2V	10			20			10			20	mA
	Sink	V _{IN⁻} = +1V, V _{IN⁺} = 0V, V ⁺ = 15V, V _O = 2V	10			15			5			8	mA

Electrical CharacteristicsV⁺ = +5.0V, (Note 4), unless otherwise stated

Parameter		Conditions	LM358			LM2904			Units					
			Min	Typ	Max	Min	Typ	Max						
Large Signal Voltage Gain		V ⁺ = 15V, T _A = 25°C, R _L ≥ 2 kΩ, (For V _O = 1V to 11V)	25			100			25		100	V/mV		
Common-Mode Rejection Ratio		T _A = 25°C, V _{CM} = 0V to V ⁺ -1.5V	65			85			50		70	dB		
Power Supply Rejection Ratio		V ⁺ = 5V to 30V (LM2904, V ⁺ = 5V to 26V), T _A = 25°C	65			100			50		100	dB		
Amplifier-to-Amplifier Coupling		f = 1 kHz to 20 kHz, T _A = 25°C (Input Referred), (Note 8)				-120					-120	dB		
Output Current	Source	V _{IN⁺} = 1V, V _{IN⁻} = 0V, V ⁺ = 15V, V _O = 2V, T _A = 25°C	20			40			20		40	mA		
	Sink	V _{IN⁻} = 1V, V _{IN⁺} = 0V V ⁺ = 15V, T _A = 25°C, V _O = 2V	10			20			10		20	mA		
		V _{IN⁻} = 1V, V _{IN⁺} = 0V T _A = 25°C, V _O = 200 mV, V ⁺ = 15V	12			50			12		50	μA		
Short Circuit to Ground		T _A = 25°C, (Note 2), V ⁺ = 15V				40			60			40	60	mA
Input Offset Voltage		(Note 5)				9					10	mV		
Input Offset Voltage Drift		R _S = 0Ω				7					7	μV/°C		
Input Offset Current		I _{IN(+)} - I _{IN(-)}				150			45		200	nA		
Input Offset Current Drift		R _S = 0Ω				10					10	pA/°C		
Input Bias Current		I _{IN(+)} or I _{IN(-)}				40			500			nA		
Input Common-Mode Voltage Range		V ⁺ = 30 V, (Note 7) (LM2904, V ⁺ = 26V)	0			V ⁺ -2			0		V ⁺ -2	V		

Electrical Characteristics (Continued)

$V^+ = +5.0V$, (Note 4), unless otherwise stated

Parameter		Conditions	LM358			LM2904			Units
			Min	Typ	Max	Min	Typ	Max	
Large Signal Voltage Gain		$V^+ = +15V$ ($V_O = 1V$ to $11V$) $R_L \geq 2\text{ k}\Omega$	15			15			V/mV
Output Voltage Swing	V_{OH}	$V^+ = +30V$ (LM2904, $V^+ = 26V$)	$R_L = 2\text{ k}\Omega$ 26		22		V		
	V_{OL}	$V^+ = 5V, R_L = 10\text{ k}\Omega$	27	28	23	24			
Output Current		Source: $V_{IN}^+ = +1V, V_{IN}^- = 0V,$ $V^+ = 15V, V_O = 2V$	10	20	10	20	mA		
		Sink: $V_{IN}^- = +1V, V_{IN}^+ = 0V,$ $V^+ = 15V, V_O = 2V$	5	8	5	8	mA		

Note 1: For operating at high temperatures, the LM358/LM358A, LM2904 must be derated based on a $+125^\circ\text{C}$ maximum junction temperature and a thermal resistance of 120°C/W for MDIP, 182°C/W for Metal Can, 189°C/W for Small Outline package, and 230°C/W for micro SMD, which applies for the device soldered in a printed circuit board, operating in a still air ambient. The LM258/LM258A and LM158/LM158A can be derated based on a $+150^\circ\text{C}$ maximum junction temperature. The dissipation is the total of both amplifiers — use external resistors, where possible, to allow the amplifier to saturate or to reduce the power which is dissipated in the integrated circuit.

Note 2: Short circuits from the output to V^+ can cause excessive heating and eventual destruction. When considering short circuits to ground, the maximum output current is approximately 40 mA independent of the magnitude of V^+ . At values of supply voltage in excess of +15V, continuous short-circuits can exceed the power dissipation ratings and cause eventual destruction. Destructive dissipation can result from simultaneous shorts on all amplifiers.

Note 3: This input current will only exist when the voltage at any of the input leads is driven negative. It is due to the collector-base junction of the input PNP transistors becoming forward biased and thereby acting as input diode clamps. In addition to this diode action, there is also lateral NPN parasitic transistor action on the IC chip. This transistor action can cause the output voltages of the op amps to go to the V^+ voltage level (or to ground for a large overdrive) for the time duration that an input is driven negative. This is not destructive and normal output states will re-establish when the input voltage, which was negative, again returns to a value greater than $-0.3V$ (at 25°C).

Note 4: These specifications are limited to $-55^\circ\text{C} \leq T_A \leq +125^\circ\text{C}$ for the LM158/LM158A. With the LM258/LM258A, all temperature specifications are limited to $-25^\circ\text{C} \leq T_A \leq +85^\circ\text{C}$, the LM358/LM358A temperature specifications are limited to $0^\circ\text{C} \leq T_A \leq +70^\circ\text{C}$, and the LM2904 specifications are limited to $-40^\circ\text{C} \leq T_A \leq +85^\circ\text{C}$.

Note 5: $V_O = 1.4V, R_S = 0\Omega$ with V^+ from 5V to 30V; and over the full input common-mode range (0V to $V^+ - 1.5V$) at 25°C . For LM2904, V^+ from 5V to 26V.

Note 6: The direction of the input current is out of the IC due to the PNP input stage. This current is essentially constant, independent of the state of the output so no loading change exists on the input lines.

Note 7: The input common-mode voltage of either input signal voltage should not be allowed to go negative by more than 0.3V (at 25°C). The upper end of the common-mode voltage range is $V^+ - 1.5V$ (at 25°C), but either or both inputs can go to +32V without damage (+26V for LM2904), independent of the magnitude of V^+ .

Note 8: Due to proximity of external components, insure that coupling is not originating via stray capacitance between these external parts. This typically can be detected as this type of capacitance increases at higher frequencies.

Note 9: Refer to RETS158AX for LM158A military specifications and to RETS158X for LM158 military specifications.

Note 10: Human body model, 1.5 k Ω in series with 100 pF.

Typical Performance Characteristics

Input Voltage Range

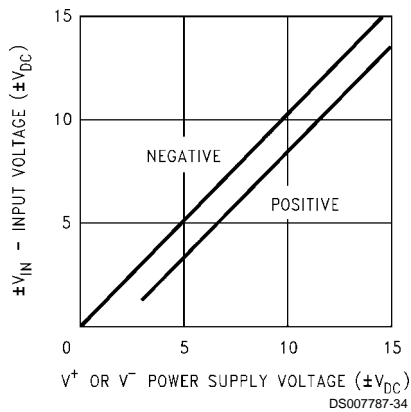

Input Current

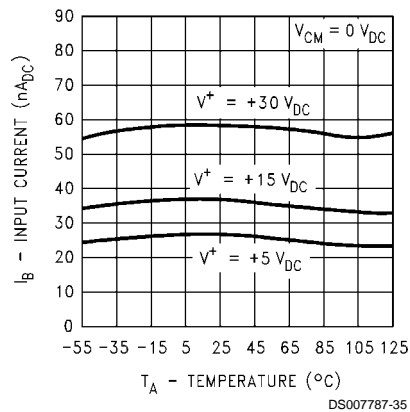

Typical Performance Characteristics (Continued)

Supply Current

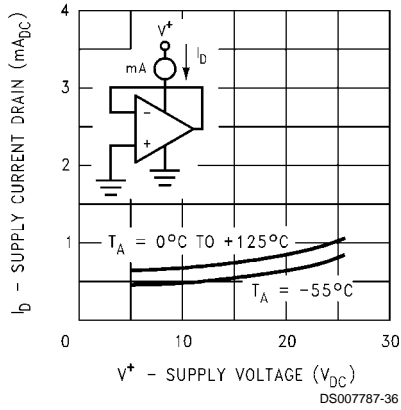

Voltage Gain

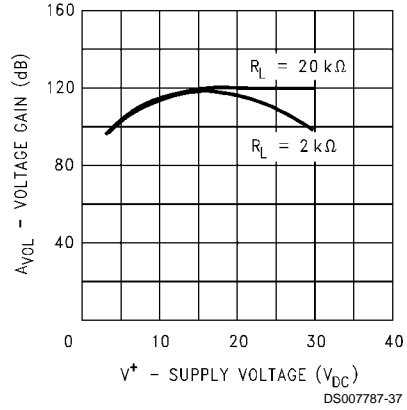

Open Loop Frequency Response

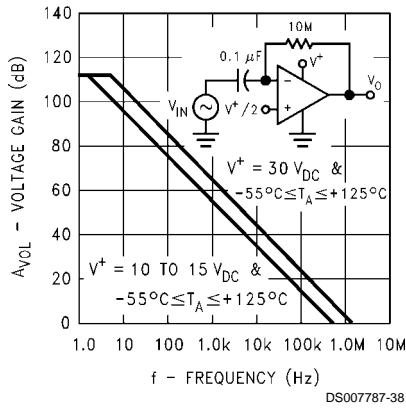

Common-Mode Rejection Ratio

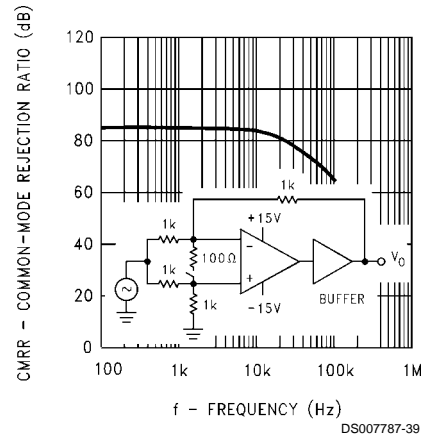

Voltage Follower Pulse Response

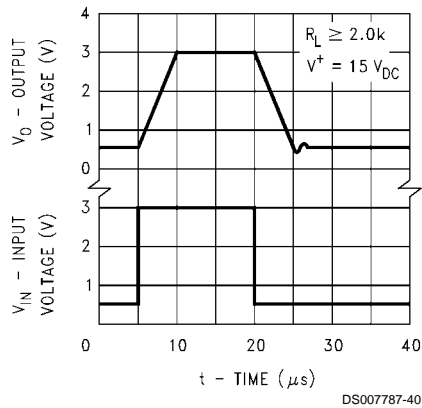

Voltage Follower Pulse Response (Small Signal)

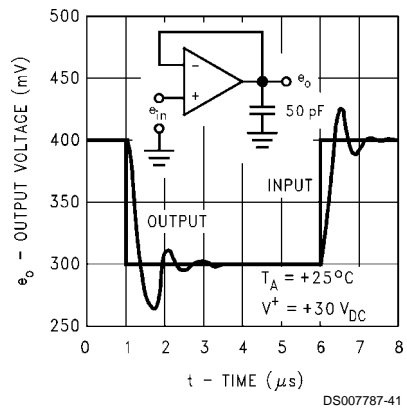

Typical Performance Characteristics (Continued)

Large Signal Frequency Response

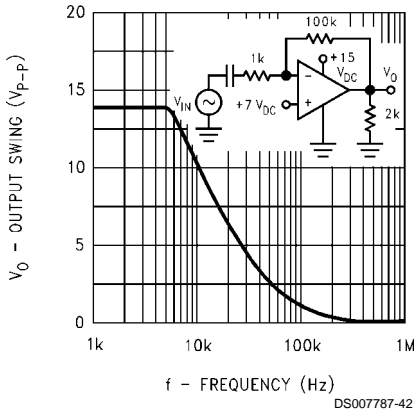

Output Characteristics Current Sourcing

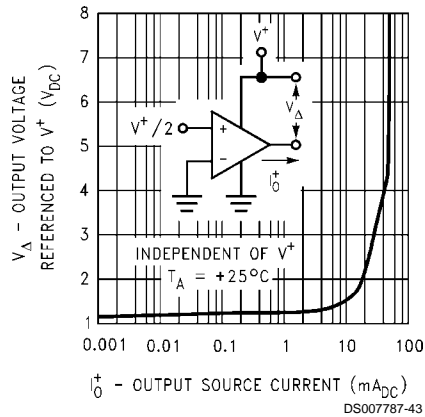

Output Characteristics Current Sinking

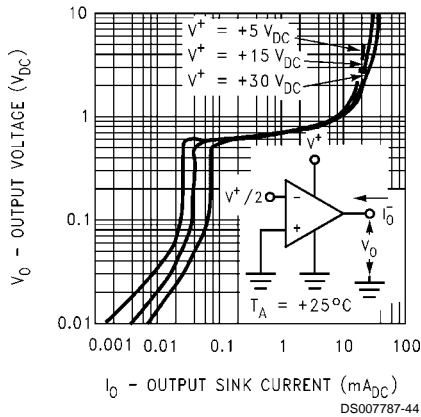

Current Limiting

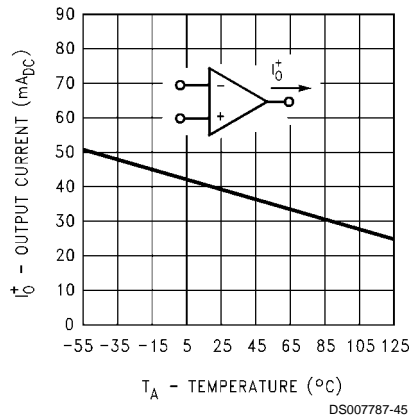

Input Current (LM2902 only)

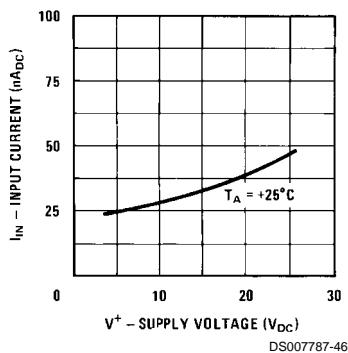

Voltage Gain (LM2902 only)

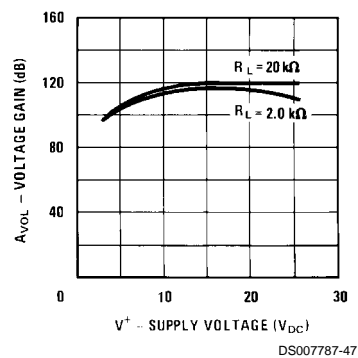

Application Hints

The LM158 series are op amps which operate with only a single power supply voltage, have true-differential inputs, and remain in the linear mode with an input common-mode voltage of $0V_{DC}$. These amplifiers operate over a wide range of power supply voltage with little change in performance characteristics. At 25°C amplifier operation is possible down to a minimum supply voltage of $2.3V_{DC}$.

Precautions should be taken to insure that the power supply for the integrated circuit never becomes reversed in polarity or that the unit is not inadvertently installed backwards in a test socket as an unlimited current surge through the resulting forward diode within the IC could cause fusing of the internal conductors and result in a destroyed unit.

Large differential input voltages can be easily accommodated and, as input differential voltage protection diodes are not needed, no large input currents result from large differential input voltages. The differential input voltage may be larger

Application Hints (Continued)

than V^+ without damaging the device. Protection should be provided to prevent the input voltages from going negative more than $-0.3 V_{DC}$ (at 25°C). An input clamp diode with a resistor to the IC input terminal can be used.

To reduce the power supply current drain, the amplifiers have a class A output stage for small signal levels which converts to class B in a large signal mode. This allows the amplifiers to both source and sink large output currents. Therefore both NPN and PNP external current boost transistors can be used to extend the power capability of the basic amplifiers. The output voltage needs to raise approximately 1 diode drop above ground to bias the on-chip vertical PNP transistor for output current sinking applications.

For ac applications, where the load is capacitively coupled to the output of the amplifier, a resistor should be used, from the output of the amplifier to ground to increase the class A bias current and prevent crossover distortion. Where the load is directly coupled, as in dc applications, there is no crossover distortion.

Capacitive loads which are applied directly to the output of the amplifier reduce the loop stability margin. Values of 50 pF can be accommodated using the worst-case non-inverting unity gain connection. Large closed loop gains or resistive isolation should be used if larger load capacitance must be driven by the amplifier.

The bias network of the LM158 establishes a drain current which is independent of the magnitude of the power supply voltage over the range of $3 V_{DC}$ to $30 V_{DC}$.

Output short circuits either to ground or to the positive power supply should be of short time duration. Units can be destroyed, not as a result of the short circuit current causing metal fusing, but rather due to the large increase in IC chip dissipation which will cause eventual failure due to excessive junction temperatures. Putting direct short-circuits on more than one amplifier at a time will increase the total IC power dissipation to destructive levels, if not properly protected with external dissipation limiting resistors in series with the output leads of the amplifiers. The larger value of output source current which is available at 25°C provides a larger output current capability at elevated temperatures (see typical performance characteristics) than a standard IC op amp.

The circuits presented in the section on typical applications emphasize operation on only a single power supply voltage. If complementary power supplies are available, all of the standard op amp circuits can be used. In general, introducing a pseudo-ground (a bias voltage reference of $V^+/2$) will allow operation above and below this value in single power supply systems. Many application circuits are shown which take advantage of the wide input common-mode voltage range which includes ground. In most cases, input biasing is not required and input voltages which range to ground can easily be accommodated.

Connection Diagrams

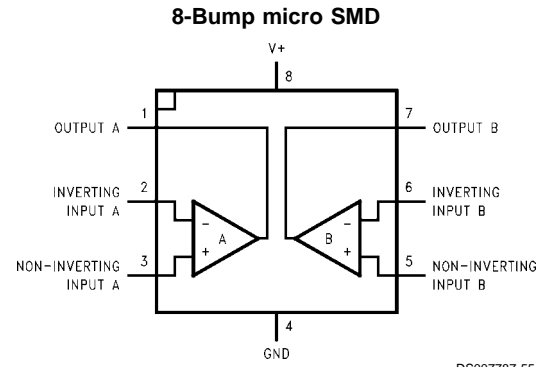

**Top View
(Bump Side Down)**

micro SMD Marking Orientation

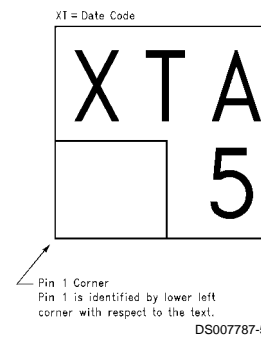

Bumps are numbered counter-clockwise.

Top View

Metal Can Package

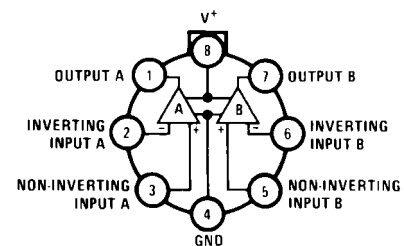

Top View

Connection Diagrams (Continued)

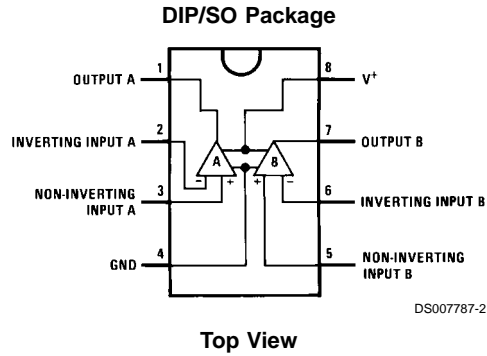

Ordering Information

Package	Temperature Range				NSC Drawing
	-55°C to 125°C	-25°C to 85°C	0°C to 70°C	-40°C to 85°C	
SO-8			LM358AM LM358AMX LM358M LM358MX	LM2904M	M08A
8-Pin Molded DIP			LM358AN LM358N	LM2904N	N08E
8-Pin Ceramic DIP	LM158AJ/883(Note 11) LM158J/883(Note 11) LM158J LM158AJLQML(Note 12) LM158AJQMLV(Note 12)				J08A
TO-5, 8-Pin Metal Can	LM158AH/883(Note 11) LM158H/883(Note 11) LM158AH LM158H LM158AHLQML(Note 12) LM158AHLQMLV(Note 12)	LM258H	LM358H		H08C
8-Bump micro SMD			LM358BP LM358BPX		BPA08AAB

Note 11: LM158 is available per SMD #5962-8771001

LM158A is available per SMD #5962-8771002

Note 12: See STD Mil DWG 5962L87710 for Radiation Tolerant Devices

Typical Single-Supply Applications $(V^+ = 5.0 V_{DC})$

Non-Inverting DC Gain (0V Output)

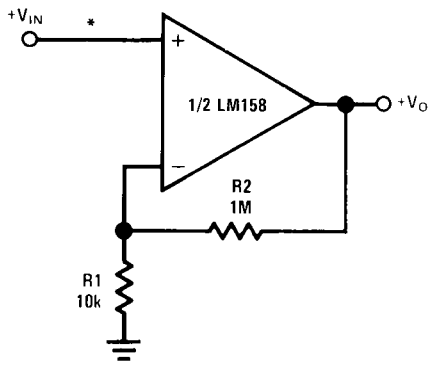

DS007787-6

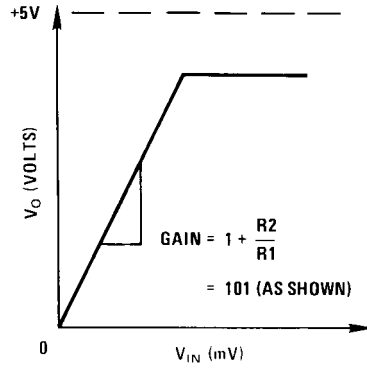

DS007787-7

*R not needed due to temperature independent I_{IN}

DC Summing Amplifier ($V_{IN'S} \geq 0 V_{DC}$ and $V_O \geq 0 V_{DC}$)

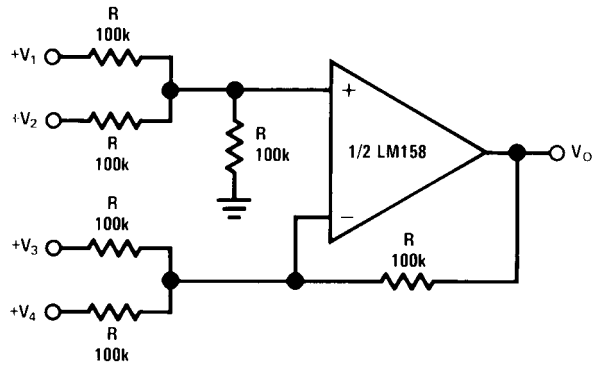

DS007787-8

Where: $V_O = V_1 + V_2 + V_3 + V_4$
 $(V_1 + V_2) \geq (V_3 + V_4)$ to keep $V_O > 0 V_{DC}$

Power Amplifier

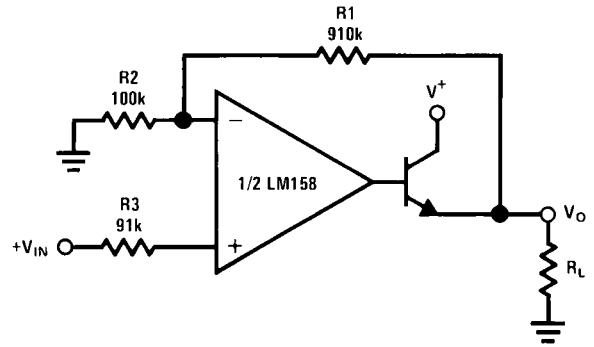

DS007787-9

$V_O = 0 V_{DC}$ for $V_{IN} = 0 V_{DC}$
 $A_V = 10$

Typical Single-Supply Applications ($V^+ = 5.0 V_{DC}$) (Continued)

“BI-QUAD” RC Active Bandpass Filter

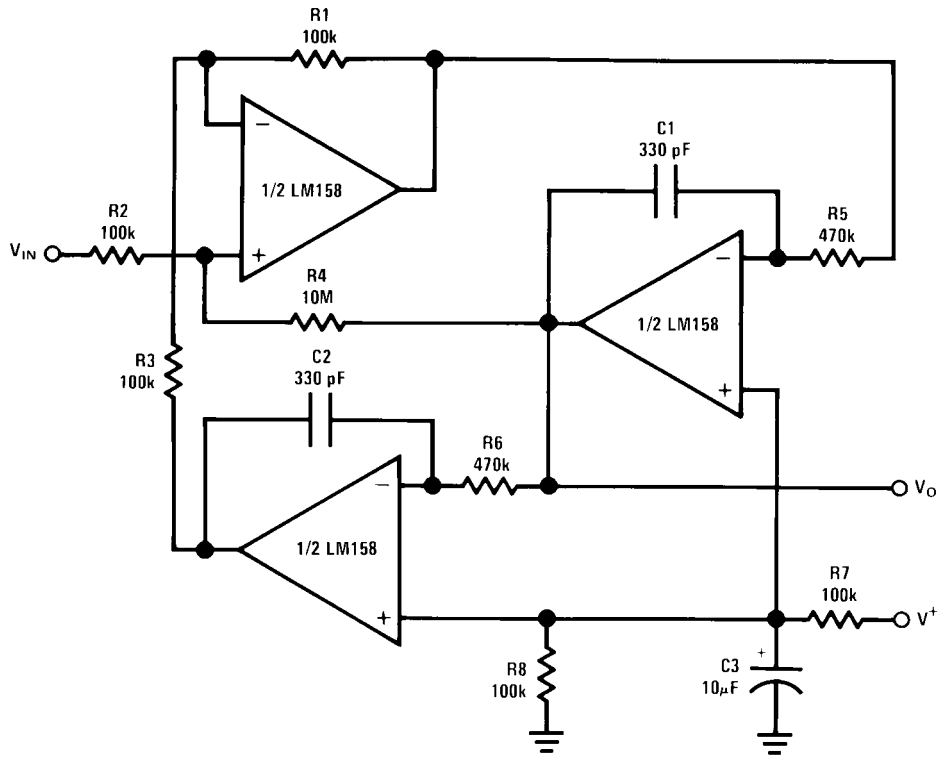

DS007787-10

$f_o = 1 \text{ kHz}$
 $Q = 50$
 $A_v = 100 \text{ (40 dB)}$

Fixed Current Sources

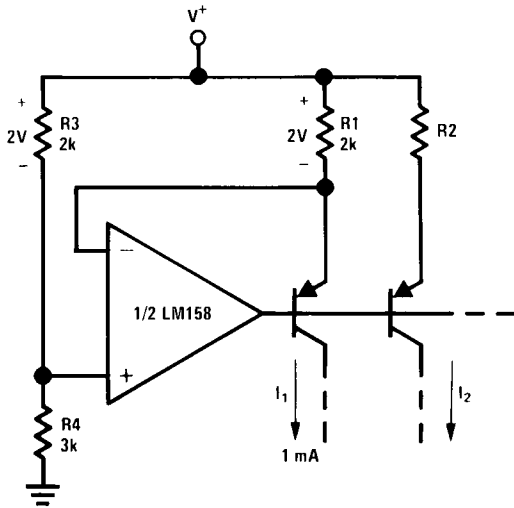

DS007787-11

$$I_2 = \left(\frac{R_1}{R_2} \right) I_1$$

Lamp Driver

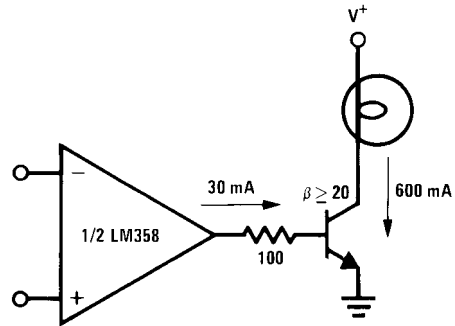

DS007787-12

Typical Single-Supply Applications ($V^+ = 5.0 V_{DC}$) (Continued)

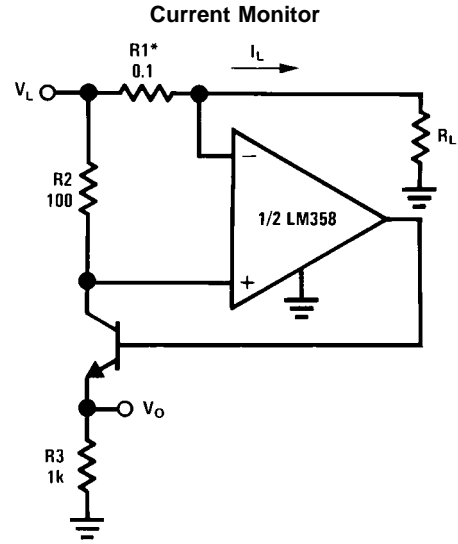
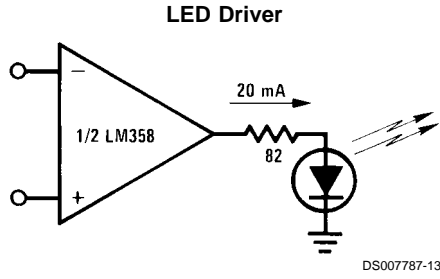

$$V_O = \frac{1V (I_L)}{1A}$$

*(Increase R1 for I_L small)
 $V_L \leq V^+ - 2V$

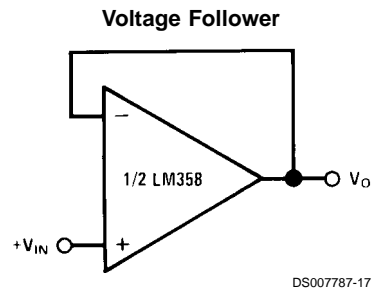
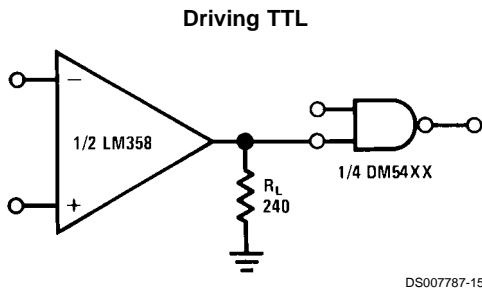

$$V_O = V_{IN}$$

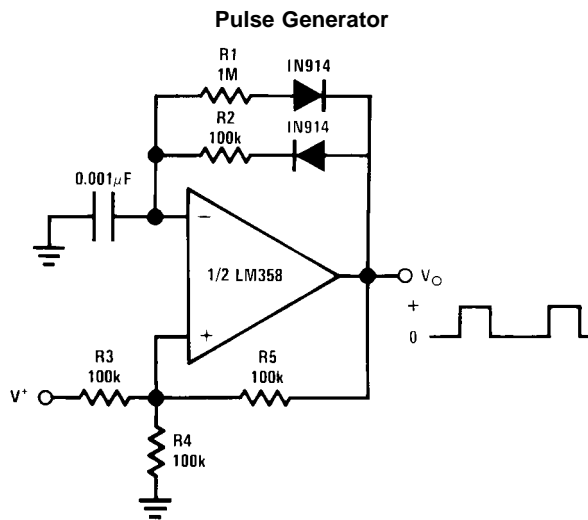

Typical Single-Supply Applications ($V^+ = 5.0 V_{DC}$) (Continued)

Squarewave Oscillator

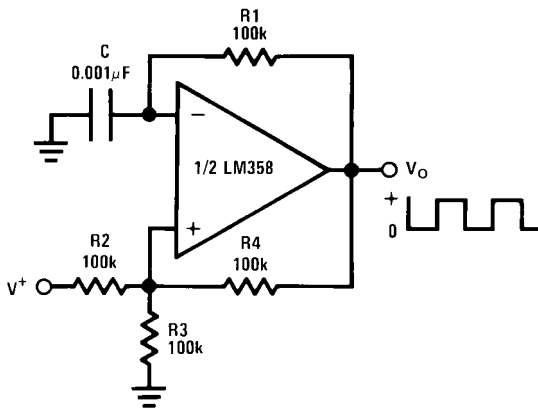

DS007787-18

Pulse Generator

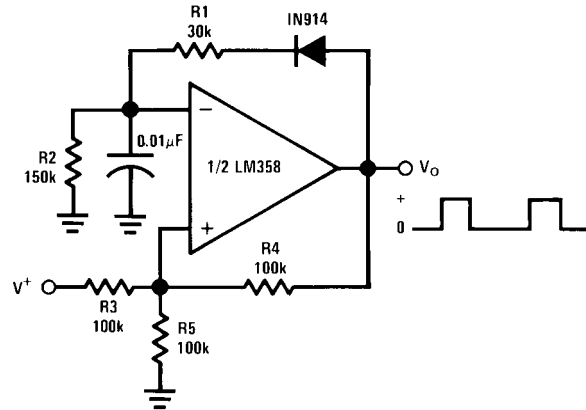

DS007787-19

Low Drift Peak Detector

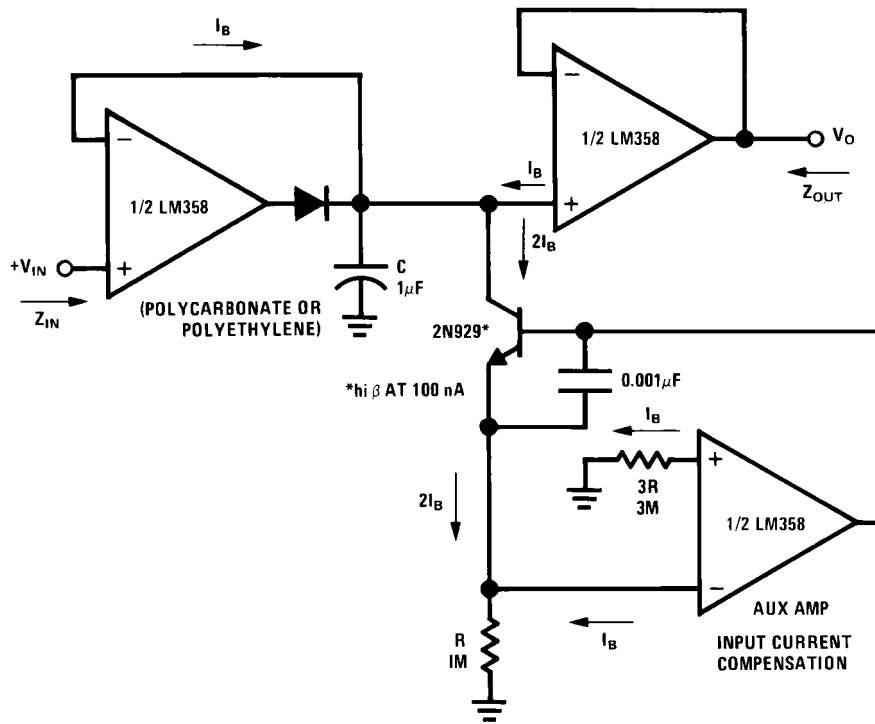

DS007787-20

HIGH Z_{IN}
LOW Z_{OUT}

Typical Single-Supply Applications ($V^+ = 5.0 V_{DC}$) (Continued)

High Compliance Current Sink

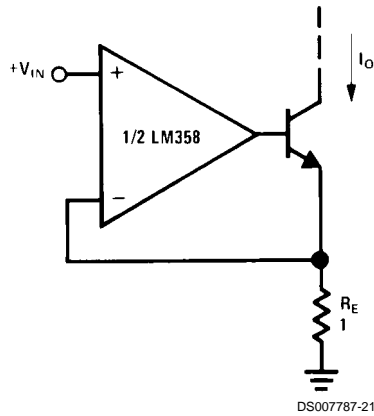

DS007787-21

$I_O = 1 \text{ amp/volt } V_{IN}$
(Increase R_E for I_O small)

Comparator with Hysteresis

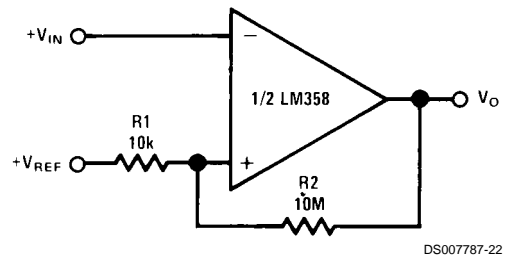

DS007787-22

Voltage Controlled Oscillator (VCO)

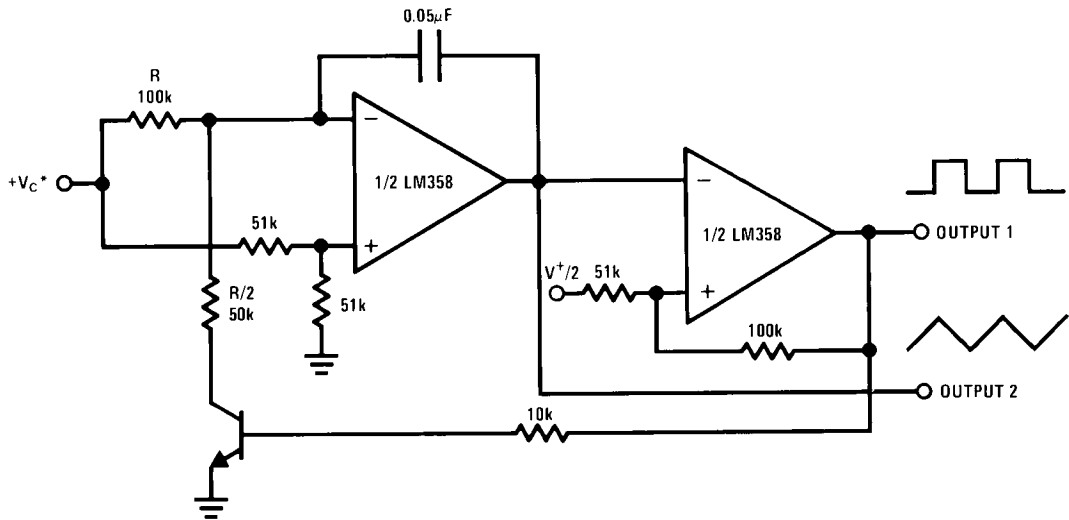

DS007787-23

*WIDE CONTROL VOLTAGE RANGE: $0 V_{DC} \leq V_C \leq 2 (V^+ - 1.5V_{DC})$

Typical Single-Supply Applications ($V^+ = 5.0 V_{DC}$) (Continued)

AC Coupled Inverting Amplifier

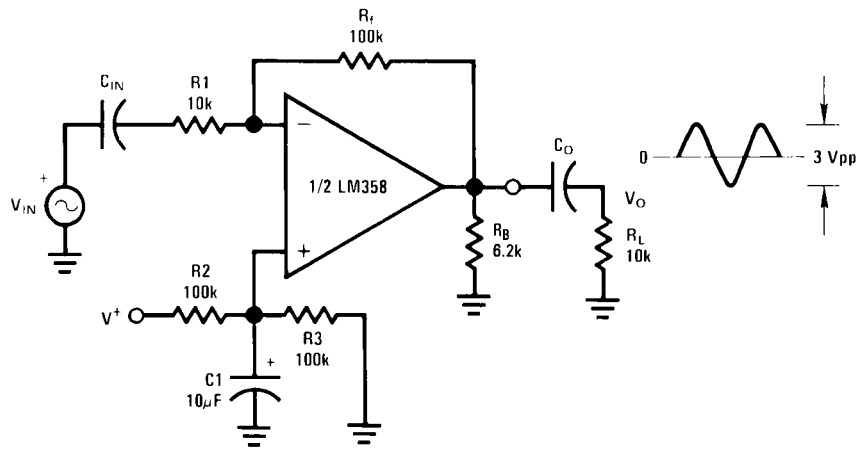

DS007787-24

$$A_V = \frac{R_f}{R_1} \quad (\text{As shown, } A_V = 10)$$

Ground Referencing a Differential Input Signal

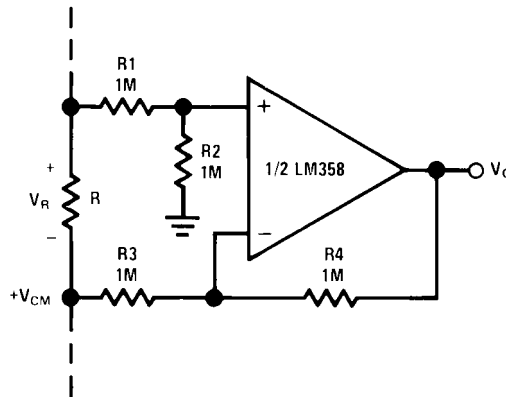

DS007787-25

Typical Single-Supply Applications ($V^+ = 5.0 V_{DC}$) (Continued)

AC Coupled Non-Inverting Amplifier

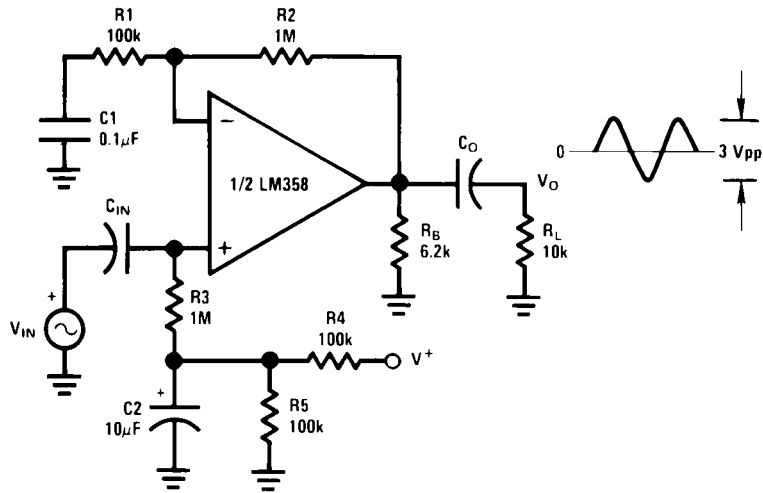

DS007787-26

$$A_V = 1 + \frac{R_2}{R_1}$$

$A_V = 11$ (As Shown)

DC Coupled Low-Pass RC Active Filter

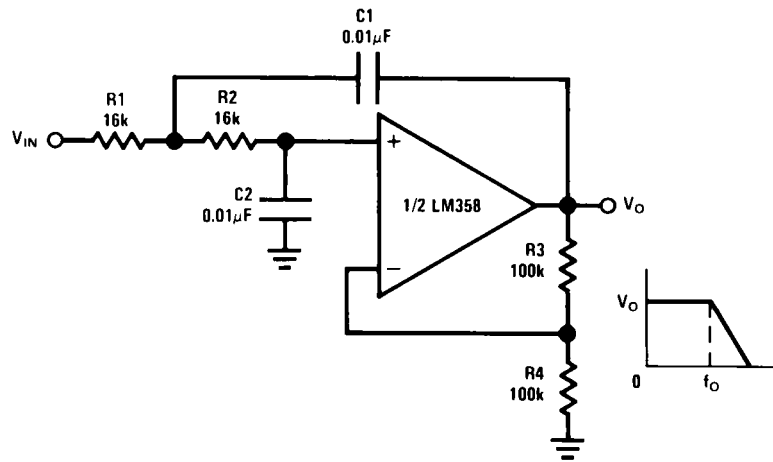

DS007787-27

$f_o = 1 \text{ kHz}$
 $Q = 1$
 $A_V = 2$

Typical Single-Supply Applications ($V^+ = 5.0 V_{DC}$) (Continued)

Bandpass Active Filter

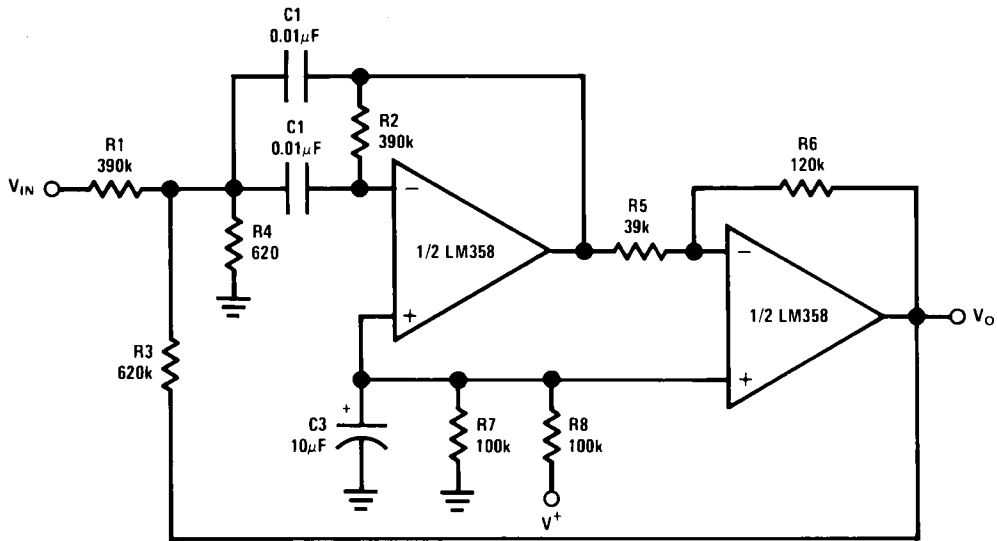

DS007787-28

$f_o = 1 \text{ kHz}$
 $Q = 25$

High Input Z, DC Differential Amplifier

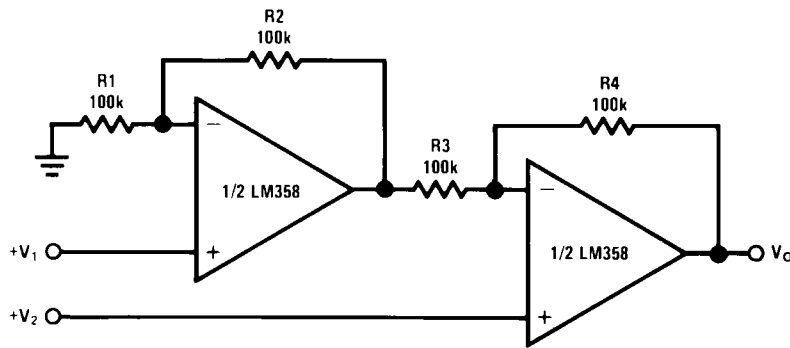

DS007787-29

For $\frac{R1}{R2} = \frac{R4}{R3}$ (CMRR depends on this resistor ratio match)

$$V_O = 1 + \frac{R4}{R3} (V_2 - V_1)$$

As Shown: $V_O = 2 (V_2 - V_1)$

Typical Single-Supply Applications ($V^+ = 5.0 V_{DC}$) (Continued)

Photo Voltaic-Cell Amplifier

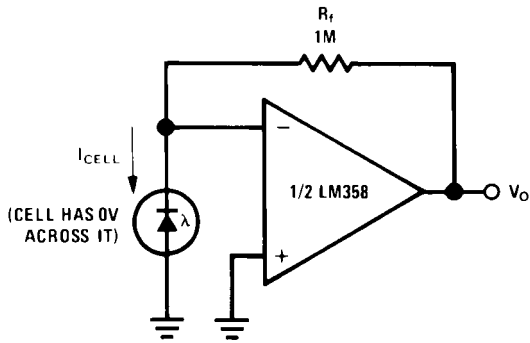

DS007787-30

Bridge Current Amplifier

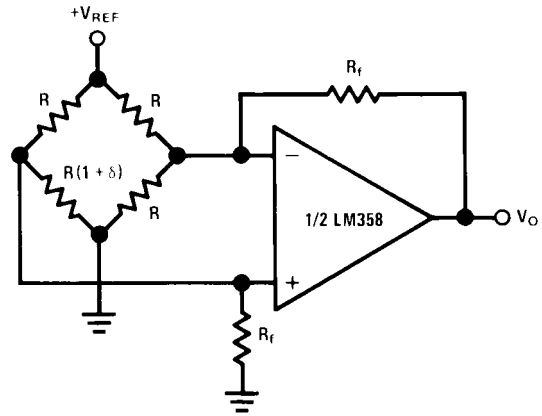

DS007787-33

For $\delta \ll 1$ and $R_f \gg R$

$$V_O \approx V_{REF} \left(\frac{\delta}{2} \right) \frac{R_f}{R}$$

High Input Z Adjustable-Gain DC Instrumentation Amplifier

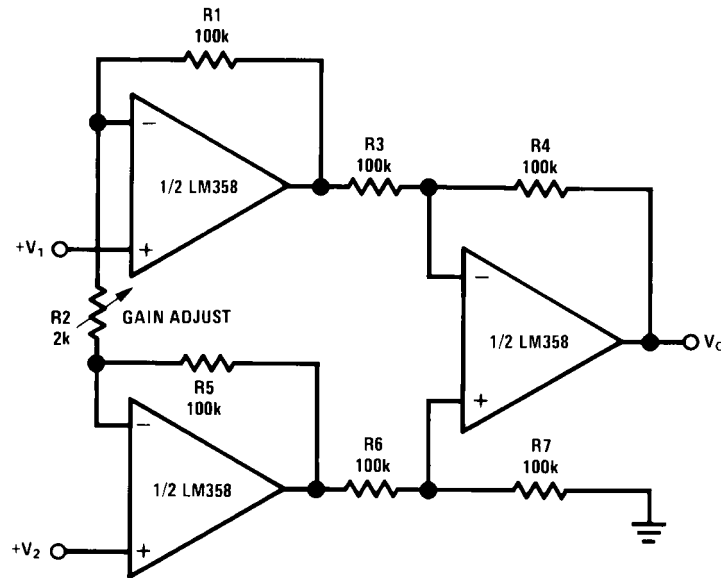

DS007787-31

If $R1 = R5$ & $R3 = R4 = R6 = R7$ (CMRR depends on match)

$$V_O = 1 + \frac{2R1}{R2} (V_2 - V_1)$$

As shown $V_O = 101 (V_2 - V_1)$

Typical Single-Supply Applications ($V^+ = 5.0 V_{DC}$) (Continued)

Using Symmetrical Amplifiers to Reduce Input Current (General Concept)

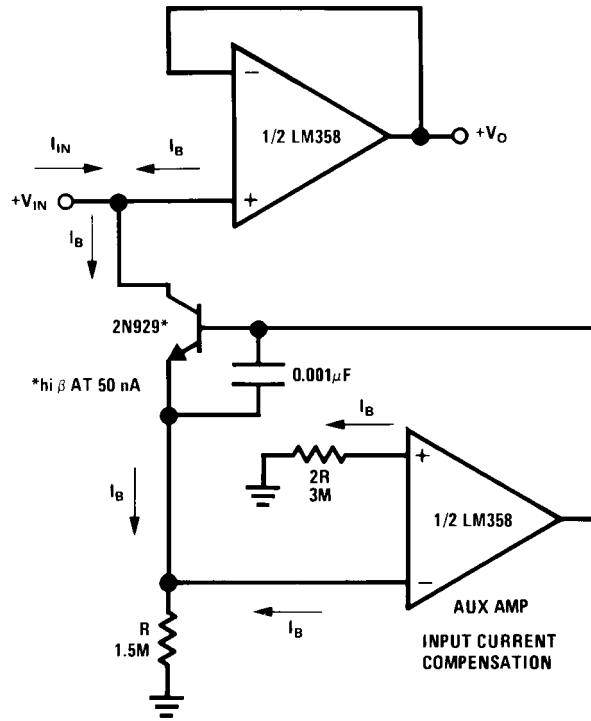

DS007787-32

Schematic Diagram (Each Amplifier)

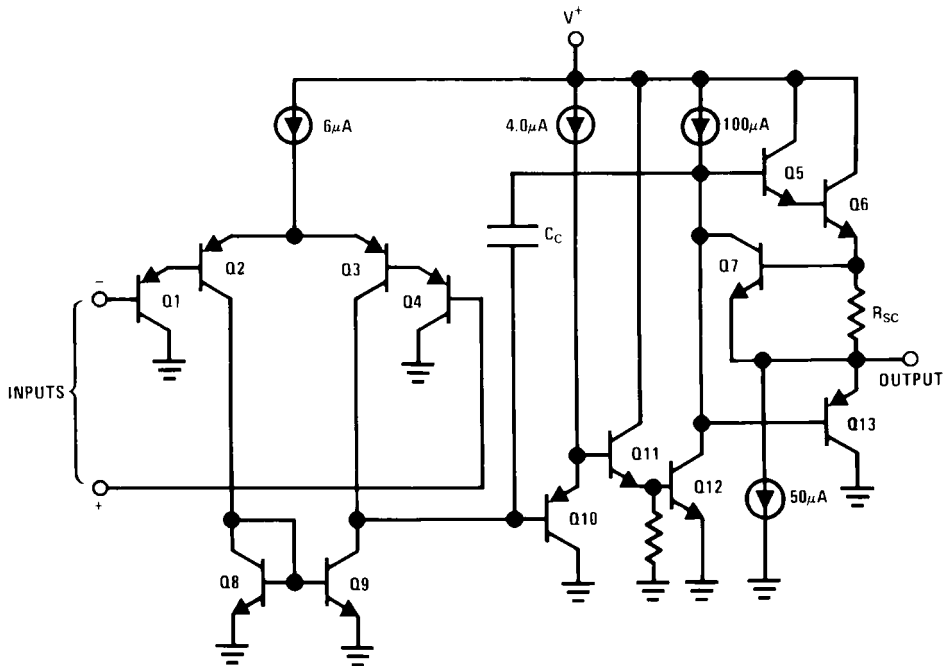

DS007787-3

Physical Dimensions inches (millimeters) unless otherwise noted

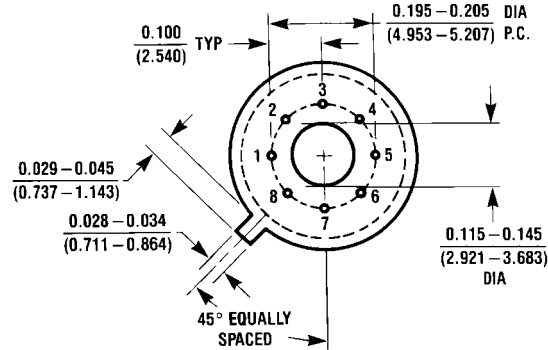
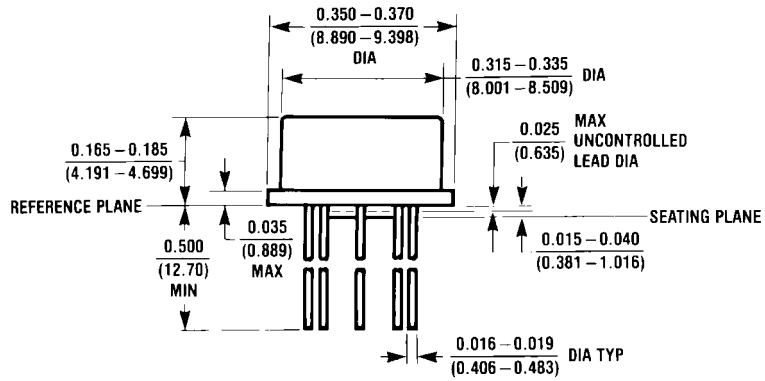

H08C (REV E)

Metal Can Package (H)
 Order Number LM158AH, LM158AH/883, LM158H,
 LM158H/883, LM258H or LM358H
 NS Package Number H08C

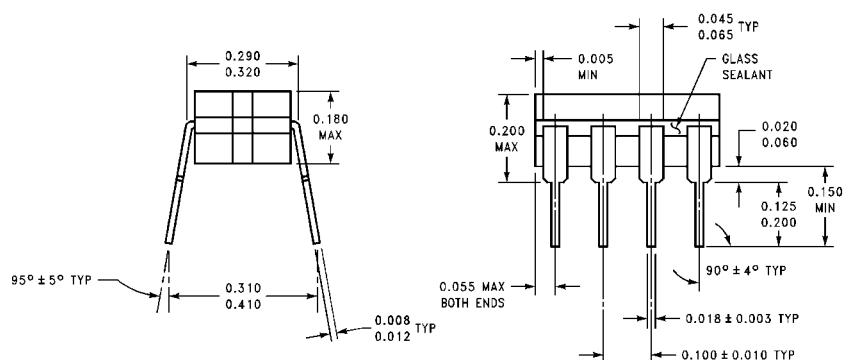
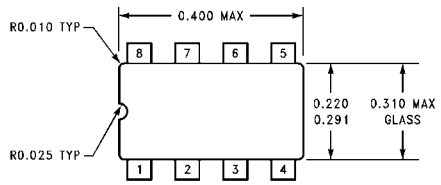

J08A (REV K)

Cerdip Package (J)
 Order Number LM158J, LM158J/883, LM158AJ or LM158AJ/883
 NS Package Number J08A

Physical Dimensions inches (millimeters) unless otherwise noted (Continued)

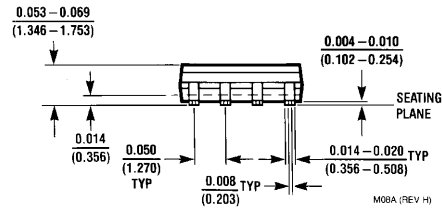
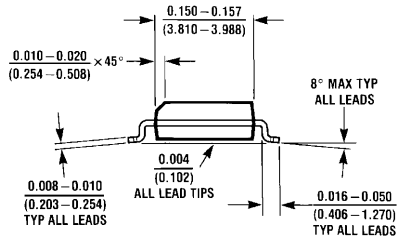
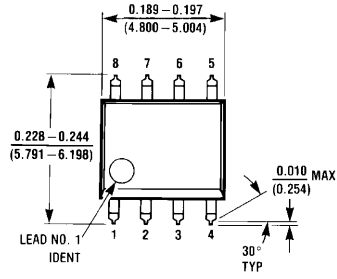

S.O. Package (M)
Order Number LM358M, LM358AM or LM2904M
NS Package Number M08A

Physical Dimensions inches (millimeters) unless otherwise noted (Continued)

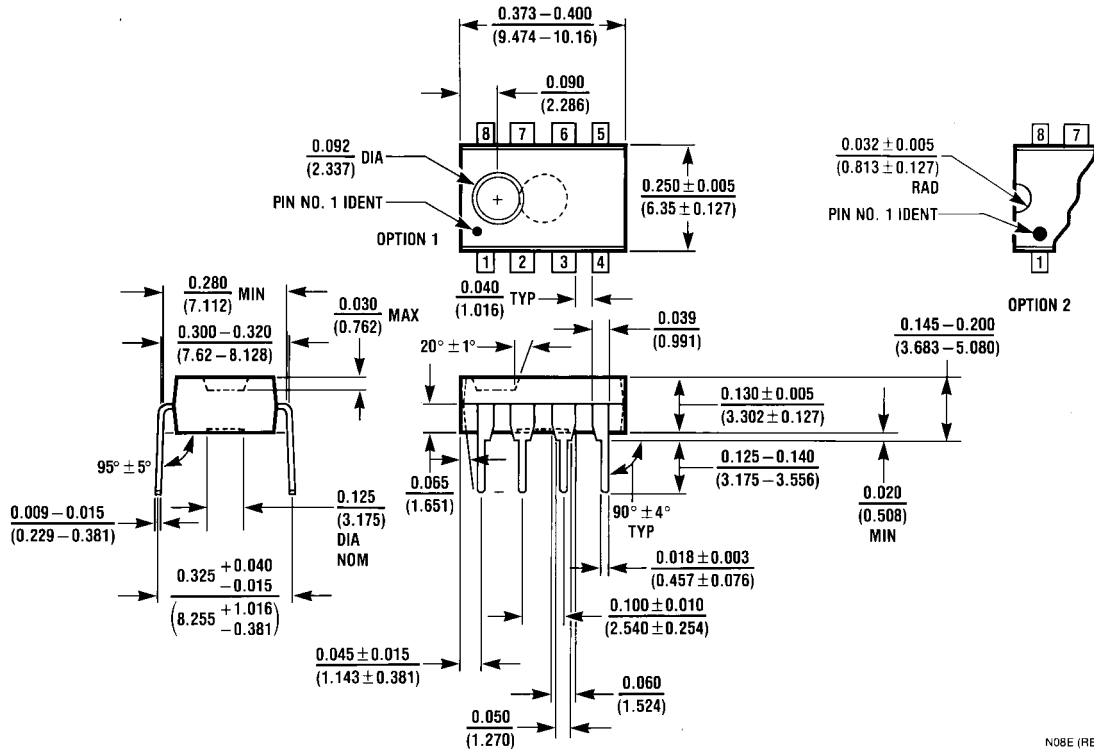

Molded Dip Package (N)
Order Number LM358AN, LM358N or LM2904N
NS Package Number N08E

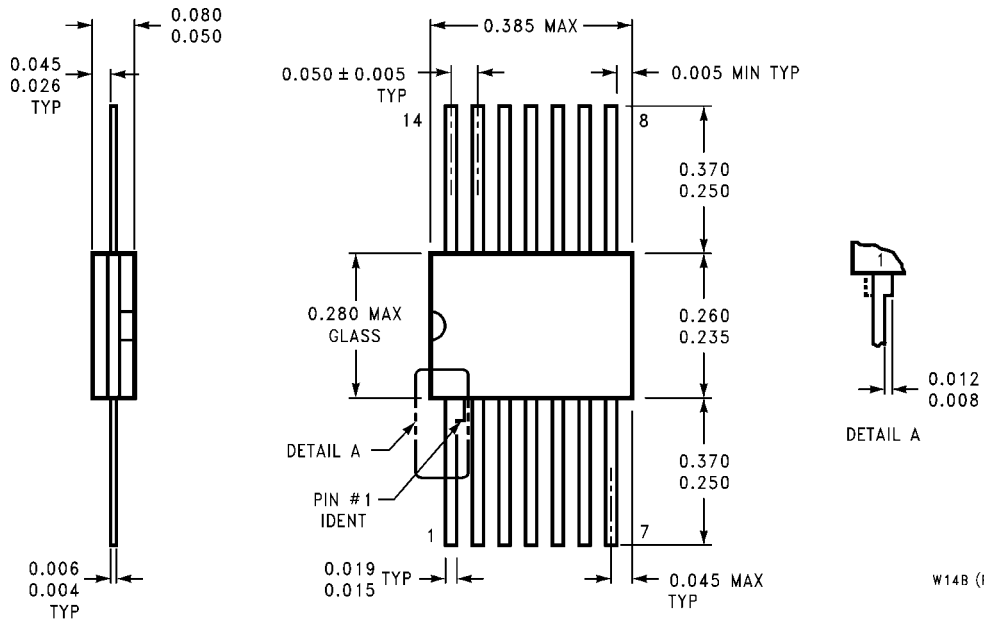

Order Number LM158AWG/883
NS Package Number W14B

Physical Dimensions inches (millimeters) unless otherwise noted (Continued)

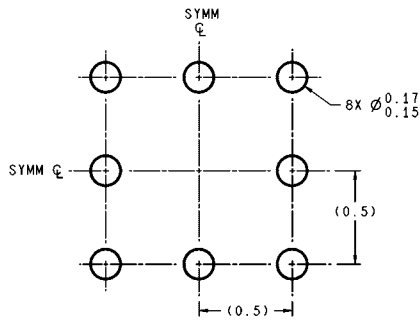

LAND PATTERN RECOMMENDATION

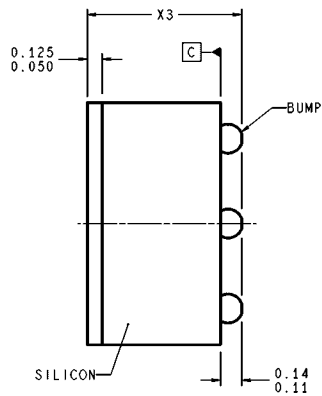
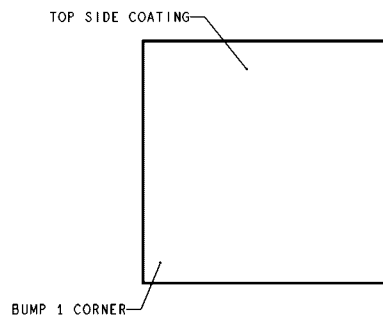

DIMENSIONS ARE IN MILLIMETERS

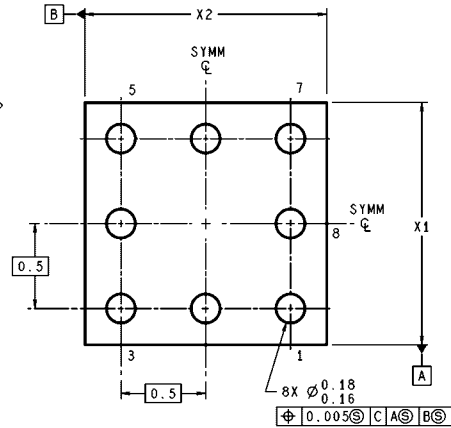

BPA08XXX (Rev B)

NOTES: UNLESS OTHERWISE SPECIFIED

1. EPOXY COATING
2. 63Sn/37Pb EUTECTIC BUMP
3. RECOMMEND NON-SOLDER MASK DEFINED LANDING PAD.
4. PIN 1 IS ESTABLISHED BY LOWER LEFT CORNER WITH RESPECT TO TEXT ORIENTATION REMAINING PINS ARE NUMBERED COUNTERCLOCKWISE.
5. XXX IN DRAWING NUMBER REPRESENTS PACKAGE SIZE VARIATION WHERE X_1 IS PACKAGE WIDTH, X_2 IS PACKAGE LENGTH AND X_3 IS PACKAGE HEIGHT.
6. REFERENCE JEDEC REGISTRATION MO-211, VARIATION BC.

8-Bump micro SMD
NS Package Number BPA08AAB
 $X_1 = 1.285$ $X_2 = 1.285$ $X_3 = 0.850$

Notes

LIFE SUPPORT POLICY

NATIONAL'S PRODUCTS ARE NOT AUTHORIZED FOR USE AS CRITICAL COMPONENTS IN LIFE SUPPORT DEVICES OR SYSTEMS WITHOUT THE EXPRESS WRITTEN APPROVAL OF THE PRESIDENT AND GENERAL COUNSEL OF NATIONAL SEMICONDUCTOR CORPORATION. As used herein:

1. Life support devices or systems are devices or systems which, (a) are intended for surgical implant into the body, or (b) support or sustain life, and whose failure to perform when properly used in accordance with instructions for use provided in the labeling, can be reasonably expected to result in a significant injury to the user.
2. A critical component is any component of a life support device or system whose failure to perform can be reasonably expected to cause the failure of the life support device or system, or to affect its safety or effectiveness.



National Semiconductor Corporation
Americas
Tel: 1-800-272-9959
Fax: 1-800-737-7018
Email: support@nsc.com
www.national.com

National Semiconductor Europe
Fax: +49 (0) 180-530 85 86
Email: europe.support@nsc.com
Deutsch Tel: +49 (0) 69 9508 6208
English Tel: +44 (0) 870 24 0 2171
Français Tel: +33 (0) 1 41 91 8790

National Semiconductor Asia Pacific Customer Response Group
Tel: 65-2544466
Fax: 65-2504466
Email: ap.support@nsc.com

National Semiconductor Japan Ltd.
Tel: 81-3-5639-7560
Fax: 81-3-5639-7507