

LF353

Wide Bandwidth Dual JFET Input Operational Amplifier

General Description

These devices are low cost, high speed, dual JFET input operational amplifiers with an internally trimmed input offset voltage (BI-FET II™ technology). They require low supply current yet maintain a large gain bandwidth product and fast slew rate. In addition, well matched high voltage JFET input devices provide very low input bias and offset currents. The LF353 is pin compatible with the standard LM1558 allowing designers to immediately upgrade the overall performance of existing LM1558 and LM358 designs.

These amplifiers may be used in applications such as high speed integrators, fast D/A converters, sample and hold circuits and many other circuits requiring low input offset voltage, low input bias current, high input impedance, high slew rate and wide bandwidth. The devices also exhibit low noise and offset voltage drift.

Features

- Internally trimmed offset voltage: 10 mV
- Low input bias current: 50pA
- Low input noise voltage: 25 nV/√Hz
- Low input noise current: 0.01 pA/√Hz
- Wide gain bandwidth: 4 MHz
- High slew rate: 13 V/μs
- Low supply current: 3.6 mA
- High input impedance: 10¹²Ω
- Low total harmonic distortion : ≤0.02%
- Low 1/f noise corner: 50 Hz
- Fast settling time to 0.01%: 2 μs

Typical Connection

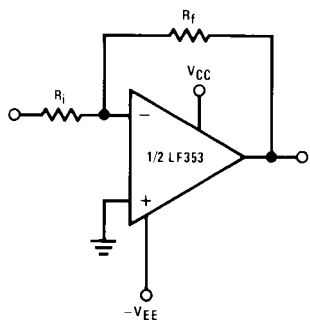

DS005649-14

Connection Diagram

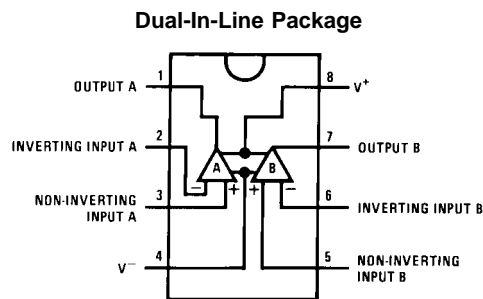

DS005649-17

Simplified Schematic

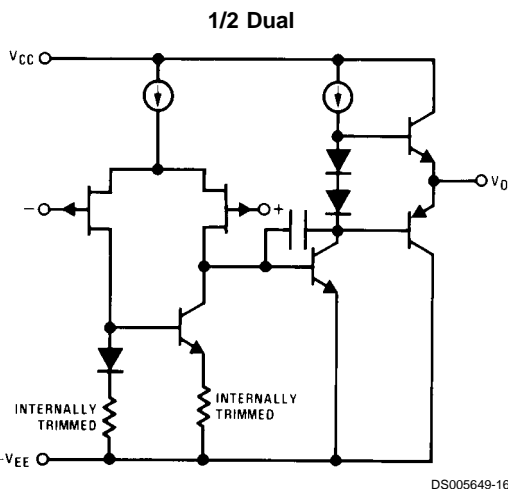

DS005649-16

Top View
Order Number LF353M, LF353MX or LF353N
See NS Package Number M08A or N08E

BI-FET II™ is a trademark of National Semiconductor Corporation.

Absolute Maximum Ratings (Note 1)

If Military/Aerospace specified devices are required, please contact the National Semiconductor Sales Office/Distributors for availability and specifications.

Supply Voltage	±18V
Power Dissipation	(Note 2)
Operating Temperature Range	0°C to +70°C
T _j (MAX)	150°C
Differential Input Voltage	±30V
Input Voltage Range (Note 3)	±15V
Output Short Circuit Duration	Continuous
Storage Temperature Range	-65°C to +150°C
Lead Temp. (Soldering, 10 sec.)	260°C
Soldering Information	
Dual-In-Line Package	
Soldering (10 sec.)	260°C

Small Outline Package

Vapor Phase (60 sec.)

215°C

Infrared (15 sec.)

220°C

See AN-450 "Surface Mounting Methods and Their Effect on Product Reliability" for other methods of soldering surface mount devices.

ESD Tolerance (Note 8)

1700V

θ_{JA} M Package

TBD

Note 1: Absolute Maximum Ratings indicate limits beyond which damage to the device may occur. Operating ratings indicate conditions for which the device is functional, but do not guarantee specific performance limits. Electrical Characteristics state DC and AC electrical specifications under particular test conditions which guarantee specific performance limits. This assumes that the device is within the Operating Ratings. Specifications are not guaranteed for parameters where no limit is given, however, the typical value is a good indication of device performance.

DC Electrical Characteristics

(Note 5)

Symbol	Parameter	Conditions	LF353			Units
			Min	Typ	Max	
V _{OS}	Input Offset Voltage	R _S =10kΩ, T _A =25°C		5	10	mV
		Over Temperature			13	mV
ΔV _{OS} /ΔT	Average TC of Input Offset Voltage	R _S =10 kΩ		10		μV/°C
I _{OS}	Input Offset Current	T _J =25°C, (Notes 5, 6)		25	100	pA
		T _J ≤70°C			4	nA
I _B	Input Bias Current	T _J =25°C, (Notes 5, 6)		50	200	pA
		T _J ≤70°C			8	nA
R _{IN}	Input Resistance	T _J =25°C		10 ¹²		Ω
A _{VOL}	Large Signal Voltage Gain	V _S =±15V, T _A =25°C	25	100		V/mV
		V _O =±10V, R _L =2 kΩ Over Temperature	15			V/mV
V _O	Output Voltage Swing	V _S =±15V, R _L =10kΩ	±12	±13.5		V
V _{CM}	Input Common-Mode Voltage Range	V _S =±15V	±11	+15		V
				-12		V
CMRR	Common-Mode Rejection Ratio	R _S ≤ 10kΩ	70	100		dB
PSRR	Supply Voltage Rejection Ratio	(Note 7)	70	100		dB
I _S	Supply Current			3.6	6.5	mA

AC Electrical Characteristics

(Note 5)

Symbol	Parameter	Conditions	LF353			Units
			Min	Typ	Max	
	Amplifier to Amplifier Coupling	T _A =25°C, f=1 Hz–20 kHz (Input Referred)		-120		dB
SR	Slew Rate	V _S =±15V, T _A =25°C	8.0	13		V/μs
GBW	Gain Bandwidth Product	V _S =±15V, T _A =25°C	2.7	4		MHz
e _n	Equivalent Input Noise Voltage	T _A =25°C, R _S =100Ω, f=1000 Hz		16		nV/√Hz
i _n	Equivalent Input Noise Current	T _J =25°C, f=1000 Hz		0.01		pA/√Hz

AC Electrical Characteristics (Continued)

(Note 5)

Symbol	Parameter	Conditions	LF353			Units
			Min	Typ	Max	
THD	Total Harmonic Distortion	$A_V=+10$, $R_L=10k$, $V_O=20Vp-p$, $BW=20\text{ Hz}-20\text{ kHz}$		<0.02		%

Note 2: For operating at elevated temperatures, the device must be derated based on a thermal resistance of 115°C/W typ junction to ambient for the N package, and 158°C/W typ junction to ambient for the H package.

Note 3: Unless otherwise specified the absolute maximum negative input voltage is equal to the negative power supply voltage.

Note 4: The power dissipation limit, however, cannot be exceeded.

Note 5: These specifications apply for $V_S=\pm 15V$ and $0^\circ C \leq T_A \leq +70^\circ C$. V_{OS} , I_B and I_{OS} are measured at $V_{CM}=0$.

Note 6: The input bias currents are junction leakage currents which approximately double for every 10°C increase in the junction temperature, T_j . Due to the limited production test time, the input bias currents measured are correlated to junction temperature. In normal operation the junction temperature rises above the ambient temperature as a result of internal power dissipation, P_D . $T_j=T_A+\theta_{jA} P_D$ where θ_{jA} is the thermal resistance from junction to ambient. Use of a heat sink is recommended if input bias current is to be kept to a minimum.

Note 7: Supply voltage rejection ratio is measured for both supply magnitudes increasing or decreasing simultaneously in accordance with common practice. $V_S = \pm 6V$ to $\pm 15V$.

Note 8: Human body model, 1.5 kΩ in series with 100 pF.

Typical Performance Characteristics

Input Bias Current

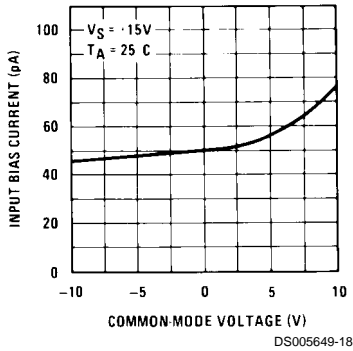

Input Bias Current

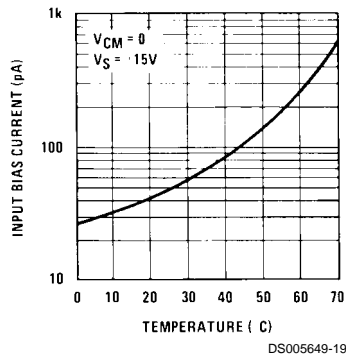

Supply Current

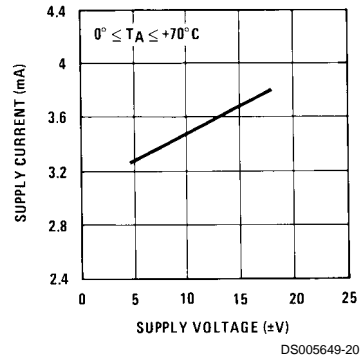

Positive Common-Mode Input Voltage Limit

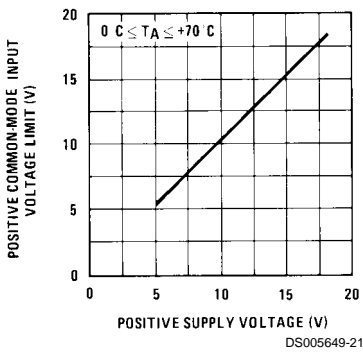

Negative Common-Mode Input Voltage Limit

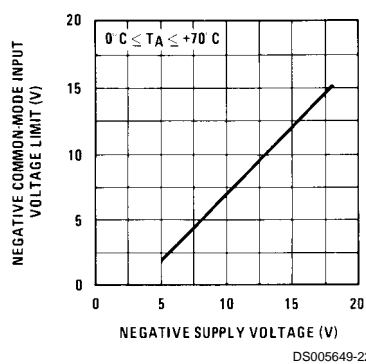

Positive Current Limit

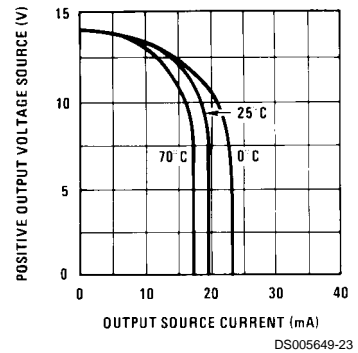

Typical Performance Characteristics (Continued)

Negative Current Limit

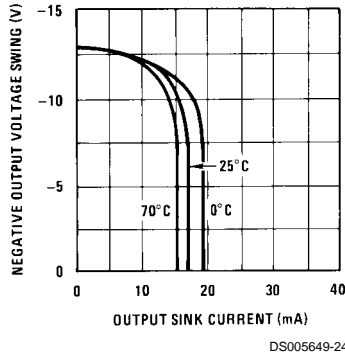

Voltage Swing

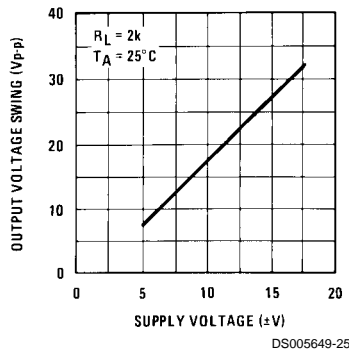

Output Voltage Swing

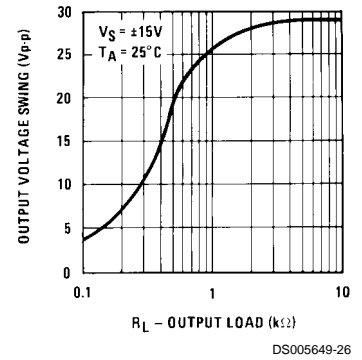

Gain Bandwidth

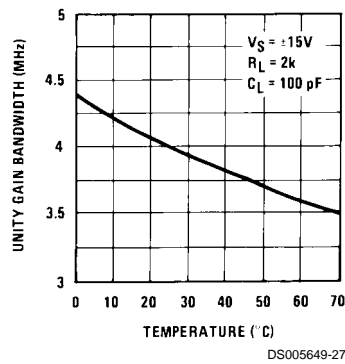

Bode Plot

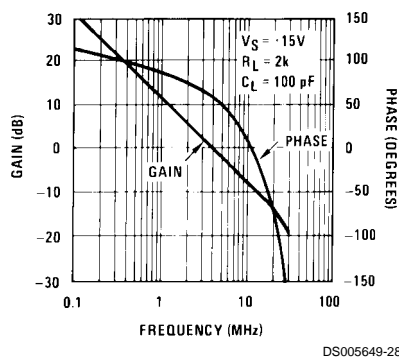

Slew Rate

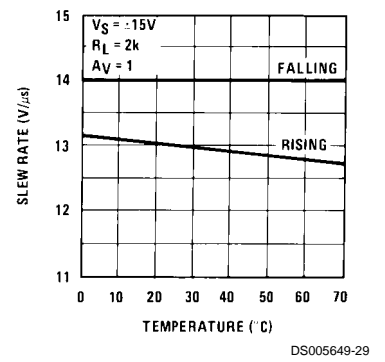

Distortion vs Frequency

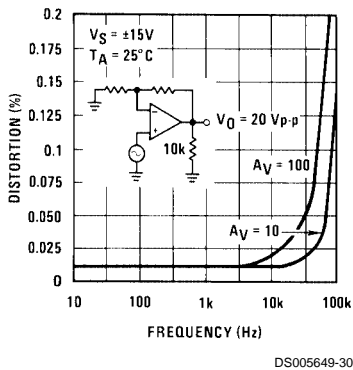

Undistorted Output Voltage Swing

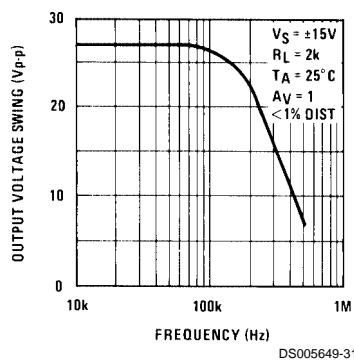

Open Loop Frequency Response

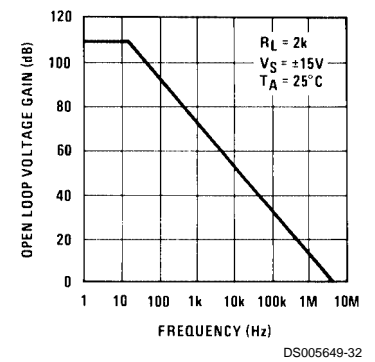

Common-Mode Rejection Ratio

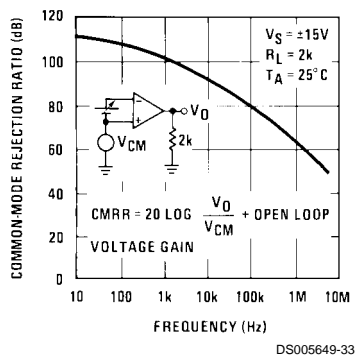

Power Supply Rejection Ratio

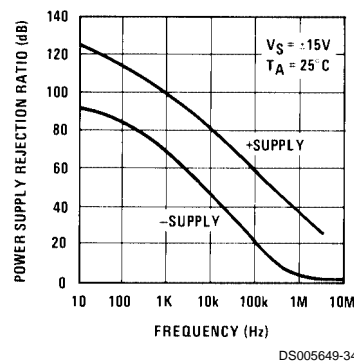

Equivalent Input Noise Voltage

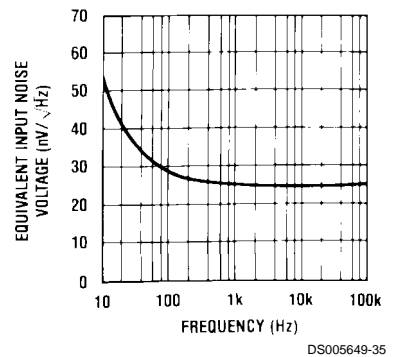

Typical Performance Characteristics (Continued)

Open Loop Voltage Gain (V/V)

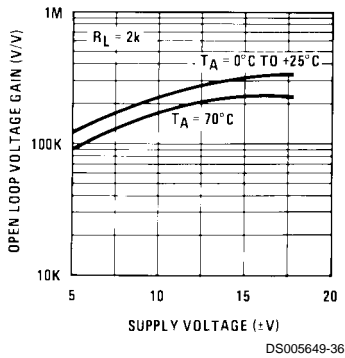

Output Impedance

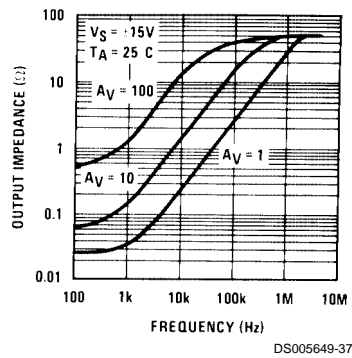

Inverter Settling Time

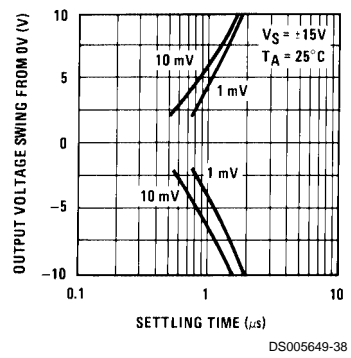

Pulse Response

Small Signaling Inverting

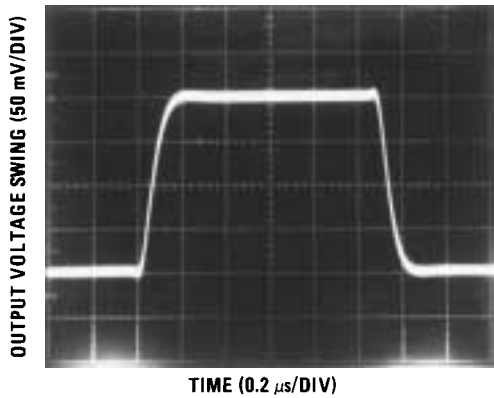

Large Signal Inverting

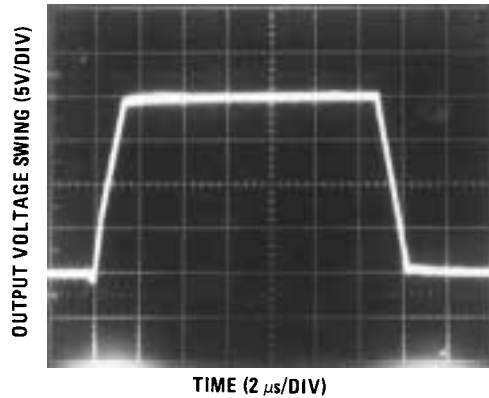

Small Signal Non-Inverting

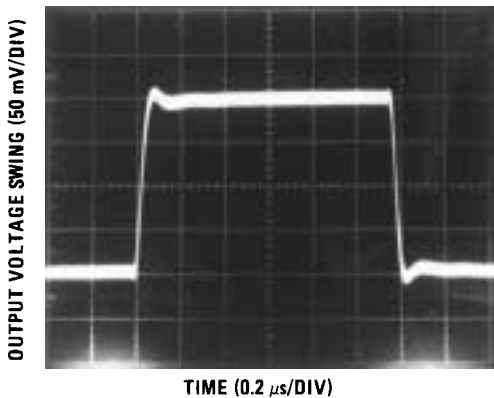

Large Signal Non-Inverting

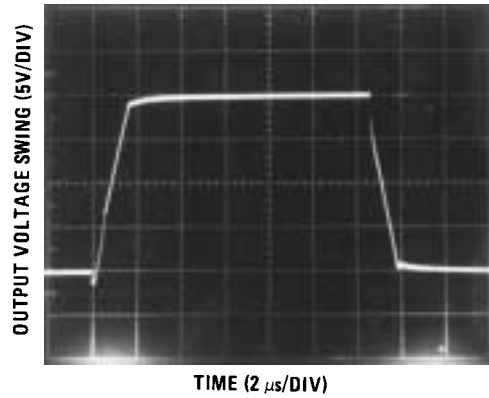

Pulse Response (Continued)

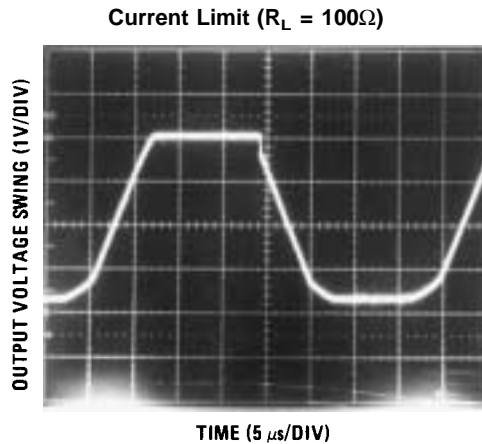

Application Hints

These devices are op amps with an internally trimmed input offset voltage and JFET input devices (BI-FET II). These JFETs have large reverse breakdown voltages from gate to source and drain eliminating the need for clamps across the inputs. Therefore, large differential input voltages can easily be accommodated without a large increase in input current. The maximum differential input voltage is independent of the supply voltages. However, neither of the input voltages should be allowed to exceed the negative supply as this will cause large currents to flow which can result in a destroyed unit.

Exceeding the negative common-mode limit on either input will force the output to a high state, potentially causing a reversal of phase to the output. Exceeding the negative common-mode limit on both inputs will force the amplifier output to a high state. In neither case does a latch occur since raising the input back within the common-mode range again puts the input stage and thus the amplifier in a normal operating mode.

Exceeding the positive common-mode limit on a single input will not change the phase of the output; however, if both inputs exceed the limit, the output of the amplifier will be forced to a high state.

The amplifiers will operate with a common-mode input voltage equal to the positive supply; however, the gain bandwidth and slew rate may be decreased in this condition. When the negative common-mode voltage swings to within 3V of the negative supply, an increase in input offset voltage may occur.

Each amplifier is individually biased by a zener reference which allows normal circuit operation on $\pm 6V$ power supplies. Supply voltages less than these may result in lower gain bandwidth and slew rate.

The amplifiers will drive a 2 k Ω load resistance to $\pm 10V$ over the full temperature range of 0°C to +70°C. If the amplifier is forced to drive heavier load currents, however, an increase in input offset voltage may occur on the negative voltage swing and finally reach an active current limit on both positive and negative swings.

Precautions should be taken to ensure that the power supply for the integrated circuit never becomes reversed in polarity or that the unit is not inadvertently installed backwards in a socket as an unlimited current surge through the resulting forward diode within the IC could cause fusing of the internal conductors and result in a destroyed unit.

As with most amplifiers, care should be taken with lead dress, component placement and supply decoupling in order to ensure stability. For example, resistors from the output to an input should be placed with the body close to the input to minimize "pick-up" and maximize the frequency of the feedback pole by minimizing the capacitance from the input to ground.

A feedback pole is created when the feedback around any amplifier is resistive. The parallel resistance and capacitance from the input of the device (usually the inverting input) to AC ground set the frequency of the pole. In many instances the frequency of this pole is much greater than the expected 3 dB frequency of the closed loop gain and consequently there is negligible effect on stability margin. However, if the feedback pole is less than approximately 6 times the expected 3 dB frequency a lead capacitor should be placed from the output to the input of the op amp. The value of the added capacitor should be such that the RC time constant of this capacitor and the resistance it parallels is greater than or equal to the original feedback pole time constant.

Detailed Schematic

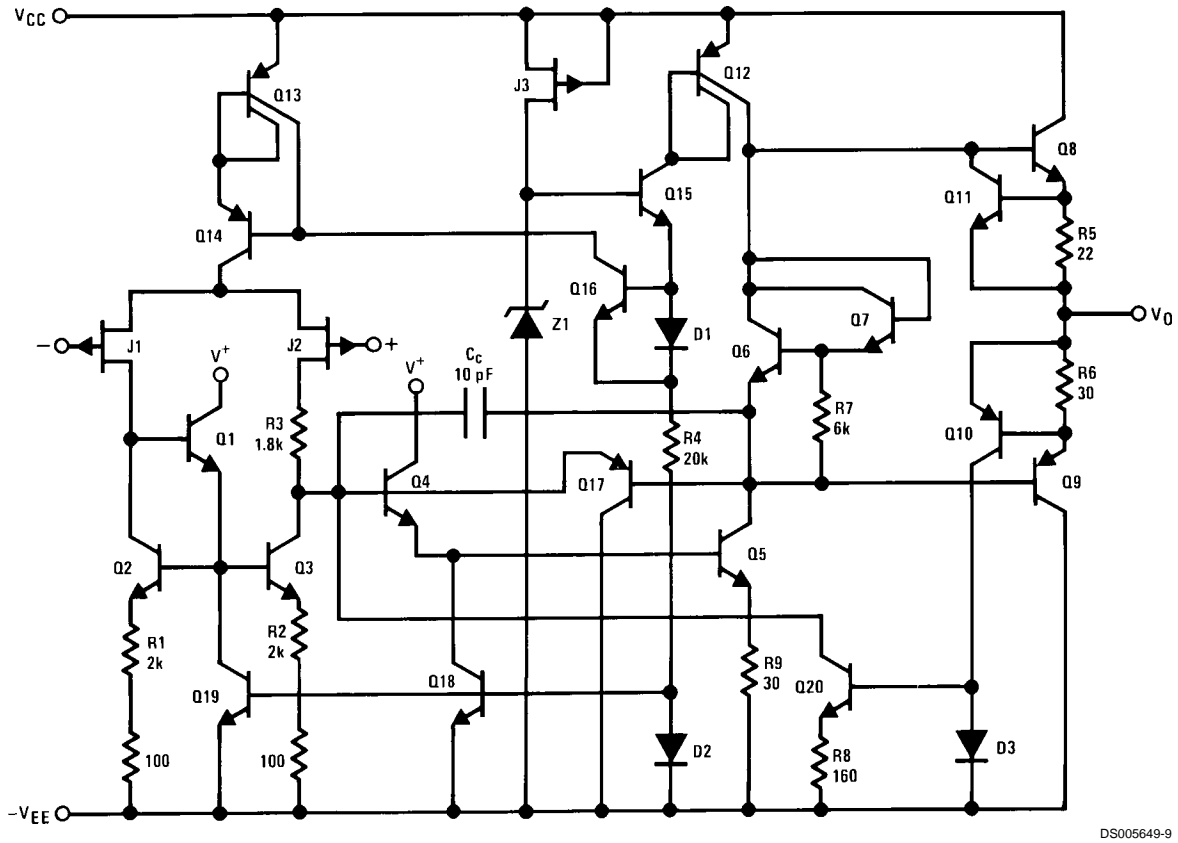

DS005649-9

Typical Applications

Three-Band Active Tone Control

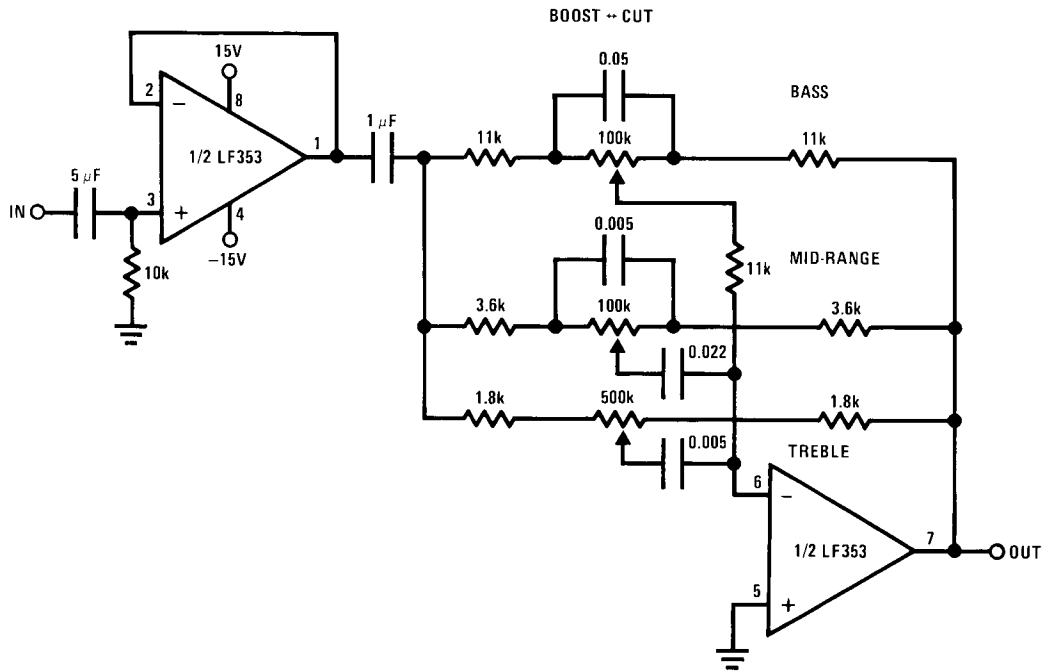

DS005649-39

Typical Applications (Continued)

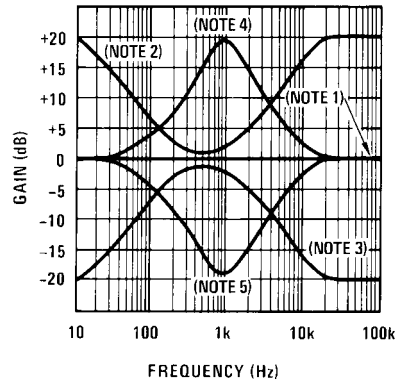

DS005649-40

Note 1: All controls flat.

Note 2: Bass and treble boost, mid flat.

Note 3: Bass and treble cut, mid flat.

Note 4: Mid boost, bass and treble flat.

Note 5: Mid cut, bass and treble flat.

- All potentiometers are linear taper
- Use the LF347 Quad for stereo applications

Improved CMRR Instrumentation Amplifier

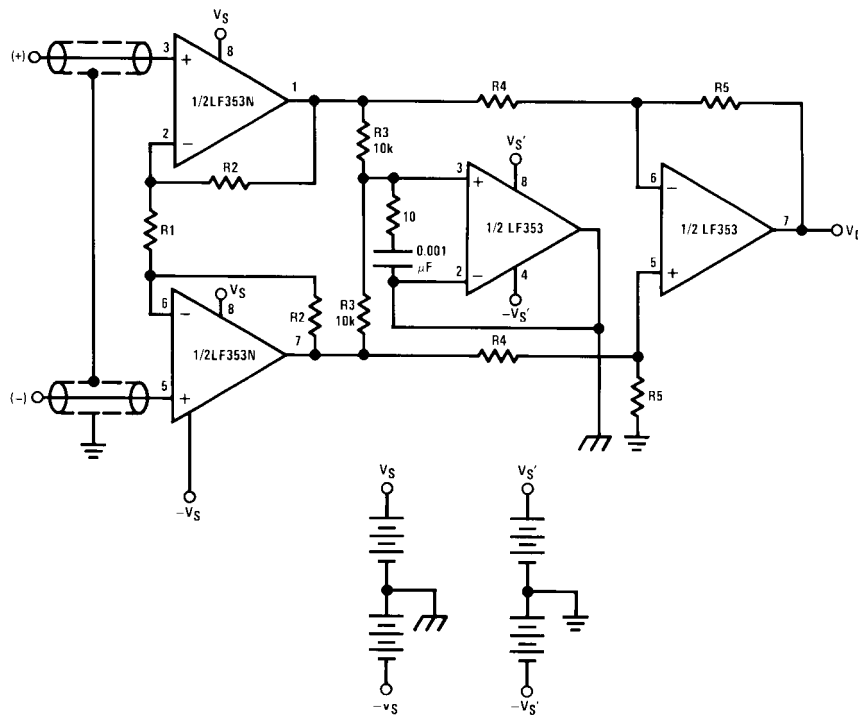

SEPARATE

DS005649-41

$$A_V = \left(\frac{2R_2}{R_1} + 1 \right) \frac{R_5}{R_4}$$

⏏ and ⏏ are separate isolated grounds

Matching of R2's, R4's and R5's control CMRR

With $A_{V_T} = 1400$, resistor matching = 0.01%: CMRR = 136 dB

- Very high input impedance
- Super high CMRR

Typical Applications (Continued)

Fourth Order Low Pass Butterworth Filter

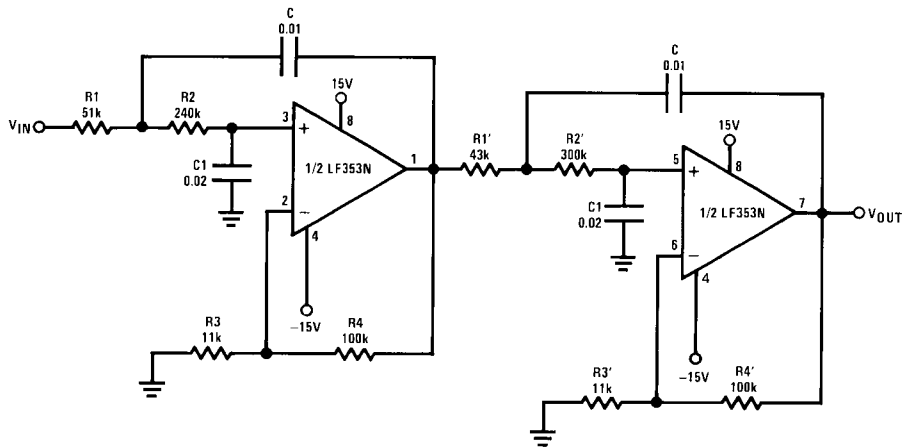

DS005649-42

- Corner frequency (f_c) = $\sqrt{\frac{1}{R1R2CC1}} \cdot \frac{1}{2\pi} = \sqrt{\frac{1}{R1'R2'CC1}} \cdot \frac{1}{2\pi}$
- Passband gain (H_0) = $(1 + R4/R3) (1 + R4'/R3')$
- First stage Q = 1.31
- Second stage Q = 0.541
- Circuit shown uses nearest 5% tolerance resistor values for a filter with a corner frequency of 100 Hz and a passband gain of 100
- Offset nulling necessary for accurate DC performance

Fourth Order High Pass Butterworth Filter

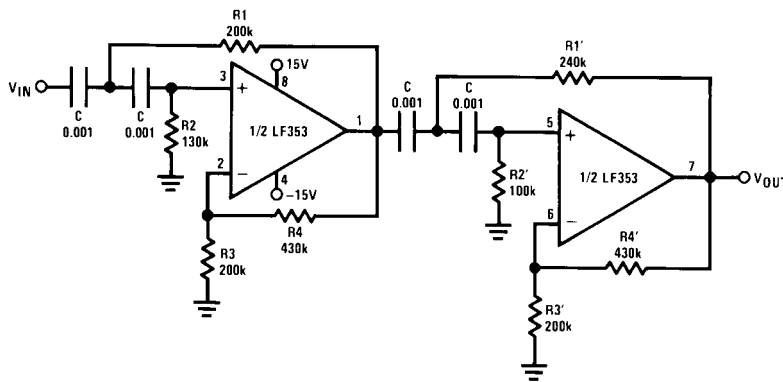

DS005649-43

- Corner frequency (f_c) = $\sqrt{\frac{1}{R1R2C^2}} \cdot \frac{1}{2\pi} = \sqrt{\frac{1}{R1'R2'C^2}} \cdot \frac{1}{2\pi}$
- Passband gain (H_0) = $(1 + R4/R3) (1 + R4'/R3')$
- First stage Q = 1.31
- Second stage Q = 0.541
- Circuit shown uses closest 5% tolerance resistor values for a filter with a corner frequency of 1 kHz and a passband gain of 10.

Typical Applications (Continued)

Ohms to Volts Converter

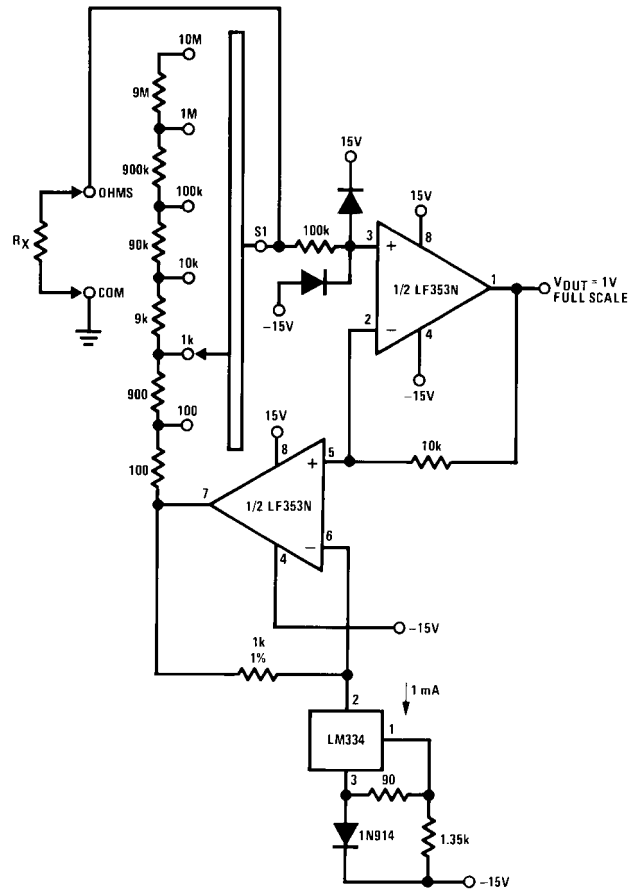

DS005649-44

$$V_O = \frac{1V}{R_{LADDER}} \times R_X$$

Where R_{LADDER} is the resistance from switch S1 pole to pin 7 of the LF353.

Physical Dimensions inches (millimeters) unless otherwise noted

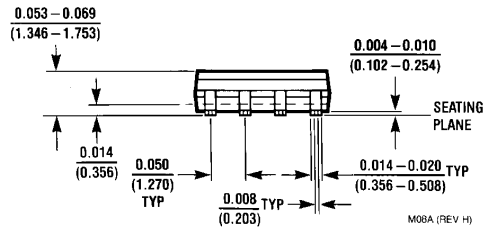
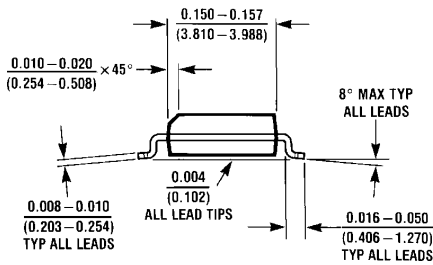
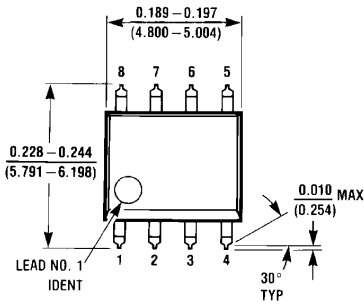

**Order Number LF353M or LF353MX
NS Package Number M08A**

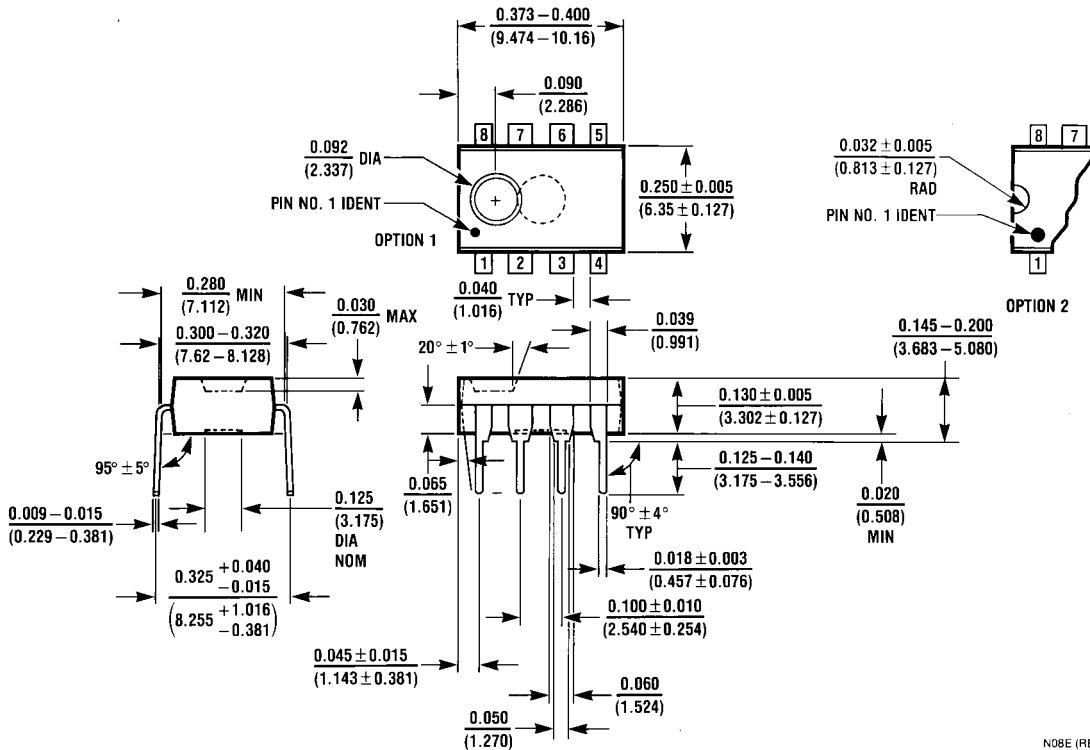

**Molded Dual-In-Line Package
Order Number LF353N
NS Package Number N08E**

Notes

LIFE SUPPORT POLICY

NATIONAL'S PRODUCTS ARE NOT AUTHORIZED FOR USE AS CRITICAL COMPONENTS IN LIFE SUPPORT DEVICES OR SYSTEMS WITHOUT THE EXPRESS WRITTEN APPROVAL OF THE PRESIDENT AND GENERAL COUNSEL OF NATIONAL SEMICONDUCTOR CORPORATION. As used herein:

1. Life support devices or systems are devices or systems which, (a) are intended for surgical implant into the body, or (b) support or sustain life, and whose failure to perform when properly used in accordance with instructions for use provided in the labeling, can be reasonably expected to result in a significant injury to the user.
2. A critical component is any component of a life support device or system whose failure to perform can be reasonably expected to cause the failure of the life support device or system, or to affect its safety or effectiveness.



National Semiconductor Corporation
Americas
Email: support@nsc.com

www.national.com

National Semiconductor Europe

Fax: +49 (0) 180-530 85 86
Email: europe.support@nsc.com
Deutsch Tel: +49 (0) 69 9508 6208
English Tel: +44 (0) 870 24 0 2171
Français Tel: +33 (0) 1 41 91 8790

National Semiconductor Asia Pacific Customer Response Group

Tel: 65-2544466
Fax: 65-2504466
Email: ap.support@nsc.com

National Semiconductor Japan Ltd.

Tel: 81-3-5639-7560
Fax: 81-3-5639-7507