

POSITIVE VOLTAGE REGULATORS

- OUTPUT CURRENT UP TO 100 mA
- OUTPUT VOLTAGES OF 3.3; 5; 6; 8; 9; 12; 15; 18; 24V
- THERMAL OVERLOAD PROTECTION
- SHORT CIRCUIT PROTECTION
- NO EXTERNAL COMPONENTS ARE REQUIRED
- AVAILABLE IN EITHER $\pm 5\%$ (AC) OR $\pm 10\%$ (C) SELECTION

DESCRIPTION

The L78L00 series of three-terminal positive regulators employ internal current limiting and thermal shutdown, making them essentially indestructible. If adequate heatsink is provided, they can deliver up to 100 mA output current. They are intended as fixed voltage regulators in a wide range of applications including local or on-card regulation for elimination of noise and distribution problems associated with single-point regulation. In addition, they can be used with power pass elements to make high-current voltage regulators.

The L78L00 series used as Zener diode/resistor combination replacement, offers an effective

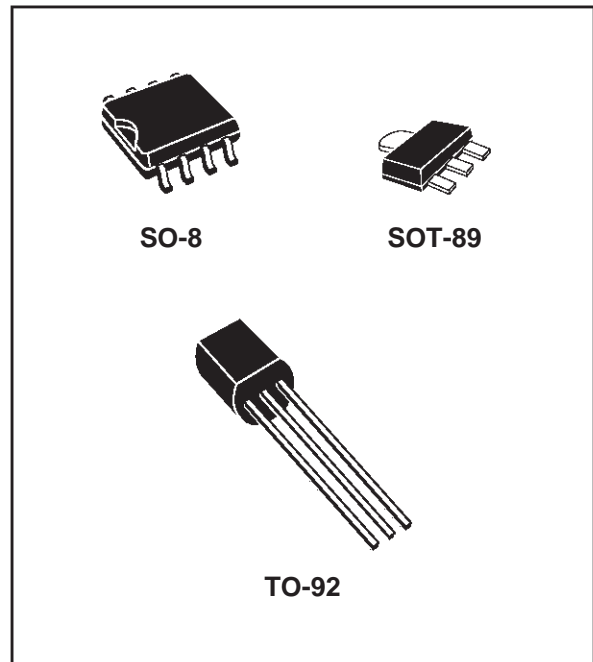

output impedance improvement of typically two orders of magnitude, along with lower quiescent current and lower noise.

BLOCK DIAGRAM

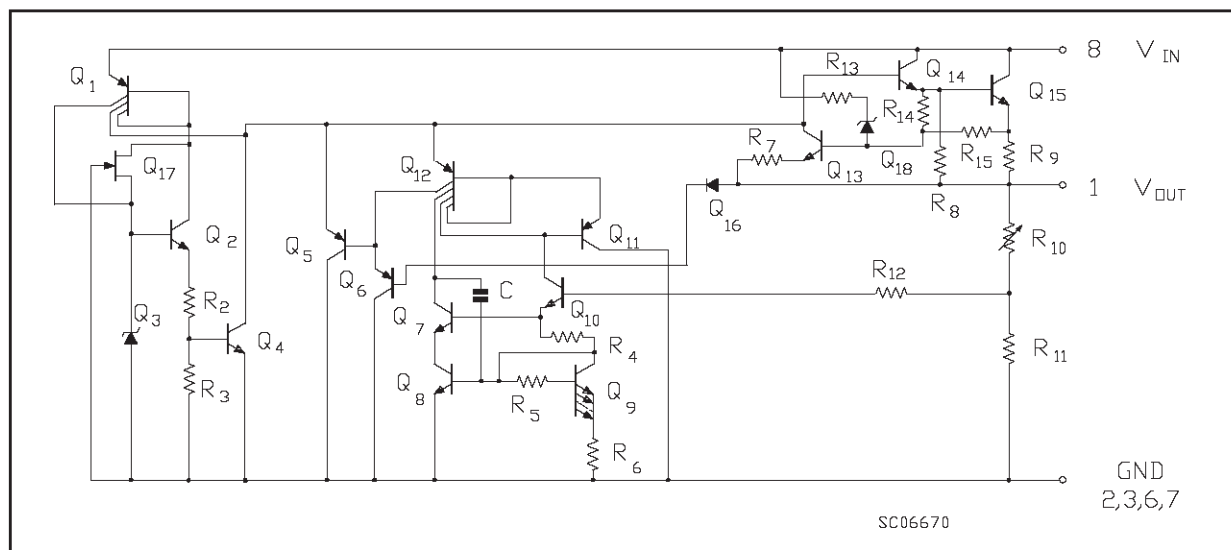

L78L00

ABSOLUTE MAXIMUM RATING

Symbol	Parameter	Value	Unit	
V_i	DC Input Voltage	$V_o = 3.3\text{ V to }9\text{ V}$	30	V
		$V_o = 12\text{ V to }15\text{ V}$	35	V
		$V_o = 18\text{ V to }24\text{ V}$	40	V
I_o	Output Current	100	mA	
P_{tot}	Power Dissipation	Internally limited (*)		
T_{stg}	Storage Temperature Range	- 40 to 150	°C	
T_{op}	Operating Junction Temperature Range For L78L00C, L78L00AC For L78L00AB	0 to 125	°C	
		- 40 to 125	°C	

(*) Our SO-8 package used for Voltage Regulators is modified internally to have pins 2, 3, 6 and 7 electrically commoned to the die attach flag. This particular frame decreases the total thermal resistance of the package and increases its ability to dissipate power when an appropriate area of copper on the printed circuit board is available for heatsinking. The external dimensions are the same as for the standard SO-8

THERMAL DATA

Symbol	Parameter		SO-8	TO-92	SOT-89	Unit
$R_{thj-case}$	Thermal Resistance Junction-case	Max	20		15	°C/W
$R_{thj-amb}$	Thermal Resistance Junction-ambient	Max	55 (*)	200		°C/W

(*) Considering 6cm² of copper Board heat-sink

TEST CIRCUITS

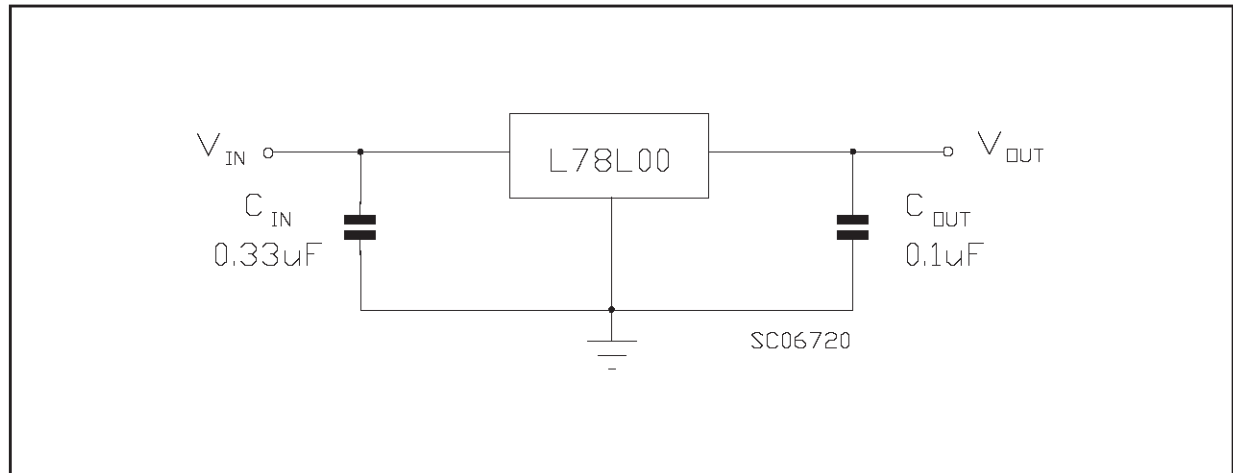

CONNECTION DIAGRAM AND ORDERING NUMBERS (top view)

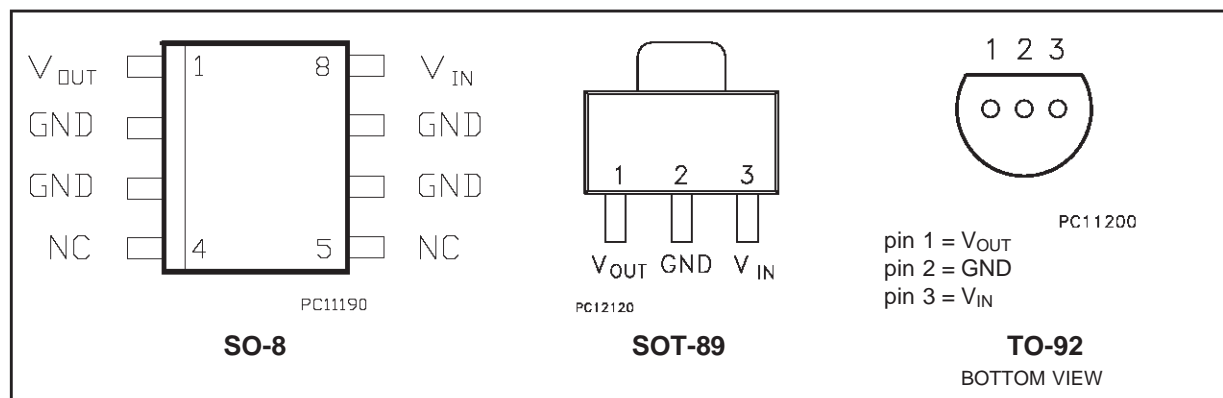

ORDERING NUMBERS

Type	SO-8	TO-92	SOT-89	Output Voltage
L78L33AC	L78L33ACD	L78L33ACZ	L78L33ACU	3.3 V
L78L33AB	L78L33ABD	L78L33ABZ	L78L33ABU	3.3 V
L78L05C	L78L05CD	L78L05CZ		5 V
L78L05AC	L78L05ACD	L78L05ACZ	L78L05ACU	5 V
L78L05AB	L78L05ABD	L78L05ABZ	L78L05ABU	5 V
L78L06C	L78L06CD	L78L06CZ		6 V
L78L06AC	L78L06ACD	L78L06ACZ	L78L06ACU	6 V
L78L06AB	L78L06ABD	L78L06ABZ	L78L06ABU	6 V
L78L08C	L78L08CD	L78L08CZ		8 V
L78L08AC	L78L08ACD	L78L08ACZ	L78L08ACU	8 V
L78L08AB	L78L08ABD	L78L08ABZ	L78L08ABU	8 V
L78L09C	L78L09CD	L78L09CZ		9 V
L78L09AC	L78L09ACD	L78L09ACZ	L78L09ACU	9 V
L78L09AB	L78L09ABD	L78L09ABZ	L78L09ABU	9 V
L78L12C	L78L12CD	L78L12CZ		12 V
L78L12AC	L78L12ACD	L78L12ACZ	L78L12ACU	12 V
L78L12AB	L78L12ABD	L78L12ABZ	L78L12ABU	12 V
L78L15C	L78L15CD	L78L15CZ		15 V
L78L15AC	L78L15ACD	L78L15ACZ	L78L15ACU	15 V
L78L15AB	L78L15ABD	L78L15ABZ	L78L15ABU	15 V
L78L18C	L78L18CD	L78L18CZ		18 V
L78L18AC	L78L18ACD	L78L18ACZ	L78L18ACU	18 V
L78L18AB	L78L18ABD	L78L18ABZ	L78L18ABU	18 V
L78L24C	L78L24CD	L78L24CZ		24 V
L78L24AC	L78L24ACD	L78L24ACZ	L78L24ACU	24 V
L78L24AB	L78L24ABD	L78L24ABZ	L78L24ABU	24 V

L78L00

ELECTRICAL CHARACTERISTICS FOR L78L05 (refer to the test circuits, $T_j = 0$ to 125 °C, $V_i = 10$ V, $I_o = 40$ mA, $C_i = 0.33$ μ F, $C_o = 0.1$ μ F unless otherwise specified)

Symbol	Parameter	Test Conditions	Min.	Typ.	Max.	Unit
V_o	Output Voltage	$T_j = 25$ °C	4.6	5	5.4	V
V_o	Output Voltage	$I_o = 1$ to 40 mA $V_i = 7$ to 20 V $I_o = 1$ to 70 mA $V_i = 10$ V	4.5 4.5		5.5 5.5	V V
ΔV_o	Line Regulation	$V_i = 7$ to 20 V $T_j = 25$ °C $V_i = 8$ to 20 V $T_j = 25$ °C			200 150	mV mV
ΔV_o	Load Regulation	$I_o = 1$ to 100 mA $T_j = 25$ °C $I_o = 1$ to 40 mA $T_j = 25$ °C			60 30	mV mV
I_d	Quiescent Current	$T_j = 25$ °C $T_j = 125$ °C			6 5.5	mA mA
ΔI_d	Quiescent Current Change	$I_o = 1$ to 40 mA			0.2	mA
ΔI_d	Quiescent Current Change	$V_i = 8$ to 20 V			1.5	mA
eN	Output Noise Voltage	$B = 10$ Hz to 100 KHz $T_j = 25$ °C		40		μ V
SVR	Supply Voltage Rejection	$I_o = 40$ mA $f = 120$ Hz $T_j = 25$ °C $V_i = 8$ to 18 V	40	49		dB
V_d	Dropout Voltage			1.7		V

ELECTRICAL CHARACTERISTICS FOR L78L06 (refer to the test circuits, $T_j = 0$ to 125 °C, $V_i = 12$ V, $I_o = 40$ mA, $C_i = 0.33$ μ F, $C_o = 0.1$ μ F unless otherwise specified)

Symbol	Parameter	Test Conditions	Min.	Typ.	Max.	Unit
V_o	Output Voltage	$T_j = 25$ °C	5.52	6	6.48	V
V_o	Output Voltage	$I_o = 1$ to 40 mA $V_i = 8.5$ to 20 V $I_o = 1$ to 70 mA $V_i = 12$ V	5.4 5.4		6.6 6.6	V V
ΔV_o	Line Regulation	$V_i = 8.5$ to 20 V $T_j = 25$ °C $V_i = 9$ to 20 V $T_j = 25$ °C			200 150	mV mV
ΔV_o	Load Regulation	$I_o = 1$ to 100 mA $T_j = 25$ °C $I_o = 1$ to 40 mA $T_j = 25$ °C			60 30	mV mV
I_d	Quiescent Current	$T_j = 25$ °C $T_j = 125$ °C			6 5.5	mA mA
ΔI_d	Quiescent Current Change	$I_o = 1$ to 40 mA			0.2	mA
ΔI_d	Quiescent Current Change	$V_i = 8$ to 20 V			1.5	mA
eN	Output Noise Voltage	$B = 10$ Hz to 100 KHz $T_j = 25$ °C		50		μ V
SVR	Supply Voltage Rejection	$I_o = 40$ mA $f = 120$ Hz $T_j = 25$ °C $V_i = 9$ to 20 V	38	46		dB
V_d	Dropout Voltage			1.7		V

ELECTRICAL CHARACTERISTICS FOR L78L08 (refer to the test circuits, $T_j = 0$ to 125 °C, $V_i = 14$ V, $I_o = 40$ mA, $C_i = 0.33$ μ F, $C_o = 0.1$ μ F unless otherwise specified)

Symbol	Parameter	Test Conditions	Min.	Typ.	Max.	Unit
V_o	Output Voltage	$T_j = 25$ °C	7.36	8	8.64	V
V_o	Output Voltage	$I_o = 1$ to 40 mA $V_i = 10.5$ to 23 V $I_o = 1$ to 70 mA $V_i = 14$ V	7.2 7.2		8.8 8.8	V V
ΔV_o	Line Regulation	$V_i = 10.5$ to 23 V $T_j = 25$ °C $V_i = 11$ to 23 V $T_j = 25$ °C			200 150	mV mV
ΔV_o	Load Regulation	$I_o = 1$ to 100 mA $T_j = 25$ °C $I_o = 1$ to 40 mA $T_j = 25$ °C			80 40	mV mV
I_d	Quiescent Current	$T_j = 25$ °C $T_j = 125$ °C			6 5.5	mA mA
ΔI_d	Quiescent Current Change	$I_o = 1$ to 40 mA			0.2	mA
ΔI_d	Quiescent Current Change	$V_i = 11$ to 23 V			1.5	mA
eN	Output Noise Voltage	$B = 10$ Hz to 100 KHz $T_j = 25$ °C		60		μ V
SVR	Supply Voltage Rejection	$I_o = 40$ mA $f = 120$ Hz $T_j = 25$ °C $V_i = 12$ to 23 V	36	45		dB
V_d	Dropout Voltage			1.7		V

ELECTRICAL CHARACTERISTICS FOR L78L09 (refer to the test circuits, $T_j = 0$ to 125 °C, $V_i = 15$ V, $I_o = 40$ mA, $C_i = 0.33$ μ F, $C_o = 0.1$ μ F unless otherwise specified)

Symbol	Parameter	Test Conditions	Min.	Typ.	Max.	Unit
V_o	Output Voltage	$T_j = 25$ °C	8.28	9	9.72	V
V_o	Output Voltage	$I_o = 1$ to 40 mA $V_i = 11.5$ to 23 V $I_o = 1$ to 70 mA $V_i = 15$ V	8.1 8.1		9.9 9.9	V V
ΔV_o	Line Regulation	$V_i = 11.5$ to 23 V $T_j = 25$ °C $V_i = 12$ to 23 V $T_j = 25$ °C			250 200	mV mV
ΔV_o	Load Regulation	$I_o = 1$ to 100 mA $T_j = 25$ °C $I_o = 1$ to 40 mA $T_j = 25$ °C			80 40	mV mV
I_d	Quiescent Current	$T_j = 25$ °C $T_j = 125$ °C			6 5.5	mA mA
ΔI_d	Quiescent Current Change	$I_o = 1$ to 40 mA			0.2	mA
ΔI_d	Quiescent Current Change	$V_i = 12$ to 23 V			1.5	mA
eN	Output Noise Voltage	$B = 10$ Hz to 100 KHz $T_j = 25$ °C		70		μ V
SVR	Supply Voltage Rejection	$I_o = 40$ mA $f = 120$ Hz $T_j = 25$ °C $V_i = 12$ to 23 V	36	44		dB
V_d	Dropout Voltage			1.7		V

ELECTRICAL CHARACTERISTICS FOR L78L12 (refer to the test circuits, $T_j = 0$ to $125\text{ }^\circ\text{C}$,
 $V_i = 19\text{ V}$, $I_o = 40\text{ mA}$, $C_i = 0.33\text{ }\mu\text{F}$, $C_o = 0.1\text{ }\mu\text{F}$ unless otherwise specified)

Symbol	Parameter	Test Conditions	Min.	Typ.	Max.	Unit
V_o	Output Voltage	$T_j = 25\text{ }^\circ\text{C}$	11.1	12	12.9	V
V_o	Output Voltage	$I_o = 1$ to 40 mA $V_i = 14.5$ to 27 V $I_o = 1$ to 70 mA $V_i = 19\text{ V}$	10.8 10.8		13.2 13.2	V V
ΔV_o	Line Regulation	$V_i = 14.5$ to 27 V $T_j = 25\text{ }^\circ\text{C}$ $V_i = 16$ to 27 V $T_j = 25\text{ }^\circ\text{C}$			250 200	mV mV
ΔV_o	Load Regulation	$I_o = 1$ to 100 mA $T_j = 25\text{ }^\circ\text{C}$ $I_o = 1$ to 40 mA $T_j = 25\text{ }^\circ\text{C}$			100 50	mV mV
I_d	Quiescent Current	$T_j = 25\text{ }^\circ\text{C}$ $T_j = 125\text{ }^\circ\text{C}$			6.5 6	mA mA
ΔI_d	Quiescent Current Change	$I_o = 1$ to 40 mA			0.2	mA
ΔI_d	Quiescent Current Change	$V_i = 16$ to 27 V			1.5	mA
eN	Output Noise Voltage	$B = 10\text{ Hz}$ to 100 kHz $T_j = 25\text{ }^\circ\text{C}$		80		μV
SVR	Supply Voltage Rejection	$I_o = 40\text{ mA}$ $f = 120\text{ Hz}$ $T_j = 25\text{ }^\circ\text{C}$ $V_i = 15$ to 25 V	36	42		dB
V_d	Dropout Voltage			1.7		V

ELECTRICAL CHARACTERISTICS FOR L78L15 (refer to the test circuits, $T_j = 0$ to $125\text{ }^\circ\text{C}$,
 $V_i = 23\text{ V}$, $I_o = 40\text{ mA}$, $C_i = 0.33\text{ }\mu\text{F}$, $C_o = 0.1\text{ }\mu\text{F}$ unless otherwise specified)

Symbol	Parameter	Test Conditions	Min.	Typ.	Max.	Unit
V_o	Output Voltage	$T_j = 25\text{ }^\circ\text{C}$	13.8	15	16.2	V
V_o	Output Voltage	$I_o = 1$ to 40 mA $V_i = 17.5$ to 30 V $I_o = 1$ to 70 mA $V_i = 23\text{ V}$	13.5 13.5		16.5 16.5	V V
ΔV_o	Line Regulation	$V_i = 17.5$ to 30 V $T_j = 25\text{ }^\circ\text{C}$ $V_i = 20$ to 30 V $T_j = 25\text{ }^\circ\text{C}$			300 250	mV mV
ΔV_o	Load Regulation	$I_o = 1$ to 100 mA $T_j = 25\text{ }^\circ\text{C}$ $I_o = 1$ to 40 mA $T_j = 25\text{ }^\circ\text{C}$			150 75	mV mV
I_d	Quiescent Current	$T_j = 25\text{ }^\circ\text{C}$ $T_j = 125\text{ }^\circ\text{C}$			6.5 6	mA mA
ΔI_d	Quiescent Current Change	$I_o = 1$ to 40 mA			0.2	mA
ΔI_d	Quiescent Current Change	$V_i = 20$ to 30 V			1.5	mA
eN	Output Noise Voltage	$B = 10\text{ Hz}$ to 100 kHz $T_j = 25\text{ }^\circ\text{C}$		90		μV
SVR	Supply Voltage Rejection	$I_o = 40\text{ mA}$ $f = 120\text{ Hz}$ $T_j = 25\text{ }^\circ\text{C}$ $V_i = 18.5$ to 28.5 V	33	39		dB
V_d	Dropout Voltage			1.7		V

ELECTRICAL CHARACTERISTICS FOR L78L18 (refer to the test circuits, $T_j = 0$ to 125 °C, $V_i = 27$ V, $I_o = 40$ mA, $C_i = 0.33$ μ F, $C_o = 0.1$ μ F unless otherwise specified)

Symbol	Parameter	Test Conditions	Min.	Typ.	Max.	Unit
V_o	Output Voltage	$T_j = 25$ °C	16.6	18	19.4	V
V_o	Output Voltage	$I_o = 1$ to 40 mA $V_i = 22$ to 33 V $I_o = 1$ to 70 mA $V_i = 27$ V	16.2 16.2		19.8 19.8	V V
ΔV_o	Line Regulation	$V_i = 22$ to 33 V $T_j = 25$ °C $V_i = 22$ to 33 V $T_j = 25$ °C			320 270	mV mV
ΔV_o	Load Regulation	$I_o = 1$ to 100 mA $T_j = 25$ °C $I_o = 1$ to 40 mA $T_j = 25$ °C			170 85	mV mV
I_d	Quiescent Current	$T_j = 25$ °C $T_j = 125$ °C			6.5 6	mA mA
ΔI_d	Quiescent Current Change	$I_o = 1$ to 40 mA			0.2	mA
ΔI_d	Quiescent Current Change	$V_i = 23$ to 33 V			1.5	mA
eN	Output Noise Voltage	$B = 10$ Hz to 100 KHz $T_j = 25$ °C		120		μ V
SVR	Supply Voltage Rejection	$I_o = 40$ mA $f = 120$ Hz $T_j = 25$ °C $V_i = 23$ to 33 V	32	38		dB
V_d	Dropout Voltage			1.7		V

ELECTRICAL CHARACTERISTICS FOR L78L24 (refer to the test circuits, $T_j = 0$ to 125 °C, $V_i = 33$ V, $I_o = 40$ mA, $C_i = 0.33$ μ F, $C_o = 0.1$ μ F unless otherwise specified)

Symbol	Parameter	Test Conditions	Min.	Typ.	Max.	Unit
V_o	Output Voltage	$T_j = 25$ °C	22.1	24	25.9	V
V_o	Output Voltage	$I_o = 1$ to 40 mA $V_i = 27$ to 38 V $I_o = 1$ to 70 mA $V_i = 33$ V	21.6 21.6		26.4 26.4	V V
ΔV_o	Line Regulation	$V_i = 27$ to 38 V $T_j = 25$ °C $V_i = 28$ to 38 V $T_j = 25$ °C			350 300	mV mV
ΔV_o	Load Regulation	$I_o = 1$ to 100 mA $T_j = 25$ °C $I_o = 1$ to 40 mA $T_j = 25$ °C			200 100	mV mV
I_d	Quiescent Current	$T_j = 25$ °C $T_j = 125$ °C			6.5 6	mA mA
ΔI_d	Quiescent Current Change	$I_o = 1$ to 40 mA			0.2	mA
ΔI_d	Quiescent Current Change	$V_i = 28$ to 38 V			1.5	mA
eN	Output Noise Voltage	$B = 10$ Hz to 100 KHz $T_j = 25$ °C		200		μ V
SVR	Supply Voltage Rejection	$I_o = 40$ mA $f = 120$ Hz $T_j = 25$ °C $V_i = 29$ to 35 V	30	37		dB
V_d	Dropout Voltage			1.7		V

ELECTRICAL CHARACTERISTICS FOR L78L33AB AND L78L33AC(refer to the test circuits, $V_i = 8.3V$, $I_o = 40\text{ mA}$, $C_i = 0.33\text{ }\mu\text{F}$, $C_o = 0.1\text{ }\mu\text{F}$, $T_j = 0\text{ to }125\text{ }^\circ\text{C}$ for L78L33AC, $T_j = -40\text{ to }125\text{ }^\circ\text{C}$ for L78L33AB, unless otherwise specified)

Symbol	Parameter	Test Conditions	Min.	Typ.	Max.	Unit
V_o	Output Voltage	$T_j = 25\text{ }^\circ\text{C}$	3.168	3.3	3.432	V
V_o	Output Voltage	$I_o = 1\text{ to }40\text{ mA}$ $V_i = 5.3\text{ to }20\text{ V}$ $I_o = 1\text{ to }70\text{ mA}$ $V_i = 8.3\text{ V}$	3.135 3.135		3.465 3.465	V V
ΔV_o	Line Regulation	$V_i = 5.3\text{ to }20\text{ V}$ $T_j = 25\text{ }^\circ\text{C}$ $V_i = 6.3\text{ to }20\text{ V}$ $T_j = 25\text{ }^\circ\text{C}$			150 100	mV mV
ΔV_o	Load Regulation	$I_o = 1\text{ to }100\text{ mA}$ $T_j = 25\text{ }^\circ\text{C}$ $I_o = 1\text{ to }40\text{ mA}$ $T_j = 25\text{ }^\circ\text{C}$			60 30	mV mV
I_d	Quiescent Current	$T_j = 25\text{ }^\circ\text{C}$ $T_j = 125\text{ }^\circ\text{C}$			6 5.5	mA mA
ΔI_d	Quiescent Current Change	$I_o = 1\text{ to }40\text{ mA}$			0.1	mA
ΔI_d	Quiescent Current Change	$V_i = 6.3\text{ to }20\text{ V}$			1.5	mA
eN	Output Noise Voltage	$B = 10\text{Hz to }100\text{kHz}$ $T_j = 25\text{ }^\circ\text{C}$		40		μV
SVR	Supply Voltage Rejection	$I_o = 40\text{ mA}$ $f = 120\text{ Hz}$ $T_j = 25\text{ }^\circ\text{C}$ $V_i = 6.3\text{ to }16.3\text{ V}$	41	49		dB
V_d	Dropout Voltage			1.7		V

ELECTRICAL CHARACTERISTICS FOR L78L05AB AND L78L05AC(refer to the test circuits, $V_i = 10V$, $I_o = 40\text{ mA}$, $C_i = 0.33\text{ }\mu\text{F}$, $C_o = 0.1\text{ }\mu\text{F}$, $T_j = 0\text{ to }125\text{ }^\circ\text{C}$ for L78L05AC, $T_j = -40\text{ to }125\text{ }^\circ\text{C}$ for L78L05AB, unless otherwise specified)

Symbol	Parameter	Test Conditions	Min.	Typ.	Max.	Unit
V_o	Output Voltage	$T_j = 25\text{ }^\circ\text{C}$	4.8	5	5.2	V
V_o	Output Voltage	$I_o = 1\text{ to }40\text{ mA}$ $V_i = 7\text{ to }20\text{ V}$ $I_o = 1\text{ to }70\text{ mA}$ $V_i = 10\text{ V}$	4.75 4.75		5.25 5.25	V V
ΔV_o	Line Regulation	$V_i = 7\text{ to }20\text{ V}$ $T_j = 25\text{ }^\circ\text{C}$ $V_i = 8\text{ to }20\text{ V}$ $T_j = 25\text{ }^\circ\text{C}$			150 100	mV mV
ΔV_o	Load Regulation	$I_o = 1\text{ to }100\text{ mA}$ $T_j = 25\text{ }^\circ\text{C}$ $I_o = 1\text{ to }40\text{ mA}$ $T_j = 25\text{ }^\circ\text{C}$			60 30	mV mV
I_d	Quiescent Current	$T_j = 25\text{ }^\circ\text{C}$ $T_j = 125\text{ }^\circ\text{C}$			6 5.5	mA mA
ΔI_d	Quiescent Current Change	$I_o = 1\text{ to }40\text{ mA}$			0.1	mA
ΔI_d	Quiescent Current Change	$V_i = 8\text{ to }20\text{ V}$			1.5	mA
eN	Output Noise Voltage	$B = 10\text{Hz to }100\text{kHz}$ $T_j = 25\text{ }^\circ\text{C}$		40		μV
SVR	Supply Voltage Rejection	$I_o = 40\text{ mA}$ $f = 120\text{ Hz}$ $T_j = 25\text{ }^\circ\text{C}$ $V_i = 8\text{ to }18\text{ V}$	41	49		dB
V_d	Dropout Voltage			1.7		V

ELECTRICAL CHARACTERISTICS FOR L78L06AB AND L78L06AC(refer to the test circuits, $V_i = 12\text{V}$, $I_o = 40\text{ mA}$, $C_i = 0.33\text{ }\mu\text{F}$, $C_o = 0.1\text{ }\mu\text{F}$, $T_j = 0\text{ to }125\text{ }^\circ\text{C}$ for L78L06AC, $T_j = -40\text{ to }125\text{ }^\circ\text{C}$ for L78L06AB, unless otherwise specified)

Symbol	Parameter	Test Conditions	Min.	Typ.	Max.	Unit
V_o	Output Voltage	$T_j = 25\text{ }^\circ\text{C}$	5.76	6	6.24	V
V_o	Output Voltage	$I_o = 1\text{ to }40\text{ mA}$ $V_i = 8.5\text{ to }20\text{ V}$ $I_o = 1\text{ to }70\text{ mA}$ $V_i = 12\text{ V}$	5.7 5.7		6.3 6.3	V V
ΔV_o	Line Regulation	$V_i = 8.5\text{ to }20\text{ V}$ $T_j = 25\text{ }^\circ\text{C}$ $V_i = 9\text{ to }20\text{ V}$ $T_j = 25\text{ }^\circ\text{C}$			150 100	mV mV
ΔV_o	Load Regulation	$I_o = 1\text{ to }100\text{ mA}$ $T_j = 25\text{ }^\circ\text{C}$ $I_o = 1\text{ to }40\text{ mA}$ $T_j = 25\text{ }^\circ\text{C}$			60 30	mV mV
I_d	Quiescent Current	$T_j = 25\text{ }^\circ\text{C}$ $T_j = 125\text{ }^\circ\text{C}$			6 5.5	mA mA
ΔI_d	Quiescent Current Change	$I_o = 1\text{ to }40\text{ mA}$			0.1	mA
ΔI_d	Quiescent Current Change	$V_i = 9\text{ to }20\text{ V}$			1.5	mA
eN	Output Noise Voltage	$B = 10\text{Hz to }100\text{kHz}$ $T_j = 25\text{ }^\circ\text{C}$		50		μV
SVR	Supply Voltage Rejection	$I_o = 40\text{ mA}$ $f = 120\text{ Hz}$ $T_j = 25\text{ }^\circ\text{C}$ $V_i = 9\text{ to }20\text{ V}$	39	46		dB
V_d	Dropout Voltage			1.7		V

ELECTRICAL CHARACTERISTICS FOR L78L08AB AND L78L08AC(refer to the test circuits, $V_i = 14\text{V}$, $I_o = 40\text{ mA}$, $C_i = 0.33\text{ }\mu\text{F}$, $C_o = 0.1\text{ }\mu\text{F}$, $T_j = 0\text{ to }125\text{ }^\circ\text{C}$ for L78L08AC, $T_j = -40\text{ to }125\text{ }^\circ\text{C}$ for L78L08AB, unless otherwise specified)

Symbol	Parameter	Test Conditions	Min.	Typ.	Max.	Unit
V_o	Output Voltage	$T_j = 25\text{ }^\circ\text{C}$	7.68	8	8.32	V
V_o	Output Voltage	$I_o = 1\text{ to }40\text{ mA}$ $V_i = 10.5\text{ to }23\text{ V}$ $I_o = 1\text{ to }70\text{ mA}$ $V_i = 14\text{ V}$	7.6 7.6		8.4 8.4	V V
ΔV_o	Line Regulation	$V_i = 10.5\text{ to }23\text{ V}$ $T_j = 25\text{ }^\circ\text{C}$ $V_i = 11\text{ to }23\text{ V}$ $T_j = 25\text{ }^\circ\text{C}$			175 125	mV mV
ΔV_o	Load Regulation	$I_o = 1\text{ to }100\text{ mA}$ $T_j = 25\text{ }^\circ\text{C}$ $I_o = 1\text{ to }40\text{ mA}$ $T_j = 25\text{ }^\circ\text{C}$			80 40	mV mV
I_d	Quiescent Current	$T_j = 25\text{ }^\circ\text{C}$ $T_j = 125\text{ }^\circ\text{C}$			6 5.5	mA mA
ΔI_d	Quiescent Current Change	$I_o = 1\text{ to }40\text{ mA}$			0.1	mA
ΔI_d	Quiescent Current Change	$V_i = 11\text{ to }23\text{ V}$			1.5	mA
eN	Output Noise Voltage	$B = 10\text{Hz to }100\text{kHz}$ $T_j = 25\text{ }^\circ\text{C}$		60		μV
SVR	Supply Voltage Rejection	$I_o = 40\text{ mA}$ $f = 120\text{ Hz}$ $T_j = 25\text{ }^\circ\text{C}$ $V_i = 12\text{ to }23\text{ V}$	37	45		dB
V_d	Dropout Voltage			1.7		V

ELECTRICAL CHARACTERISTICS FOR L78L09AB AND L78L09AC(refer to the test circuits, $V_i = 15V$, $I_o = 40\text{ mA}$, $C_i = 0.33\text{ }\mu\text{F}$, $C_o = 0.1\text{ }\mu\text{F}$, $T_j = 0\text{ to }125\text{ }^\circ\text{C}$ for L78L09AC, $T_j = -40\text{ to }125\text{ }^\circ\text{C}$ for L78L09AB, unless otherwise specified)

Symbol	Parameter	Test Conditions	Min.	Typ.	Max.	Unit
V_o	Output Voltage	$T_j = 25\text{ }^\circ\text{C}$	8.64	9	9.36	V
V_o	Output Voltage	$I_o = 1\text{ to }40\text{ mA}$ $V_i = 11.5\text{ to }23\text{ V}$ $I_o = 1\text{ to }70\text{ mA}$ $V_i = 15\text{ V}$	8.55 8.55		9.45 9.45	V V
ΔV_o	Line Regulation	$V_i = 11.5\text{ to }23\text{ V}$ $T_j = 25\text{ }^\circ\text{C}$ $V_i = 12\text{ to }23\text{ V}$ $T_j = 25\text{ }^\circ\text{C}$			225 150	mV mV
ΔV_o	Load Regulation	$I_o = 1\text{ to }100\text{ mA}$ $T_j = 25\text{ }^\circ\text{C}$ $I_o = 1\text{ to }40\text{ mA}$ $T_j = 25\text{ }^\circ\text{C}$			80 40	mV mV
I_d	Quiescent Current	$T_j = 25\text{ }^\circ\text{C}$ $T_j = 125\text{ }^\circ\text{C}$			6 5.5	mA mA
ΔI_d	Quiescent Current Change	$I_o = 1\text{ to }40\text{ mA}$			0.1	mA
ΔI_d	Quiescent Current Change	$V_i = 12\text{ to }23\text{ V}$			1.5	mA
eN	Output Noise Voltage	$B = 10\text{Hz to }100\text{kHz}$ $T_j = 25\text{ }^\circ\text{C}$		70		μV
SVR	Supply Voltage Rejection	$I_o = 40\text{ mA}$ $f = 120\text{ Hz}$ $T_j = 25\text{ }^\circ\text{C}$ $V_i = 12\text{ to }23\text{ V}$	37	44		dB
V_d	Dropout Voltage			1.7		V

ELECTRICAL CHARACTERISTICS FOR L78L12AB AND L78L12AC(refer to the test circuits, $V_i = 19V$, $I_o = 40\text{ mA}$, $C_i = 0.33\text{ }\mu\text{F}$, $C_o = 0.1\text{ }\mu\text{F}$, $T_j = 0\text{ to }125\text{ }^\circ\text{C}$ for L78L12AC, $T_j = -40\text{ to }125\text{ }^\circ\text{C}$ for L78L12AB, unless otherwise specified)

Symbol	Parameter	Test Conditions	Min.	Typ.	Max.	Unit
V_o	Output Voltage	$T_j = 25\text{ }^\circ\text{C}$	11.5	12	12.5	V
V_o	Output Voltage	$I_o = 1\text{ to }40\text{ mA}$ $V_i = 14.5\text{ to }27\text{ V}$ $I_o = 1\text{ to }70\text{ mA}$ $V_i = 19\text{ V}$	11.4 11.4		12.6 12.6	V V
ΔV_o	Line Regulation	$V_i = 14.5\text{ to }27\text{ V}$ $T_j = 25\text{ }^\circ\text{C}$ $V_i = 16\text{ to }27\text{ V}$ $T_j = 25\text{ }^\circ\text{C}$			250 200	mV mV
ΔV_o	Load Regulation	$I_o = 1\text{ to }100\text{ mA}$ $T_j = 25\text{ }^\circ\text{C}$ $I_o = 1\text{ to }40\text{ mA}$ $T_j = 25\text{ }^\circ\text{C}$			100 50	mV mV
I_d	Quiescent Current	$T_j = 25\text{ }^\circ\text{C}$ $T_j = 125\text{ }^\circ\text{C}$			6.5 6	mA mA
ΔI_d	Quiescent Current Change	$I_o = 1\text{ to }40\text{ mA}$			0.1	mA
ΔI_d	Quiescent Current Change	$V_i = 16\text{ to }27\text{ V}$			1.5	mA
eN	Output Noise Voltage	$B = 10\text{Hz to }100\text{kHz}$ $T_j = 25\text{ }^\circ\text{C}$		80		μV
SVR	Supply Voltage Rejection	$I_o = 40\text{ mA}$ $f = 120\text{ Hz}$ $T_j = 25\text{ }^\circ\text{C}$ $V_i = 15\text{ to }25\text{ V}$	37	42		dB
V_d	Dropout Voltage			1.7		V

ELECTRICAL CHARACTERISTICS FOR L78L15AB AND L78L15AC(refer to the test circuits, $V_i = 23\text{V}$, $I_o = 40\text{ mA}$, $C_i = 0.33\text{ }\mu\text{F}$, $C_o = 0.1\text{ }\mu\text{F}$, $T_j = 0\text{ to }125\text{ }^\circ\text{C}$ for L78L15AC, $T_j = -40\text{ to }125\text{ }^\circ\text{C}$ for L78L15AB, unless otherwise specified)

Symbol	Parameter	Test Conditions	Min.	Typ.	Max.	Unit
V_o	Output Voltage	$T_j = 25\text{ }^\circ\text{C}$	14.4	15	15.6	V
V_o	Output Voltage	$I_o = 1\text{ to }40\text{ mA}$ $V_i = 17.5\text{ to }30\text{ V}$ $I_o = 1\text{ to }70\text{ mA}$ $V_i = 23\text{ V}$	14.25 14.25		15.75 15.75	V V
ΔV_o	Line Regulation	$V_i = 17.5\text{ to }30\text{ V}$ $T_j = 25\text{ }^\circ\text{C}$ $V_i = 20\text{ to }30\text{ V}$ $T_j = 25\text{ }^\circ\text{C}$			300 250	mV mV
ΔV_o	Load Regulation	$I_o = 1\text{ to }100\text{ mA}$ $T_j = 25\text{ }^\circ\text{C}$ $I_o = 1\text{ to }40\text{ mA}$ $T_j = 25\text{ }^\circ\text{C}$			150 75	mV mV
I_d	Quiescent Current	$T_j = 25\text{ }^\circ\text{C}$ $T_j = 125\text{ }^\circ\text{C}$			6.5 6	mA mA
ΔI_d	Quiescent Current Change	$I_o = 1\text{ to }40\text{ mA}$			0.1	mA
ΔI_d	Quiescent Current Change	$V_i = 20\text{ to }30\text{ V}$			1.5	mA
eN	Output Noise Voltage	$B = 10\text{Hz to }100\text{kHz}$ $T_j = 25\text{ }^\circ\text{C}$		90		μV
SVR	Supply Voltage Rejection	$I_o = 40\text{ mA}$ $f = 120\text{ Hz}$ $T_j = 25\text{ }^\circ\text{C}$ $V_i = 18.5\text{ to }28.5\text{ V}$	34	39		dB
V_d	Dropout Voltage			1.7		V

ELECTRICAL CHARACTERISTICS FOR L78L18AB AND L78L18AC(refer to the test circuits, $V_i = 27\text{V}$, $I_o = 40\text{ mA}$, $C_i = 0.33\text{ }\mu\text{F}$, $C_o = 0.1\text{ }\mu\text{F}$, $T_j = 0\text{ to }125\text{ }^\circ\text{C}$ for L78L18AC, $T_j = -40\text{ to }125\text{ }^\circ\text{C}$ for L78L18AB, unless otherwise specified)

Symbol	Parameter	Test Conditions	Min.	Typ.	Max.	Unit
V_o	Output Voltage	$T_j = 25\text{ }^\circ\text{C}$	17.3	18	18.7	V
V_o	Output Voltage	$I_o = 1\text{ to }40\text{ mA}$ $V_i = 22\text{ to }33\text{ V}$ $I_o = 1\text{ to }70\text{ mA}$ $V_i = 27\text{ V}$	17.1 17.1		18.9 18.9	V V
ΔV_o	Line Regulation	$V_i = 22\text{ to }33\text{ V}$ $T_j = 25\text{ }^\circ\text{C}$ $V_i = 22\text{ to }33\text{ V}$ $T_j = 25\text{ }^\circ\text{C}$			320 270	mV mV
ΔV_o	Load Regulation	$I_o = 1\text{ to }100\text{ mA}$ $T_j = 25\text{ }^\circ\text{C}$ $I_o = 1\text{ to }40\text{ mA}$ $T_j = 25\text{ }^\circ\text{C}$			170 85	mV mV
I_d	Quiescent Current	$T_j = 25\text{ }^\circ\text{C}$ $T_j = 125\text{ }^\circ\text{C}$			6.5 6	mA mA
ΔI_d	Quiescent Current Change	$I_o = 1\text{ to }40\text{ mA}$			0.1	mA
ΔI_d	Quiescent Current Change	$V_i = 23\text{ to }33\text{ V}$			1.5	mA
eN	Output Noise Voltage	$B = 10\text{Hz to }100\text{kHz}$ $T_j = 25\text{ }^\circ\text{C}$		120		μV
SVR	Supply Voltage Rejection	$I_o = 40\text{ mA}$ $f = 120\text{ Hz}$ $T_j = 25\text{ }^\circ\text{C}$ $V_i = 23\text{ to }33\text{ V}$	33	38		dB
V_d	Dropout Voltage			1.7		V

ELECTRICAL CHARACTERISTICS FOR L78L24AB AND L78L24AC(refer to the test circuits, $V_i = 33\text{V}$, $I_o = 40\text{ mA}$, $C_i = 0.33\text{ }\mu\text{F}$, $C_o = 0.1\text{ }\mu\text{F}$, $T_j = 0\text{ to }125\text{ }^\circ\text{C}$ for L78L24AC, $T_j = -40\text{ to }125\text{ }^\circ\text{C}$ for L78L24AB, unless otherwise specified)

Symbol	Parameter	Test Conditions	Min.	Typ.	Max.	Unit
V_o	Output Voltage	$T_j = 25\text{ }^\circ\text{C}$	23	24	25	V
V_o	Output Voltage	$I_o = 1\text{ to }40\text{ mA}$ $V_i = 27\text{ to }38\text{ V}$ $I_o = 1\text{ to }70\text{ mA}$ $V_i = 33\text{ V}$	22.8 22.8		25.2 25.2	V V
ΔV_o	Line Regulation	$V_i = 27\text{ to }38\text{ V}$ $T_j = 25\text{ }^\circ\text{C}$ $V_i = 28\text{ to }38\text{ V}$ $T_j = 25\text{ }^\circ\text{C}$			350 300	mV mV
ΔV_o	Load Regulation	$I_o = 1\text{ to }100\text{ mA}$ $T_j = 25\text{ }^\circ\text{C}$ $I_o = 1\text{ to }40\text{ mA}$ $T_j = 25\text{ }^\circ\text{C}$			200 100	mV mV
I_d	Quiescent Current	$T_j = 25\text{ }^\circ\text{C}$ $T_j = 125\text{ }^\circ\text{C}$			6.5 6	mA mA
ΔI_d	Quiescent Current Change	$I_o = 1\text{ to }40\text{ mA}$			0.1	mA
ΔI_d	Quiescent Current Change	$V_i = 28\text{ to }38\text{ V}$			1.5	mA
eN	Output Noise Voltage	$B = 10\text{Hz to }100\text{kHz}$ $T_j = 25\text{ }^\circ\text{C}$		200		μV
SVR	Supply Voltage Rejection	$I_o = 40\text{ mA}$ $f = 120\text{ Hz}$ $T_j = 25\text{ }^\circ\text{C}$ $V_i = 29\text{ to }35\text{ V}$	31	37		dB
V_d	Dropout Voltage			1.7		V

Figure 1 : L78L05/12 Output Voltage vs Ambient Temperature

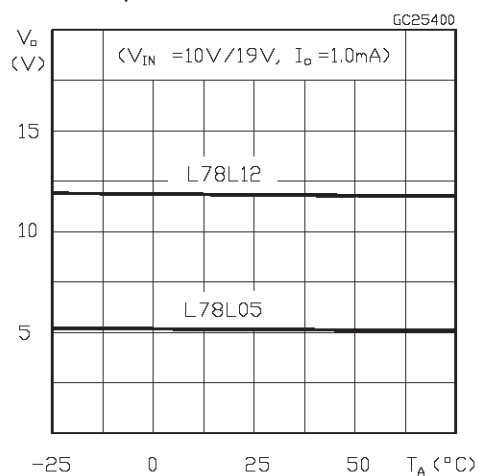

Figure 2 : L78L05/12/24 Load Characteristics.

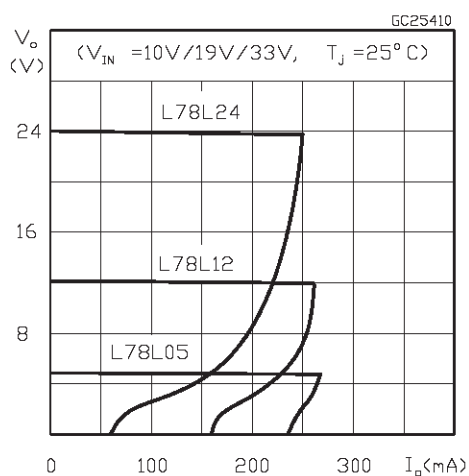

Figure 3 : L78L05/12/24 Thermal Shutdown.

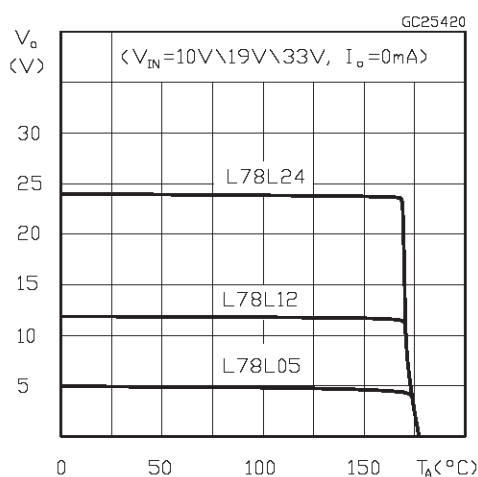

Figure 4 : L78L05/12 Quiescent Current vs Output Current

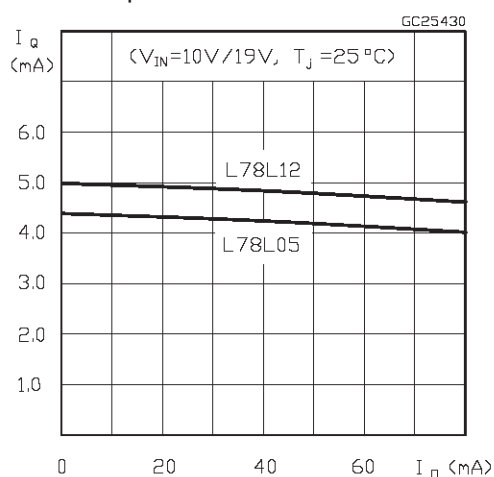

Figure 5 : L78L05 Quiescent Current vs Input Voltage

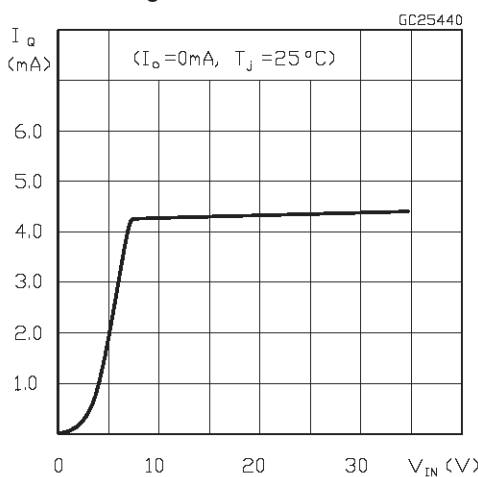
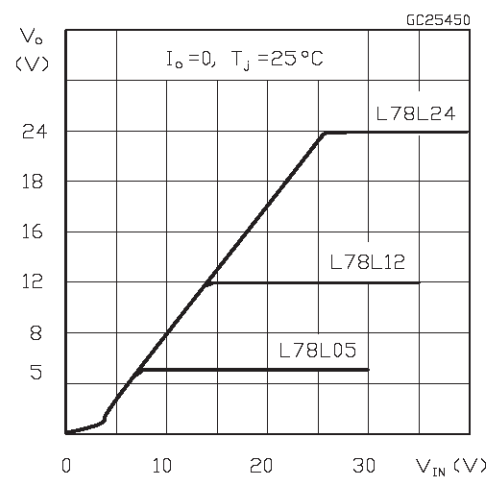

Figure 6 : L78L05/12/24 Output Characteristics.



L78L00

Figure 7 : L78L05/12/24Ripple Rejection.

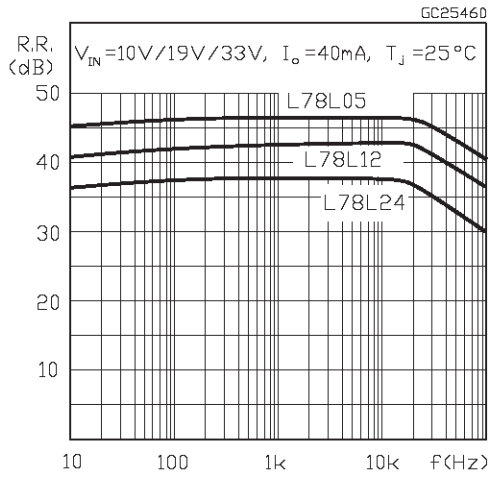

Figure 8 : L78L05 Dropout Characteristics.

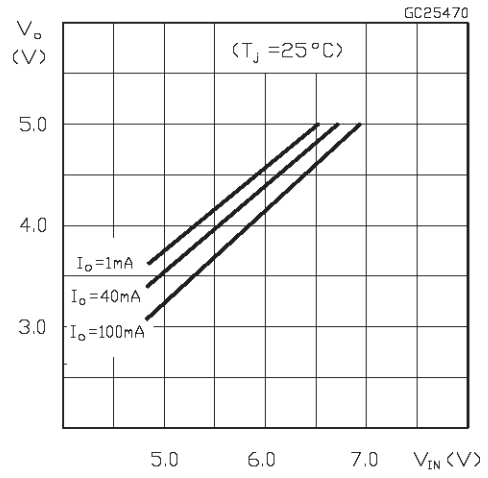
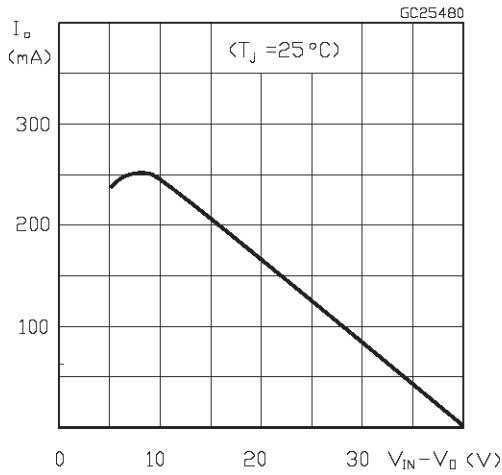

Figure 9 : L78L00 Series Short Circuit Output Current.



TYPICAL APPLICATIONS:

Figure 10: High Output Current Short Circuit Protected

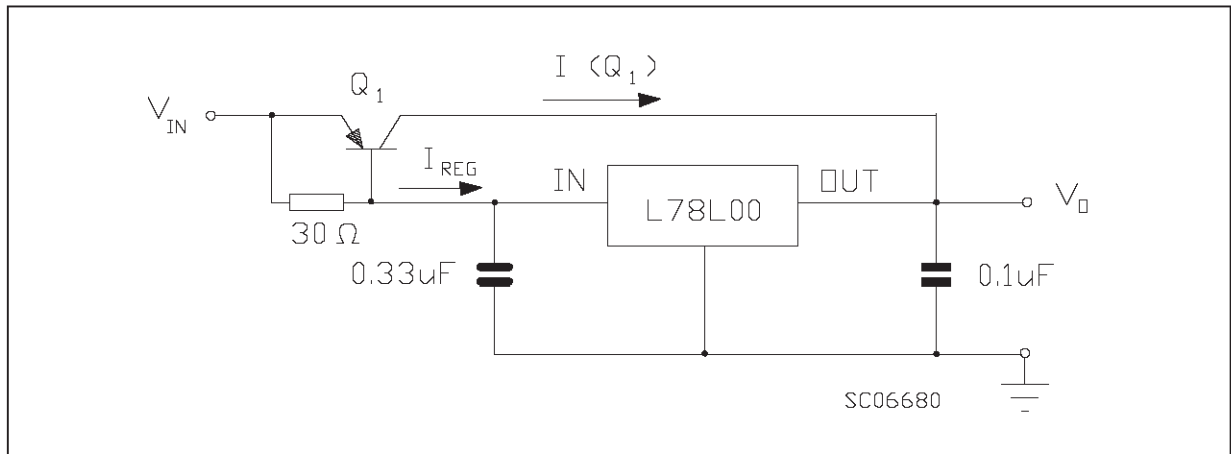

Figure 11 : Output Boost Circuit.

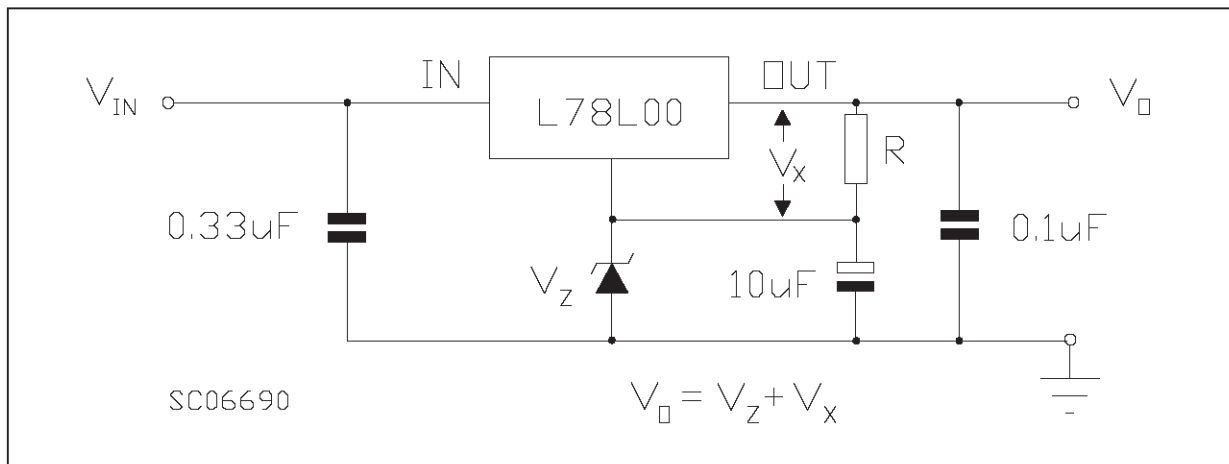

Figure 12 : Current Regulator.

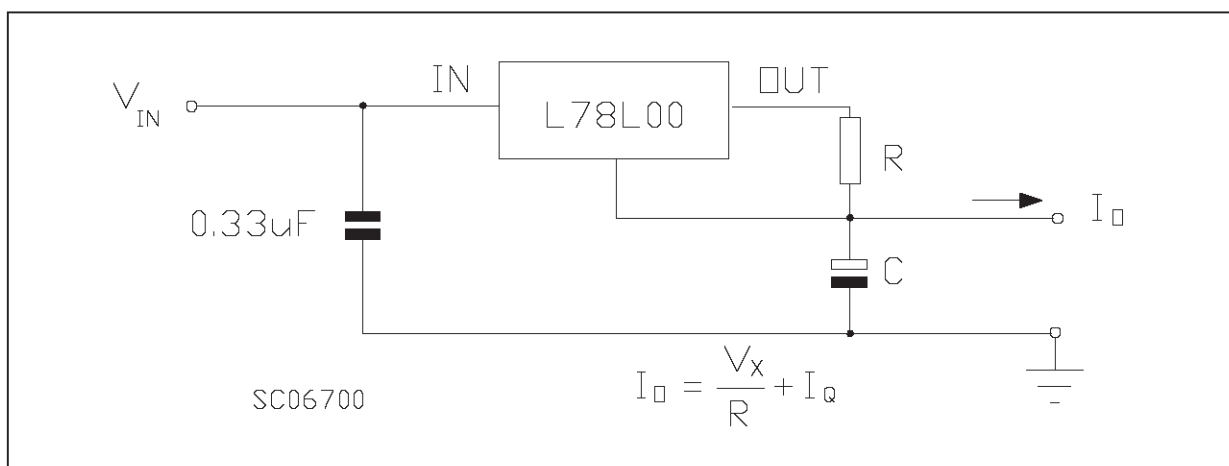
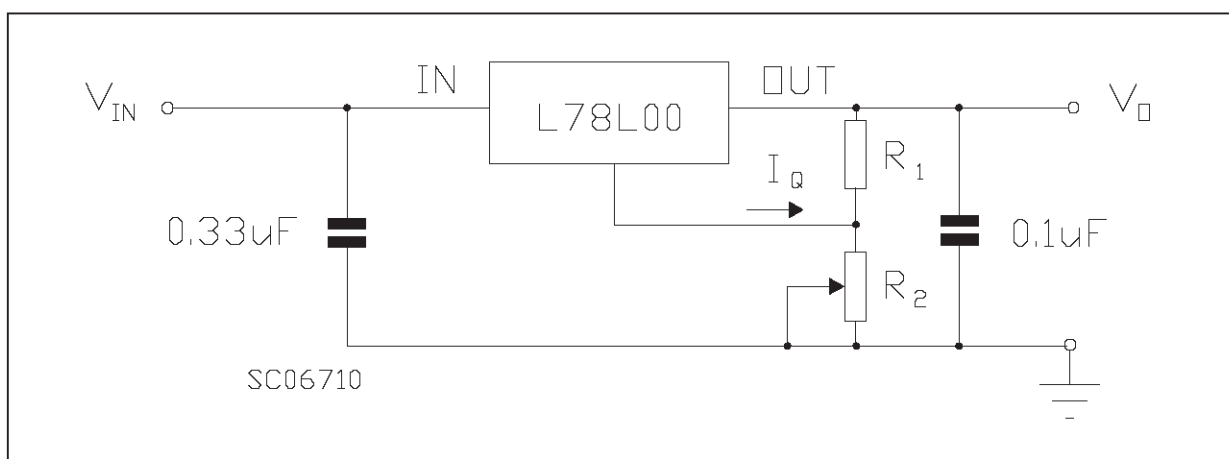
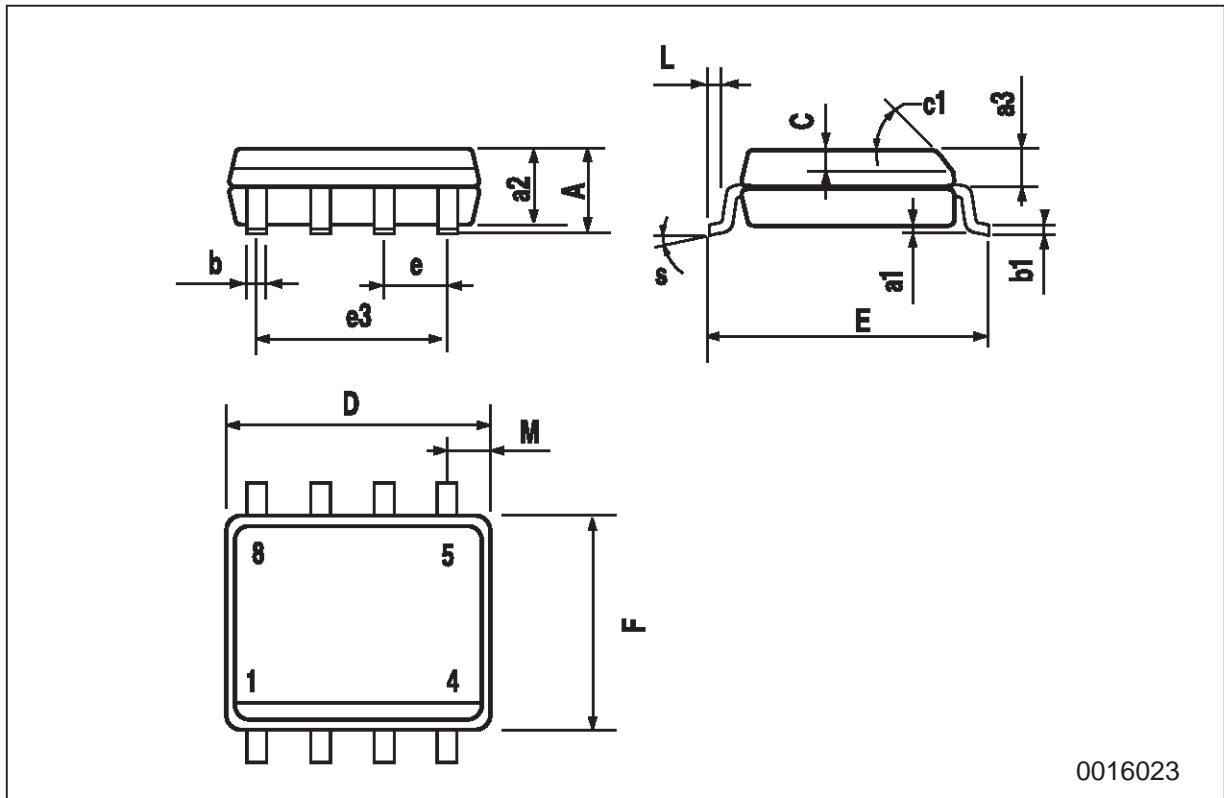

Figure 13: Adjustable Output Regulator



SO-8 MECHANICAL DATA

DIM.	mm			inch		
	MIN.	TYP.	MAX.	MIN.	TYP.	MAX.
A			1.75			0.068
a1	0.1		0.25	0.003		0.009
a2			1.65			0.064
a3	0.65		0.85	0.025		0.033
b	0.35		0.48	0.013		0.018
b1	0.19		0.25	0.007		0.010
C	0.25		0.5	0.010		0.019
c1	45 (typ.)					
D	4.8		5.0	0.188		0.196
E	5.8		6.2	0.228		0.244
e		1.27			0.050	
e3		3.81			0.150	
F	3.8		4.0	0.14		0.157
L	0.4		1.27	0.015		0.050
M			0.6			0.023
S	8 (max.)					



0016023

SOT-89 MECHANICAL DATA

DIM.	mm			mils		
	MIN.	TYP.	MAX.	MIN.	TYP.	MAX.
A	1.4		1.6	55.1		63.0
B	0.44		0.56	17.3		22.0
B1	0.36		0.48	14.2		18.9
C	0.35		0.44	13.8		17.3
C1	0.35		0.44	13.8		17.3
D	4.4		4.6	173.2		181.1
D1	1.62		1.83	63.8		72.0
E	2.29		2.6	90.2		102.4
e	1.42		1.57	55.9		61.8
e1	2.92		3.07	115.0		120.9
H	3.94		4.25	155.1		167.3
L	0.89		1.2	35.0		47.2

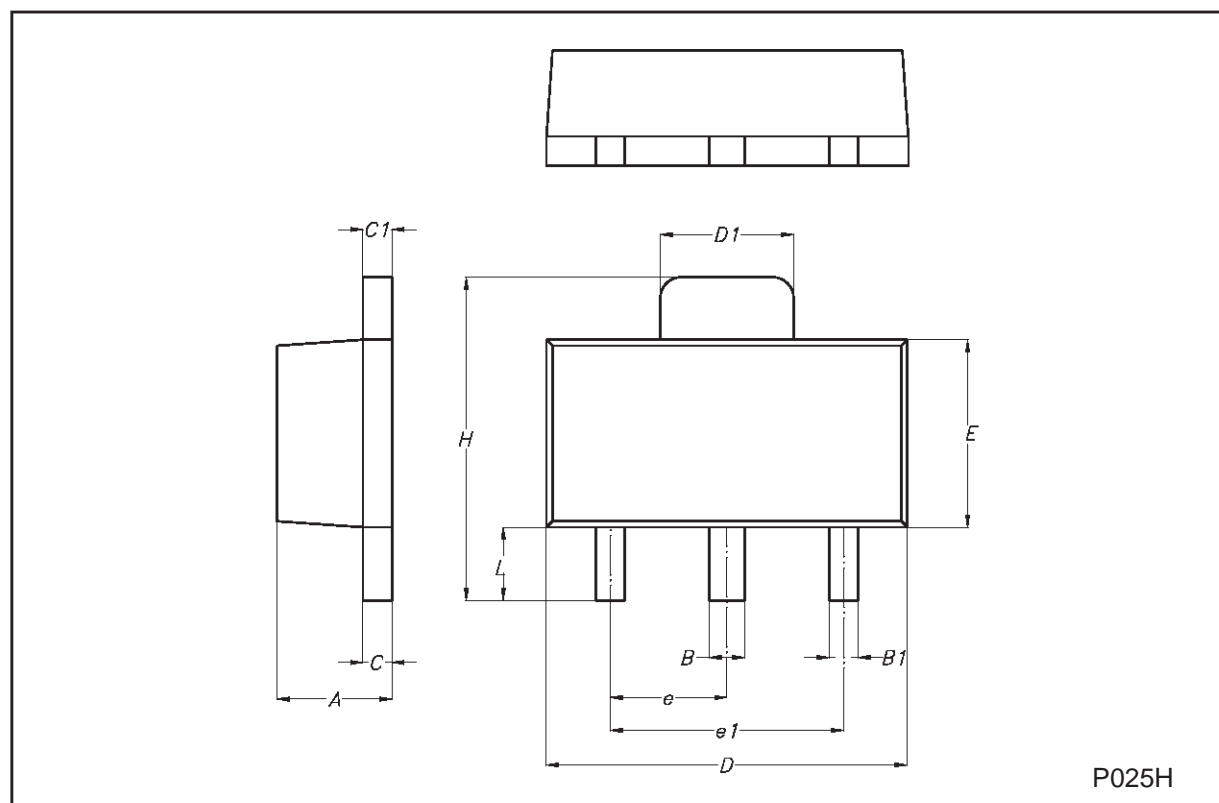

TO-92 MECHANICAL DATA

DIM.	mm			inch		
	MIN.	TYP.	MAX.	MIN.	TYP.	MAX.
A	4.58		5.33	0.180		0.210
B	4.45		5.2	0.175		0.204
C	3.2		4.2	0.126		0.165
D	12.7			0.500		
E		1.27			0.050	
F	0.4		0.51	0.016		0.020
G	0.35			0.14		

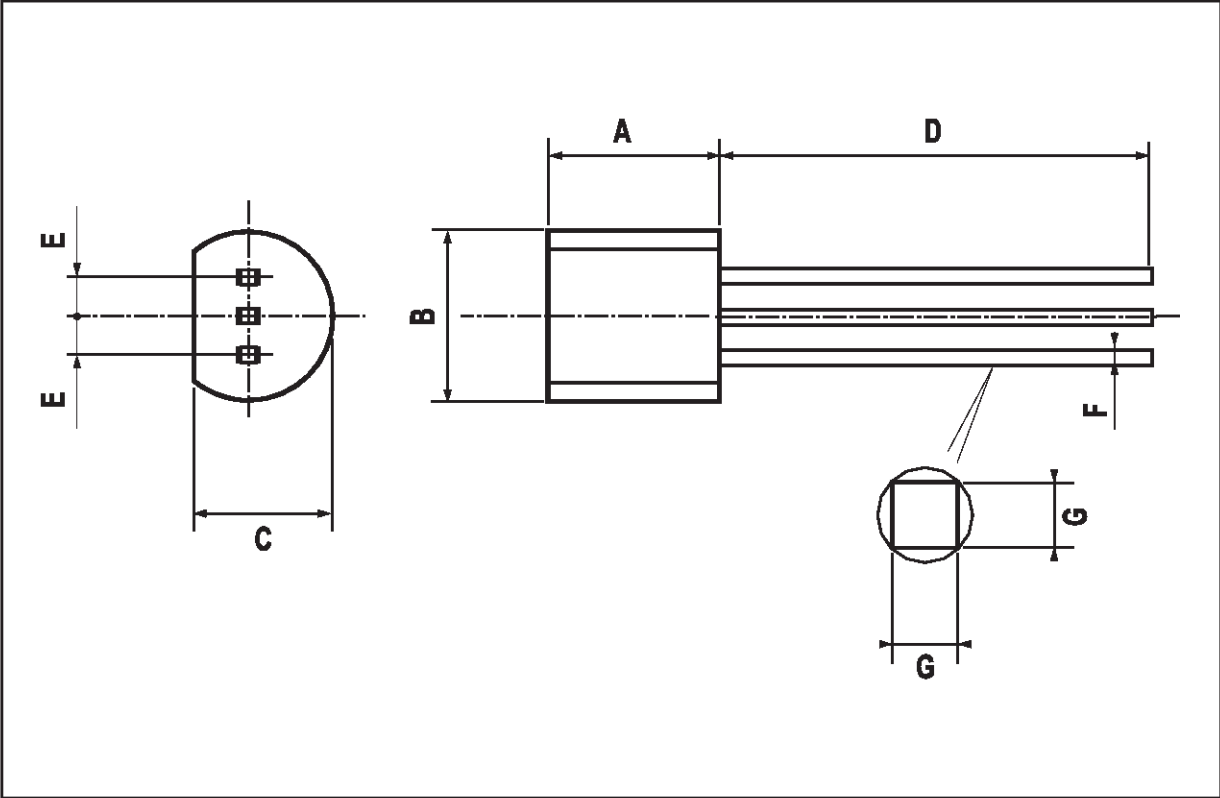

Information furnished is believed to be accurate and reliable. However, STMicroelectronics assumes no responsibility for the consequences of use of such information nor for any infringement of patents or other rights of third parties which may result from its use. No license is granted by implication or otherwise under any patent or patent rights of STMicroelectronics. Specification mentioned in this publication are subject to change without notice. This publication supersedes and replaces all information previously supplied. STMicroelectronics products are not authorized for use as critical components in life support devices or systems without express written approval of STMicroelectronics.

The ST logo is a trademark of STMicroelectronics

© 1999 STMicroelectronics – Printed in Italy – All Rights Reserved

STMicroelectronics GROUP OF COMPANIES

Australia - Brazil - Canada - China - France - Germany - Italy - Japan - Korea - Malaysia - Malta - Mexico - Morocco - The Netherlands - Singapore - Spain - Sweden - Switzerland - Taiwan - Thailand - United Kingdom - U.S.A.

<http://www.st.com>

This datasheet has been downloaded from:

www.DatasheetCatalog.com

Datasheets for electronic components.



LittleDiode supplies new, hard to find or obsolete electronic components and semiconductors all over the world.

With over two million different components listed you are sure to find the part you need.

Feel free to visit us today at our online store:

LittleDiode.com

Looking forward to providing you with the best possible service.