

DBL 1027

DUAL PREAMPLIFIER WITH ALC

The DBL 1027 is a monolithic integrated circuit consisting of two independent preamplifier with two built-in ALC, and it has quick stabilization during power supply input.

FEATURES

- High voltage gain
- Excellent channel separation
- Low noise
- Direct motor drive obtained through SEPP output stage.
- Good ALC channel balance
- Operating supply voltage range : $V_{CC} = 5V \sim 13V$
- Load resistance : $R_L > 680 \Omega$

APPLICATIONS

- Stereo radio cassettes

MAXIMUM RATINGS ($T_a = 25^\circ C$)

Characteristic	Symbol	Rating	Unit
Supply Voltage	V_{CC}	14	V
Power Dissipation	P_D	600	mW
Operating Temperature	T_{opr}	$-20 \sim +75$	$^\circ C$
Storage Temperature	T_{stg}	$-40 \sim +125$	$^\circ C$

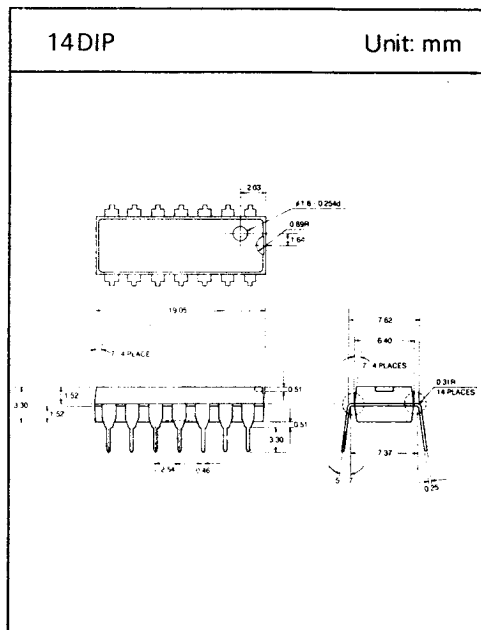

DBL 1027

ELECTRICAL CHARACTERISTICS

(Unless otherwise specified, $T_a = 25^\circ\text{C}$, $V_{CC} = 5\text{V}$, $f = 1\text{KHz}$, $R_L = 10\text{K}\Omega$ (PLAY), $R_L = 680\Omega$ (REC))

Characteristic	Symbol	Test Condition	Min.	Typ.	Max.	Unit
Quiescent Supply Current	I_{CCQ}	—	—	4.5	10	·mA
Open-loop Voltage Gain	G_{VO}	—	—	85	—	dB
Closed-loop Voltage Gain	G_V	PLAY	—	40	—	dB
		REC	—	58	—	dB
Maximum Output Voltage	V_{OM}	THD = 1%, PLAY	0.9	1.2	—	V
Total Harmonic Distortion	THD	$V_O = 0.5\text{V}$, PLAY	—	0.1	1	%
Input Resistance	R_{IN}	—	21	30	—	K Ω
Equivalent Input Noise Voltage	V_{NI}	B.P.F. = 20Hz~20KHz $R_g = 2.2\text{K}\Omega$, PLAY	—	1	2	μV
Channel Separation	CH_{SEP}	$R_g = 2.2\text{K}\Omega$ $V_O = 0\text{dBm}$, PLAY	40	50	—	dB
ALC Channel Balance	ACB	$V_{IN} = -20\text{dBm}$, REC.	—	0	2	dB
ALC Width	AW	$V_{IN} = -60\text{dBm}$, REC.	35	45	—	dB
ALC Distortion	AD	$V_{IN} = -20\text{dBm}$, REC.	—	0.5	2	%

BLOCK DIAGRAM

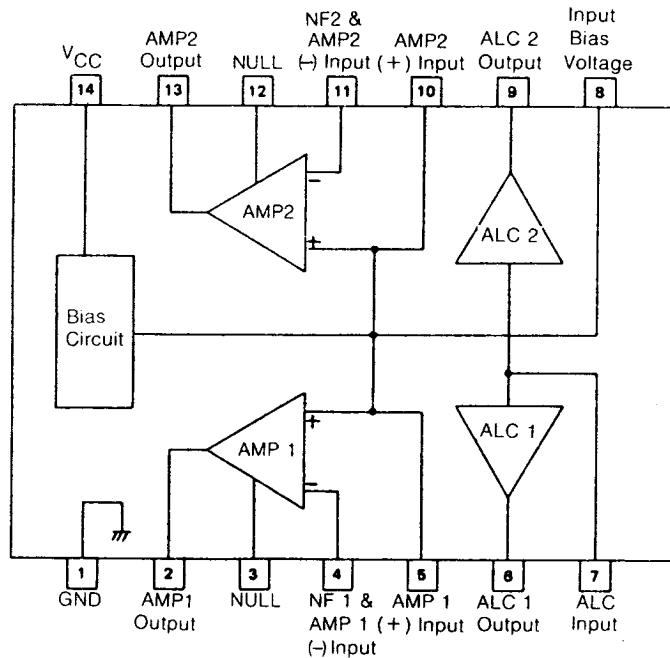

DBL 1027

TEST CIRCUIT

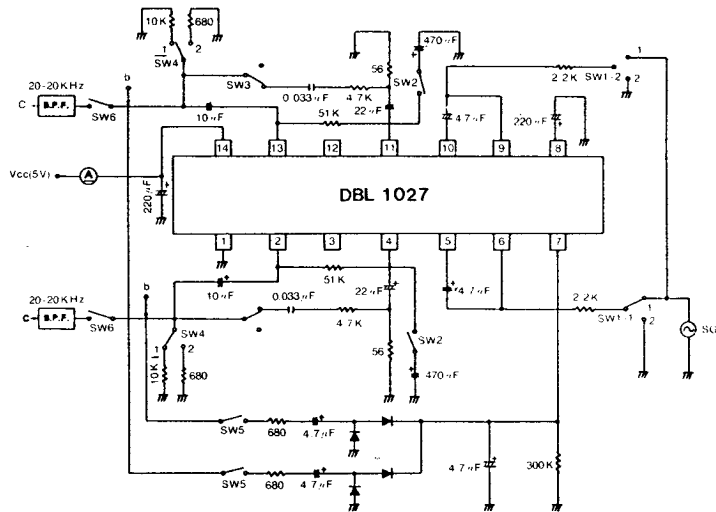

TEST METHOD

Symbol	Switch Position						Measurement Location	Test Method
	SW1	SW2	SW3	SW4	SW5	SW6		
I_{CCQ}	2	OFF	OFF	1	OFF	OFF	—	Read ammeter
G_{VO}	1	ON	OFF	1	OFF	OFF	a,b	$G_{VO} = 20 \log \frac{V_O}{V_{IN}}$ (dB)
G_V	1	OFF	ON	1	OFF	OFF	a,b	$G_V = 20 \log (V_O/V_{IN})$ (dB)
V_{OM}	1	OFF	ON	1	OFF	OFF	b	Measure output voltage (V_O) at THD = 1%
THD	1	OFF	ON	1	OFF	OFF	b	Measure distortion factor at $V_O = 0.5V$
CH_{SEP}	SW1-1 1→2 SW1-2 2→1	OFF	ON	1	OFF	OFF	b	Measure crosstalk of amp 1,2 at output voltage $V_O = 0dBm$
V_{NI}	2	OFF	ON	1	OFF	ON	c	Convert output noise voltage at 1KHz gain when $R_g = 2.2K \Omega$
AW	1	OFF	OFF	2	ON	OFF	b	Input voltage range from when input voltage $V_{IN} = -60dBm$ until output voltage V_O goes up 3dB
ACB	1	OFF	OFF	2	ON	OFF	b	Output voltage V_O level difference of amp 1,2 when input voltage $V_{IN} = -20dBm$ is applied
AD	1	OFF	OFF	2	ON	OFF	b	Measure distortion factor when input voltage $V_{IN} = -20dBm$ is applied.

□ INFORMATION OF OPERATING

1. ALC Circuit

The ALC circuit is consist of Q1, Q2 and some external components. The output level of amplifier is rectified by external circuits and this rectified DC level is applied to the ALC input terminal(Pin 7).

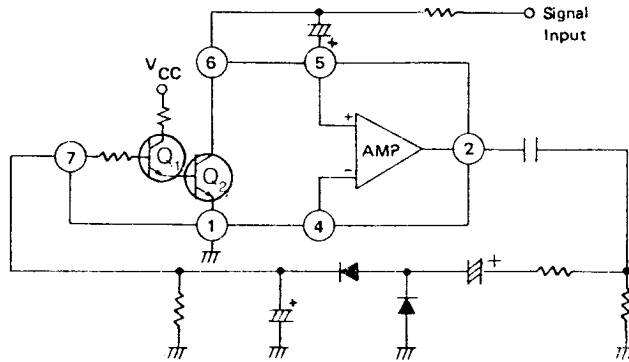

2. Closed-loop Gain (f=1KHz)

- Closed loop voltage gain

$$G_V = 20\log(Z1/Z3) \text{ (dB)}$$

- Playback amplifier gain

$$G_V = 20\log(R1/R3) \text{ (dB) in low frequency}$$

$$G_V = 20\log(Z1/Z3) \text{ (dB) in high frequency}$$

- Recording amplifier gain

$$G_V = 20\log(R1/R3) \text{ (dB)}$$

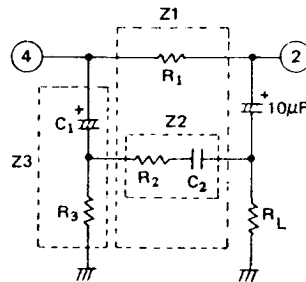

3. Oscillation

When the closed-loop gain of amplifier is lowered, oscillation with occur. So the circuit should be compensated by connecting of 10pF between pin 3 and pin 2, and 0.03µF in series with 10 Ω to the load end.

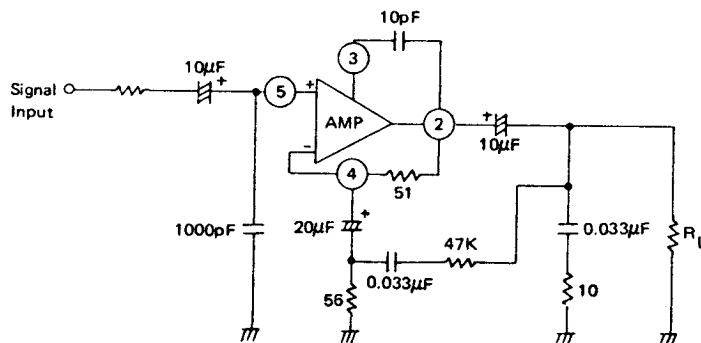

DBL 1027

TYPICAL PERFORMANCE CHARACTERISTICS

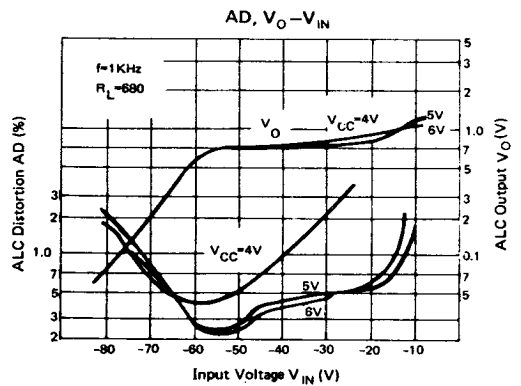
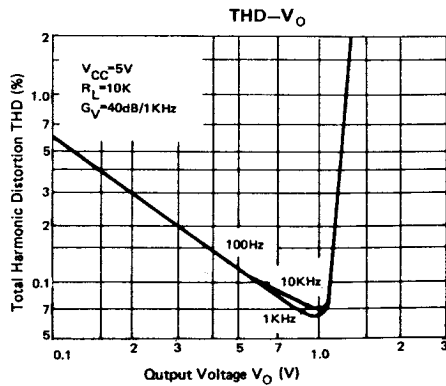
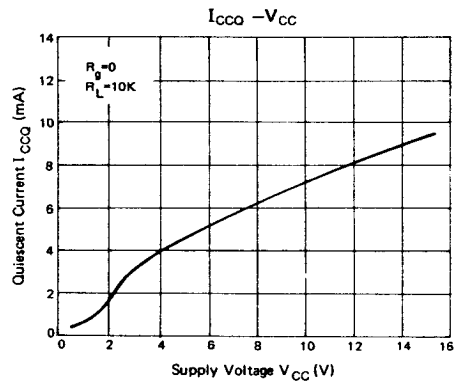
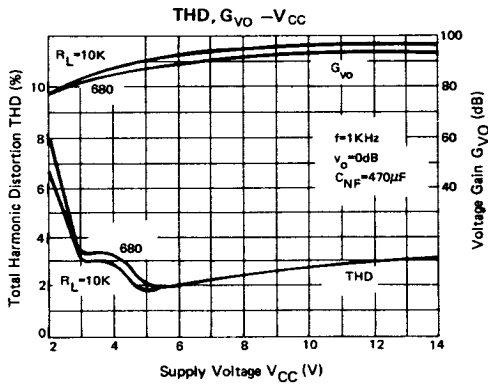
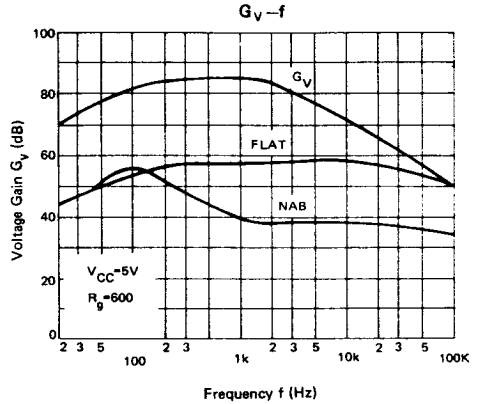
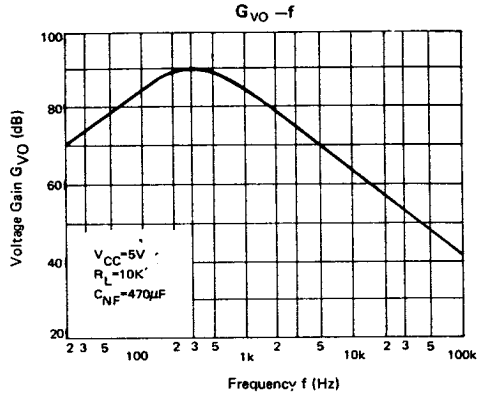

This datasheet has been downloaded from:

www.DatasheetCatalog.com

Datasheets for electronic components.



LittleDiode supplies new, hard to find or obsolete electronic components and semiconductors all over the world.

With over two million different components listed you are sure to find the part you need.

Feel free to visit us today at our online store:

LittleDiode.com

Looking forward to providing you with the best possible service.