

## DEFLECTION COMBINATION FOR A C-TV

DBL 2009 is a monolithic integrated circuit designed for deflection combination in C-TV or C-Monitor receivers.

### FUNCTION

- Sync separation
- Vertical oscillation
- Vertical drive
- Horizontal AFC
- Horizontal oscillation
- X-ray protection

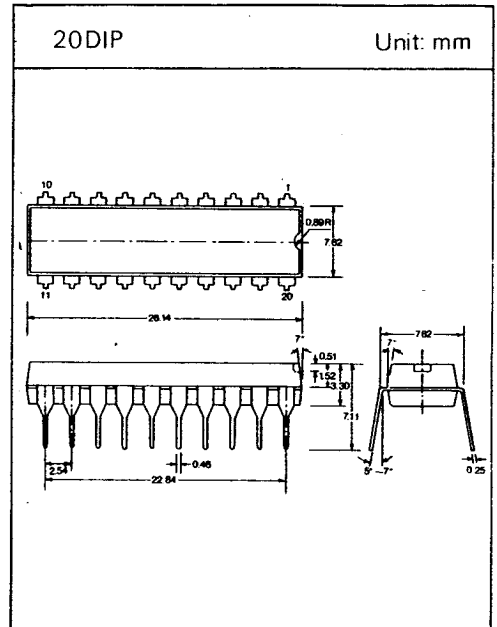

### MAXIMUM RATINGS(Ta=25°C)

Characteristic	Symbol	Rating	Unit
Vertical Supply Voltage	$V_{CC}$	16	V
Horizontal Supply Current	$I_{CC}$	25	mA
Power Dissipation(Ta = 75°C)	$P_D$	500	mW
Operating Temperature	$T_{opr}$	-20 ~ +75	°C
Storage Temperature	$T_{stg}$	-55 ~ +150	°C
Output Current(Pin 2, Pin 10 and Pin 16)	$I_o$	15	mA

PIN CONNECTIONS AND PIN VOLTAGES.

( $V_{CC} = 12V$ )

Pin No.	Functions	Voltage Values			Unit
		min.	typ.	max.	
1	Connected to Capacitor for Prevention of Parastic Oscillation		3.3		V
2	Vertical Output Pin		1.1		V
3	Feedback Input Pin for Vertical DC/AC Output Voltage		3.3		V
4	Connected to Resistor for Determination of the Vertical Osc Discharging Time Constant	3.3	4	4.2	V
5	Connected to Capacitor for Vertical Osc		7.1		V
6	Power Supply Pin for Vertical Oscillator		12		V
7	Vertical Sync Input Pin		5		V
8	Determination of Vertical Osc Frequency		5.1		V
9	Input Pin for X-Ray Protector		0		V
10	Output Pin for Horizontal Section		1		V
11	Power Supply Pin for Horizontal Oscillator	11.8	12.8	13.8	V
12	Connected to Horizontal Osc CR		6.5		V
13	FBP Input Pin For Phase Detector		3.6		V
14	Output Pin for Phase Detector		6.6		V
15	Video Signal Input Pin for Sync Separator		12.5		V
16	Output Pin for Sync Separator		1		V
17	Feedback Pin for Sync Separator		2.5		V
18	GND Pin		0		V

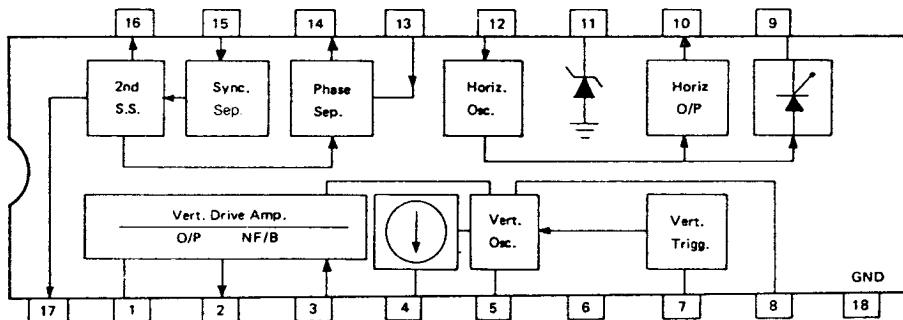

## □ ELECTRICAL CHARACTERISTICS

1. Horizontal Section(Ta = 25°C)

Characteristic	Symbol	Test Circuit	Test Conditions	Min.	Typ.	Max.	Unit
Regulated Voltage	$V_{11}$	2	19.9V Applied to 11-Pin via 470Ω	11.8	12.8	13.8	V
Supply Current	$I_{CC}$	2	19.9V Applied to 11-Pin via 470Ω	12.9	15	17.3	mA
Osc Frequency	$f_{OH}$	2	$R_H = 12.6K\Omega$ ; $C_H = 5.6nF$	14734	15734	16734	Hz
Horizontal Pull-in Range	$\Delta f_{pH}$	1		±450	±650		Hz
AFC Loop Gain	$f_C$	1		577.5	750	1070	Hz/μS
Temperature Coefficient of $f_{OH}$	$\Delta f_{OH-Ta}$	2	$C_H = 5.6nF$ ; $R_H = 12.6K\Omega$ ; $C_H$ and $R_H$ Is Set Outside the Constant Temperature Bath	-6	-3	0	Hz/°C
Output Pulse Width	$t_{HW}$	1	Measure at 10-Pin	22.5	25	27.5	μS
$f_{OH}$ Stability against $V_{CC}$ Variation	$\Delta f_{OH-VCC}$	2	The Osc Frequency Difference with $V_{CC}$ Varied from 11.5V to 12.8V	-100	0	100	Hz
Output Saturation Voltage	$V_{CE(sat)}$	2	12KΩ Inserted between 10-Pin and GND			0.3	V
Output High Voltage	$V_{10H}$	7	Adjust Current, at 10-Pin for -6.5mA	2.8	4.1	6.8	V
Osc Starting Supply Voltage	$V_{OHS}$	2	$f_{OH} = 10KHz \sim 20KHz$		2	6	V

## □ ELECTRICAL CHARACTERISTICS

2. Vertical Section.(Ta = 25°C)

Characteristic	Symbol	Test Circuit	Test Conditions	Min.	Typ.	Max.	Unit
Osc Frequency	$f_{OV}$	3	$R_V = 6K\Omega$ ; $C_V = 2.2\mu F$	55	60	65	Hz
Vertical Pull-in Range	$\Delta f_{PV}$	1			-10	-7.5	Hz
Temperature Coefficient of $f_{OV}$	$\Delta f_{OV-Td}$	3	$R_V = 6K\Omega$ ; $C_V = 2.2\mu F$	-0.03	0	+0.03	Hz/°C
$f_{OV}$ Stability against $V_{CC}$ Variation	$\Delta f_{OV-VCC}$	3	Measure the Osc Frequency Difference with $V_{CC}$ Varied from 14.4V to 9.6V	-2	0	2	Hz
Output High Voltage(1)	$V_{2h(1)}$	6	5V at Pin 1; 6V at Pin 3; 15V at Pin 6 Measure Voltage at Pin 2 with 15mA Drawn from Pin 2	9.5	11.5	13.5	V
Output High Voltage(2)	$V_{2h(2)}$	6	5V at Pin-1; 6V at Pin 3 15V at Pin 6 Measure Voltage at Pin 2 with No Load Applied to Pin 2	12.8	13.7	14.5	V
Vertical Osc Starting Voltage	$V_{OVS}$	3	$R_V = 6K\Omega$ ; $C_V = 2.2\mu F$ ; $f_{OV} = 40Hz \sim 70Hz$		5	9	V

ELECTRICAL CHARACTERISTICS(continued)

3. Sync Separation Section. (Ta = 25°C)

Characteristic	Symbol	Test Circuit	Test Conditions	Min	Typ.	Max.	Unit
Input Voltage	V <sub>15</sub>	4	Negative Pulse Applied to Pin 15	0.2			V <sub>p-p</sub>
Output Voltage	V <sub>16</sub>	4	Measure at Pin 16	8	10		V <sub>p-p</sub>
Output Pulse Width(1)	t <sub>16(1)</sub>	4	APL = 50%; 2.5V <sub>p-p</sub> applied at the Input Point	4.5	5	5.5	μs
Output Pulse Width(2)	t <sub>16(2)</sub>	4	APL = 50%; 1.0V <sub>p-p</sub> applied at the Input Point	4.5	5	5.5	μs

4. X-Ray Protection Section. (Ta=25°C)

Characteristic	Symbol	Test Circuit	Test Conditions	Min.	Typ.	Max.	Unit
Trigger Gate Voltage	V <sub>GT</sub>	5	R = 4.7 Ω and C = 33 μF/16V as the External Parts for Pin 9	0.68	0.75	0.82	V
Temperature Coefficient of V <sub>GT</sub>	ΔV <sub>GT-Ta</sub>	5	R = 4.7K Ω and C = 33 μF/16V as the EXternal Parts for Pin9		-2.5		mV/°C
V <sub>CC</sub> Dependence of V <sub>GT</sub>	ΔV <sub>GT</sub> V <sub>CC</sub>	5	R = 4.7K Ω and C = 33 μF/16V as the External Parts for Pin 9		-30		mV/°C



□ TEST CIRCUITS(Continued)

2.  $f_{OH}$  and  $\Delta f_{OH}$

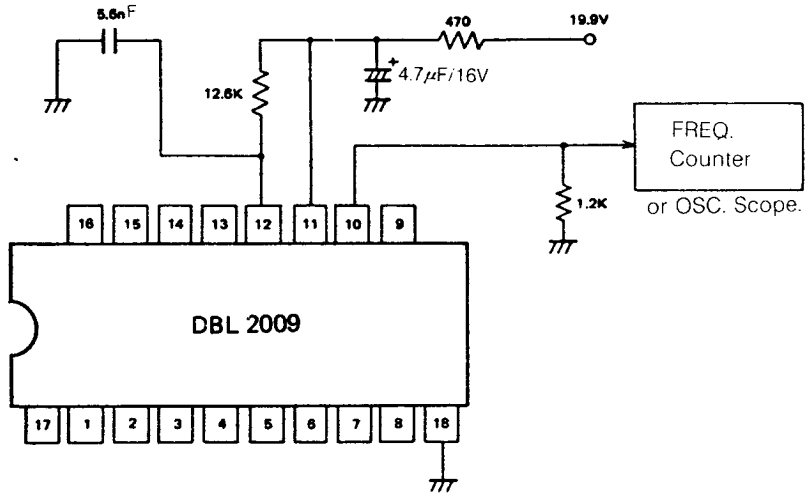

3.  $f_{OV}$  and  $\Delta f_{OV}$

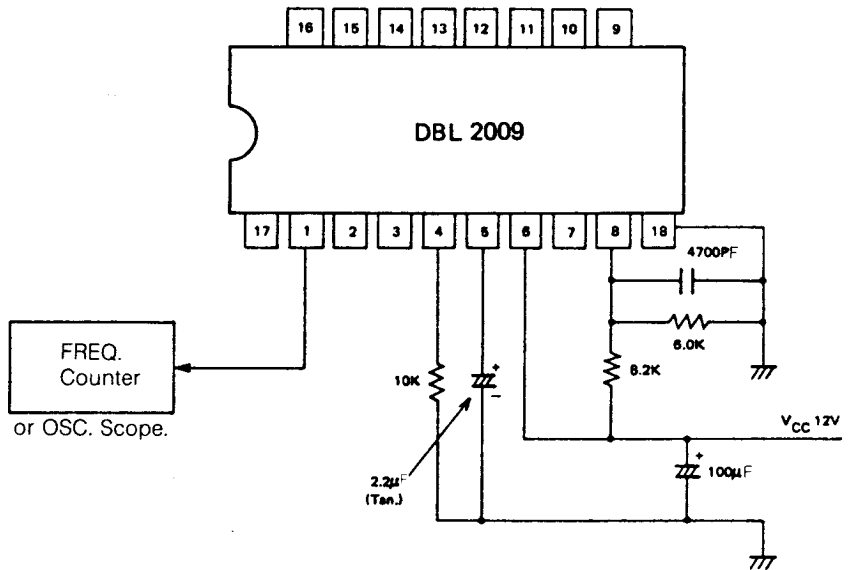

# DBL 2009

## □ TEST CIRCUITS(Continued)

### 4. Sync. Separation

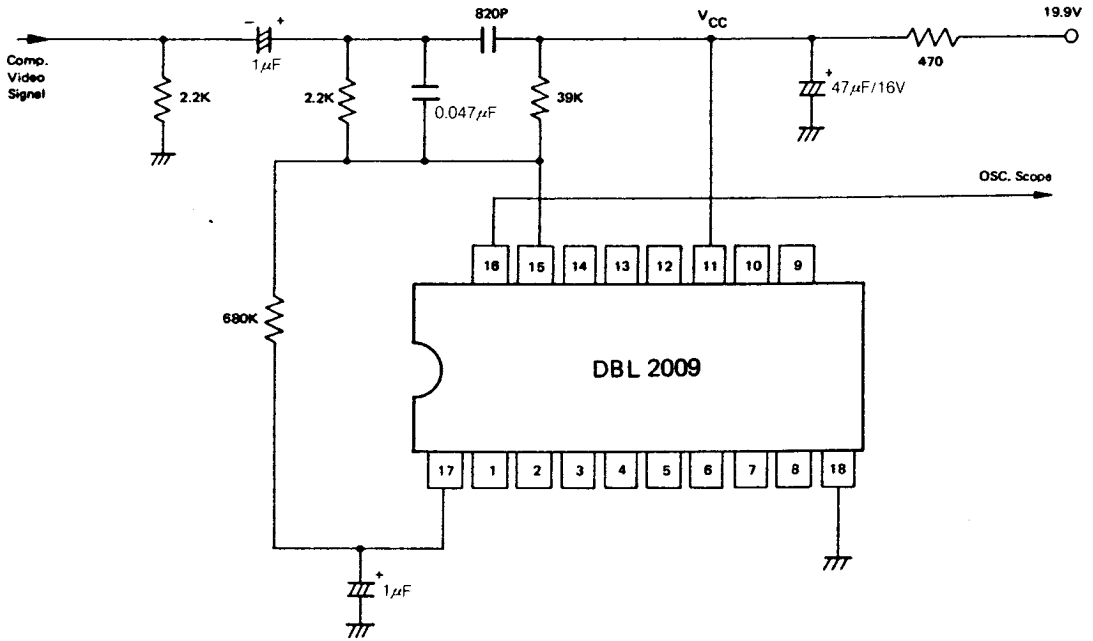

### 5. X-Ray Protection Block

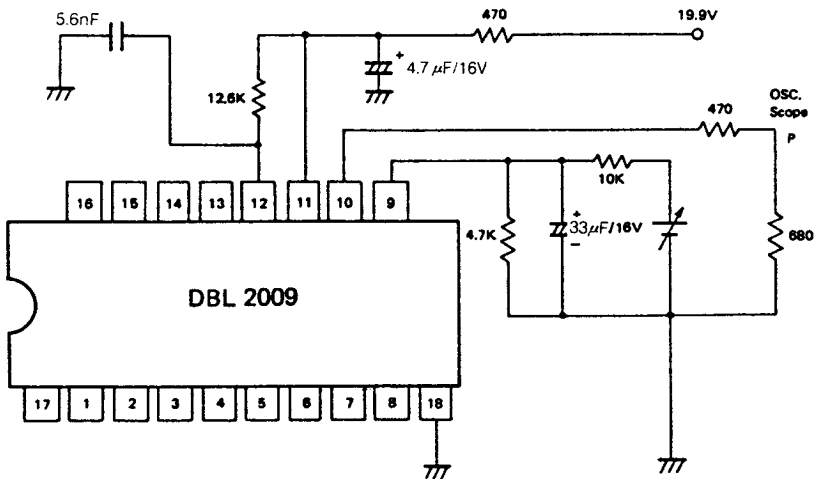

## □ TEST CIRCUITS(Continued)

### 6. Vertical Output

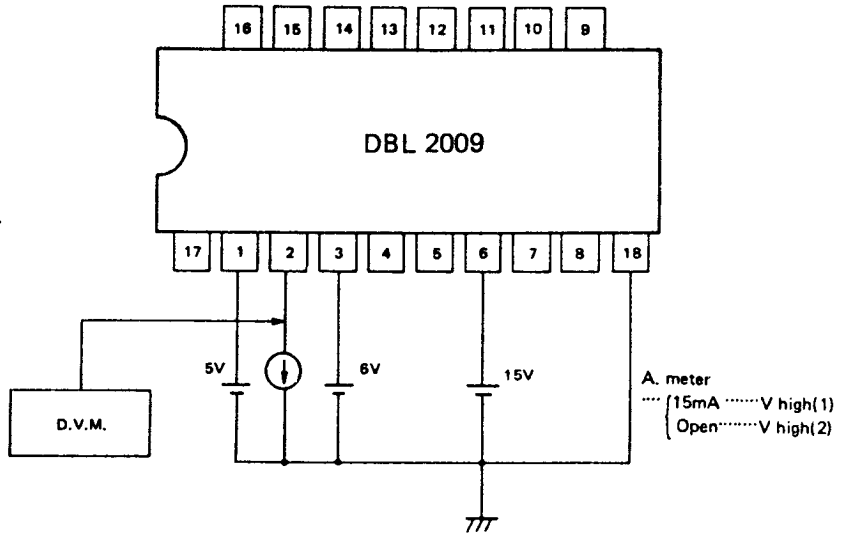

### 7. Horizontal Output

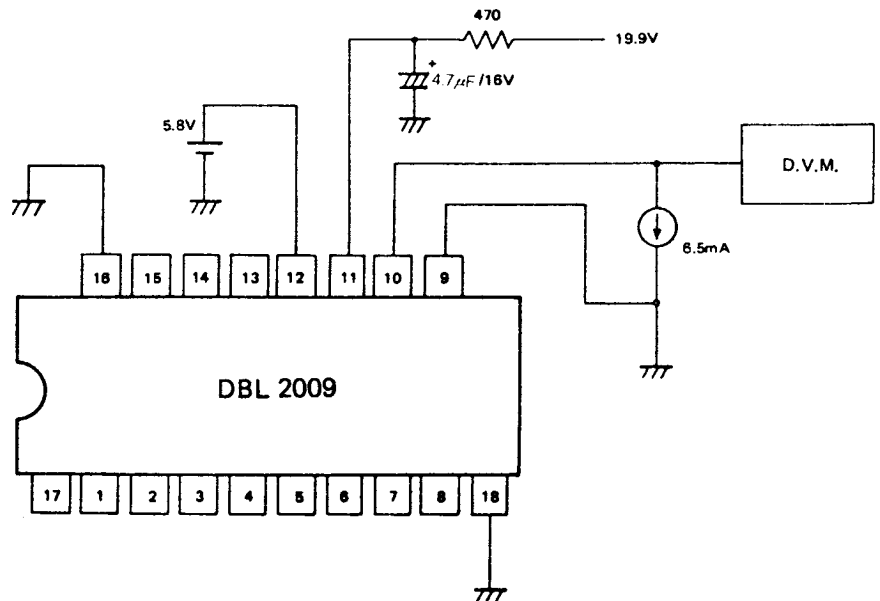



LittleDiode supplies new, hard to find or obsolete electronic components and semiconductors all over the world.

With over two million different components listed you are sure to find the part you need.

Feel free to visit us today at our online store:

[LittleDiode.com](http://LittleDiode.com)

Looking forward to providing you with the best possible service.