

DBL 5018

LOW POWER NARROW BAND FM IF

The DBL5018 is designed for use in FM dual conversion communication.

It contains a complete narrow band FM demodulation system operable to less than 2.0V supply voltage. This low power narrow band FM IF system provides the second converter, second IF, demodulator, Filter Amp and squelch circuitry for communications and scanning receivers.

FEATURES

- Operating voltage range : 2.0V~8.0V
- Low Current Consumption $I_{CC}=4.0\text{mA}$ Typ.
($V_{CC}=4.0\text{V}$)
- Excellent input sensitivity
(-3dB Limiting= $2.0\mu\text{Vrms}$ Typ.)
- Low number of external parts required
- Operating frequency up to 60MHZ

MAXIMUM RATINGS($T_a=25^\circ\text{C}$)

| Characteristics | Symbol | Rating | Unit |
|----------------------------------------------|--------------|-----------|------------------|
| Maximum Supply voltage | $V_{CC,MAX}$ | 10 | V |
| Supply Voltage Range | V_{CC} | 2.0~8.0 | V |
| Detector input Voltage | $V_{IN,DET}$ | 1.0 | V_{p-p} |
| RF Input Voltage($V_{CC}\geq 4.0\text{v}$) | $V_{IN,RF}$ | 1.0 | V_{rms} |
| Mute Function | V_{MUTE} | -0.5~+5.0 | V_{peak} |
| Operating Temperature | T_{op} | -2.0~+70 | $^\circ\text{C}$ |
| Storage Temperature | T_{stg} | -65~+150 | $^\circ\text{C}$ |

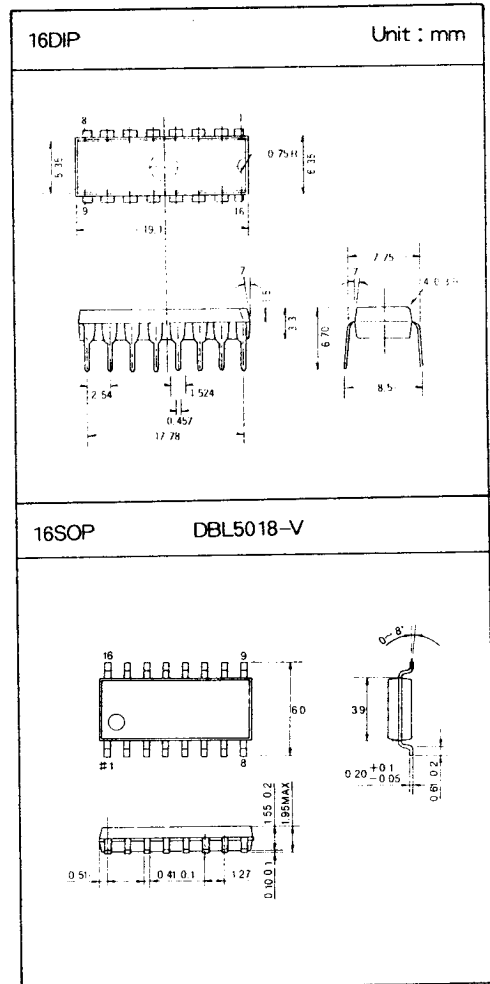

DBL 5018

PIN CONFIGURATION

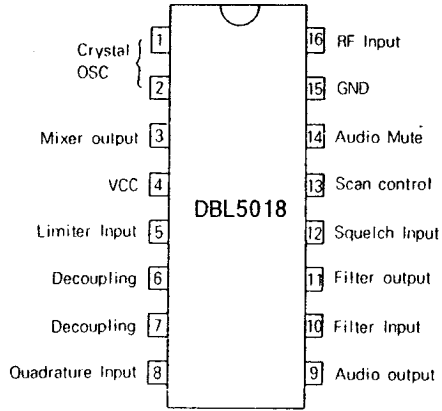

BLOCK DIAGRAM AND TEST CIRCUIT

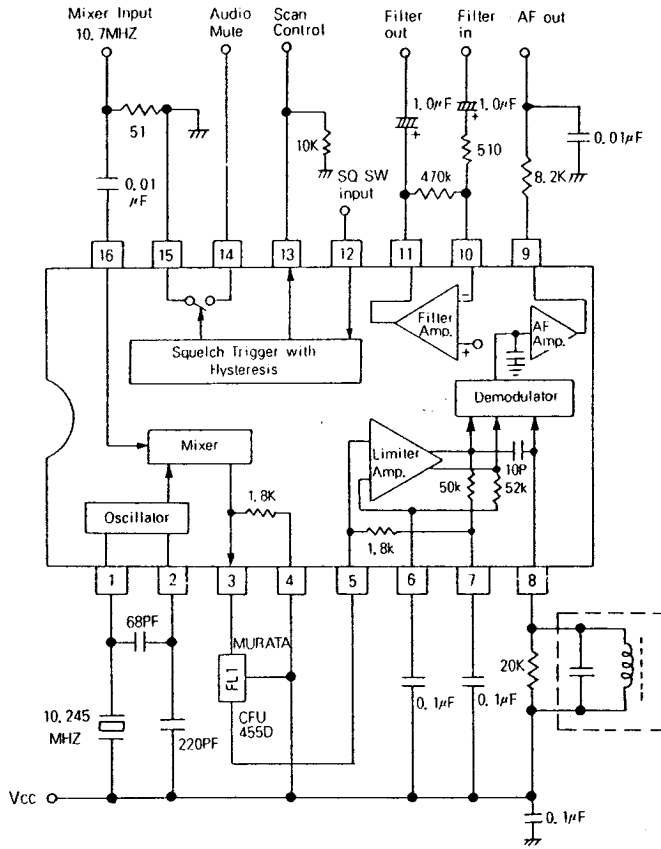

DBL 5018

APPLICATION CIRCUIT

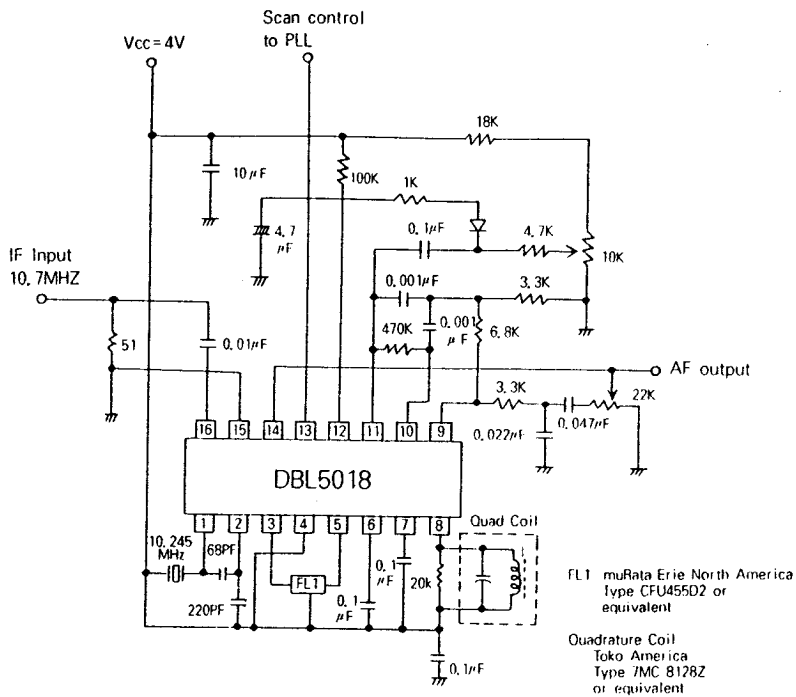

TYPICAL PERFORMANCE CHARACTERISTICS

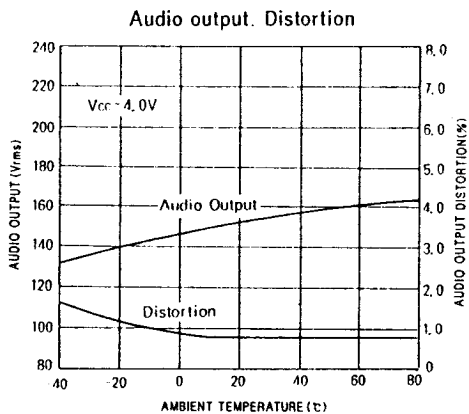
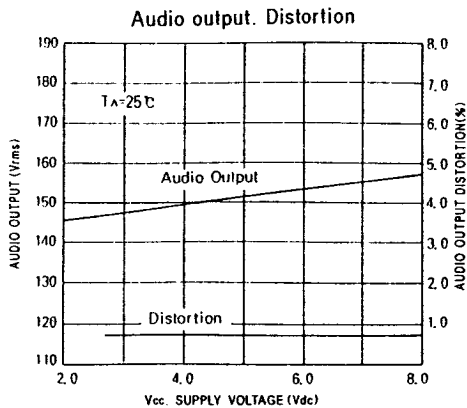

DBL 5018

□ TYPICAL PERFORMANCE CHARACTERISTICS

Input Limiting Voltage

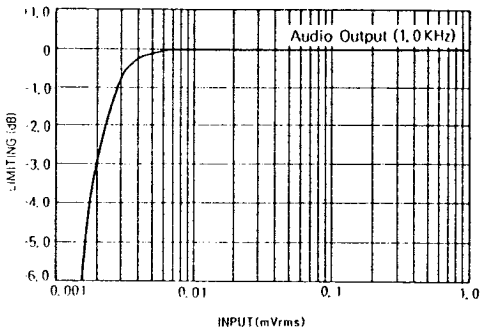

Overall Gain, Noise, and A.M. Rejection

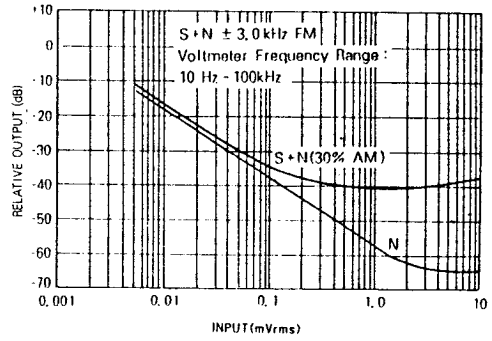

Filter AMP Response

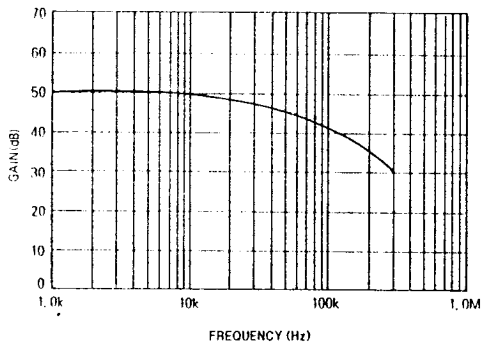

Filter AMP Gain

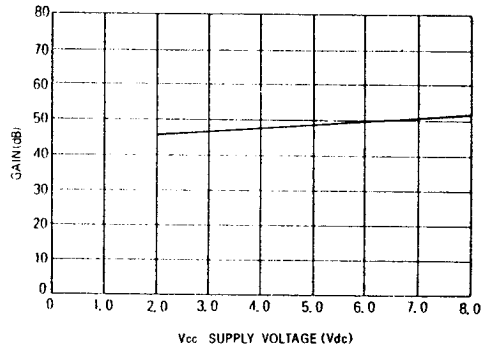

Supply Current

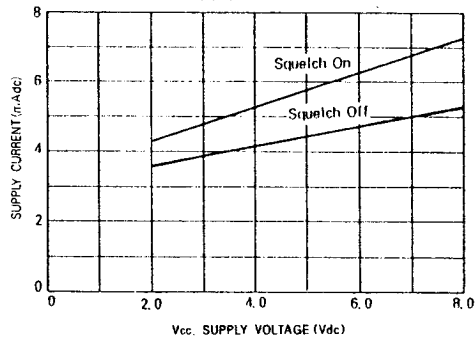



LittleDiode supplies new, hard to find or obsolete electronic components and semiconductors all over the world.

With over two million different components listed you are sure to find the part you need.

Feel free to visit us today at our online store:

LittleDiode.com

Looking forward to providing you with the best possible service.