

SILICON N-CHANNEL DUAL GATE MOS-FET

Depletion type field-effect transistor in a plastic X-package with source and substrate interconnected, intended for VHF applications, such as VHF television tuners, FM tuners and professional communication equipment.

This MOS-FET tetrode is protected against excessive input voltage surges by integrated back-to-back diodes between gates and source.

QUICK REFERENCE DATA

Drain-source voltage	V_{DS}	max.	20 V
Drain current	I_D	max.	20 mA
Total power dissipation up to $T_{amb} = 75^\circ\text{C}$	P_{tot}	max.	225 mW
Junction temperature	T_j	max.	150 $^\circ\text{C}$
Transfer admittance at $f = 1\text{ kHz}$ $I_D = 10\text{ mA}; V_{DS} = 10\text{ V}; +V_{G2-S} = 4\text{ V}$	$ y_{fs} $	typ.	14 mS
Input capacitance at gate 1; $f = 1\text{ MHz}$ $I_D = 10\text{ mA}; V_{DS} = 10\text{ V}; +V_{G2-S} = 4\text{ V}$	C_{ig1-s}	typ.	2.1 pF
Feedback capacitance at $f = 1\text{ MHz}$ $I_D = 10\text{ mA}; V_{DS} = 10\text{ V}; +V_{G2-S} = 4\text{ V}$	C_{rs}	typ.	20 fF
Noise figure at optimum source admittance $I_D = 10\text{ mA}; V_{DS} = 10\text{ V}; +V_{G2-S} = 4\text{ V}; f = 200\text{ MHz}$	F	typ.	0.7 dB

MECHANICAL DATA

Fig.1 SOT103.

Dimensions in mm

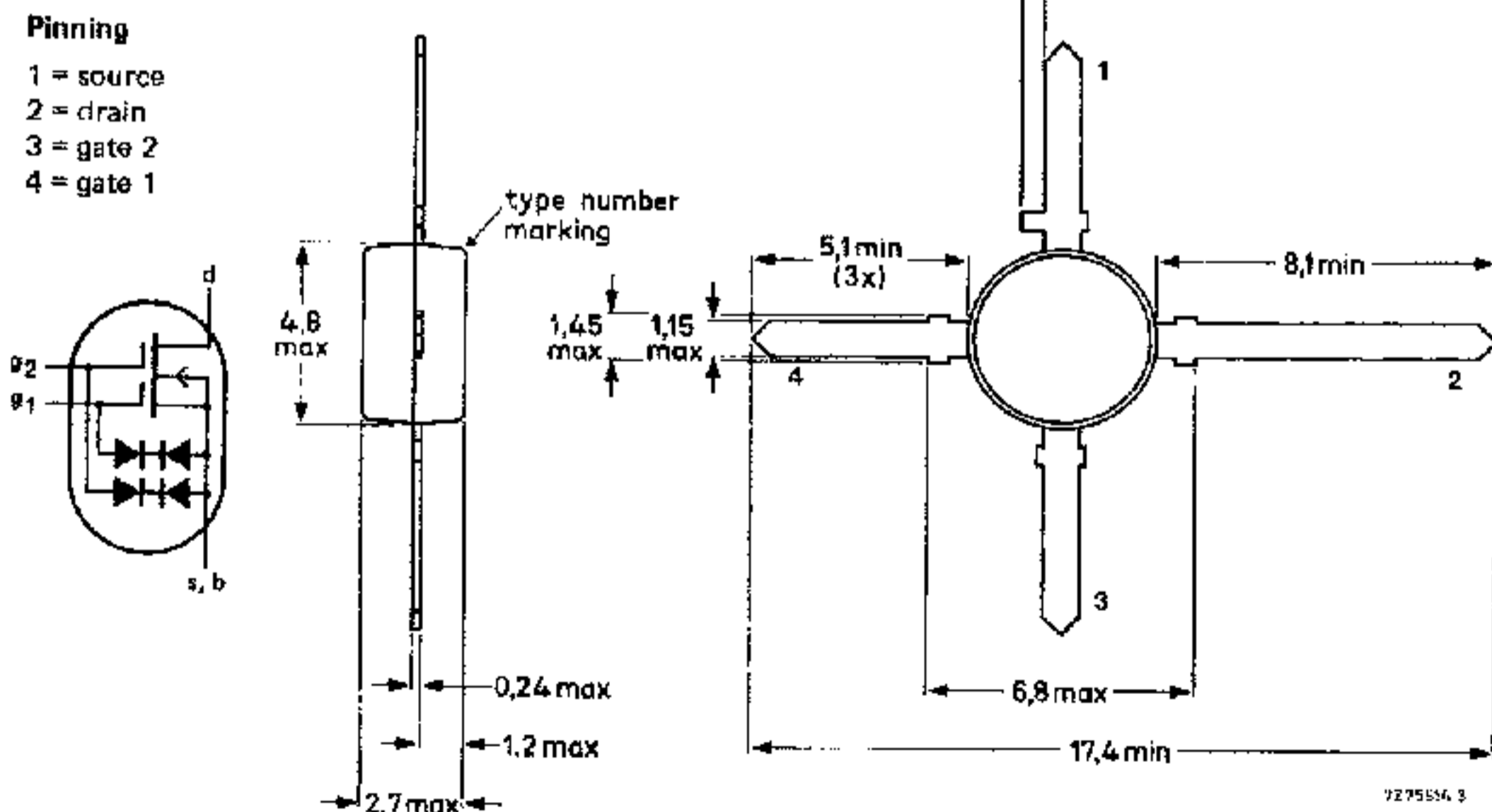



LittleDiode supplies new, hard to find or obsolete electronic components and semiconductors all over the world.

With over two million different components listed you are sure to find the part you need.

Feel free to visit us today at our online store:

LittleDiode.com

Looking forward to providing you with the best possible service.