

High-Speed Drivers with Dual DPST JFET Switches

Features

- Constant On-Resistance Over Entire Analog Range
- Low Leakage
- Low Crosstalk
- Break-Before-Make Switching
- Rad Hardness

Benefits

- Low Distortion
- Eliminates Large Signal Errors
- High Precision
- Improved Channel Isolation
- Eliminates Inadvertent Shorting Between Channels
- Fault Protection

Applications

- Audio Switching
- Precision Switching
- Video Switching
- Video Routing
- Sample/Hold
- Aerospace

Description

The DG183/184/185 are precision dual double-pole, single-throw (DPST) analog switches designed to provide accurate switching of video and audio signals. This series is ideally suited for applications requiring a constant on-resistance over the entire analog range.

The major difference in the devices is the on-resistance (DG183—10 Ω, DG184—30 Ω, DG185—75 Ω). Reduced errors are achieved through low leakage current ($I_{D(on)}$ < 2 nA). Applications which benefit from the flat JFET

on-resistance include audio switching, video switching, and data acquisition.

To achieve fast and accurate switch performance, each device comprises four n-channel JFET transistors and a TTL compatible bipolar driver. In the on state, each switch conducts current equally well in either direction. In the off condition, the switches will block up to 20 V peak-to-peak, with feedthrough of less than -60 dB at 10 MHz.

Functional Block Diagram and Pin Configuration

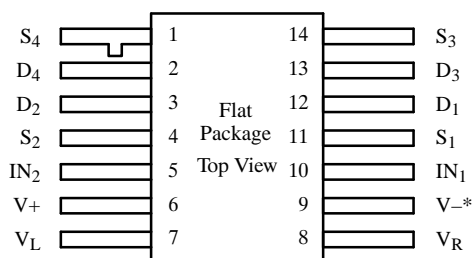
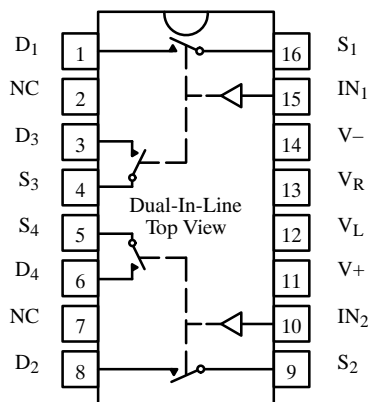

Refer to JAN38510 Information, Military Section
*Common to Substrate and Case

Truth Table

Logic	Switch
0	OFF
1	ON

Logic "0" ≤ 0.8 V
Logic "1" ≥ 2.0 V

Updates to this data sheet may be obtained via facsimile by calling Siliconix FaxBack, 1-408-970-5600. Please request FaxBack document #70032.

Ordering Information

Temp Range	Package	Part Number
-25 to 85°C	16-Pin Sidebrazed	DG183BP
		DG184BP
-55 to 125°C	16-Pin Sidebrazed	DG183AP/883
		DG184AP/883, JM38510/11103BEA
		DG185AP/883, JM38510/11104BEA
	14-Pin Flat Pack	JM38510/11103BXA
		JM38510/11104BXA

Absolute Maximum Ratings

V ₊ to V ₋	36 V	Current (S or D) DG184, DG185	30 mA
V ₊ to V _D	33 V	Current (All Other Pins)	30 mA
V _D to V ₋	33 V	Storage Temperature	-65 to 150°C
V _D to V _D	±22 V	Power Dissipation ^a	
V _L to V ₋	36 V	16-Pin Sidebrazed ^b	900 mW
V _L to V _{IN}	8 V	14-Pin Flat Pack ^c	900 mW
V _L to V _R	8 V		
V _{IN} to V _R	8 V		
V _R to V ₋	27 V	Notes:	
V _R to V _{IN}	2 V	a. All leads welded or soldered to PC Board.	
Current (S or D) DG183	200 mA	b. Derate 12 mW/°C above 75°C	
		c. Derate 10 mW/°C above 75°C	

Schematic Diagram (Typical Channel)

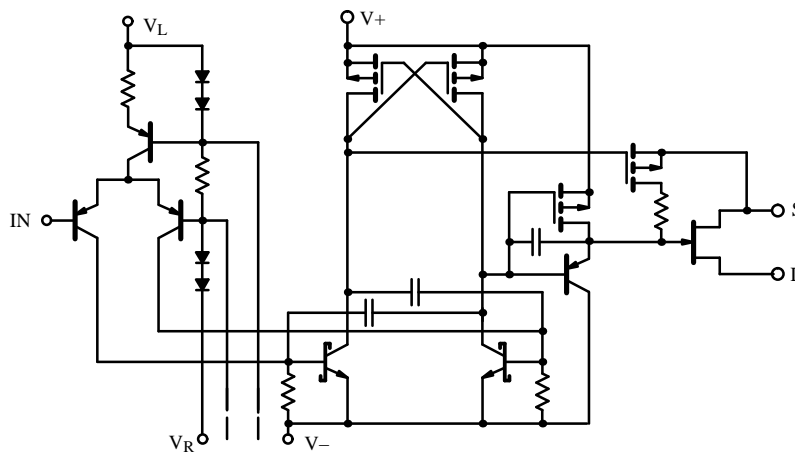

Figure 1.

Specifications^a for DG183

Parameter	Symbol	Test Conditions Unless Otherwise Specified $V_+ = 15\text{ V}$, $V_- = -15\text{ V}$, $V_L = 5\text{ V}$ $V_R = 0\text{ V}$, $V_{IN} = 0.8\text{ V}$ or 2 V^f		Temp ^b	Typ ^c	A Suffix -55 to 125°C		B Suffix -25 to 85°C		Unit
						Min ^d	Max ^d	Min ^d	Max ^d	
Analog Switch										
Analog Signal Range ^e	V_{ANALOG}			Full		-7.5	15	-7.5	15	V
Drain-Source On-Resistance	$r_{DS(on)}$		$I_S = -10\text{ mA}$, $V_D = -7.5\text{ V}$	Room Full	7.5		10 20		15 25	Ω
Source Off Leakage Current	$I_{S(off)}$		$V_S = \pm 10\text{ V}$, $V_D = \mp 10\text{ V}$ $V_+ = 10\text{ V}$, $V_- = -20\text{ V}$	Room Hot	0.05		10 1000		15 300	nA
			$V_S = \pm 7.5\text{ V}$, $V_D = \mp 7.5\text{ V}$	Room Hot	0.05		10 1000		15 300	
Drain Off Leakage Current	$I_{D(off)}$		$V_S = \pm 10\text{ V}$, $V_D = \mp 10\text{ V}$ $V_+ = 10\text{ V}$, $V_- = -20\text{ V}$	Room Hot	0.04		10 1000		15 300	
			$V_S = \pm 7.5\text{ V}$, $V_D = \mp 7.5\text{ V}$	Room Hot	0.03		10 1000		15 300	
Channel On Leakage Current	$I_{D(on)}$		$V_D = V_S = \pm 7.5\text{ V}$	Room Hot	-0.1	-2 -200		-10 -200		
Saturation Drain Current	I_{DSS}		2 ms Pulse Duration	Room	300					mA
Digital Input										
Input Current with Input Voltage High	I_{INH}		$V_{IN} = 5\text{ V}$	Room Hot	<0.01		10 20		10 20	μA
Input Current with Input Voltage Low	I_{INL}		$V_{IN} = 0\text{ V}$	Full	-30	-250		-250		
Dynamic Characteristics										
Turn-On Time	t_{on}	See Switching Time Test Circuit		Room	240		400		600	ns
Turn-Off Time	t_{off}			Room	140		200		220	
Source-Off Capacitance	$C_{S(off)}$	f = 1 MHz	$V_S = -5\text{ V}$, $I_D = 0$	Room	21					pF
Drain-Off Capacitance	$C_{D(off)}$		$V_D = -5\text{ V}$, $I_S = 0$	Room	17					
Channel-On Capacitance	$C_{D(on)}$		$V_D = V_S = 0\text{ V}$	Room	17					
Off Isolation	OIRR		f = 1 MHz, $R_L = 75\ \Omega$	Room	>55					dB
Power Supplies										
Positive Supply Current	I_+	$V_{IN} = 0\text{ V}$, or 5 V		Room	0.6		1.5		1.5	mA
Negative Supply Current	I_-			Room	-2.7	-5		-5		
Logic Supply Current	I_L			Room	3.1		4.5		4.5	
Reference Supply Current	I_R			Room	-1	-2		-2		

Notes:

- Refer to PROCESS OPTION FLOWCHART .
- Room = 25°C, Full = as determined by the operating temperature suffix.
- Typical values are for DESIGN AID ONLY, not guaranteed nor subject to production testing.
- The algebraic convention whereby the most negative value is a minimum and the most positive a maximum, is used in this data sheet.
- Guaranteed by design, not subject to production test.
- V_{IN} = input voltage to perform proper function.

Specifications^a for DG184

Parameter	Symbol	Test Conditions Unless Otherwise Specified $V_+ = 15\text{ V}$, $V_- = -15\text{ V}$, $V_L = 5\text{ V}$ $V_R = 0\text{ V}$, $V_{IN} = 0.8\text{ V}$ or 2 V^f	Temp ^b	Typ ^c	A Suffix -55 to 125°C		B Suffix -25 to 85°C		Unit
					Min ^d	Max ^d	Min ^d	Max ^d	
Analog Switch									
Analog Signal Range ^e	V_{ANALOG}		Full		-7.5	15	-7.5	15	V
Drain-Source On-Resistance	$r_{DS(on)}$	$I_S = -10\text{ mA}$, $V_D = -7.5\text{ V}$	Room Full	22		30 60		50 75	Ω
Source Off Leakage Current	$I_{S(off)}$	$V_S = \pm 10\text{ V}$, $V_D = \mp 10\text{ V}$ $V_+ = 10\text{ V}$, $V_- = -20\text{ V}$	Room Hot	0.06		1 100		5 100	nA
		$V_S = \pm 7.5\text{ V}$, $V_D = \mp 7.5\text{ V}$	Room Hot	0.05		1 100		5 100	
Drain Off Leakage Current	$I_{D(off)}$	$V_S = \pm 10\text{ V}$, $V_D = \mp 10\text{ V}$ $V_+ = 10\text{ V}$, $V_- = -20\text{ V}$	Room Hot	0.4		1 100		5 100	
		$V_S = \pm 7.5\text{ V}$, $V_D = \mp 7.5\text{ V}$	Room Hot	0.3		1 100		5 100	
Channel On Leakage Current	$I_{D(on)}$	$V_D = V_S = \pm 7.5\text{ V}$	Room Hot	-0.02	-2 -200		-10 -200		
Digital Input									
Input Current with Input Voltage High	I_{INH}	$V_{IN} = 5\text{ V}$	Room Hot	<0.01		10 20		10 20	μA
Input Current with Input Voltage Low	I_{INL}	$V_{IN} = 0\text{ V}$	Full	-30	-250		-250		
Dynamic Characteristics									
Turn-On Time	t_{on}	See Switching Time Test Circuit	Room	85		150		180	ns
Turn-Off Time	t_{off}		Room	95		130		150	
Source-Off Capacitance	$C_{S(off)}$	$f = 1\text{ MHz}$	Room	9					pF
Drain-Off Capacitance	$C_{D(off)}$		$V_S = -5\text{ V}$, $I_D = 0$	Room	6				
Channel-On Capacitance	$C_{D(on)}$		$V_D = -5\text{ V}$, $I_S = 0$	Room	14				
Off Isolation	OIRR	$f = 1\text{ MHz}$, $R_L = 75\ \Omega$	Room	>50					dB
Power Supplies									
Positive Supply Current	I_+	$V_{IN} = 0\text{ V}$, or 5 V	Room	0.6		3		3	mA
Negative Supply Current	I_-		Room	-2.7	-5.5		-5.5		
Logic Supply Current	I_L		Room	3.1		4.5		4.5	
Reference Supply Current	I_R		Room	-1	-2		-2		

Notes:

- Refer to PROCESS OPTION FLOWCHART .
- Room = 25°C, Full = as determined by the operating temperature suffix.
- Typical values are for DESIGN AID ONLY, not guaranteed nor subject to production testing.
- The algebraic convention whereby the most negative value is a minimum and the most positive a maximum, is used in this data sheet.
- Guaranteed by design, not subject to production test.
- V_{IN} = input voltage to perform proper function.

Specifications^a for DG185

Parameter	Symbol	Test Conditions Unless Otherwise Specified $V_+ = 15\text{ V}$, $V_- = -15\text{ V}$, $V_L = 5\text{ V}$ $V_R = 0\text{ V}$, $V_{IN} = 0.8\text{ V}$ or 2 V^f	Temp ^b	Typ ^c	A Suffix -55 to 125°C		B Suffix -25 to 85°C		Unit
					Min ^d	Max ^d	Min ^d	Max ^d	
Analog Switch									
Analog Signal Range ^e	V_{ANALOG}		Full		-10	15	-10	15	V
Drain-Source On-Resistance	$r_{DS(on)}$	$I_S = -10\text{ mA}$, $V_D = -7.5\text{ V}$	Room Full	35		75 150		100 150	Ω
Source Off Leakage Current	$I_{S(off)}$	$V_S = \pm 10\text{ V}$, $V_D = \mp 10\text{ V}$ $V_+ = 10\text{ V}$, $V_- = -20\text{ V}$	Room Hot	0.05		1 100		5 100	nA
		$V_S = \pm 10\text{ V}$, $V_D = \mp 10\text{ V}$	Room Hot	0.07		1 100		5 100	
Drain Off Leakage Current	$I_{D(off)}$	$V_S = \pm 10\text{ V}$, $V_D = \mp 10\text{ V}$ $V_+ = 10\text{ V}$, $V_- = -20\text{ V}$	Room Hot	0.4		1 100		5 100	
		$V_S = \pm 10\text{ V}$, $V_D = \mp 10\text{ V}$	Room Hot	0.3		1 100		5 100	
Channel On Leakage Current	$I_{D(on)}$	$V_D = V_S = \pm 10\text{ V}$	Room Hot	-0.03	-2 -200		-10 -200		
Digital Input									
Input Current with Input Voltage High	I_{INH}	$V_{IN} = 5\text{ V}$	Room Hot	<0.01		10 20		10 20	μA
Input Current with Input Voltage Low	I_{INL}	$V_{IN} = 0\text{ V}$	Full	-30	-250		-250		
Dynamic Characteristics									
Turn-On Time	t_{on}	See Switching Time Test Circuit	Room	120		250		300	ns
Turn-Off Time	t_{off}		Room	100		130		150	
Source-Off Capacitance	$C_{S(off)}$	$f = 1\text{ MHz}$	Room	9					pF
Drain-Off Capacitance	$C_{D(off)}$		$V_S = -5\text{ V}$, $I_D = 0$	Room	6				
Channel-On Capacitance	$C_{D(on)}$		$V_D = -5\text{ V}$, $I_S = 0$	Room	14				
Off Isolation	OIRR	$f = 1\text{ MHz}$, $R_L = 75\ \Omega$	Room	>50					dB
Power Supplies									
Positive Supply Current	I_+	$V_{IN} = 0\text{ V}$, or 5 V	Room	0.6		3		3	mA
Negative Supply Current	I_-		Room	-2.7	-5.5		-5.5		
Logic Supply Current	I_L		Room	3.1		4.5		4.5	
Reference Supply Current	I_R		Room	-1	-2		-2		

Notes:

- Refer to PROCESS OPTION FLOWCHART .
- Room = 25°C, Full = as determined by the operating temperature suffix.
- Typical values are for DESIGN AID ONLY, not guaranteed nor subject to production testing.
- The algebraic convention whereby the most negative value is a minimum and the most positive a maximum, is used in this data sheet.
- Guaranteed by design, not subject to production test.
- V_{IN} = input voltage to perform proper function.

Typical Characteristics

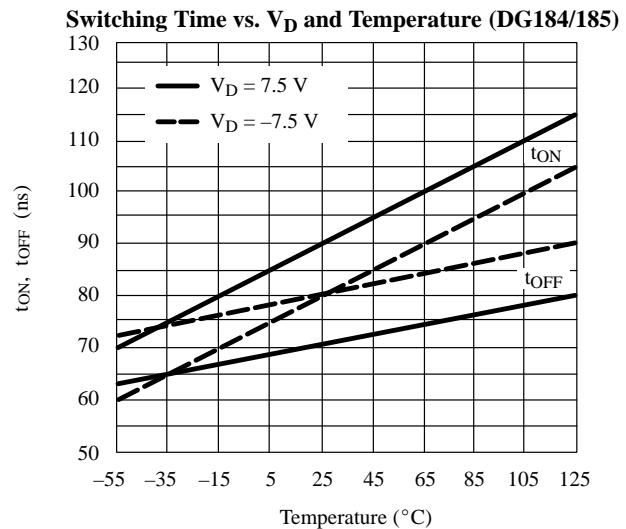
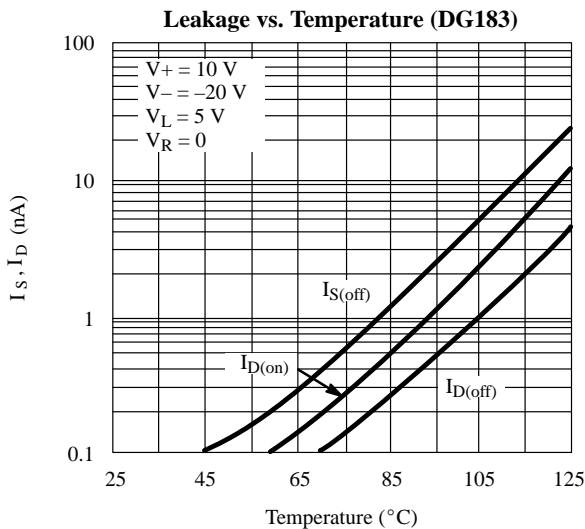
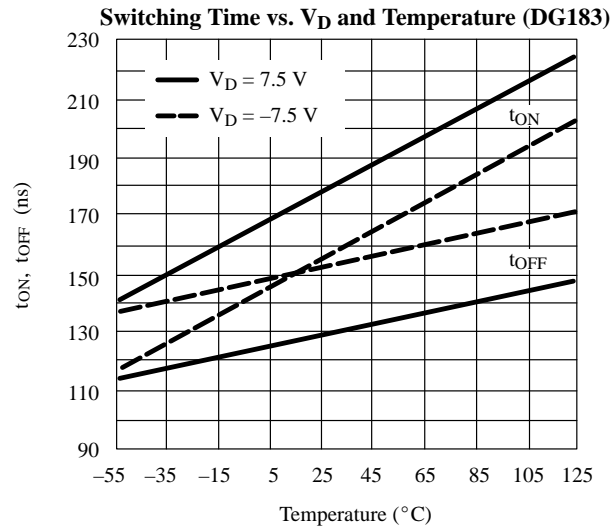
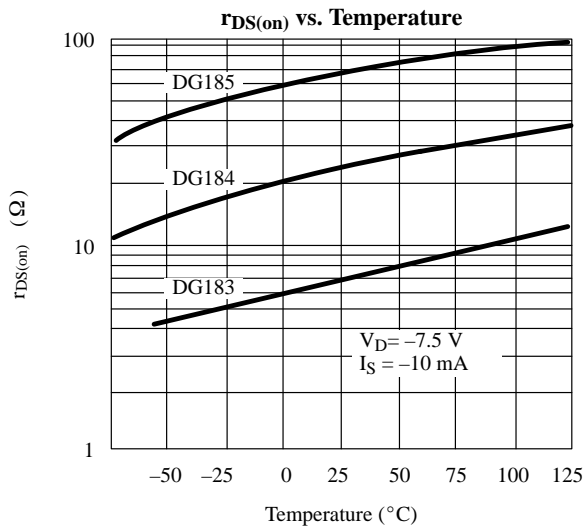
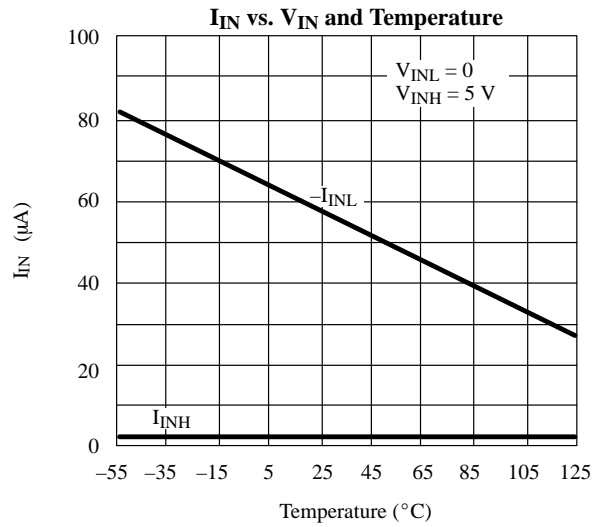
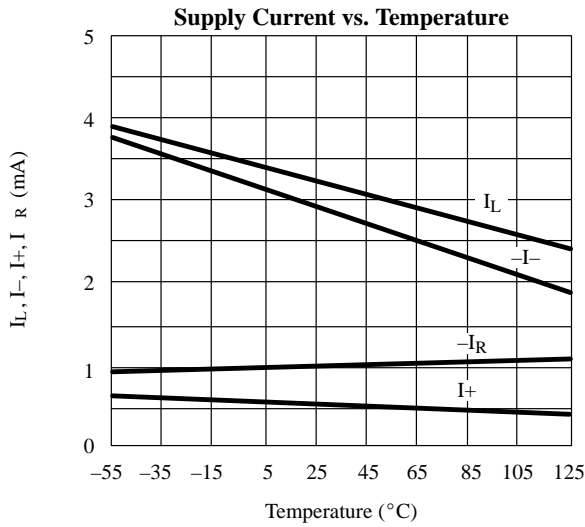

Typical Characteristics (Cont'd)

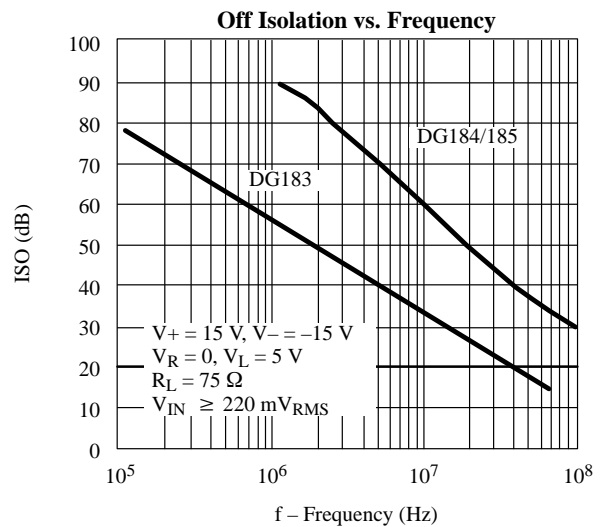
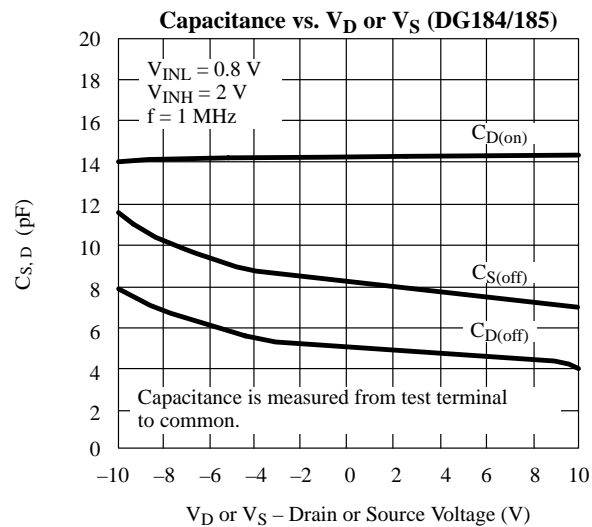
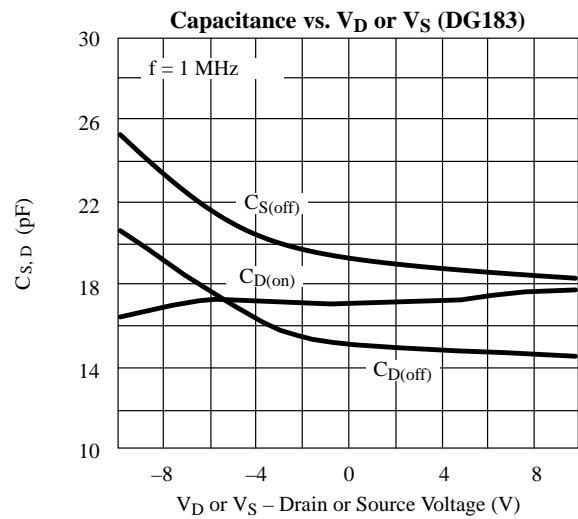
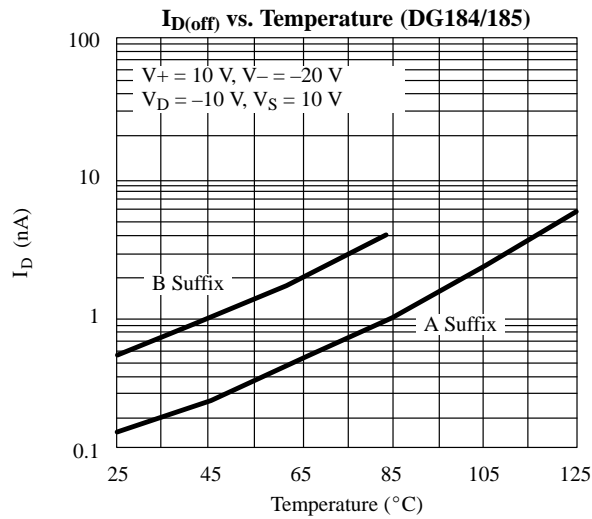

Test Circuits

Feedthrough due to charge injection may result in spikes at the leading and trailing edge of the output waveform.

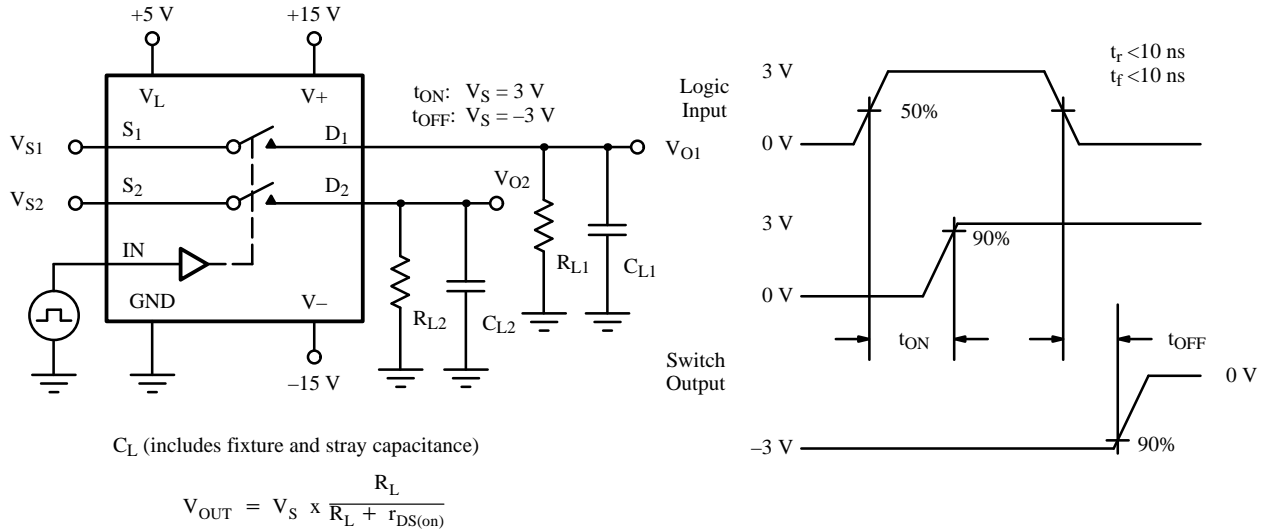

Figure 2. Switching Time

Application Hints^a

Switch	V+ Positive Supply Voltage (V)	V- Negative Supply Voltage (V)	V _L Logic Supply Voltage (V)	V _R Reference Supply Voltage (V)	V _{IN} Logic Input Voltage V _{INH(min)} /V _{INL(max)} (V)	V _S Analog Voltage Range (V)
DG183	15 ^b	-15	5	GND	2.0/0.8	-7.5 to 15
DG184	10	-20	5	GND	2.0/0.8	-12.5 to 10
	12	-12	5	GND	2.0/0.8	-4.5 to 12
DG185	15 ^b	-15	5	GND	2.0/0.8	-10 to 15
	10	-20	5	GND	2.0/0.8	-15 to 10
	12	-12	5	GND	2.0/0.8	-7 to 12

Notes:

- Application Hints are for DESIGN AID ONLY, not guaranteed and not subject to production testing.
- Electrical Parameter Chart based on V+ = 15 V, V_L = 5 V, V_R = GND.

This datasheet has been downloaded from:

www.DatasheetCatalog.com

Datasheets for electronic components.



LittleDiode supplies new, hard to find or obsolete electronic components and semiconductors all over the world.

With over two million different components listed you are sure to find the part you need.

Feel free to visit us today at our online store:

LittleDiode.com

Looking forward to providing you with the best possible service.