

December 1993

CMOS Dual/Quad SPST Analog Switches

Features

- Switches Greater than $28V_{p,p}$ Signals with ± 15 Supplies
- Break-Before-Make Switching t_{OFF} 250ns, t_{ON} 700ns Typical
- TTL, DTL, CMOS, PMOS Compatible
- Non-Latching with Supply Turn-Off
- Complete Monolithic Construction
- Industry Standard (DG200, DG201)

Applications

- Data Acquisition
- Sample and Hold Circuits
- Operational Amplifier Gain Switching Networks

Description

The DG200 and DG201 solid state analog gates are designed using an improved, high voltage CMOS monolithic technology. They provide ease-of-use and performance advantages not previously available from solid state switches. Destructive latch-up of solid state analog gates has been eliminated by Harris's CMOS technology.

The DG200 and DG201 are completely specification and pinout compatible with the industry standard devices.

Ordering Information

PART NUMBER	TEMPERATURE	PACKAGE
DG200AA	-55°C to +125°C	10 Pin Metal Can
DG200AK	-55°C to +125°C	14 Lead Ceramic DIP
DG200BA	-25°C to +85°C	10 Pin Metal Can
DG200BK	-25°C to +85°C	14 Lead Ceramic DIP
DG200CJ	0°C to +70°C	14 Lead Plastic DIP
DG200AA/883B	-55°C to +125°C	10 Pin Metal Can
DG200AK/883B	-55°C to +125°C	14 Lead Ceramic DIP
DG201AK	-55°C to +125°C	16 Lead Ceramic DIP
DG201BK	-25°C to +85°C	16 Lead Ceramic DIP
DG201CJ	0°C to +70°C	16 Lead Plastic DIP
DG201AK/883B	-55°C to +125°C	16 Lead Ceramic DIP

Pinouts

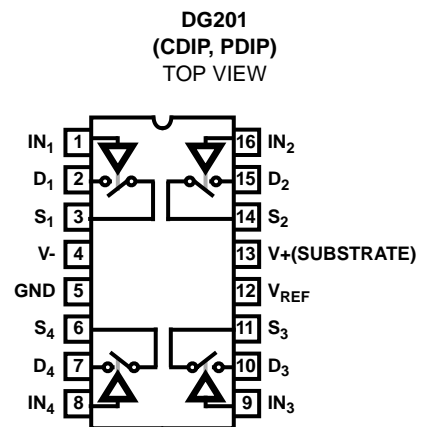
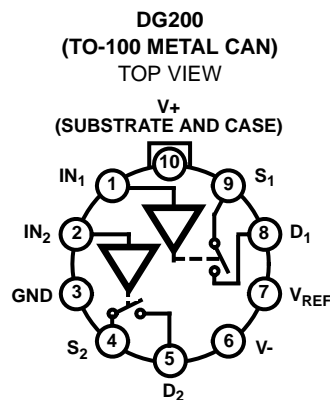
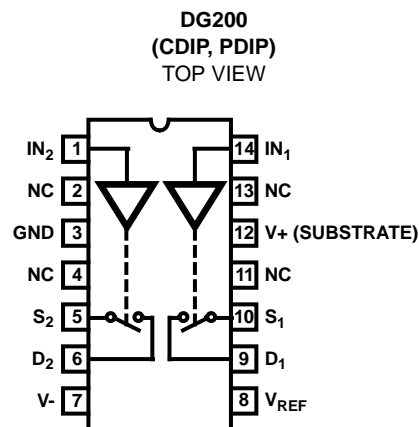

DG200, DG201

Schematic Diagram ($1/2$ DG200, $1/4$ DG201)

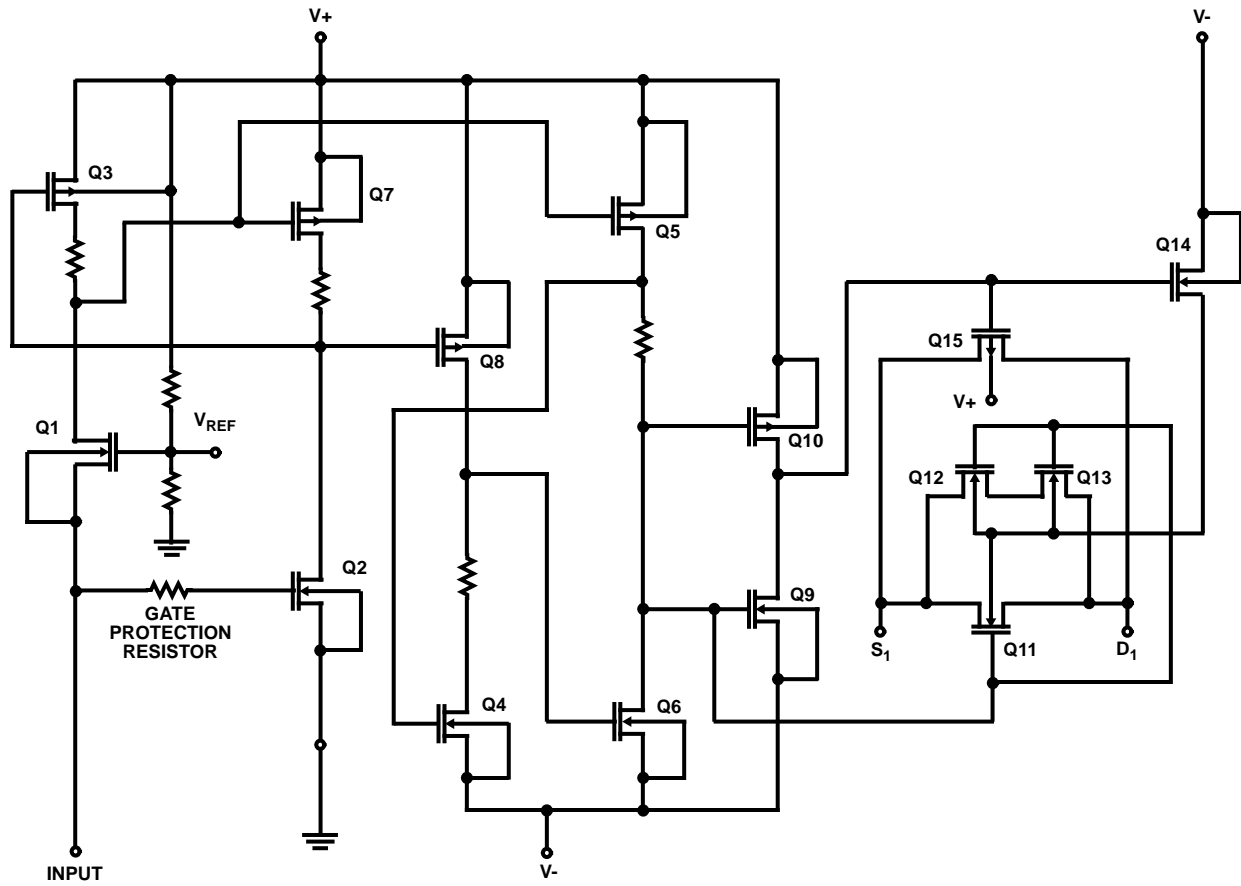

Functional Diagram

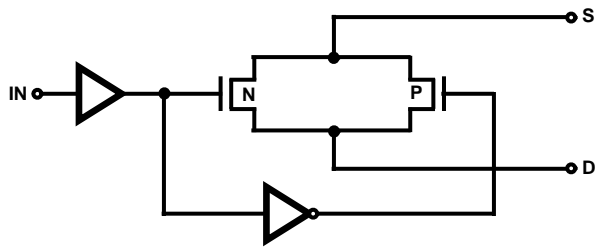

DG200, DG201 SWITCH CELL

Specifications DG200

Absolute Maximum Ratings

V+, V-	<36V
V+ - V _D	<30V
V _D - V-	<30V
V _D - V _S	<28V
V _{IN} - GND	<20V
Storage Temperature Range	-65°C to +150°C
Lead Temperature (Soldering 10s)	+300°C

Thermal Information

Thermal Resistance	θ_{JA}	θ_{JC}
Ceramic DIP Package	95°C/W	24°C/W
Plastic DIP Package	100°C/W	-
Metal Can Package	136°C/W	65°C/W
Operating Temperature Range		
"A" Suffix	-55°C to +125°C	
"B" Suffix	-25°C to +85°C	
"C" Suffix	0°C to +70°C	

CAUTION: Stresses above those listed in "Absolute Maximum Ratings" may cause permanent damage to the device. This is a stress only rating and operation of the device at these or any other conditions above those indicated in the operational sections of this specification is not implied.

Electrical Specifications (T_A = +25°C, V₊ = +15V, V₋ = -15V)

PARAMETER	TEST CONDITIONS	MILITARY			COMMERCIAL / INDUSTRIAL			UNITS
		-55°C	+25°C	+125°C	0°C TO -25°C	+25°C	+70°C TO +85°C	
Input Logic Current, I _{IN(ON)}	V _{IN} = 0.8V (Notes 2, 3)	±10	±1	±10	-	±10	±10	μA
Input Logic Current, I _{IN(OFF)}	V _{IN} = 2.4V (Notes 2, 3)	±10	±1	±10	-	±10	±10	μA
Drain-Source On Resistance, r _{DS(ON)}	I _S = 10mA, V _{ANALOG} = ±10V	70	70	100	80	80	100	Ω
Channel-to-Channel r _{DS(ON)} Match, r _{DS(ON)}		-	25 (Typ)	-	-	30 (Typ)	-	Ω
Minimum Analog Signal Handling Capability, V _{ANALOG}		-	±15V	-	-	±15V	-	V
Switch OFF Leakage Current, I _{D(OFF)}	V _{ANALOG} = -14V to +14V	-	±2	100	-	±5	100	nA
Switch OFF Leakage Current, I _{S(OFF)}	V _{ANALOG} = -14V to +14V	-	±2	100	-	±5	100	nA
Switch ON Leakage Current, I _{D(ON)} + I _{S(ON)}	V _D = V _S = -14V to +14V	-	±2	200	-	±10	200	nA
Switch "ON" Time (Note 1), t _{ON}	R _L = 1kΩ, V _{ANALOG} = -10V to +10V (Figure 5)	-	1.0	-	-	1.0	-	μs
Switch "OFF" Time, t _{OFF}	R _L = 1kΩ, V _{ANALOG} = -10V to +10V (Figure 5)	-	0.5	-	-	0.5	-	μs
Charge Injection, Q _(INJ.)	Figure 6	-	15 (Typ)	-	-	20 (Typ)	-	mV
Minimum Off Isolation Rejection Ratio, OIRR	f = 1MHz, R _L = 100Ω, C _L ≤ 5pF (Figure 7, Note 1)	-	54 (Typ)	-	-	50 (Typ)	-	dB
+Power Supply Quiescent Current, I _{V1}	V _{IN} = 0V or V _{IN} = 5V	1000	1000	2000	1000	1000	2000	μA
-Power Supply Quiescent Current, I _{V2}		1000	1000	2000	1000	1000	2000	μA
Minimum Channel to Channel Cross Coupling Rejection Ratio, CCRR	One Channel Off	-	54 (Typ)	-	-	50 (Typ)	-	dB

NOTES:

1. Pull Down Resistor must be ≤ 2kΩ.
2. Typical values are for design aid only, not guaranteed and not subject to production testing.
3. All channels are turned off by high "1" logic inputs and all channels are turned on by low "0" inputs; however 0.8V to 2.4V describes the minimum range for switching properly. Peak input current required for transition is typically -120μA.

Specifications DG201

Absolute Maximum Ratings

V+ to V-	<36V
V+ to V _D	<30V
V _D to V-	<30V
V _D to V _S	<28V
V _{REF} to V-	<33V
V _{REF} to V _{IN}	<30V
V _{REF} to GND	<20V
V _{IN} to GND	<20V
Current (Any Terminal)	<30mA
Storage Temperature Range	-65°C to +150°C
Lead Temperature (Soldering 10s)	+300°C

Thermal Information

Thermal Resistance	θ_{JA}	θ_{JC}
Ceramic DIP Package	80°C/W	24°C/W
Plastic DIP Package	145°C/W	-
Operating Temperature Range		
"A" Suffix	-55°C to +125°C	
"B" Suffix	-25°C to +85°C	
"C" Suffix	0°C to +70°C	

CAUTION: Stresses above those listed in "Absolute Maximum Ratings" may cause permanent damage to the device. This is a stress only rating and operation of the device at these or any other conditions above those indicated in the operational sections of this specification is not implied.

Electrical Specifications (T_A = +25°C, V+ = +15V, V- = -15V)

PARAMETER	TEST CONDITIONS	MILITARY			COMMERCIAL / INDUSTRIAL			UNITS
		-55°C	+25°C	+125°C	0°C TO -25°C	+25°C	+70°C TO +85°C	
Input Logic Current, I _{IN(ON)}	V _{IN} = 0.8V (Note 1)	10	±1	10	±1	±1	10	μA
Input Logic Current, I _{N(OFF)}	V _{IN} = 2.4V (Note 1)	10	±1	10	±1	±1	10	μA
Drain-Source On Resistance, r _{DS(ON)}	I _S = 10mA, V _{ANALOG} = ±10V	80	80	125	100	100	125	Ω
Channel-to-Channel r _{DS(ON)} Match, r _{DS(ON)}		-	25 (Typ)	-	-	30 (Typ)	-	Ω
Minimum Analog Signal Handling Capability, V _{ANALOG}		-	±15 (Typ)	-	-	±15 (Typ)	-	V
Switch OFF Leakage Current, I _{D(OFF)}	V _{ANALOG} = -14V to +14V	-	±1	100	-	±5	100	nA
Switch OFF Leakage Current, I _{S(OFF)}	V _{ANALOG} = -14V to +14V	-	±1	100	-	±5	100	nA
Switch ON Leakage Current, I _{D(ON)} + I _{S(ON)}	V _D = V _S = -14V to +14V	-	±2	200	-	±5	200	nA
Switch "ON" Time (Note 2), t _{ON}	R _L = 1kΩ, V _{ANALOG} = -10V to +10V (Figure 5)	-	1.0	-	-	1.0	-	μs
Switch "OFF" Time (Note 2), t _{OFF}	R _L = 1kΩ, V _{ANALOG} = -10V to +10V (Figure 5)	-	0.5	-	-	0.5	-	μs
Charge Injection, Q _(INJ.)	Figure 6	-	15 (Typ)	-	-	20 (Typ)	-	mV
Minimum Off Isolation Rejection Ratio, OIRR	f = 1MHz, R _L = 100Ω, C _L ≤ 5pF, (Figure 7)	-	54 (Typ)	-	-	50 (Typ)	-	dB
+Power Supply Quiescent Current, I _{+Q}	V _{IN} = 0V or V _{IN} = 5V	2000	1000	2000	2000	1000	2000	μA
-Power Supply Quiescent Current, I _{-Q}		2000	1000	2000	2000	1000	2000	μA
Minimum Channel to Channel Cross Coupling Rejection Ratio, CCRR	One Channel Off	-	54 (Typ)	-	-	50 (Typ)	-	dB

NOTES:

- Typical values are for design aid only, not guaranteed and not subject to production testing.
- All channels are turned off by high "1" logic inputs and all channels are turned on by low "0" inputs; however 0.8V to 2.4V describes the minimum range for switching properly. Peak input current required for transition is typically -120μA.

Performance Curves

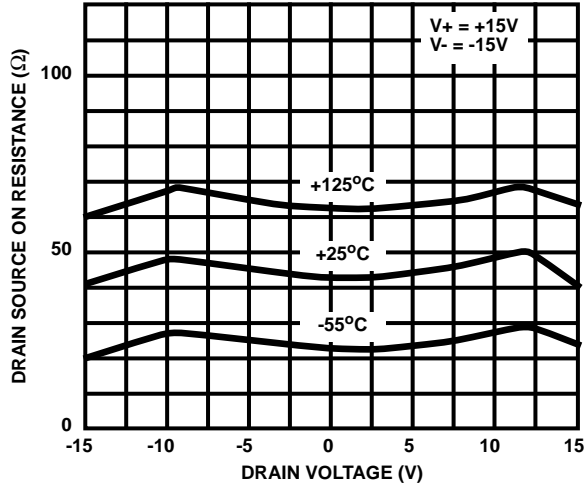

FIGURE 1. $R_{DS(ON)}$ vs V_D AND TEMPERATURE

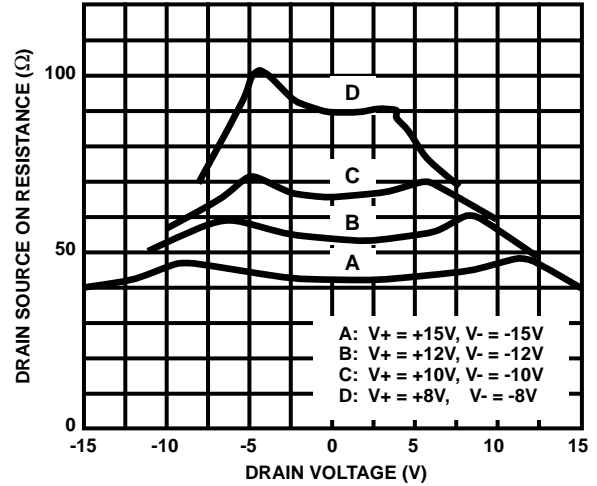

FIGURE 2. $r_{DS(ON)}$ vs V_D AND POWER SUPPLY VOLTAGE

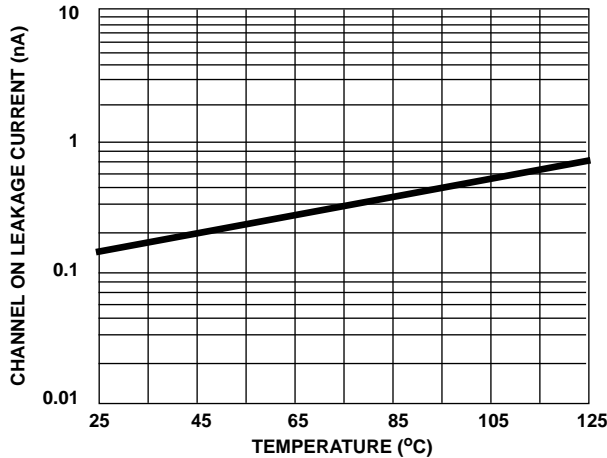

FIGURE 3. $I_{D(ON)}$ vs TEMPERATURE

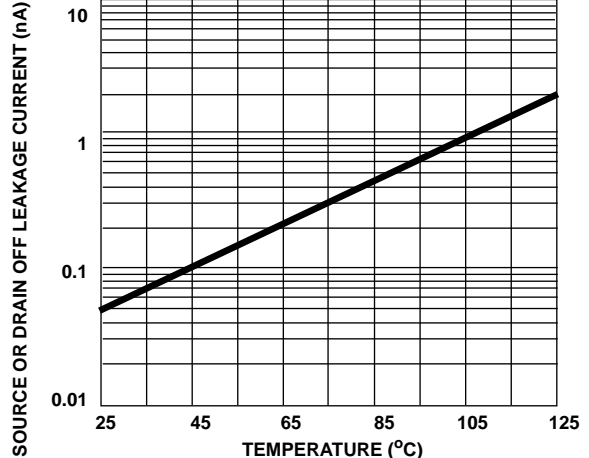

FIGURE 4. $I_{S(OFF)}$ OR $I_{D(OFF)}$ vs TEMPERATURE

Pin Description

DG200 (14 LEAD DIP)		
PIN	SYMBOL	DESCRIPTION
1	IN ₂	Logic control for switch 2
2	NC	No Connection
3	GND	Ground Terminal (Logic Common)
4	NC	No Connection
5	S ₂	Source (input) terminal for switch 2
6	D ₂	Drain (output) terminal for switch 2
7	V-	Negative power supply terminal
8	V _{REF}	Logic reference voltage
9	D ₁	Drain (output) terminal for switch 1
10	S ₁	Source (input) terminal for switch 1
11	NC	No Connection
12	V+	Positive power supply terminal (substrate)
13	NC	No Connection
14	IN ₁	Source (input) terminal for switch 1

DG201 (16 LEAD DIP)		
PIN	SYMBOL	DESCRIPTION
1	IN ₁	Logic control for switch 1
2	D ₁	Drain (output) terminal for switch 1
3	S ₁	Source (input) terminal for switch 1
4	V-	Negative power supply terminal
5	GND	Ground terminal (Logic Common)
6	S ₄	Source (input) terminal for switch 4
7	D ₄	Drain (output) terminal for switch 4
8	IN ₄	Logic control for switch 4
9	IN ₃	Logic control for switch 3
10	D ₃	Drain (output) terminal for switch 3
11	S ₃	Source (input) terminal for switch 3
12	V _{REF}	Logic reference voltage
13	V+	Positive power supply terminal (substrate)
14	S ₂	Source (input) terminal for switch 2
15	D ₂	Drain (output) terminal for switch 2
16	IN ₂	Logic control for switch 2

Test Circuits

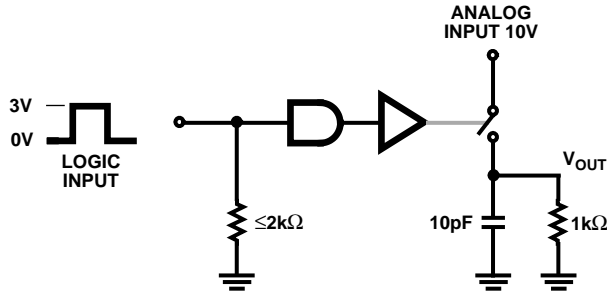

NOTE: All channels are turned off by high "1" logic inputs and all channels are turned on by low "0" inputs; however 0.8V to 2.4V describes the minimum range for switching properly. Peak input current required for transition is typically -120μA.

FIGURE 5.

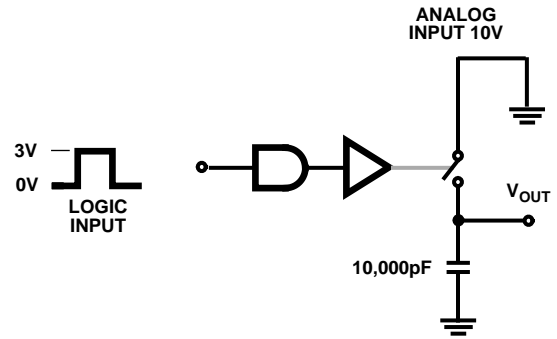
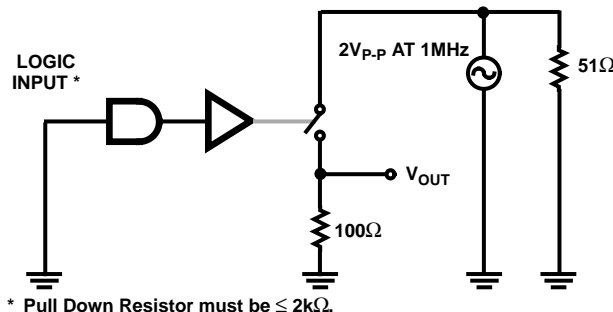

FIGURE 6.



* Pull Down Resistor must be ≤ 2kΩ.

FIGURE 7.

Typical Applications

Using the V_{REF} Terminal

The DG200 and DG201 have an internal voltage divider setting the TTL threshold on the input control lines for V+ equal to +15V. The schematic shown in Figure 8 with nominal resistor values, gives approximately 2.4V on the V_{REF} pin. As the TTL input signal goes from +0.8V to +2.4V, Q1 and Q2 switch states to turn the switch ON and OFF.

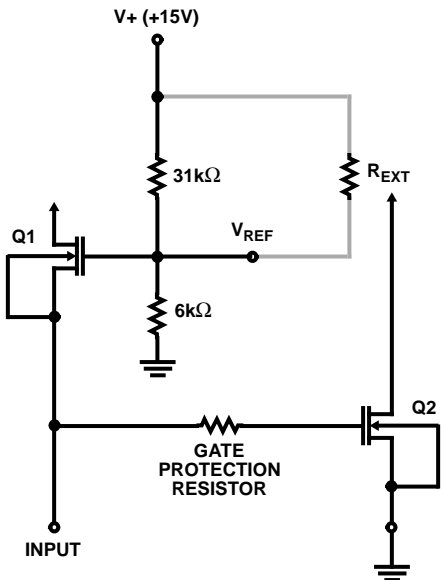

FIGURE 8.

If the power supply voltage is less than +15V, then a resistor must be added between V+ and the V_{REF} pin, to restore +2.4V at V_{REF}. The table shows the value of this resistor for various supply voltages, to maintain TTL compatibility. If CMOS logic levels on a +5V supply are being used, the threshold shifts are less critical, but a separate column of suitable values is given in the table. For logic swings of -5V to +5V, no resistor is needed.

In general, the "low" logic level should be <0.8V to prevent Q1 and Q2 from both being ON together (this will cause incorrect switch function).

TABLE 1.

V+ SUPPLY (V)	TTL RESISTOR (kΩ)	CMOS RESISTOR (kΩ)
+15	-	-
+12	100	-
+10	51	-
+9	(34)	34
+8	(27)	27
+7	18	18

DG200

Metallization Topology

DIE DIMENSIONS:

74 x 77 x 14 ± 1mils

METALLIZATION:

Type: Al

Thickness: 10kÅ ± 1kÅ

GLASSIVATION:

Type: SiO₂/Si₃N₄

SiO₂ Thickness: 7kÅ ± 1.4kÅ

Si₃N₄ Thickness: 8kÅ ± 1.2kÅ

WORST CASE CURRENT DENSITY:

1 x 10⁵ A/cm²

Metallization Mask Layout

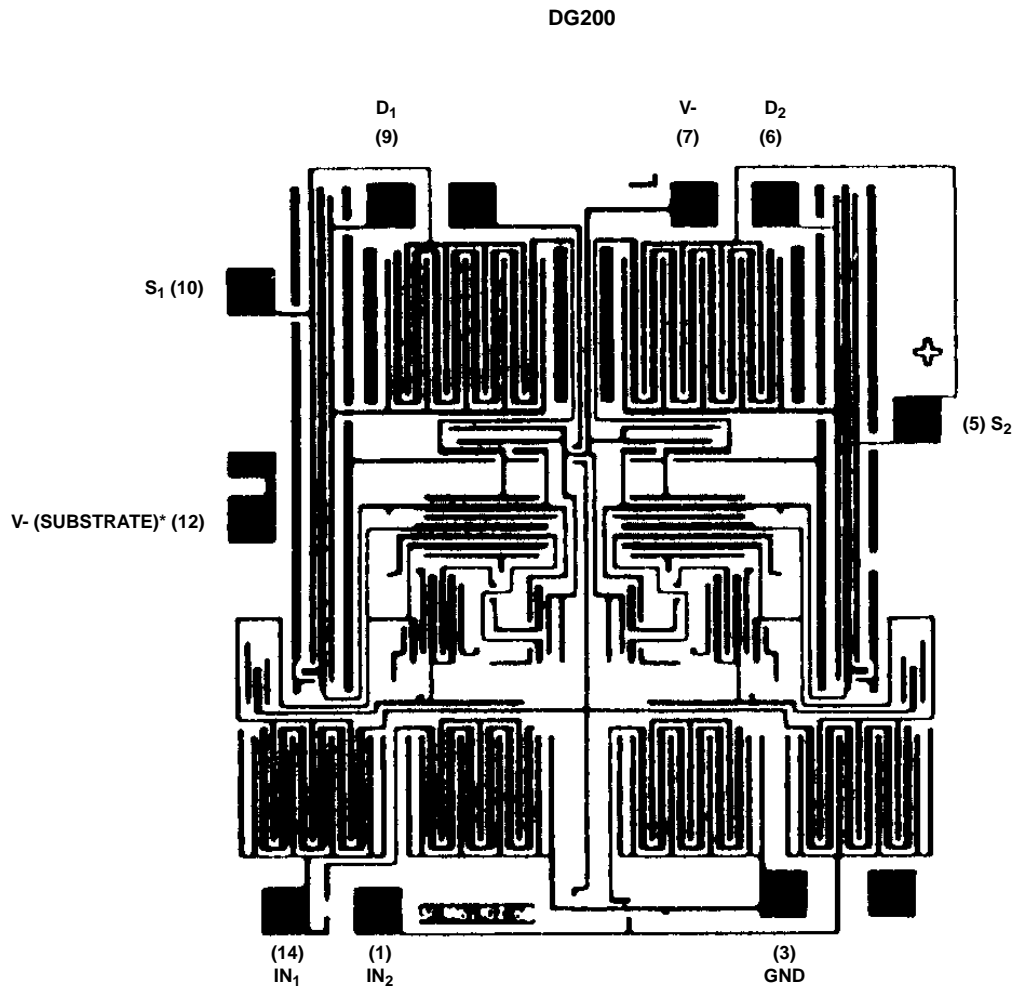

* Backside of Chip is V+

DG201

Metallization Topology

DIE DIMENSIONS:

94 x 101 x 14 ± 1mils

METALLIZATION:

Type: Al

Thickness: 10kÅ ± 1kÅ

GLASSIVATION:

Type: SiO₂/Si₃N₄

SiO₂ Thickness: 7kÅ ± 1.4kÅ

Si₃N₄ Thickness: 8kÅ ± 1.2kÅ

WORST CASE CURRENT DENSITY:

1 x 10⁵ A/cm²

Metallization Mask Layout

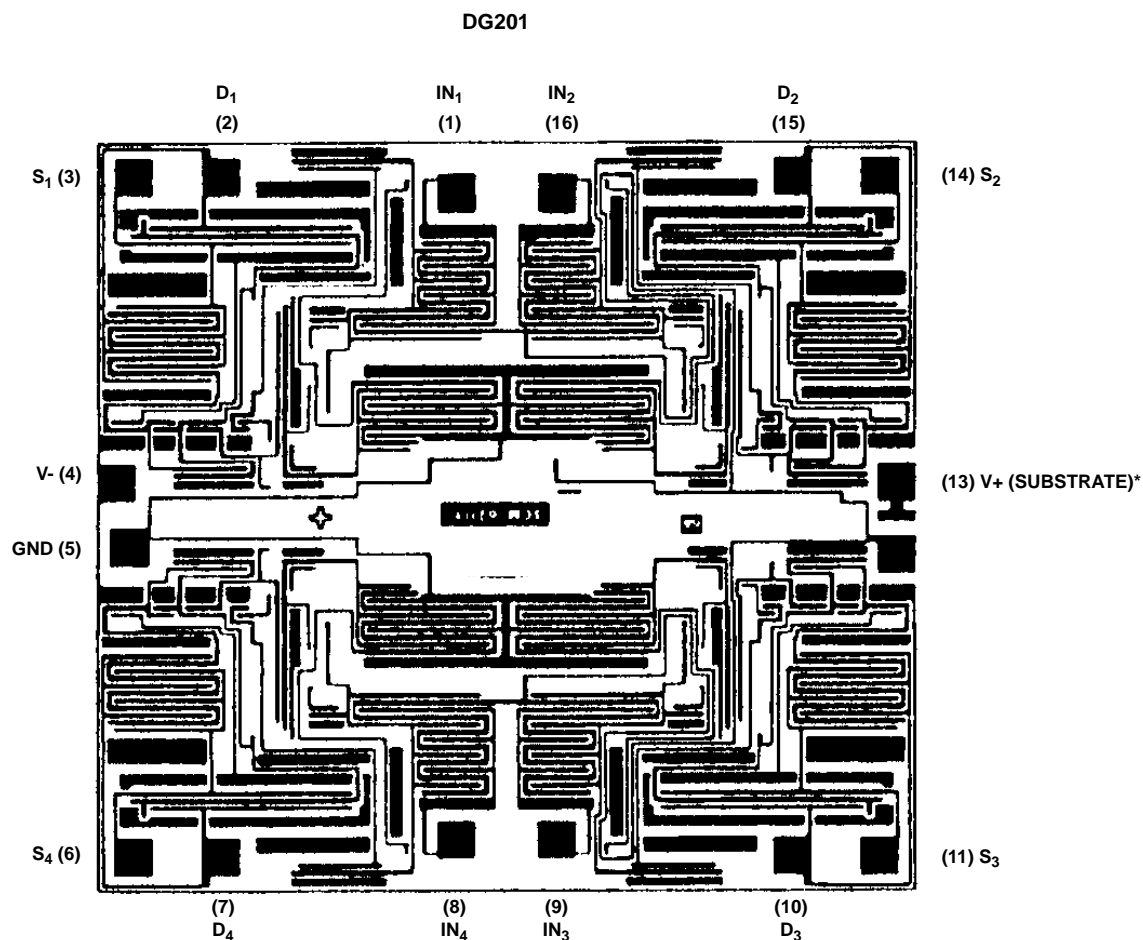

* Backside of Chip is V+

This datasheet has been downloaded from:

www.DatasheetCatalog.com

Datasheets for electronic components.



LittleDiode supplies new, hard to find or obsolete electronic components and semiconductors all over the world.

With over two million different components listed you are sure to find the part you need.

Feel free to visit us today at our online store:

LittleDiode.com

Looking forward to providing you with the best possible service.