

DIODE (ISOLATED MOLD TYPE)

DG20AA



UL;E76102 (M)

DG20AA is a medium power isolated module diode suitable for wide range of industrial and home electronics use. DG20AA is highly reliable by glass passivation.

- $I_{F(AV)} = 20A$, $V_{RRM} = 1600V$
- Tab terminals for easy wiring.

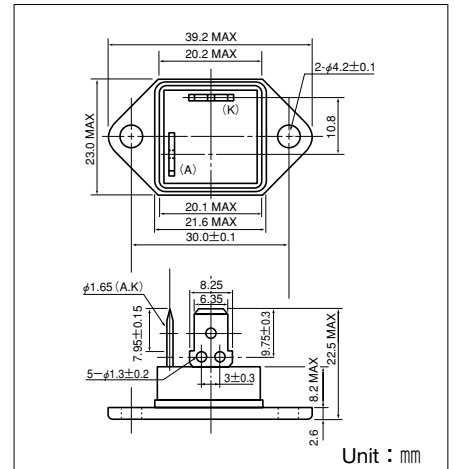

Maximum Ratings

($T_j = 25^\circ C$ unless otherwise specified)

Symbol	Item	Ratings				Unit
		DG20AA40	DG20AA80	DG20AA120	DG20AA160	
V_{RRM}	Repetitive Peak Reverse Voltage	400	800	1200	1600	V
V_{RSM}	Non-Repetitive Peak Reverse Voltage	480	960	1300	1700	V

Symbol	Item	Conditions	Ratings	Unit
$I_{F(AV)}$	Average Forward Current	Single phase, half wave, 180° conduction, $T_c : 101^\circ C$	20	A
$I_{F(RMS)}$	R.M.S. Forward Current	Single phase, half wave, 180° conduction, $T_c : 101^\circ C$	31	A
I_{FSM}	Surge Forward Current	$1/2$ cycle, 50Hz/60Hz, peak value, non-repetitive	410/450	A
I^2t	I^2t	Value for one cycle of surge current	840	A^2S
T_j	Junction Temperature		-40 to +150	$^\circ C$
T_{stg}	Storage Temperature		-40 to +125	$^\circ C$
V_{ISO}	Isolation Breakdown Voltage (R.M.S.)	A.C. 1 minute	2500	$^\circ C$
	Mounting Torque (M4)	Recommended Value 1.0-1.4 (10-14)	1.5 (15)	$N \cdot m$ ($kgf \cdot cm$)
	Mass		23	g

Electrical Characteristics

Symbol	Item	Conditions	Ratings	Unit
I_{RRM}	Repetitive Peak Reverse Current, max.	at V_{DRM} , single phase, half wave, $T_j = 125^\circ C$	8	mA
V_{FM}	Forward Voltage Drop, max.	Forward current 65A, $T_j = 25^\circ C$, Inst. measurement	1.65	V
$R_{th(j-c)}$	Thermal Impedance, max.	Junction to case	1.60	$^\circ C/W$

