

**Monolithic CMOS Analog Switches**

The DG401, DG403 and DG405 monolithic CMOS analog switches have TTL and CMOS compatible digital inputs.

These switches feature low analog ON resistance (<45Ω) and fast switch time ( $t_{ON} < 150ns$ ). Low charge injection simplifies sample and hold applications.

The improvements in the DG401/403/405 series are made possible by using a high voltage silicon-gate process. An epitaxial layer prevents the latch-up associated with older CMOS technologies. The 44V maximum voltage range permits controlling 30V<sub>P-P</sub> signals. Power supplies may be single-ended from +5V to +34V, or split from ±5V to ±17V.

The analog switches are bilateral, equally matched for AC or bidirectional signals. The ON resistance variation with analog signals is quite low over a ±15V analog input range. The three different devices provide the equivalent of two SPST (DG401), two SPDT (DG403) or two DPST (DG405) relay switch contacts with CMOS or TTL level activation. The pinout is similar, permitting a standard layout to be used, choosing the switch function as needed.

**Pinouts**

**DG401 (PDIP, SOIC)  
TOP VIEW**

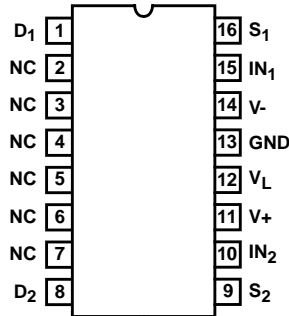

**DG403, DG405 (SOIC)  
TOP VIEW**

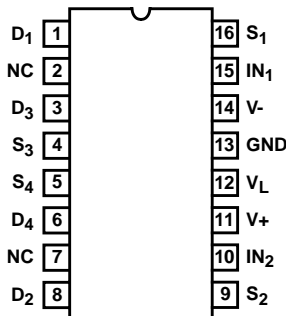

NOTE: (NC) No Connection.

**Features**

- ON Resistance (Max) . . . . . 45Ω
- Low Power Consumption (P<sub>D</sub>) . . . . . <35μW
- Fast Switching Action
  - t<sub>ON</sub> (Max) . . . . . 150ns
  - t<sub>OFF</sub> (Max) . . . . . 100ns
- Low Charge Injection
- DG401 Dual SPST; Same Pinout as HI-5041
- DG403 Dual SPDT; DG190, IH5043, IH5151, HI-5051
- DG405 Dual DPST; DG184, HI-5045, IH5145
- TTL, CMOS Compatible
- Single or Split Supply Operation

**Applications**

- Audio Switching
- Battery Operated Systems
- Data Acquisition
- Hi-Rel Systems
- Sample and Hold Circuits
- Communication Systems
- Automatic Test Equipment

**Ordering Information**

PART NUMBER	TEMP. RANGE (°C)	PACKAGE	PKG. NO.
DG401DJ	-40 to 85	16 Ld PDIP	E16.3
DG401DY	-40 to 85	16 Ld SOIC	M16.15
DG403DJ	-40 to 85	16 Ld PDIP	E16.3
DG403DY	-40 to 85	16 Ld SOIC	M16.15
DG405DY	-40 to 85	16 Ld SOIC	M16.15

**TRUTH TABLE**

LOGIC	DG401	DG403		DG405
	SWITCH	SWITCH 1, 2	SWITCH 3, 4	SWITCH
0	OFF	OFF	ON	OFF
1	ON	ON	OFF	ON

NOTE: Logic "0" ≤0.8V. Logic "1" ≥2.4V.

**Functional Diagrams**

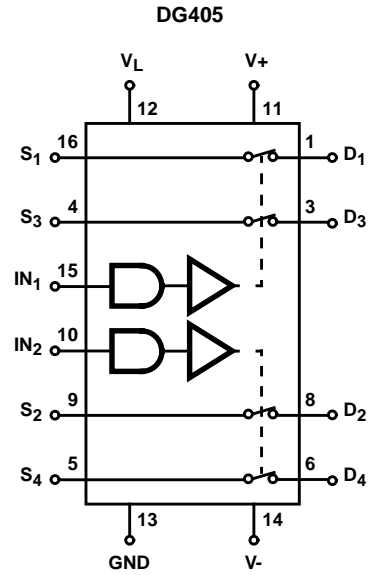
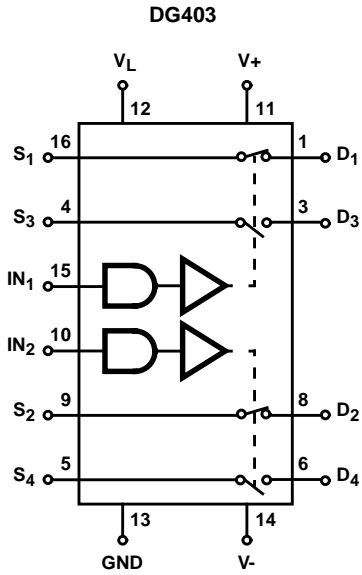
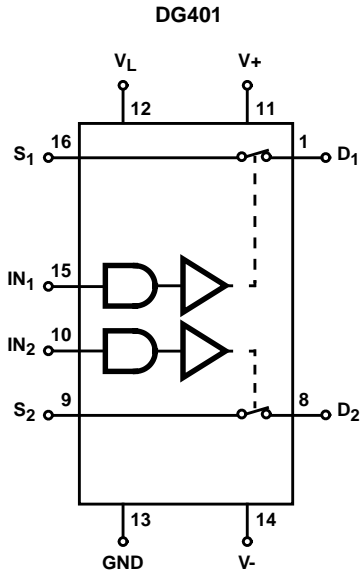

SWITCHES SHOWN FOR LOGIC "1" INPUT

**Schematic Diagram**

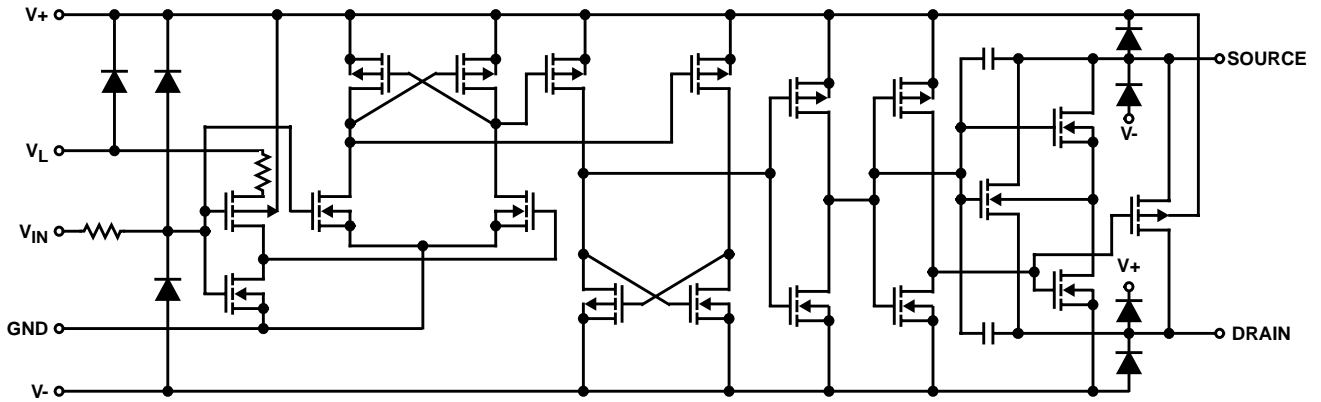

# DG401, DG403, DG405

## Absolute Maximum Ratings

V+ to V-	44.0V
GND to V-	25V
V <sub>L</sub>	(GND - 0.3V) to (V+) +0.3V
Digital Inputs V <sub>S</sub> , V <sub>D</sub> (Note 1)	(V-) -2V to (V+) + 2V or 30mA, Whichever Occurs First
Continuous Current (Any Terminal)	30mA
Peak Current, S or D (Pulsed 1ms, 10% Duty Cycle, Max)	100mA

## Thermal Information

Thermal Resistance (Typical, Note 2)	$\theta_{JA}$ (°C/W)
PDIP Package	90
SOIC Package	115
Maximum Junction Temperature (Plastic Package)	150°C
Maximum Storage Temperature Range	-65°C to 150°C
Maximum Lead Temperature (Soldering 10s)	300°C (SOIC - Lead Tips Only)

## Operating Conditions

Temperature Range	-40°C to 85°C
Voltage Range	±20V (Max)
Input Low Voltage	0.8V (Max)
Input High Voltage	2.4V (Min)
Input Rise and Fall Time	≤20ns

**CAUTION:** Stresses above those listed in "Absolute Maximum Ratings" may cause permanent damage to the device. This is a stress only rating and operation of the device at these or any other conditions above those indicated in the operational sections of this specification is not implied.

### NOTES:

1. Signals on S<sub>X</sub>, D<sub>X</sub>, or IN<sub>X</sub> exceeding V+ or V- will be clamped by internal diodes. Limit forward diode current to maximum current ratings.
2.  $\theta_{JA}$  is measured with the component mounted on an evaluation PC board in free air.

## Electrical Specifications

Test Conditions: V+ = +15V, V- = -15V, V<sub>IN</sub> = 2.4V, 0.8V (Note 3), V<sub>L</sub> = 5V,  
Unless Otherwise Specified

PARAMETER	TEST CONDITIONS	TEMP (°C)	(NOTE 4) MIN	(NOTE 5) TYP	(NOTE 4) MAX	UNITS
<b>DYNAMIC CHARACTERISTICS</b>						
Turn-ON Time, t <sub>ON</sub>	R <sub>L</sub> = 300Ω, C <sub>L</sub> = 35pF	25	-	100	150	ns
Turn-OFF Time, t <sub>OFF</sub>		25	-	60	100	ns
Break-Before-Make Time Delay (DG403), t <sub>D</sub>	R <sub>L</sub> = 300Ω, C <sub>L</sub> = 35pF	25	5	12	-	ns
Charge Injection, Q (Figure 3)	C <sub>L</sub> = 10nF, V <sub>G</sub> = 0V, R <sub>G</sub> = 0Ω	25	-	60	-	pC
OFF Isolation (Figure 4)	R <sub>L</sub> = 100Ω, C <sub>L</sub> = 5pF, f = 1MHz	25	-	72	-	dB
Crosstalk (Channel-to-Channel) (Figure 6)		25	-	-90	-	dB
Source OFF Capacitance, C <sub>S(OFF)</sub>	f = 1MHz, V <sub>S</sub> = V <sub>D</sub> = 0V (Figure 7)	25	-	12	-	pF
Drain OFF Capacitance, C <sub>D(OFF)</sub>		25	-	12	-	pF
Channel ON Capacitance, C <sub>D(ON)</sub> + C <sub>S(ON)</sub>		25	-	39	-	pF
<b>DIGITAL INPUT CHARACTERISTICS</b>						
Input Current with V <sub>IN</sub> Low, I <sub>IL</sub>	V <sub>IN</sub> Under Test = 0.8V, All Others = 2.4V	Full	-1	0.005	1	μA
Input Current with V <sub>IN</sub> High, I <sub>IH</sub>	V <sub>IN</sub> Under Test = 2.4V, All Others = 0.8V	Full	-1	0.005	1	μA
<b>ANALOG SWITCH CHARACTERISTICS</b>						
Analog Signal Range, V <sub>ANALOG</sub>		Full	-15	-	15	V
Drain-Source ON Resistance, r <sub>DS(ON)</sub>	V+ = 13.5V, V- = -13.5V, I <sub>S</sub> = ±10mA, V <sub>D</sub> = ±10V	25	-	20	45	Ω
		Full	-	-	55	Ω
r <sub>DS(ON)</sub> Matching Between Channels, Δr <sub>DS(ON)</sub>	V+ = 16.5V, V- = -16.5V, I <sub>S</sub> = -10mA, V <sub>D</sub> = 5, 0, -5V	25	-	3	3	Ω
		Full	-	-	5	Ω
Source OFF Leakage Current, I <sub>S(OFF)</sub>	V+ = 16.5V, V- = -16.5 V <sub>D</sub> = ±15.5V, V <sub>S</sub> = ±15.5V	25	-0.5	-0.01	0.5	nA
		Full	-5	-	5	nA
Drain OFF Leakage Current, I <sub>D(OFF)</sub>		25	-0.5	-0.01	0.5	nA
		Full	-5	-	5	nA
Channel ON Leakage Current, I <sub>D(ON)</sub> + I <sub>S(ON)</sub>	V± = ±16.5V, V <sub>D</sub> = V <sub>S</sub> = ±15.5V	25	-1	-0.04	1	nA
		Full	-10	-	10	nA

**Electrical Specifications** Test Conditions:  $V_+ = +15V$ ,  $V_- = -15V$ ,  $V_{IN} = 2.4V, 0.8V$  (Note 3),  $V_L = 5V$ , Unless Otherwise Specified **(Continued)**

PARAMETER	TEST CONDITIONS	TEMP (°C)	(NOTE 4) MIN	(NOTE 5) TYP	(NOTE 4) MAX	UNITS
<b>POWER SUPPLY CHARACTERISTICS</b>						
Positive Supply Current, $I_+$	$V_+ = 16.5V$ , $V_- = -16.5V$ , $V_{IN} = 0V$ or $5V$	25	-	0.01	1	$\mu A$
		Full	-	-	5	$\mu A$
Negative Supply Current, $I_-$		25	-1	-0.01	-	$\mu A$
		Full	-5	-	-	$\mu A$
Logic Supply Current, $I_L$		25	-	0.01	1	$\mu A$
		Full	-	-	5	$\mu A$
Ground Current, $I_{GND}$		25	-1	-0.01	-	$\mu A$
		Full	-5	-	-	$\mu A$

NOTES:

- $V_{IN}$  = input voltage to perform proper function.
- The algebraic convention whereby the most negative value is a minimum and the most positive a maximum, is used in this data sheet.
- Typical values are for DESIGN AID ONLY, not guaranteed nor subject to production testing.

**Test Circuits and Waveforms**

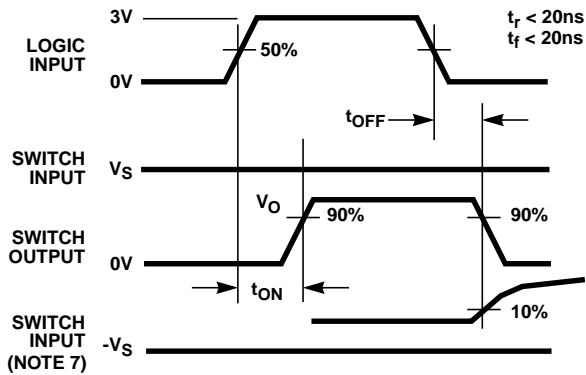

NOTES:

- Logic input waveform is inverted for switches that have the opposite logic sense.
- $V_S = 10V$  for  $t_{ON}$ ,  $V_S = -10V$  for  $t_{OFF}$ .

FIGURE 1A. MEASUREMENT POINTS

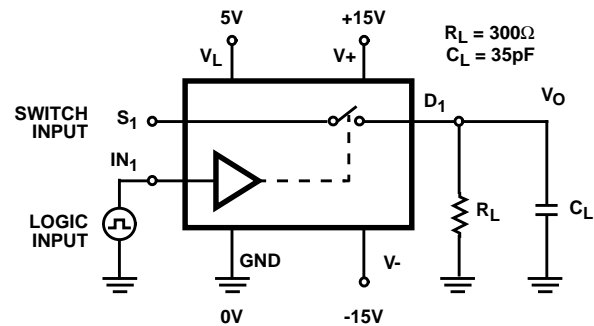

Repeat test for IN<sub>2</sub> and S<sub>2</sub>.

For load conditions, see Specifications.  $C_L$  includes fixture and stray capacitance.

$$V_O = V_S \frac{R_L}{R_L + r_{DS(ON)}}$$

FIGURE 1B. TEST CIRCUIT

FIGURE 1. SWITCHING TIMES

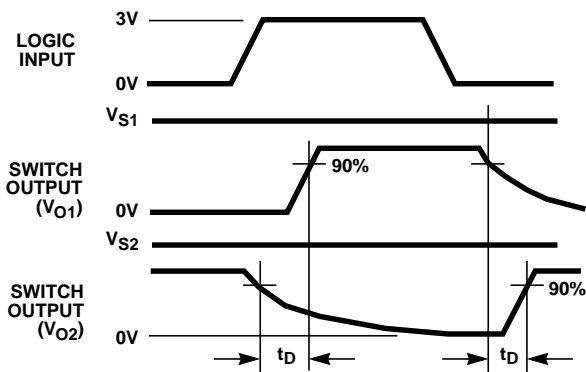
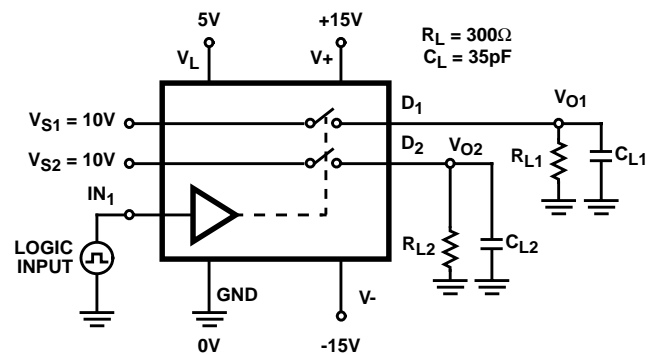

FIGURE 2A. MEASUREMENT POINTS



$C_L$  includes fixture and stray capacitance.

FIGURE 2B. TEST CIRCUIT

FIGURE 2. BREAK-BEFORE-MAKE TIME

Test Circuits and Waveforms (Continued)

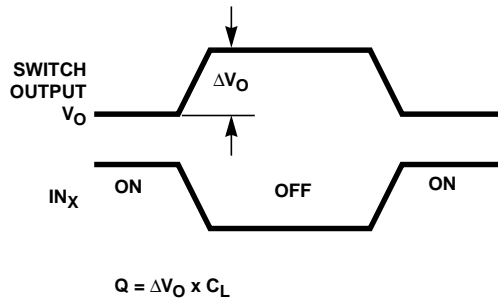

FIGURE 3A. MEASUREMENT POINTS

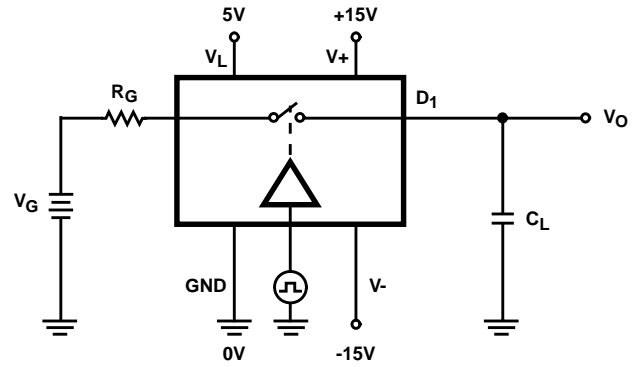

FIGURE 3B. TEST CIRCUIT

FIGURE 3. CHARGE INJECTION

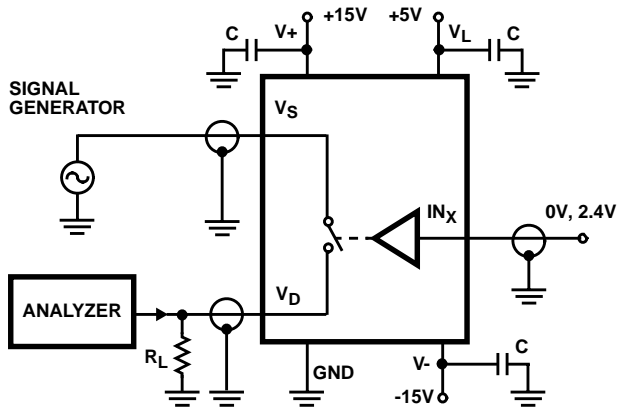

FIGURE 4. OFF ISOLATION TEST CIRCUIT

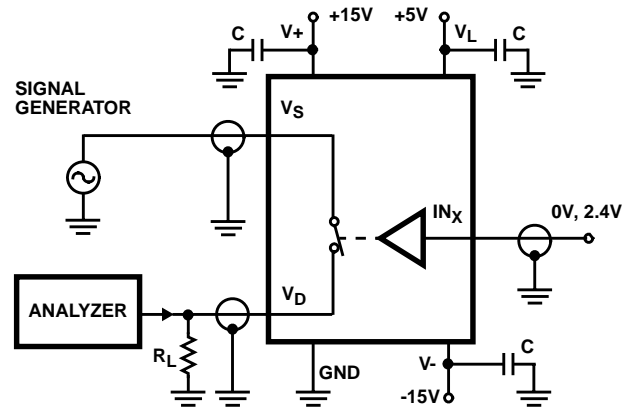

FIGURE 5. INSERTION LOSS TEST CIRCUIT

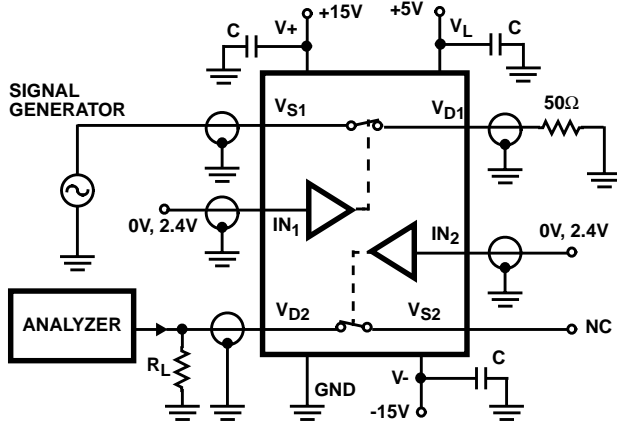

FIGURE 6. CROSSTALK TEST CIRCUIT

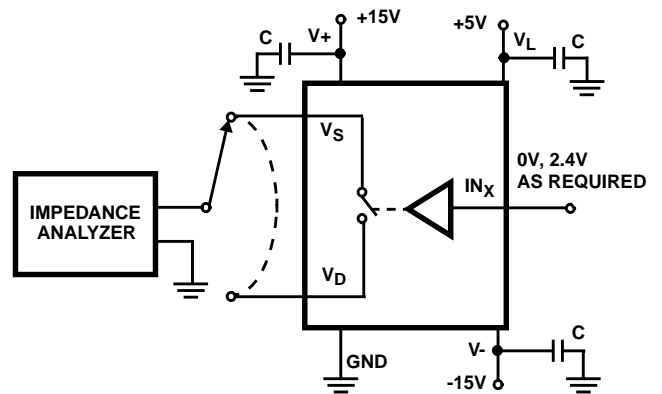

FIGURE 7. CAPACITANCES TEST CIRCUIT

## Application Information

### Dual Slope Integrators

The DG403 is well suited to configure a selectable slope integrator. One control signal selects the timing capacitor  $C_1$  or  $C_2$ . Another one selects  $e_{IN}$  or discharges the capacitor in preparation for the next integration cycle.

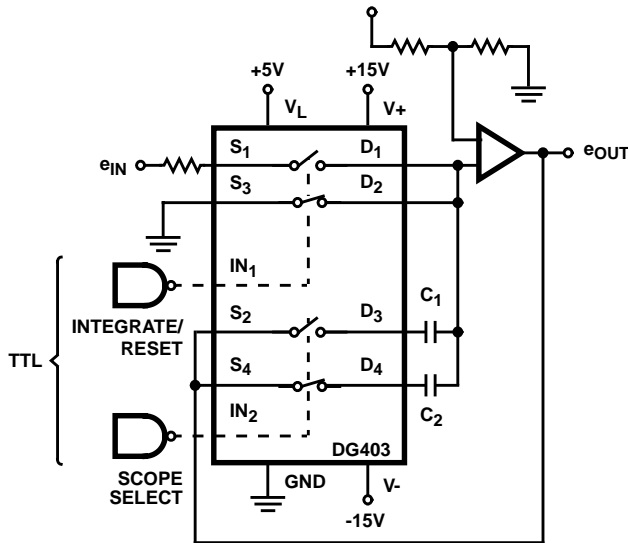

FIGURE 8. DUAL SLOPE INTEGRATOR

### Peak Detector

$A_3$  acting as a comparator provides the logic drive for operating  $SW_1$ . The output of  $A_2$  is fed back to  $A_3$  and compared to the analog input  $e_{IN}$ . If  $e_{IN} > e_{OUT}$  the output of  $A_3$  is high keeping  $SW_1$  closed. This allows  $C_1$  to charge up to the analog input voltage. When  $e_{IN}$  goes below  $e_{OUT}$ ,  $A_3$  goes negative, turning  $SW_1$  off. The system will therefore store the most positive analog input experienced.

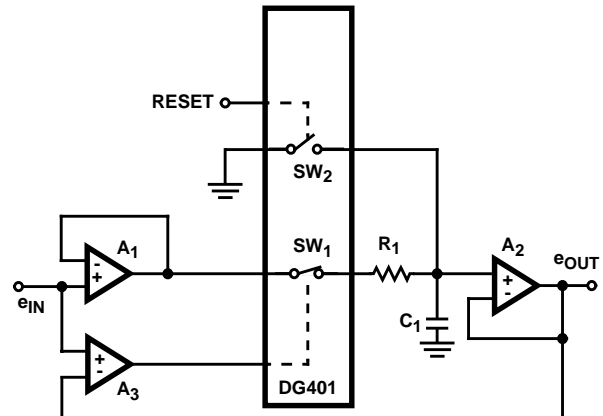

FIGURE 9. POSITIVE PEAK DETECTOR

## Typical Performance Curves

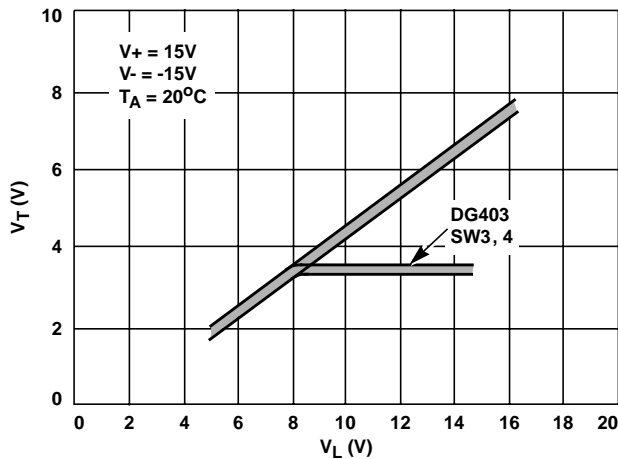

FIGURE 10. INPUT SWITCHING THRESHOLD vs LOGIC SUPPLY VOLTAGE

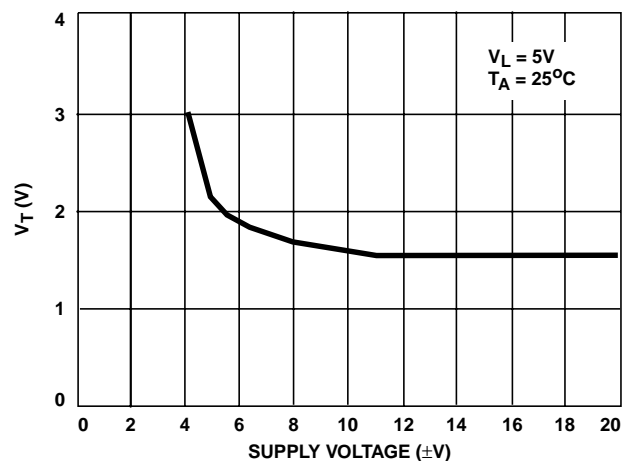

FIGURE 11. INPUT SWITCHING THRESHOLD vs POWER SUPPLY VOLTAGE

All Intersil semiconductor products are manufactured, assembled and tested under **ISO9000** quality systems certification.

*Intersil semiconductor products are sold by description only. Intersil Corporation reserves the right to make changes in circuit design and/or specifications at any time without notice. Accordingly, the reader is cautioned to verify that data sheets are current before placing orders. Information furnished by Intersil is believed to be accurate and reliable. However, no responsibility is assumed by Intersil or its subsidiaries for its use; nor for any infringements of patents or other rights of third parties which may result from its use. No license is granted by implication or otherwise under any patent or patent rights of Intersil or its subsidiaries.*

For information regarding Intersil Corporation and its products, see web site <http://www.intersil.com>

Typical Performance Curves (Continued)

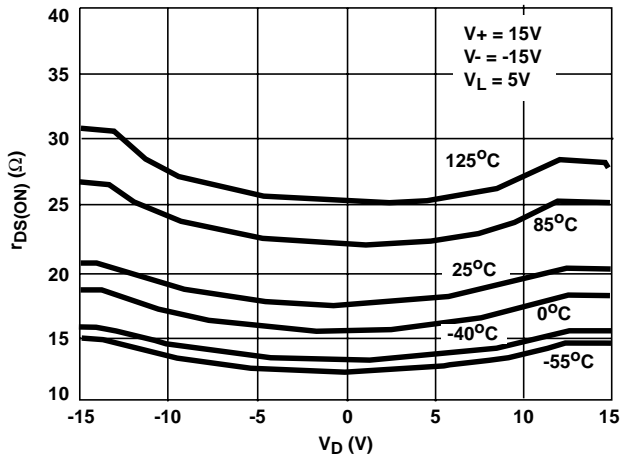

FIGURE 12.  $r_{DS(ON)}$  vs  $V_D$  AND TEMPERATURE

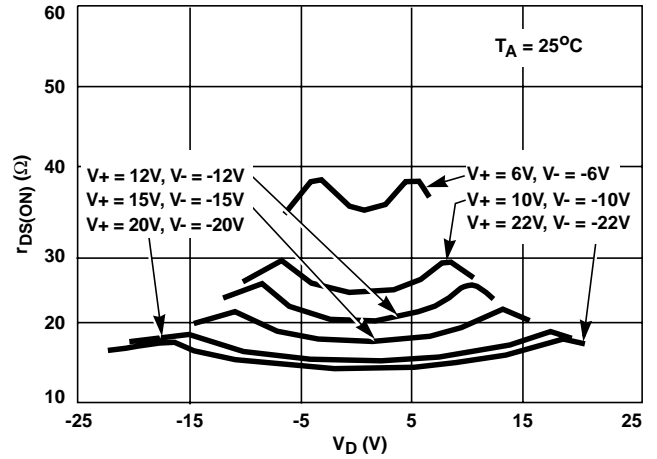

FIGURE 13.  $r_{DS(ON)}$  vs  $V_D$  AND POWER SUPPLY VOLTAGE

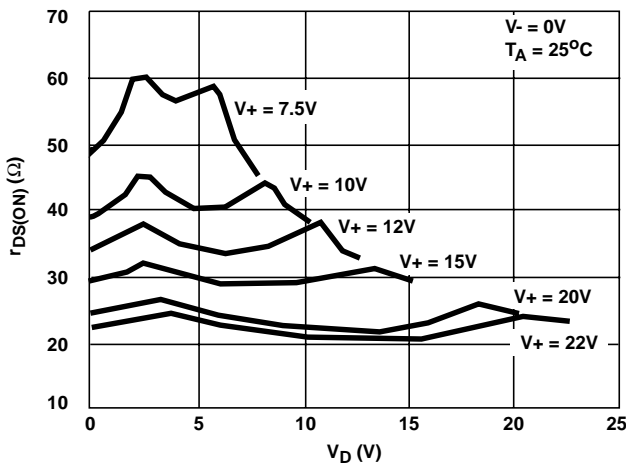

FIGURE 14.  $r_{DS(ON)}$  vs  $V_D$  AND SINGLE SUPPLY VOLTAGE

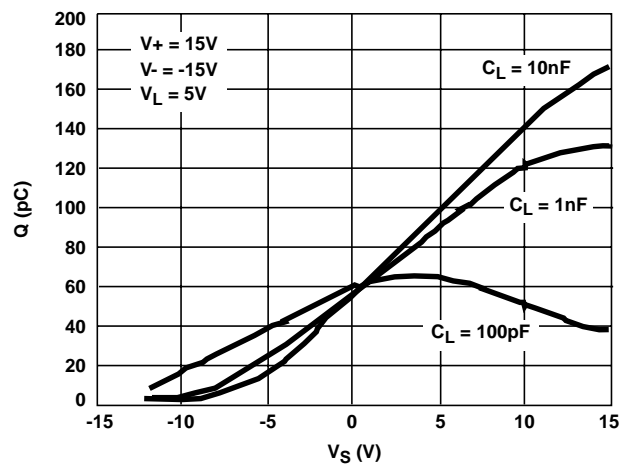

FIGURE 15. CHARGE INJECTION vs SOURCE VOLTAGE

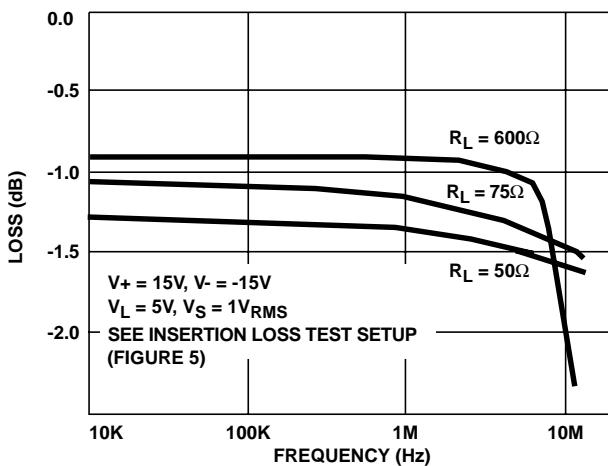

FIGURE 16. INSERTION LOSS vs FREQUENCY

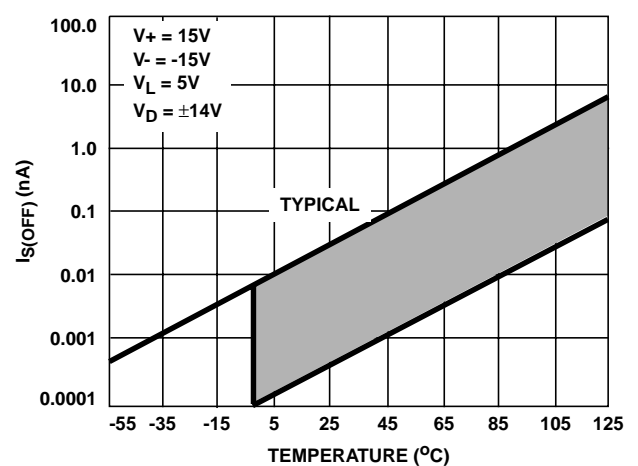

FIGURE 17.  $I_{S(OFF)}$  vs TEMPERATURE

Typical Performance Curves (Continued)

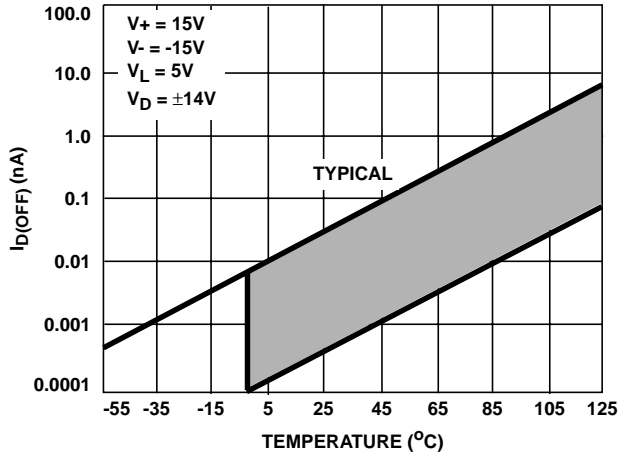

FIGURE 18.  $I_{D(OFF)}$  vs TEMPERATURE

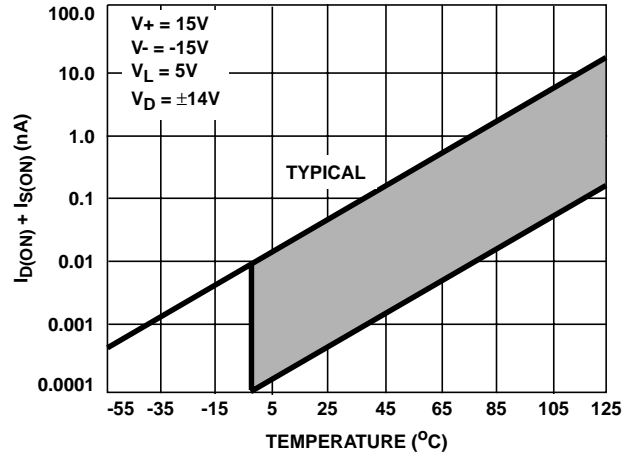

FIGURE 19.  $I_{D(ON)} + I_{S(ON)}$  vs TEMPERATURE

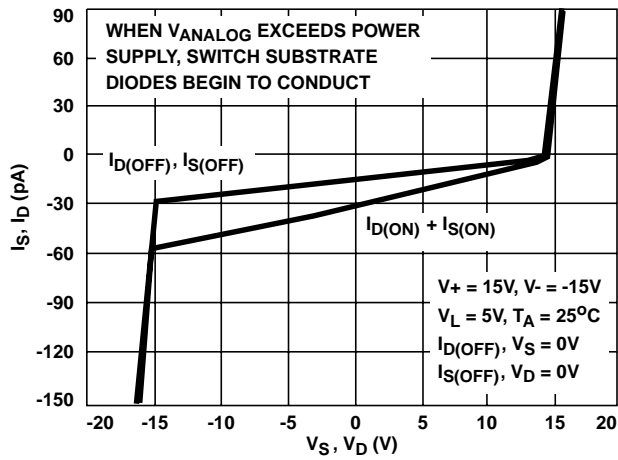

FIGURE 20. LEAKAGE CURRENTS vs ANALOG VOLTAGE

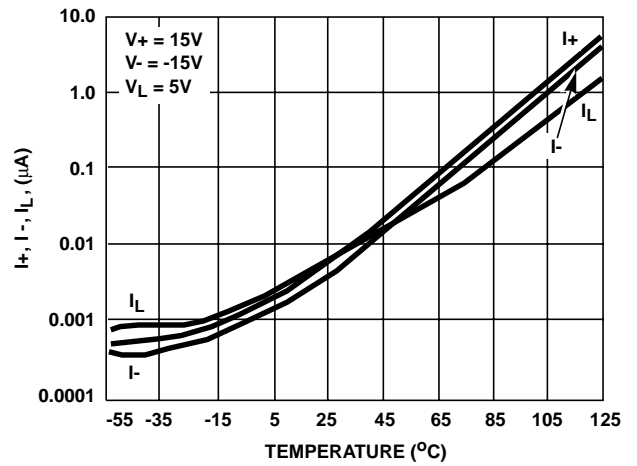

FIGURE 21. SUPPLY CURRENT vs TEMPERATURE

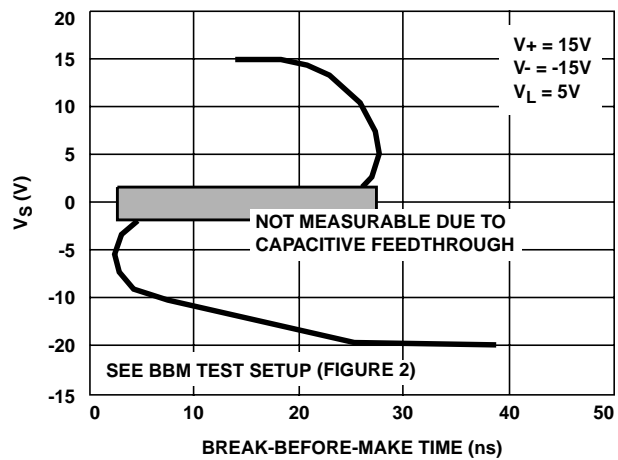

FIGURE 22. BREAK-BEFORE-MAKE vs ANALOG VOLTAGE

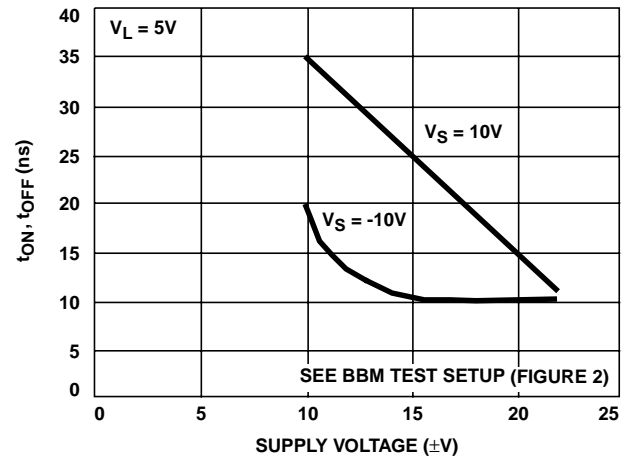

FIGURE 23. BREAK-BEFORE-MAKE vs POWER SUPPLY VOLTAGE

Typical Performance Curves (Continued)

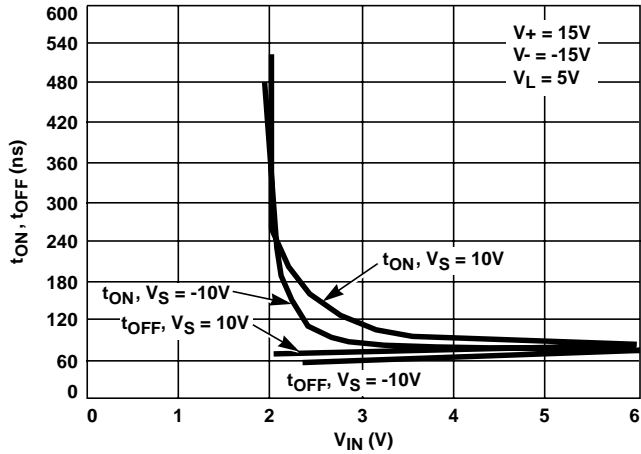

FIGURE 24. SWITCHING TIME vs INPUT LOGIC VOLTAGE (NOTE 8)

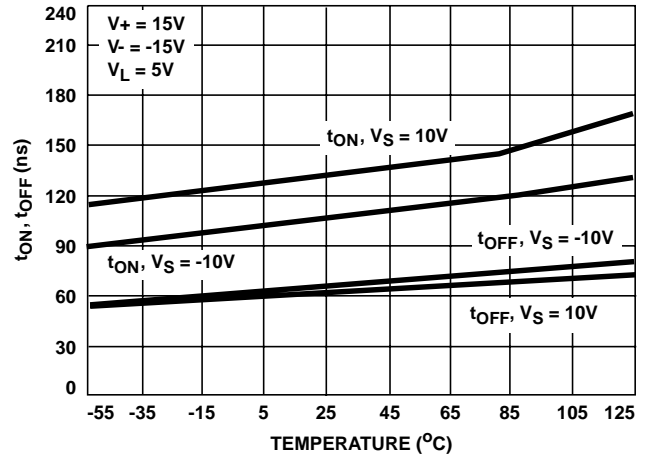

FIGURE 25. SWITCHING TIME vs TEMPERATURE (NOTE 8)

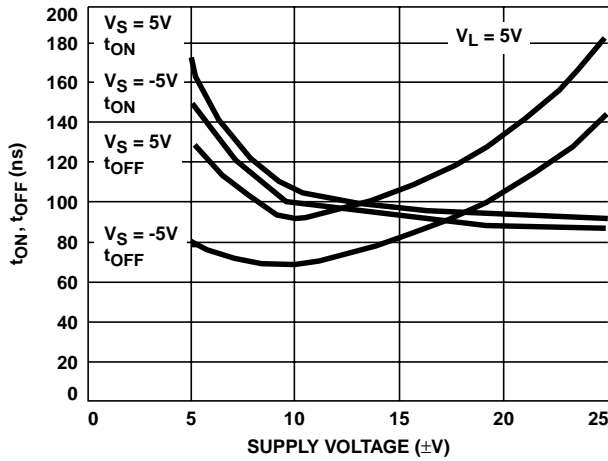

FIGURE 26. SWITCHING TIME vs POWER SUPPLY VOLTAGE (NOTE 8)

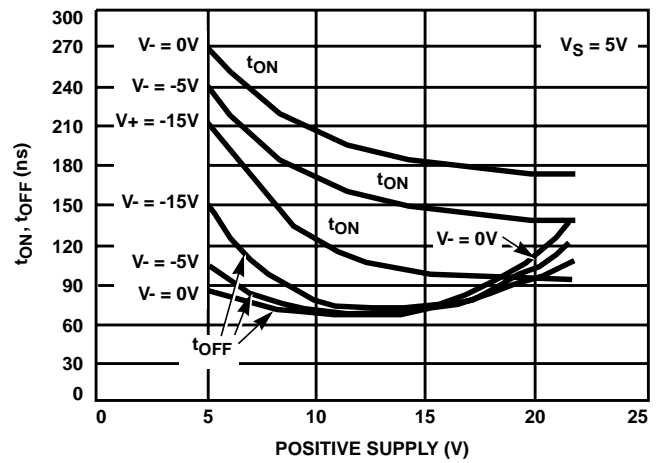

FIGURE 27. SWITCHING TIME vs POSITIVE SUPPLY VOLTAGE (NOTE 8)

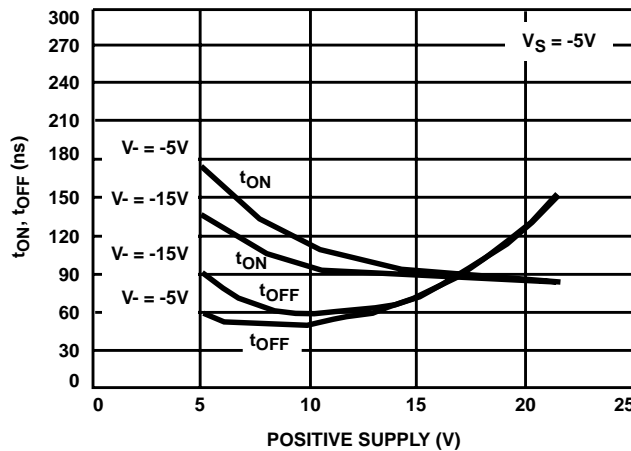

FIGURE 28. SWITCHING TIME vs POSITIVE SUPPLY VOLTAGE (NOTE 8)

NOTE:

8. Refer to Figure 1 for test conditions.

This datasheet has been downloaded from:

[www.DatasheetCatalog.com](http://www.DatasheetCatalog.com)

Datasheets for electronic components.



LittleDiode supplies new, hard to find or obsolete electronic components and semiconductors all over the world.

With over two million different components listed you are sure to find the part you need.

Feel free to visit us today at our online store:

[LittleDiode.com](http://LittleDiode.com)

Looking forward to providing you with the best possible service.