



Monolithic CMOS Analog Multiplexers

DG508A/DG509A

General Description

Maxim's DG508A and DG509A are monolithic CMOS analog multiplexers (muxes): the DG508A is a single 8-channel (1-of-8) mux, and the DG509A is a differential 4-channel (2-of-8) mux.

Both devices guarantee break-before-make switching. Maxim guarantees these muxes will not latch up if the power supplies are turned off with the input signals still present. Maxim also guarantees continuous operation when these devices are powered by supplies ranging from $\pm 4.5V$ to $\pm 18V$.

The DG508A/DG509A are plug-in upgrades for the industry-standard DG08A/DG509A, respectively. Maxim's parts have lower on-resistance, faster enable switching times, and significantly lower leakage currents. The DG508A/DG509A also consume significantly lower power, making them ideal for portable equipment.

Applications

- Control Systems
- Data Logging Systems
- Aircraft Heads-Up Displays
- Data-Acquisition Systems
- Signal Routing

Typical Operating Circuits

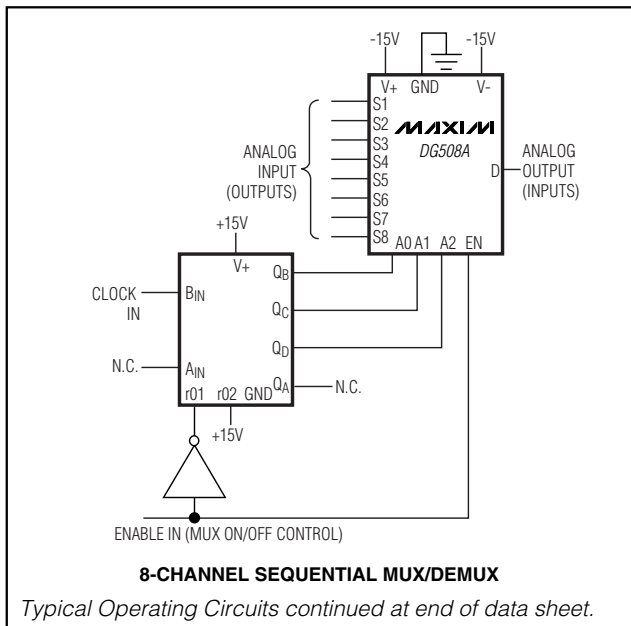

Features

- ◆ Improved Second Source
- ◆ Operate from $\pm 4.5V$ to $\pm 18V$ Supplies
- ◆ Symmetrical, Bidirectional Operation
- ◆ Logic and Enable Inputs, TTL and CMOS Compatible
- ◆ Latchup-Proof Construction
- ◆ Monolithic, Low-Power CMOS Design

Ordering Information

PART	TEMP RANGE	PIN-PACKAGE
DG508ACJ	0°C to +70°C	16 Plastic DIP
DG508ACWE	0°C to +70°C	16 Wide SO
DG508AC/D	0°C to +70°C	Dice*
DG508ABK	-20°C to +85°C	16 CERDIP
DG508ADJ	-40°C to +85°C	16 Plastic DIP
DG508ADY	-40°C to +85°C	16 Narrow SO
DG508AEGE	-40°C to +85°C	16 QFN
DG508AEWE	-40°C to +85°C	16 Wide SO
DG508AAK	-55°C to +125°C	16 CERDIP

Ordering Information continued at end of data sheet.

*Contact factory for dice specifications.

Pin Configurations

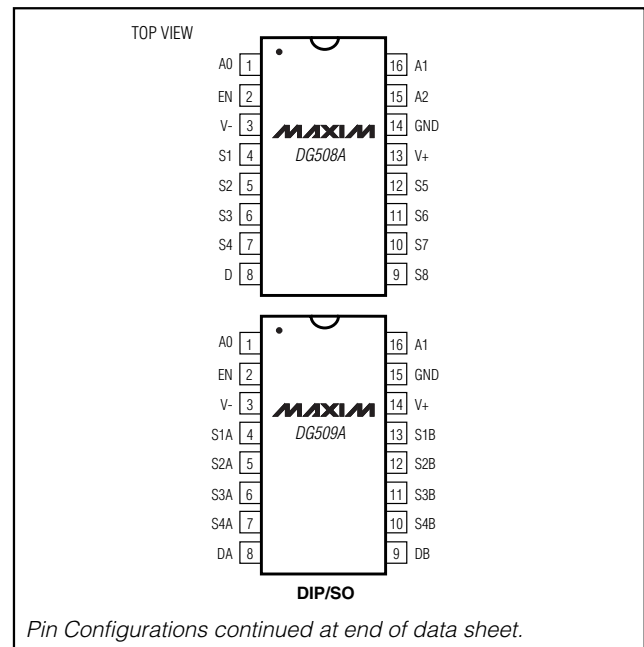

Monolithic CMOS Analog Multiplexers

ABSOLUTE MAXIMUM RATINGS

Voltage Referenced to V-

V+	+44V
GND	+25V
Digital Inputs, V _S and V _D (Note 1)	-2V to (V+ + 2V) or 20mA, whichever occurs first

Current (any terminal, except S or D)	30mA
Continuous Current, S or D	20mA
Peak Current, S or D (pulsed at 1ms, 10% duty cycle max)	40mA
Continuous Power Dissipation (T _A = +70°C)	
Plastic DIP (derate 10.53mW/°C above +70°C)	842mW
QFN (derate 19.2mW/°C above +70°C)	1538mW
Narrow SO (derate 8.70mW/°C above +70°C)	696mW
Wide SO (derate 9.52mW/°C above +70°C)	762mW
CERDIP (derate 10.00mW/°C above +70°C)	800mW

Operating Temperature Ranges:

DG50_ACJ/CWE/CGE	0°C to +70°C
DG50_ABK	-20°C to +85°C
DGS0_ADJ/DY/EWE/EGE	-40°C to +85°C
DG50_AAK	-55°C to +125°C
Storage Temperature Range	-65°C to +150°C
Lead Temperature (soldering, 10s)	+300°C

Note 1: Signals on S₋, D₋, or IN₋ exceeding V+ or V- are clamped by internal diodes. Limit forward-diode current to maximum current ratings

Stresses beyond those listed under "Absolute Maximum Ratings" may cause permanent damage to the device. These are stress ratings only, and functional operation of the device at these or any other conditions beyond those indicated in the operational sections of the specifications is not implied. Exposure to absolute maximum rating conditions for extended periods may affect device reliability.

ELECTRICAL CHARACTERISTICS

(V+ = 15V, V- = -15V, GND = 0V, T_A = +25°C, unless otherwise noted.)

PARAMETER	SYMBOL	CONDITIONS	DG508AA DG509AA			DG508AD/E/B/C DG509AD/E/B/C			UNITS
			MIN	TYP	MAX	MIN	TYP	MAX	
SWITCH									
Analogue Signal Range	V _{ANALOG}		-15		+15	-15		+15	V
Drain-Source On-Resistance	R _{DS(ON)}	Sequence each switch on, V _{AL} = 0.8V, V _{AH} = 2.4V (Note 4)	V _D = 10V, I _S = -200μA	170	300	170	350		Ω
			V _D = 10V, I _S = -200μA	130	300	130	350		
Greatest Change in Drain-Source On-Resistance Between Channels	ΔR _{DS(ON)}	$\Delta R_{DS(ON)} = \left(\frac{R_{DS(ON) \max} - R_{DS(ON) \min}}{R_{DS(ON)}} \right)$ -10V ≥ V _S ≥ 10V		6			6		%
Source Off-Leakage Current	I _{S(OFF)}	V _{EN} = 0V	V _S = 10V, V _D = -10V	0.002	0.5	0.002	1		nA
			V _S = -10V, V _D = 10V	-0.5	-0.005	-1	-0.005		
Drain Off-Leakage Current	DG508A DG509A	I _{D(OFF)}	V _{EN} = 0V	V _D = 10V, V _S = -10V	0.01	2	0.01	5	nA
				V _D = 10V, V _S = -10V	-2	-0.015	-5	-0.015	
				V _D = 10V, V _S = -10V	0.005	2	0.005	5	
				V _D = -10V, V _S = 10V	-2	-0.008	-5	-0.008	
Drain On-Leakage Current	DG508A DG509A	I _{D(ON)}	Sequence each switch on, V _{AL} = 0.8V V _{AH} = 2.4V (Note 2)	V _{S(all)} = V _D = 10V	0.015	2	0.015	5	nA
				V _{S(all)} = V _D = -10V	-2	-0.03	-5	-0.03	
				V _{S(all)} = V _D = 10V	0.007	2	0.007	5	
				V _{S(all)} = V _D = -10V	-2	-0.015	-5	-0.015	

Monolithic CMOS Analog Multiplexers

DG508A/DG509A

ELECTRICAL CHARACTERISTICS (continued)

(V+ = 15V, V- = -15V, GND = 0V, TA = +25°C, unless otherwise noted.)

PARAMETER	SYMBOL	CONDITIONS	DG508AA DG509AA			DG508AD/E/B/C DG509AD/E/B/C			UNITS
			MIN	TYP	MAX	MIN	TYP	MAX	
LOGIC INPUT									
Logic Input Current, Input Voltage High	IAH	VA = 24V	-10	-0.002		10	-0.002		μA
		VA = 15V		0.006	10		0.006	10	
Logic Input Current, Input Voltage Low	IAL	All VA = 0V	VEN = 2.4V	-10	-0.002		10	-0.002	μA
			VEN = 0V	-10	-0.002		-10	-0.002	
DYNAMIC									
Multiplexer Switching Time	ttransition	Figure 1		0.6	1.0		0.6	1.0	μs
Break-Before-Make Interval	tOPEN	Figure 3		0.2			0.2		μs
Enable Turn-On Time	tON(EN)	Figure 2		0.4	1.0		0.4	1.5	μs
Enable Turn-Off Time	tOFF(EN)	Figure 2		0.2	0.7		0.2	1.0	μs
Off-Isolation	OIRR	VEN = 0V, RL = 1kΩ, CL = 15pF, VS = 7VRMS f = 500kHz (Note 3)		68			68		dB
Source Off-Capacitance	CS(OFF)	VS = 0V, VEN = 0V, f = 140kHz		5			5		pF
Drain Off-Capacitance	IDG508A	VS = 0V, VEN = 0V, f = 140kHz		25			25		pF
	DGS09A			12			12		
SUPPLY									
Positive Supply Current	I+	VEN = 2.4V, all VA = 0V or 2.4V		0.02	0.2		0.02	0.2	mA
Negative Supply Current	I-	VEN = 2.4V, all VA = 0V or 2.4V	-0.1	-0.01		-0.1	-0.01		mA
Positive Supply Current in Standby	I+	VEN = 0V, all VA = 0V or 2.4V		0.02	0.2		0.02	0.2	mA
Negative Supply Current in Standby	I-	VEN = 0V, all VA = 0V or 2.4V	-0.1	-0.01		-0.1	-0.01		mA
Power-Supply Range for Continuous Operation	V-, V+	(Notes 4, 5)	±4.5		±18.0	±4.5		±18.0	V

Monolithic CMOS Analog Multiplexers

DG508A/DG509A

ELECTRICAL CHARACTERISTICS

(V+ = 15V, GND = 0V, T_A = T_{MIN} to T_{MAX}, unless otherwise noted.)

PARAMETER	SYMBOL	CONDITIONS	DG508AA DG509AA			DG508AD/E/B/C DG509AD/E/B/C			UNITS
			MIN	TYP	MAX	MIN	TYP	MAX	
SWITCH									
Analog Signal Range	V _{ANALOG}		-15		+15	-15		+15	V
Drain-Source On-Resistance	R _{DS(ON)}	Sequence each switch on, V _{AL} = 0.8V, V _{AH} = 2.4V	V _D = 10V, I _S = -200μA		400			450	Ω
			V _D = 10V, I _S = -200μA		400			450	
Source Off-Leakage Current	I _{S(OFF)}	V _{EN} = 0V	V _S = 10V, V _D = -10V		+50			+50	nA
			V _S = -10V, V _D = -10V	-50		-50			
Drain Off-Leakage Current	DG508A	V _{EN} = 0V	V _D = 10V, V _S = -10V		+200			+100	nA
			V _D = -10V, V _S = -10V	-200		-200			
	DG509A		V _D = 10V, V _S = -10V		+200			+100	
	DG509A		V _D = -10V, V _S = -10V	-100		-100			
Drain On-Leakage Current	DG508A	Sequence each switch on, V _{AL} = 0.8V, V _{AH} = 2.4V (Note 2)	V _{S(all)} = V _D = 10V		+200			+100	nA
			V _{S(all)} = V _D = -10V	-200		-100			
	DG509A		V _{S(all)} = V _D = 10V		+100			+100	
	DG509A		V _{S(all)} = V _D = -10V	-100		-100			
LOGIC INPUT									
Logic Input Current, Input Voltage High	I _{AH}	V _A = 2.4V	-30			-30			μA
		V _A = 15V			+30		+30		
Logic Input Current, Input Voltage Low	I _{AL}	All V _A = 0V	V _{EN} = 2.4V	-30		-30			μA
			V _{EN} = 0V	-30		-30			

Note 2: I_{D(ON)} is leakage from driver into on switch.

Note 3: Off-isolation = 20log $\frac{|V_S|}{|V_D|}$

V_S = input to off switch,
V_D = output due to V_S.

Note 4: Electrical characteristics (such as on-resistance) change when power supplies other than ±15V are used.

Note 5: For designs requiring single 5V or dual ±5V operation, refer to Maxim's improved MAX338 and MAX339. Minimum operating voltage for DG508ADY and DG509ADY is ±9V.

Monolithic CMOS Analog Multiplexers

Pin Description

DG508A/DG509A

PIN				NAME	FUNCTION
DG508A		DG509A			
DIP/SO	QFN	DIP/SO	QFN		
1, 15, 16	15, 14, 13	—	—	A0, A2, A1	Address Input
—	—	1, 16	15, 14	A0, A1	Address Input
2	16	2	16	EN	Enable
3	1	3	1	V-	Negative-Supply Voltage Input
4-7	2-5	—	—	S1-S4	Analog Inputs, Bidirectional
—	—	4-7	2-5	S1A-S4A	Analog Inputs, Bidirectional
8	6	—	—	D	Analog Outputs, Bidirectional
—	—	8, 9	6, 7	DA, DB	Analog Outputs, Bidirectional
9-12	7-10	—	—	S8-S5	Analog Inputs, Bidirectional
—	—	10-13	8-11	S4B-S1B	Analog Inputs, Bidirectional
13	11	14	12	V+	Positive-Supply Voltage Input
14	12	15	13	GND	Ground

Functional Diagrams

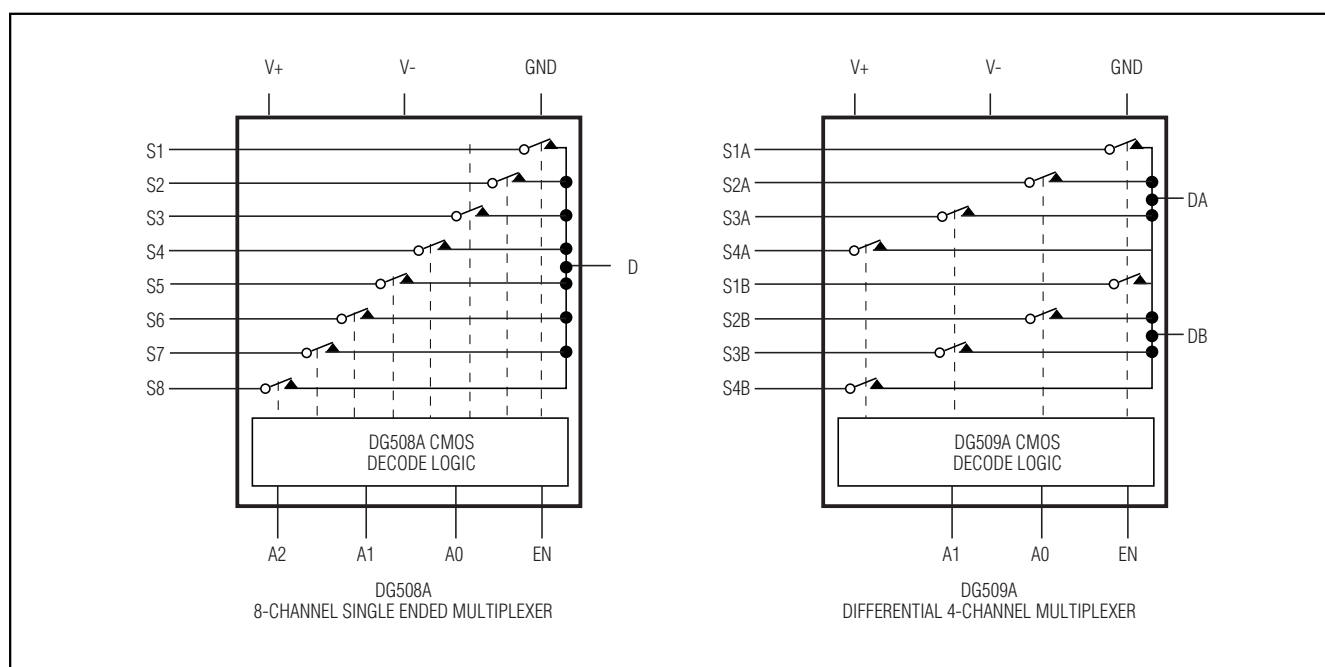

Monolithic CMOS Analog Multiplexers

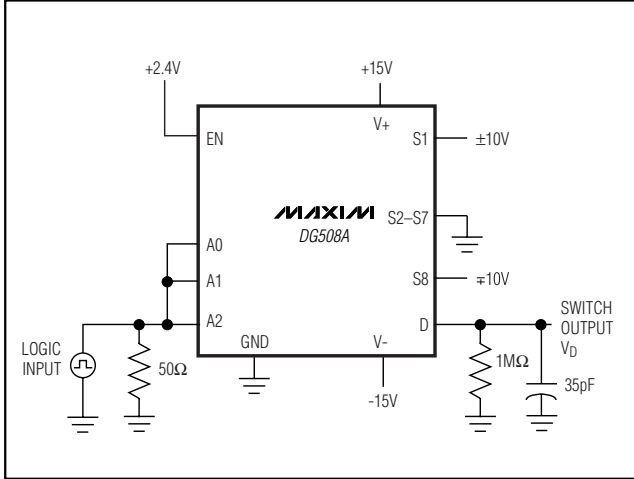

Figure 1a. Switching-Time Test Circuit

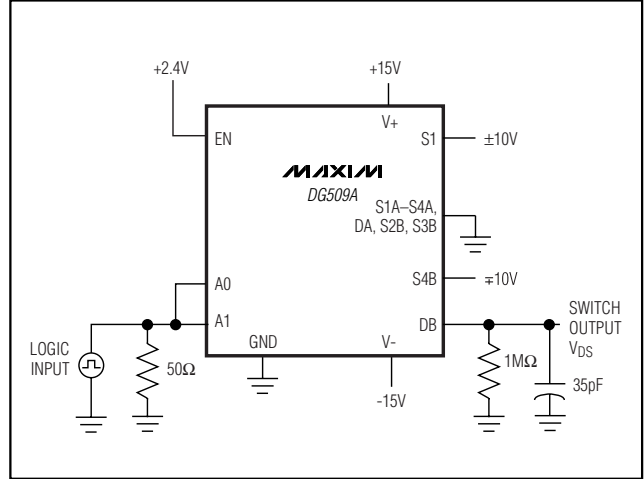

Figure 1b. Switching-Time Test Circuit

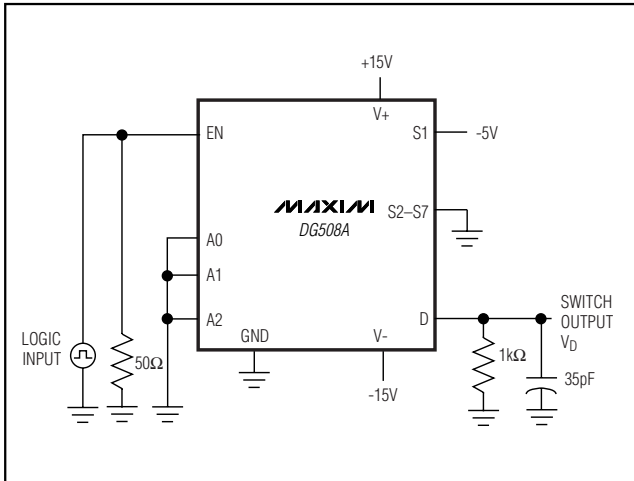

Figure 2a. DG508A Enable-Time Test Circuit

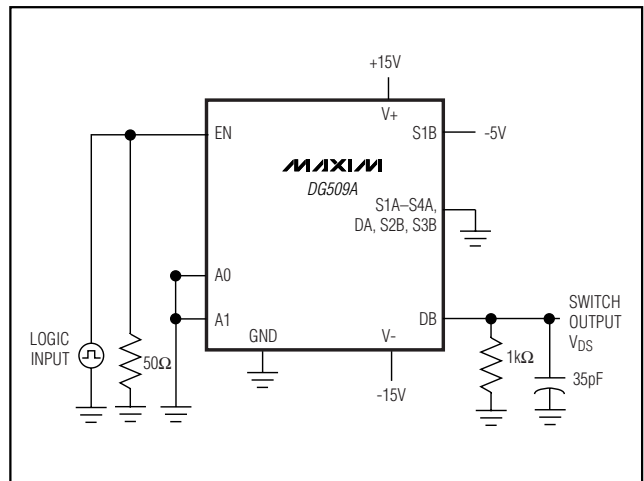

Figure 2b. DG509A Enable-Time Test Circuit

Monolithic CMOS Analog Multiplexers

DG508A/DG509A

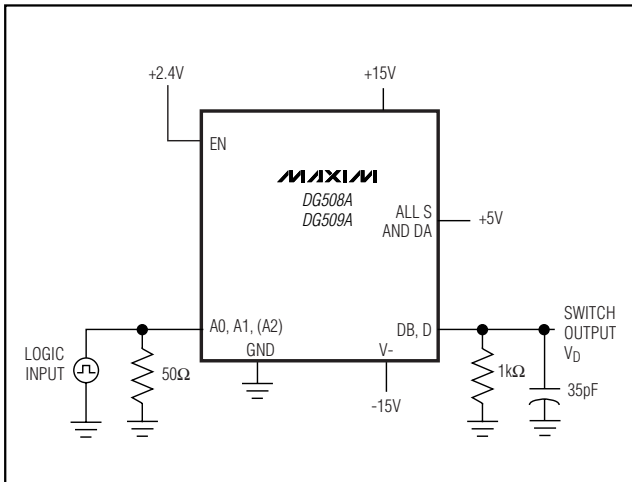

Figure 3. Break-Before-Make Test Circuit

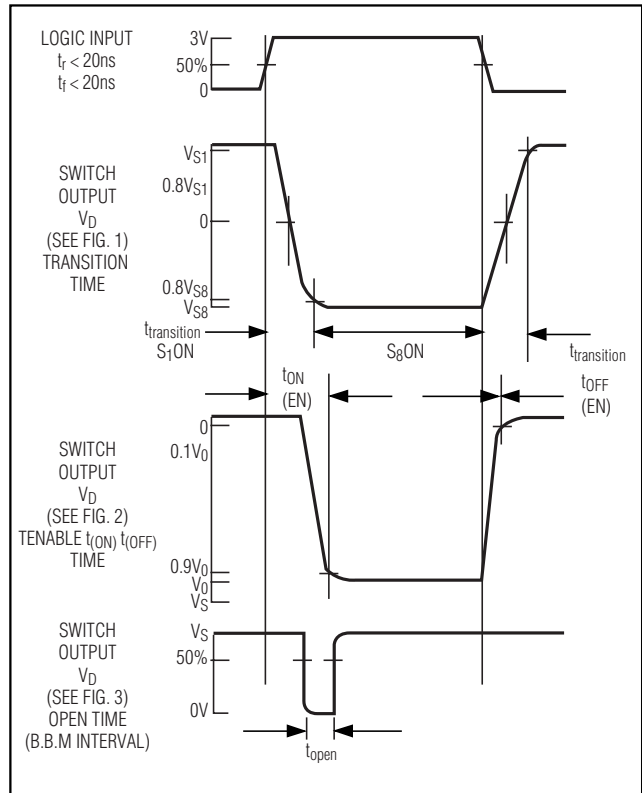

Figure 4. Timing Diagram for Figures 1, 2, and 3

Table 1a. DG508A Truth Table

A2	A1	A0	EN	ON SWITCH
X	X	X	0	NONE
0	0	0	1	1
0	0	1	1	2
0	1	0	1	3
0	1	1	1	4
1	0	0	1	5
1	0	1	1	6
1	1	0	1	7
1	1	1	1	8

X = Don't care.

Table 1 b. DG509A Truth Table

A1	A0	EN	ON SWITCH
X	X	0	NONE
0	0	1	1
0	1	1	2
1	0	1	3
1	1	1	4

X = Don't care.

Monolithic CMOS Analog Multiplexers

Typical Operating Circuits (continued)

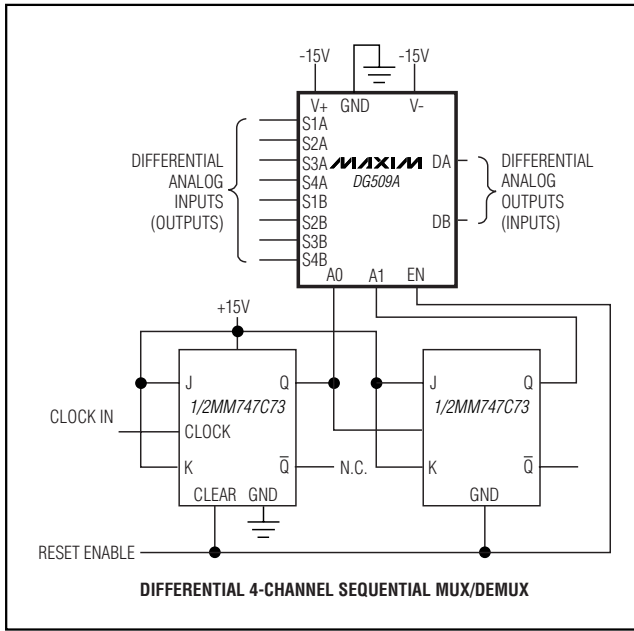

Ordering Information (continued)

PART	TEMP RANGE	PIN-PACKAGE
DG509ACJ	0°C to +70°C	16 Plastic DIP
DG509ACWE	0°C to +70°C	16 Wide SO
DG509AC/D	0°C to +70°C	Dice*
DG509ABK	-20°C to +85°C	16 CERDIP
DG509ADJ	-40°C to +85°C	16 Plastic DIP
DG509ADY	-40°C to +85°C	16 Narrow SO
DG509AEQE	-40°C to +85°C	16 QFN
DG509AEWE	-40°C to +85°C	16 Wide SO
DG509AAK	-55°C to +125°C	16 CERDIP

*Contact factory for dice specifications.

Pin Configurations (continued)

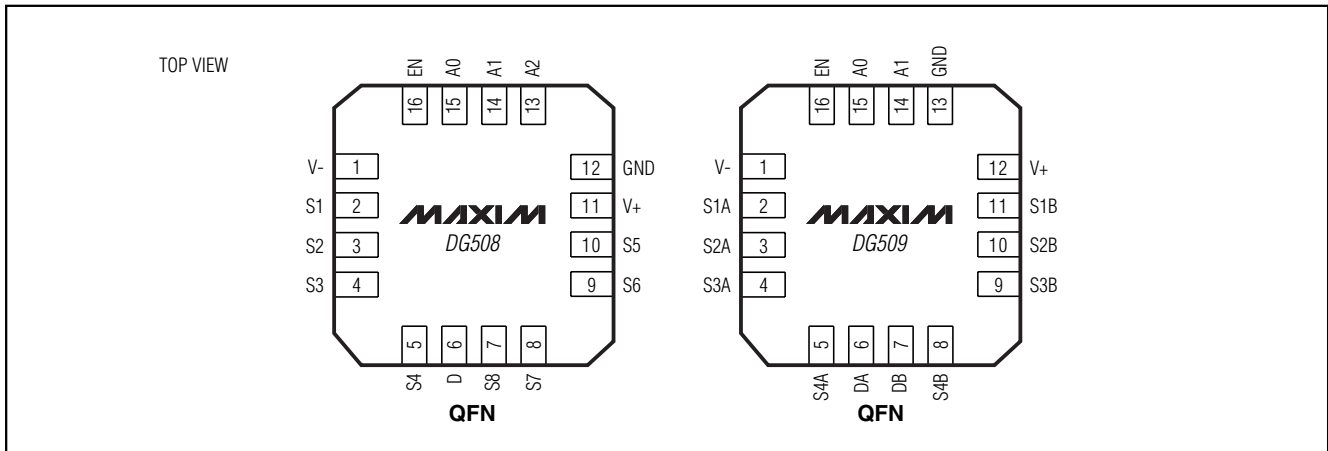

Monolithic CMOS Analog Multiplexers

Chip Topographies

DG508A/DG509A

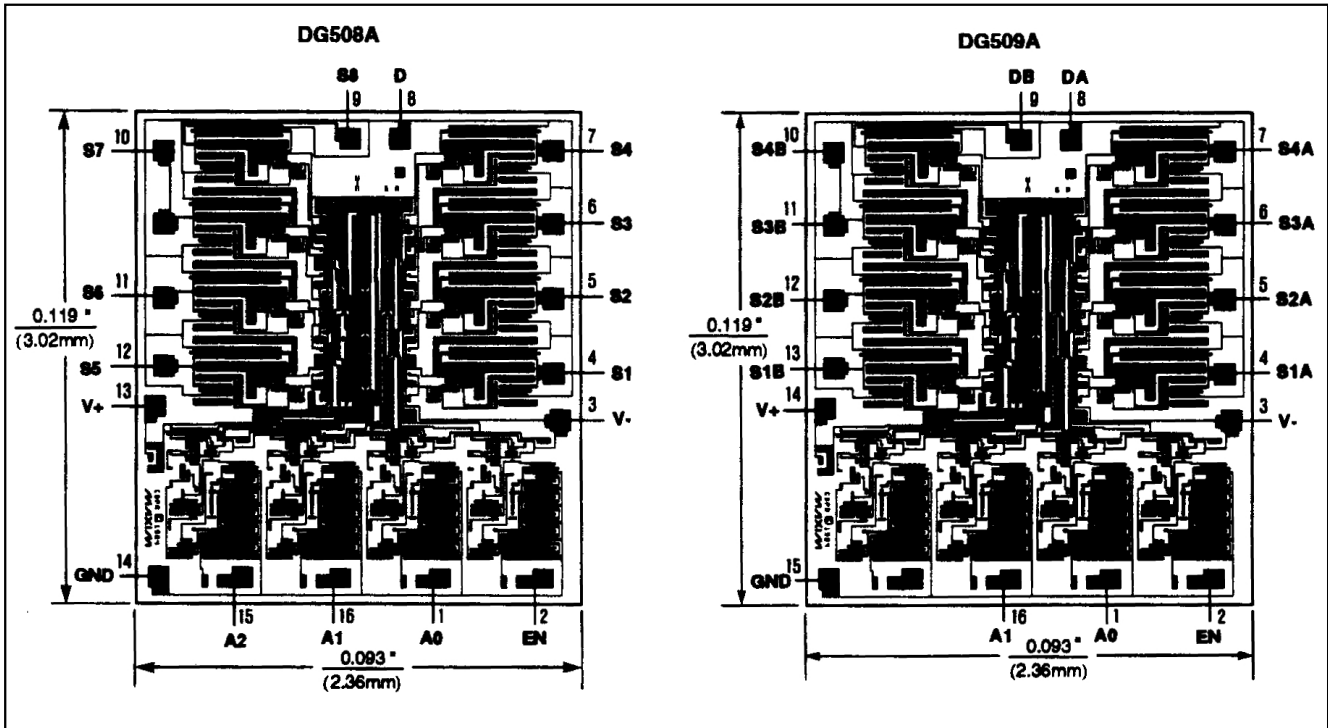

Monolithic CMOS Analog Multiplexers

Package Information

(The package drawing(s) in this data sheet may not reflect the most current specifications. For the latest package outline information go to www.maxim-ic.com/packages.)

32L QFN, EPS

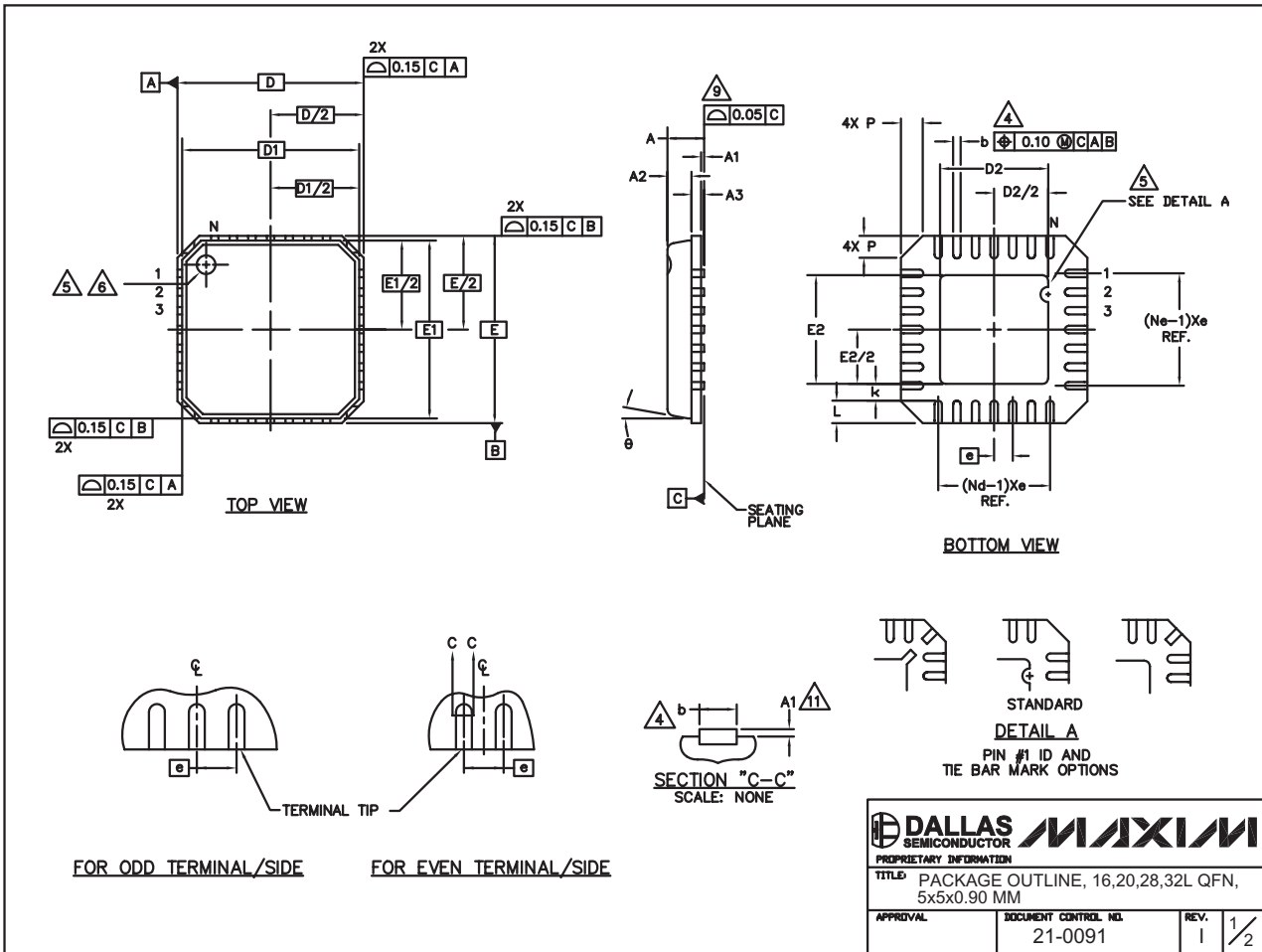

<small>PROPRIETARY INFORMATION</small>		
<small>TITLE: PACKAGE OUTLINE, 16,20,28,32L QFN, 5x5x0.90 MM</small>		
<small>APPROVAL</small>	<small>DOCUMENT CONTROL NO.</small> 21-0091	<small>REV.</small> I 1/2

Monolithic CMOS Analog Multiplexers

Package Information (continued)

(The package drawing(s) in this data sheet may not reflect the most current specifications. For the latest package outline information go to www.maxim-ic.com/packages.)

DG508A/DG509A

COMMON DIMENSIONS												
PKG	16L 5x5			20L 5x5			28L 5x5			32L 5x5		
SYMBOL	MIN.	NOM.	MAX.	MIN.	NOM.	MAX.	MIN.	NOM.	MAX.	MIN.	NOM.	MAX.
A	0.80	0.90	1.00	0.80	0.90	1.00	0.80	0.90	1.00	0.80	0.90	1.00
A1	0.00	0.01	0.05	0.00	0.01	0.05	0.00	0.01	0.05	0.00	0.01	0.05
A2	0.00	0.65	1.00	0.00	0.65	1.00	0.00	0.65	1.00	0.00	0.65	1.00
A3	0.20 REF			0.20 REF			0.20 REF			0.20 REF		
b	0.28	0.33	0.40	0.23	0.28	0.35	0.18	0.23	0.30	0.18	0.23	0.30
D	4.90	5.00	5.10	4.90	5.00	5.10	4.90	5.00	5.10	4.90	5.00	5.10
D1	4.75 BSC			4.75 BSC			4.75 BSC			4.75 BSC		
E	4.90	5.00	5.10	4.90	5.00	5.10	4.90	5.00	5.10	4.90	5.00	5.10
E1	4.75 BSC			4.75 BSC			4.75 BSC			4.75 BSC		
e	0.80 BSC			0.65 BSC			0.50 BSC			0.50 BSC		
k	0.25	-	-	0.25	-	-	0.25	-	-	0.25	-	-
L	0.35	0.55	0.75	0.35	0.55	0.75	0.35	0.55	0.75	0.30	0.40	0.50
N	16			20			28			32		
ND	4			5			7			8		
NE	4			5			7			8		
P	0.00	0.42	0.60	0.00	0.42	0.60	0.00	0.42	0.60	0.00	0.42	0.60
Ø	0"			12"			0"			12"		

EXPOSED PAD VARIATIONS						
PKG. CODES	J2			E2		
	MIN.	NOM.	MAX.	MIN.	NOM.	MAX.
G1655-3	2.95	3.10	3.25	2.95	3.10	3.25
G2055-1	2.55	2.70	2.85	2.55	2.70	2.85
G2055-2	2.95	3.10	3.25	2.95	3.10	3.25
G2855-1	2.55	2.70	2.85	2.55	2.70	2.85
G2855-2	2.95	3.10	3.25	2.95	3.10	3.25
G3255-1	2.95	3.10	3.25	2.95	3.10	3.25

NOTES:

1. DIE THICKNESS ALLOWABLE IS 0.305mm MAXIMUM (.012 INCHES MAXIMUM)
2. DIMENSIONING & TOLERANCES CONFORM TO ASME Y14.5M. - 1994.
3. N IS THE NUMBER OF TERMINALS.
Nd IS THE NUMBER OF TERMINALS IN X-DIRECTION & Ne IS THE NUMBER OF TERMINALS IN Y-DIRECTION.
4. DIMENSION b APPLIES TO PLATED TERMINAL AND IS MEASURED BETWEEN 0.20 AND 0.25mm FROM TERMINAL TIP.
5. THE PIN #1 IDENTIFIER MUST BE EXISTED ON THE TOP SURFACE OF THE PACKAGE BY USING INDENTATION MARK OR INK/LASER MARKED. DETAILS OF PIN #1 IDENTIFIER IS OPTIONAL, BUT MUST BE LOCATED WITHIN ZONE INDICATED.
6. EXACT SHAPE AND SIZE OF THIS FEATURE IS OPTIONAL.
7. ALL DIMENSIONS ARE IN MILLIMETERS.
8. PACKAGE WARPAGE MAX 0.05mm.
9. APPLIED FOR EXPOSED PAD AND TERMINALS. EXCLUDE EMBEDDED PART OF EXPOSED PAD FROM MEASURING.
10. MEETS JEDEC MO220; EXCEPT DIMENSION "b".
11. APPLIED FOR EXPOSED PAD AND TERMINALS. EXCLUDE EMBEDDING PART OF EXPOSED PAD FROM MEASURING.
12. THIS PACKAGE OUTLINE APPLIES TO ANVIL SINGULATION (STEPPED SIDES).

<small>PROPRIETARY INFORMATION</small>	
TITLE: PACKAGE OUTLINE, 16,20,28,32L QFN, 5x5x0.90 MM	
APPROVAL	DOCUMENT CONTROL NO. 21-0091
REV. 1	2/2

Maxim cannot assume responsibility for use of any circuitry other than circuitry entirely embodied in a Maxim product. No circuit patent licenses are implied. Maxim reserves the right to change the circuitry and specifications without notice at any time.

Maxim Integrated Products, 120 San Gabriel Drive, Sunnyvale, CA 94086 408-737-7600 _____ 11



LittleDiode supplies new, hard to find or obsolete electronic components and semiconductors all over the world.

With over two million different components listed you are sure to find the part you need.

Feel free to visit us today at our online store:

LittleDiode.com

Looking forward to providing you with the best possible service.