

DM54L74 Dual Positive-Edge-Triggered D Flip-Flops with Preset, Clear, and Complementary Outputs

General Description

This device contains two independent positive-edge-triggered D flip-flops with complementary outputs. The information on the D input is accepted by the flip-flops on the positive going edge of the clock pulse. The triggering occurs at a voltage level and is not directly related to the transition time of the rising edge of the clock. The data on the D input

may be changed while the clock is low or high without affecting the outputs as long as the data setup and hold times are not violated. A low logic level on the preset or clear inputs will set or reset the outputs regardless of the logic levels of the other inputs.

Connection Diagram

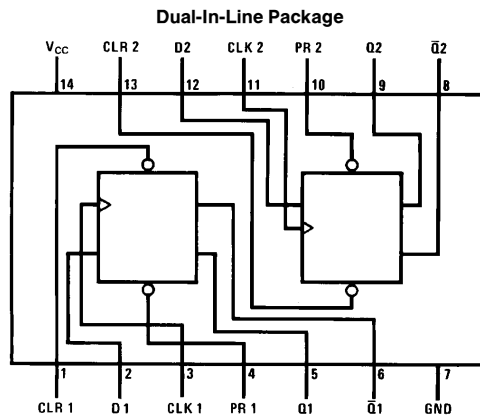

TL/F/6631-1

Order Number DM54L74J or DM54L74W
See NS Package Number J14A or W14B

Function Table

Inputs				Outputs	
PR	CLR	CLK	D	Q	\bar{Q}
L	H	X	X	H	L
H	L	X	X	L	H
L	L	X	X	H*	H*
H	H	↑	H	H	L
H	H	↑	L	L	H
H	H	L	X	Q _O	\bar{Q} _O

H = High Logic Level

X = Either Low or High Logic Level

L = Low Logic Level

↑ = Positive-going transition.

Q_O = The output logic level of Q before the indicated input conditions were established.

* = This configuration is nonstable; that is, it will not persist when either the preset and/or clear inputs returned to their inactive (high) level.

DM54L74 Dual Positive-Edge-Triggered D Flip-Flops with Preset, Clear, and Complementary Outputs

Absolute Maximum Ratings (Note)

If Military/Aerospace specified devices are required, please contact the National Semiconductor Sales Office/Distributors for availability and specifications.

Supply Voltage	8V
Input Voltage	5.5V
Operating Free Air Temperature Range	
DM54L	–55°C to +125°C
Storage Temperature Range	–65°C to +150°C

Note: The “Absolute Maximum Ratings” are those values beyond which the safety of the device cannot be guaranteed. The device should not be operated at these limits. The parametric values defined in the “Electrical Characteristics” table are not guaranteed at the absolute maximum ratings. The “Recommended Operating Conditions” table will define the conditions for actual device operation.

Recommended Operating Conditions

Symbol	Parameter	DM54L74			Units
		Min	Nom	Max	
V _{CC}	Supply Voltage	4.5	5	5.5	V
V _{IH}	High Level Input Voltage	2			V
V _{IL}	Low Level Input Voltage			0.7	V
I _{OH}	High Level Output Current			–0.2	mA
I _{OL}	Low Level Output Current			2	mA
f _{CLK}	Clock Frequency (Note 2)	0		6	MHz
t _w	Pulse Width (Note 2)	Clock High	75		ns
		Clock Low	75		
		Preset Low	75		
		Clear Low	75		
t _{SU}	Input Setup Time (Notes 1 & 2)	50 ↑			ns
t _H	Input Hold Time (Notes 1 & 2)	15 ↑			ns
T _A	Free Air Operating Temperature	–55		125	°C

Note 1: The symbol (↑) indicates the rising edge of the clock pulse is used for reference.

Note 2: T_A = 25°C and V_{CC} = 5V.

Electrical Characteristics

over recommended operating free air temperature (unless otherwise noted)

Symbol	Parameter	Conditions	Min	Typ (Note 1)	Max	Units
V_{OH}	High Level Output Voltage	$V_{CC} = \text{Min}, I_{OH} = \text{Max}$ $V_{IL} = \text{Max}, V_{IH} = \text{Min}$	2.4	3.3		V
V_{OL}	Low Level Output Voltage	$V_{CC} = \text{Min}, I_{OL} = \text{Max}$ $V_{IL} = \text{Max}, V_{IH} = \text{Min}$		0.15	0.3	V
I_I	Input Current @ Max Input Voltage	$V_{CC} = \text{Max}$ $V_I = 5.5V$	D		100	μA
			Clear		300	
			Preset		200	
			Clock		200	
I_{IH}	High Level Input Current	$V_{CC} = \text{Max}$ $V_I = 2.4V$	D		10	μA
			Clear		30	
			Preset		20	
			Clock		20	
I_{IL}	Low Level Input Current	$V_{CC} = \text{Max}$ $V_I = 0.3V$	D		-0.18	mA
			Clear		-0.36	
			Preset		-0.18	
			Clock		-0.36	
I_{OS}	Short Circuit Output Current	$V_{CC} = \text{Max}$	-3		-15	mA
I_{CC}	Supply Current	$V_{CC} = \text{Max}$ (Note 2)		1.6	3	mA

Note 1: All typicals are at $V_{CC} = 5V, T_A = 25^\circ C$.

Note 2: With all outputs open, I_{CC} is measured with the Q and \bar{Q} outputs high in turn. At the time of measurement, the clock input is grounded.

Switching Characteristics

at $V_{CC} = 5V$ and $T_A = 25^\circ C$ (See Section 1 for Test Waveforms and Output Load)

Symbol	Parameter	From (Input) To (Output)	$R_L = 4\text{ k}\Omega, C_L = 50\text{ pF}$		Units
			Min	Max	
f_{MAX}	Maximum Clock Frequency		6		MHz
t_{PLH}	Propagation Delay Time Low to High Level Output	Preset to Q		60	ns
t_{PHL}	Propagation Delay Time High to Low Level Output	Preset to \bar{Q}		120	ns
t_{PLH}	Propagation Delay Time Low to High Level Output	Clear to \bar{Q}		60	ns
t_{PHL}	Propagation Delay Time High to Low Level Output	Clear to Q		120	ns
t_{PLH}	Propagation Delay Time Low to High Level Output	Clock to Q or \bar{Q}	10	90	ns
t_{PHL}	Propagation Delay Time High to Low Level Output	Clock to Q or \bar{Q}	10	120	ns

DM54L74 Dual Positive-Edge-Triggered D Flip-Flops with Preset, Clear, and Complementary Outputs

Physical Dimensions inches (millimeters)

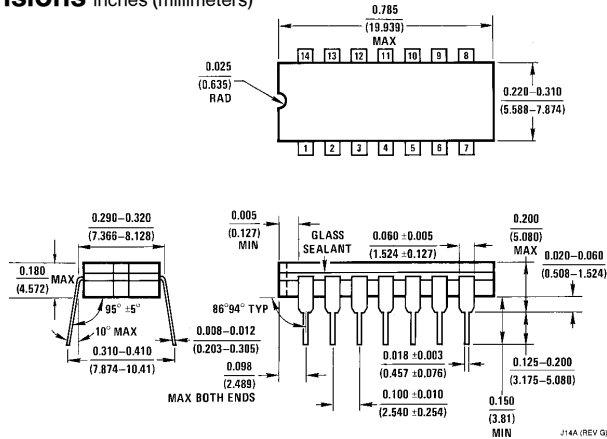

14-Lead Ceramic Dual-In-Line Package (J)
Order Number DM54L74J
NS Package Number J14A

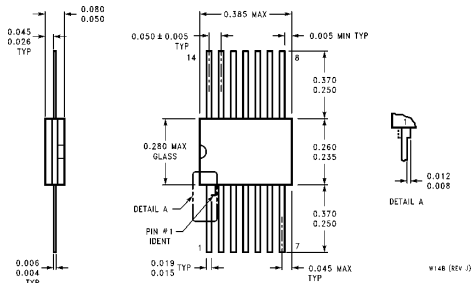

14-Lead Ceramic Flat Package (W)
Order Number DM54L74W
NS Package Number W14B

LIFE SUPPORT POLICY

NATIONAL'S PRODUCTS ARE NOT AUTHORIZED FOR USE AS CRITICAL COMPONENTS IN LIFE SUPPORT DEVICES OR SYSTEMS WITHOUT THE EXPRESS WRITTEN APPROVAL OF THE PRESIDENT OF NATIONAL SEMICONDUCTOR CORPORATION. As used herein:

1. Life support devices or systems are devices or systems which, (a) are intended for surgical implant into the body, or (b) support or sustain life, and whose failure to perform, when properly used in accordance with instructions for use provided in the labeling, can be reasonably expected to result in a significant injury to the user.
2. A critical component is any component of a life support device or system whose failure to perform can be reasonably expected to cause the failure of the life support device or system, or to affect its safety or effectiveness.



National Semiconductor Corporation
 1111 West Bardin Road
 Arlington, TX 76017
 Tel: 1(800) 272-9959
 Fax: 1(800) 737-7018

National Semiconductor Europe
 Fax: (+49) 0-180-530 85 86
 Email: cnjwge@tevm2.nsc.com
 Deutsch Tel: (+49) 0-180-530 85 85
 English Tel: (+49) 0-180-532 78 32
 Français Tel: (+49) 0-180-532 93 58
 Italiano Tel: (+49) 0-180-534 16 80

National Semiconductor Hong Kong Ltd.
 19th Floor, Straight Block,
 Ocean Centre, 5 Canton Rd.
 Tsimshatsui, Kowloon
 Hong Kong
 Tel: (852) 2737-1600
 Fax: (852) 2736-9960

National Semiconductor Japan Ltd.
 Tel: 81-043-299-2309
 Fax: 81-043-299-2408

National does not assume any responsibility for use of any circuitry described, no circuit patent licenses are implied and National reserves the right at any time without notice to change said circuitry and specifications.

This datasheet has been downloaded from:

www.DatasheetCatalog.com

Datasheets for electronic components.

National Semiconductor was acquired by Texas Instruments.

http://www.ti.com/corp/docs/investor_relations/pr_09_23_2011_national_semiconductor.html

This file is the datasheet for the following electronic components:

DM54L74W - <http://www.ti.com/product/dm54l74w?HQS=TI-null-null-dscatalog-df-pf-null-ww>

DM54L74J - <http://www.ti.com/product/dm54l74j?HQS=TI-null-null-dscatalog-df-pf-null-ww>



LittleDiode supplies new, hard to find or obsolete electronic components and semiconductors all over the world.

With over two million different components listed you are sure to find the part you need.

Feel free to visit us today at our online store:

LittleDiode.com

Looking forward to providing you with the best possible service.