

DM7414

Hex Inverter with Schmitt Trigger Input

General Description

This device contains six independent gates each of which performs the logic INVERT function. Each input has hysteresis which increases the noise immunity and transforms a slowly changing input signal to a fast changing, jitter free output.

Ordering Code:

Order Number	Package Number	Package Description
DM7414N	N14A	14-Lead Plastic Dual-In-Line Package (PDIP), JEDEC MS-001, 0.300 Wide

Connection Diagram

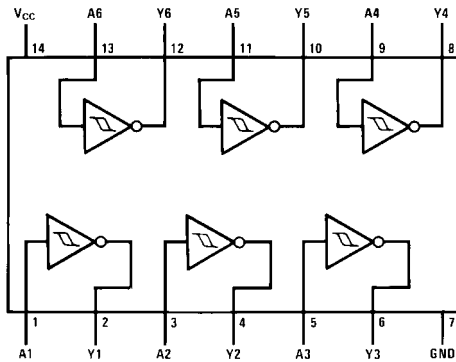

Function Table

$$Y = \bar{A}$$

Input	Output
A	Y
L	H
H	L

H = HIGH Logic Level
L = LOW Logic Level

Absolute Maximum Ratings(Note 1)

Supply Voltage	7V
Input Voltage	5.5V
Operating Free Air Temperature Range	0°C to +70°C
Storage Temperature Range	-65°C to +150°C

Note 1: The "Absolute Maximum Ratings" are those values beyond which the safety of the device cannot be guaranteed. The device should not be operated at these limits. The parametric values defined in the Electrical Characteristics tables are not guaranteed at the absolute maximum ratings. The "Recommended Operating Conditions" table will define the conditions for actual device operation.

Recommended Operating Conditions

Symbol	Parameter	Min	Nom	Max	Units
V_{CC}	Supply Voltage	4.75	5	5.25	V
V_{T+}	Positive-Going Input Threshold Voltage (Note 2)	1.5	1.7	2	V
V_{T-}	Negative-Going Input Threshold Voltage (Note 2)	0.6	0.9	1.1	V
HYS	Input Hysteresis (Note 2)	0.4	0.8		V
I_{OH}	High Level Output Current			-0.8	mA
I_{OL}	Low Level Output Current			16	mA
T_A	Free Air Operating Temperature	0		70	°C

Note 2: $V_{CC} = 5V$

Electrical Characteristics

over recommended operating free air temperature range (unless otherwise noted)

Symbol	Parameter	Conditions	Min	Typ (Note 3)	Max	Units
V_I	Input Clamp Voltage	$V_{CC} = \text{Min}, I_I = -12 \text{ mA}$			-1.5	V
V_{OH}	HIGH Level Output Voltage	$V_{CC} = \text{Min}, I_{OH} = \text{Max}$ $V_I = V_{T-\text{Min}}$	2.4	3.4		V
V_{OL}	LOW Level Output Voltage	$V_{CC} = \text{Min}, I_{OL} = \text{Max}$ $V_I = V_{T+\text{Max}}$		0.2	0.4	V
I_{T+}	Input Current at Positive-Going Threshold	$V_{CC} = 5V, V_I = V_{T+}$		-0.43		mA
I_{T-}	Input Current at Negative-Going Threshold	$V_{CC} = 5V, V_I = V_{T-}$		-0.56		mA
I_I	Input Current @ Max Input Voltage	$V_{CC} = \text{Max}, V_I = 5.5V$			1	mA
I_{IH}	HIGH Level Input Current	$V_{CC} = \text{Max}, V_I = 2.4V$			40	μA
I_{IL}	LOW Level Input Current	$V_{CC} = \text{Max}, V_I = 0.4V$			-1.2	mA
I_{OS}	Short Circuit Output Current	$V_{CC} = \text{Max}$ (Note 4)	-18		-55	mA
I_{CCH}	Supply Current with Outputs HIGH	$V_{CC} = \text{Max}$		22	36	mA
I_{CCL}	Supply Current with Outputs LOW	$V_{CC} = \text{Max}$		39	60	mA

Note 3: All typicals are at $V_{CC} = 5V, T_A = 25^\circ\text{C}$.

Note 4: Not more than one output should be shorted at a time.

Switching Characteristics

at $V_{CC} = 5V$ and $T_A = 25^\circ\text{C}$

Symbol	Parameter	Conditions	Min	Max	Units
t_{PLH}	Propagation Delay Time LOW-to-HIGH Level Output	$C_L = 15 \text{ pF}$ $R_L = 400\Omega$		22	ns
t_{PHL}	Propagation Delay Time HIGH-to-LOW Level Output			22	ns

Physical Dimensions inches (millimeters) unless otherwise noted

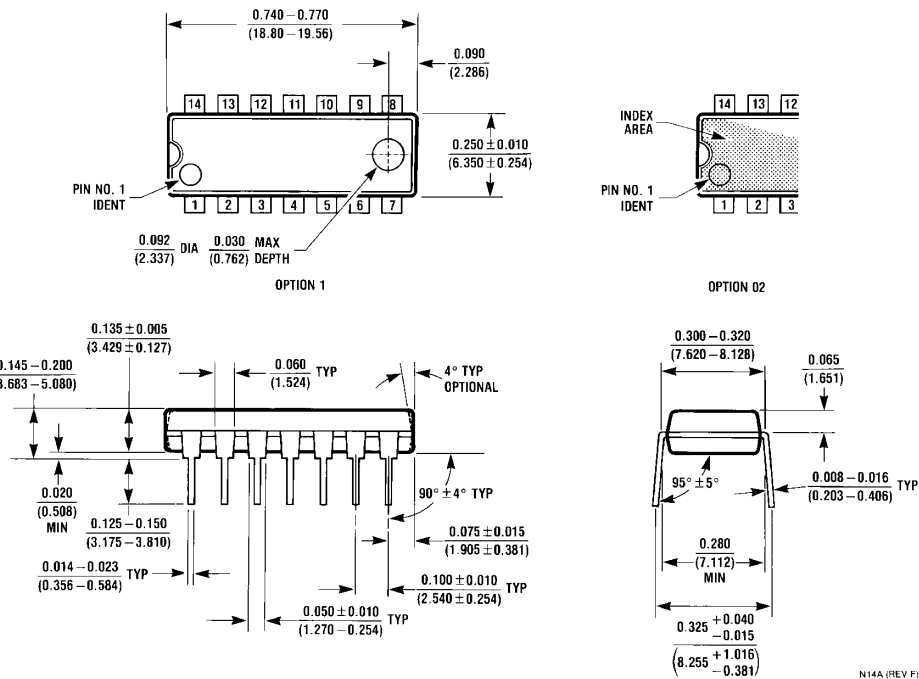

14-Lead Plastic Dual-In-Line Package (PDIP), JEDEC MS-001, 0.300 Wide Package Number N14A

Fairchild does not assume any responsibility for use of any circuitry described, no circuit patent licenses are implied and Fairchild reserves the right at any time without notice to change said circuitry and specifications.

LIFE SUPPORT POLICY

FAIRCHILD'S PRODUCTS ARE NOT AUTHORIZED FOR USE AS CRITICAL COMPONENTS IN LIFE SUPPORT DEVICES OR SYSTEMS WITHOUT THE EXPRESS WRITTEN APPROVAL OF THE PRESIDENT OF FAIRCHILD SEMICONDUCTOR CORPORATION. As used herein:

1. Life support devices or systems are devices or systems which, (a) are intended for surgical implant into the body, or (b) support or sustain life, and (c) whose failure to perform when properly used in accordance with instructions for use provided in the labeling, can be reasonably expected to result in a significant injury to the user.
2. A critical component in any component of a life support device or system whose failure to perform can be reasonably expected to cause the failure of the life support device or system, or to affect its safety or effectiveness.

www.fairchildsemi.com

This datasheet has been downloaded from:

www.DatasheetCatalog.com

Datasheets for electronic components.



LittleDiode supplies new, hard to find or obsolete electronic components and semiconductors all over the world.

With over two million different components listed you are sure to find the part you need.

Feel free to visit us today at our online store:

LittleDiode.com

Looking forward to providing you with the best possible service.