

### FEATURES

- Small size, low-cost interface to an RS232C COM Port for reading and writing iButton devices
- Supports reading all and writing non-EPROM iButton devices at regular speed
- Powered entirely from an RS232 interface
- Standard DB female connector for mating to the COM Port of a computer with a DS9098 iButton Retainer for a single iButton or MicroLAN Cable (DS1402x)

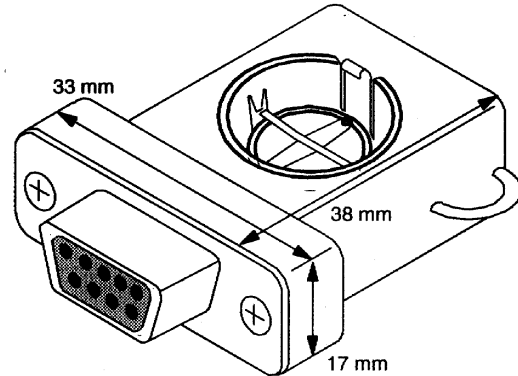

### SCHEMATIC

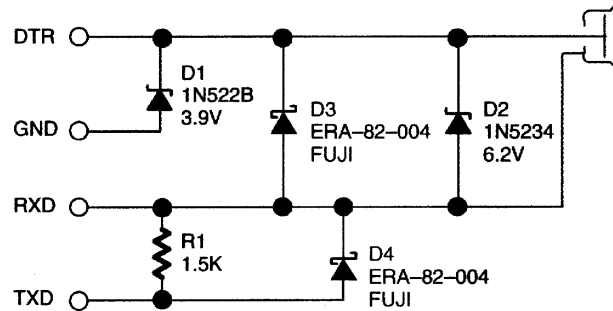

### ORDERING INFORMATION

DS1413      DB-9 Connector

### DESCRIPTION

The DS1413 Passive Serial Port iButton Holder is a simple, lowcost adapter which performs RS232C ( $\pm 12V$ ) level conversion, allowing a non-EPROM iButton to be read and written directly. It can also read all EPROM based iButtons. The serial port must support a data transmission rate of 115.2 kbits/s in order to create the 1-Wire time slots correctly. Nearly all PCs and several other hardware platforms support the required bit rate and are fully compatible with the DS1413. Since an eight bit character (6 data bits plus start-and stop bit) on the RS232C port operating at 115.2 kbits/s is used to form a single 1-Wire time slot, the maximum effective 1-Wire transfer rate is 14.4 kbits/s (regular speed). The DS1413 has a DS9098 retainer for a single F5 Micro-Can and can replace the DS9097 COM Port Adapter in applications that use only a single iButton. Multiple iButtons can be connected to the DS1413 using standard MicroLAN Cables and button holders (see DS1401 and DS1402x data sheets).

The DS1413 does not support the strong pullup which is required to run the Crypto iButton. For applications requiring a strong 5V pullup see DS1411. Details on the operation of the DS1413 are found in Application Note 74, Section V.



LittleDiode supplies new, hard to find or obsolete electronic components and semiconductors all over the world.

With over two million different components listed you are sure to find the part you need.

Feel free to visit us today at our online store:

[LittleDiode.com](http://LittleDiode.com)

Looking forward to providing you with the best possible service.