

BU508D



2022

NPN Triple Diffused Planar Silicon Transistor

T-33-11

Horizontal Output Applications

Absolute Maximum Ratings at Ta=25°C

Parameter	Symbol	Value	unit
Collector to Base Voltage	V _{CB0}	1500	V
Collector to Emitter Voltage	V _{CE0}	800	V
Emitter to Base Voltage	V _{EB0}	6	V
Collector Current	I _C	5	A
Peak Collector Current	i _{cp}	16	A
Collector Dissipation	P _C	50	W
Junction Temperature	T _j	150	°C
Storage Temperature	T _{stg}	-55 to +150	°C

Electrical Characteristics at Ta=25°C

Parameter	Symbol	Test Conditions	min	typ	max	unit
Collector Cutoff Current	I _{CES}	V _{CE} =1500V, V _{BE} =0			1	mA
Emitter Cutoff Current	I _{EBO}	V _{EB} =6V, I _C =0			200	mA
C-E Saturation Voltage	V _{CE(sat)}	I _C =4.5A, I _B =2A			1	V
B-E Saturation Voltage	V _{BE(sat)}	I _C =4.5A, I _B =2A			1.3	V
Gain Bandwidth Product	f _T	V _{CE} =5V, I _C =0.1A, f=5MHz		7		MHz
C-E Sustaining Voltage	V _{CEO(sus)}	I _C =100mA, L=25mH	800			V
Fall-Time	t _f	I _C =4A, I _{B1} =0.8A I _{B2} =-1.6A			0.4	us
Forward Voltage (Damper Diode)	V _F	I _{EC} =5A	1.4	2.0		V
DC Current Gain	h _{FE}	V _{CE} =5V, I _C =4.5A	2.25			

Switching Time Test Circuit

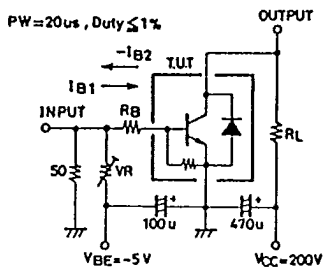

Case Outline 2022 (unit:mm)

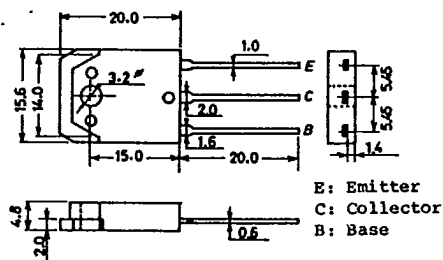

6057KI/9114KI,TS BU508D-1/3

1831

BU508D

T-33-11

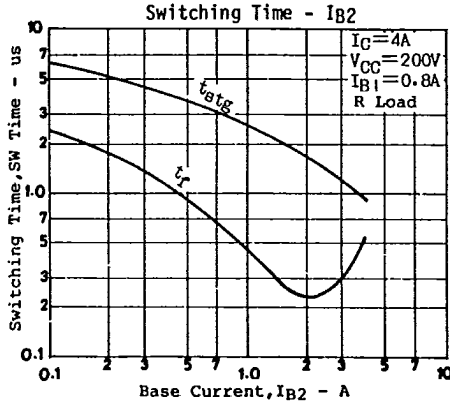
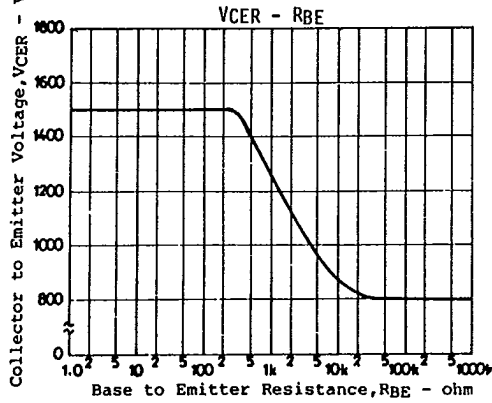
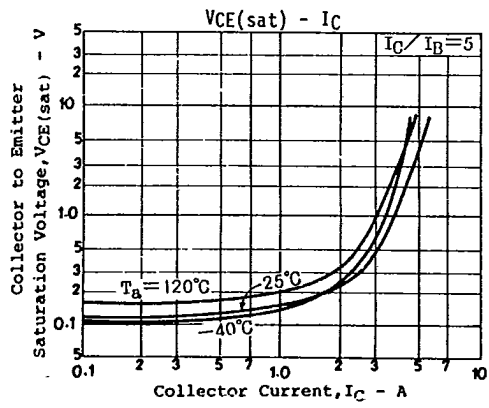
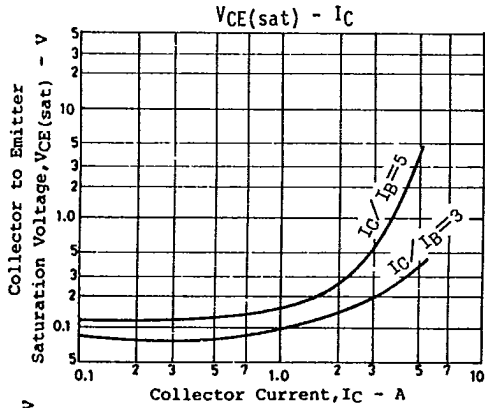
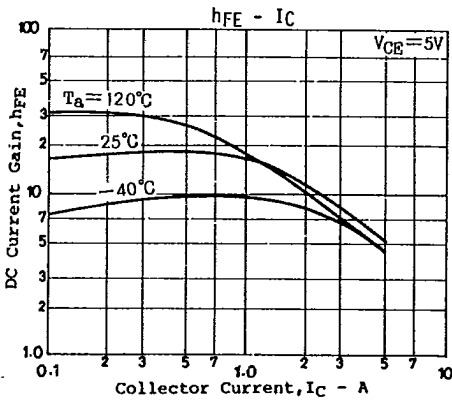
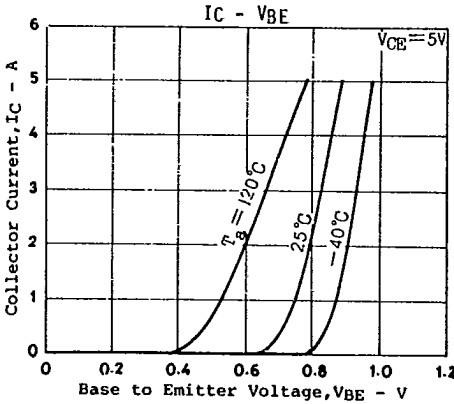
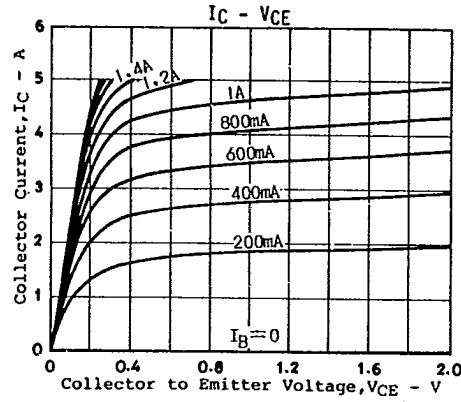
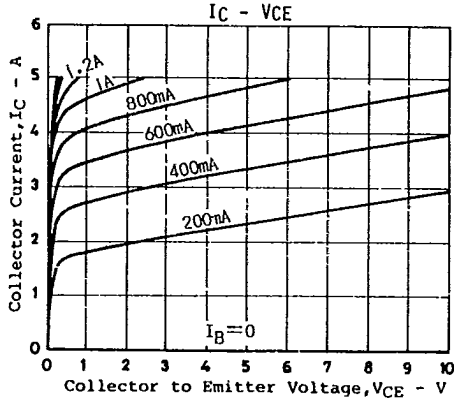

1832

BU508D

T-33-11

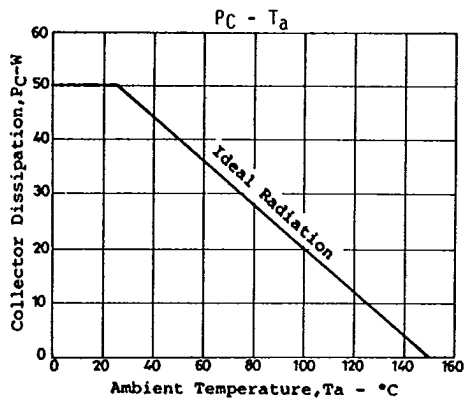
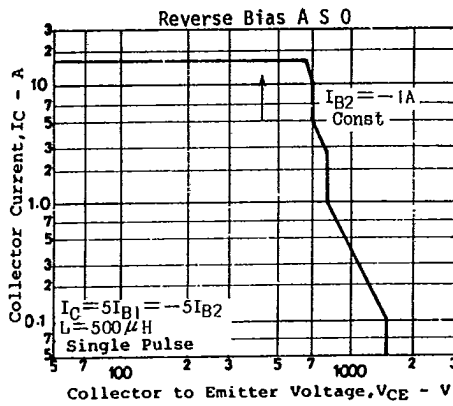
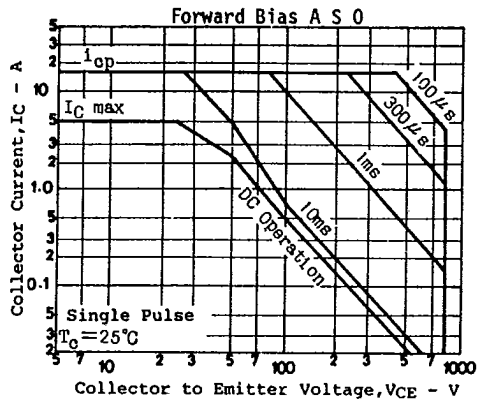

Sample Application Circuit

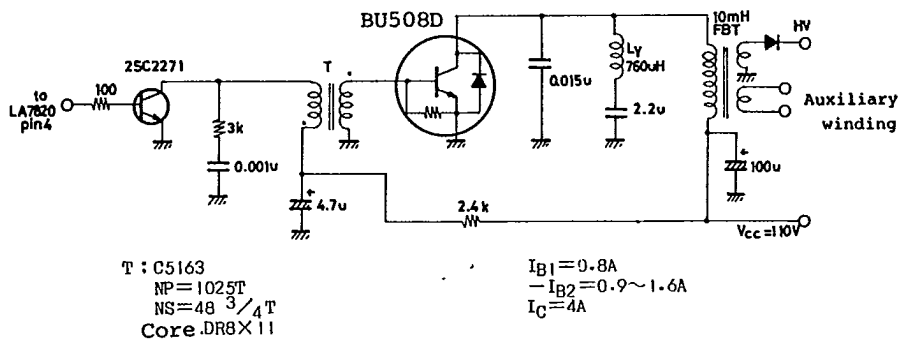

CASE OUTLINES AND ATTACHMENTS

- All of Sanyo Transistor case outlines are illustrated below.
- All dimensions are in mm, and dimensions which are not followed by min. or max. are represented by typical values.
- No marking is indicated.

Case Outline-[2003A]
unit:mm

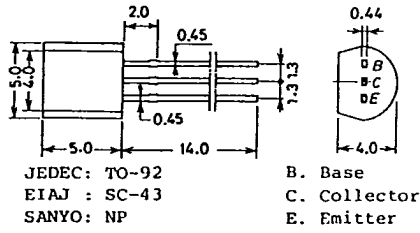

Case Outline-[2009A]
unit:mm

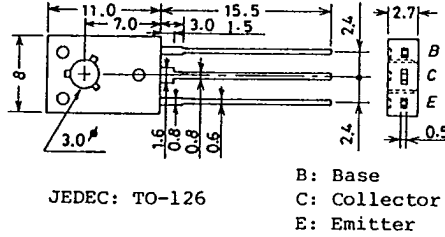

Case Outline-[2004A]
unit:mm

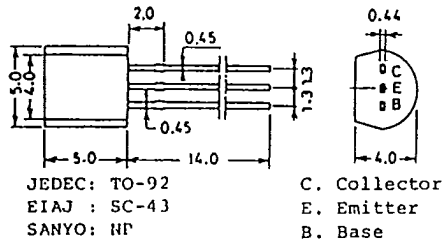

Case Outline-[2010A]
unit:mm

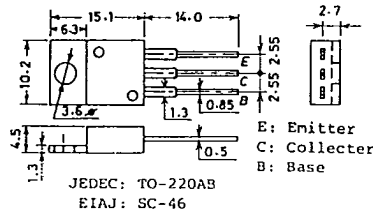

Case Outline-[2005A]
unit:mm

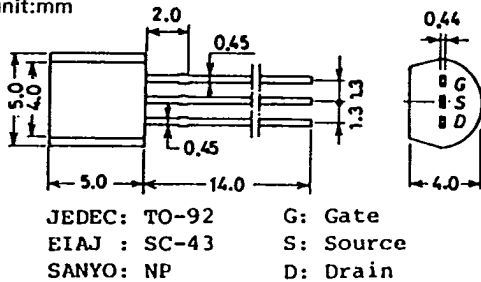

Case Outline-[2012]
unit:mm

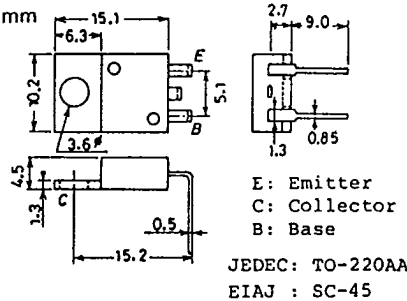

Case Outline-[2006A]
unit:mm

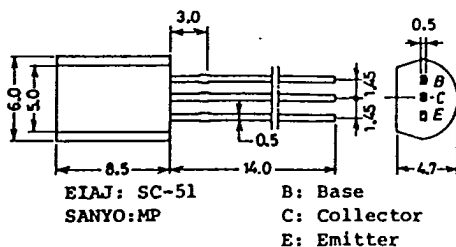

Case Outline-[2013]
unit:mm

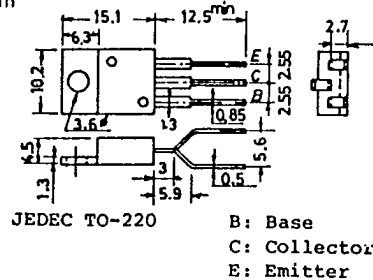

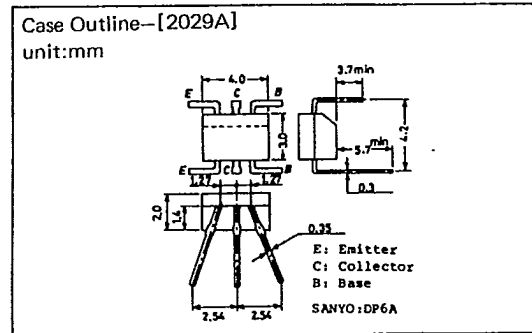
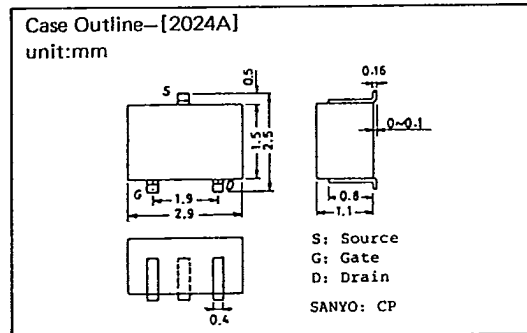
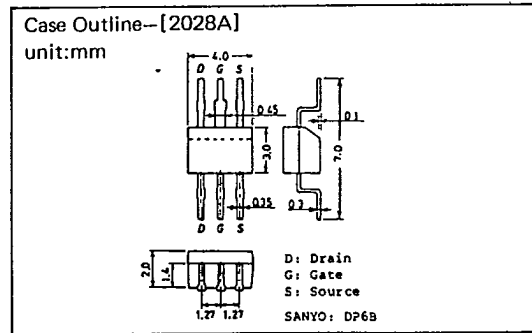
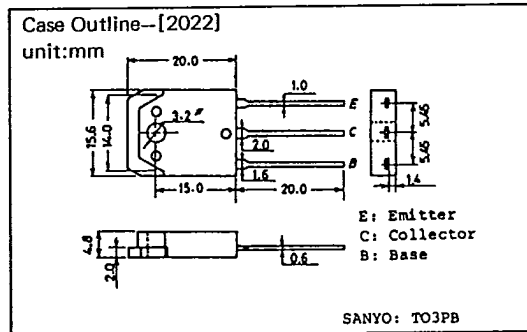
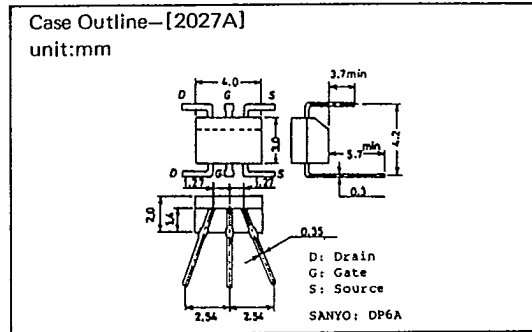
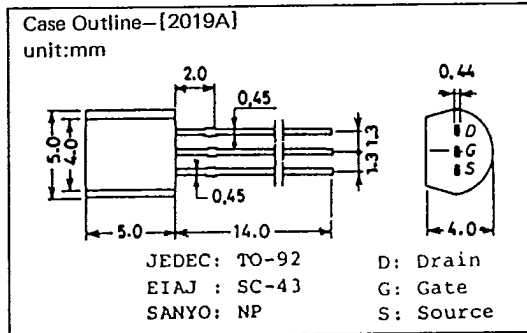
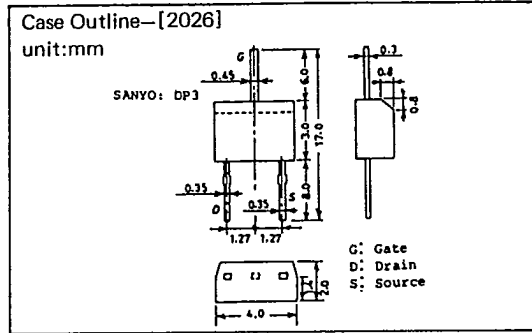
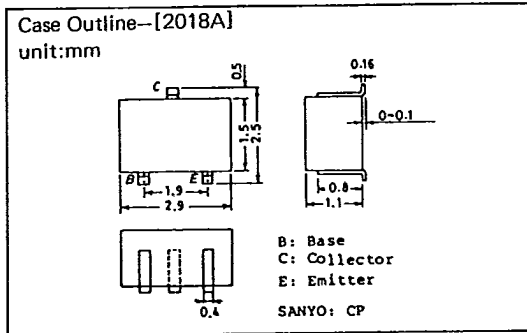
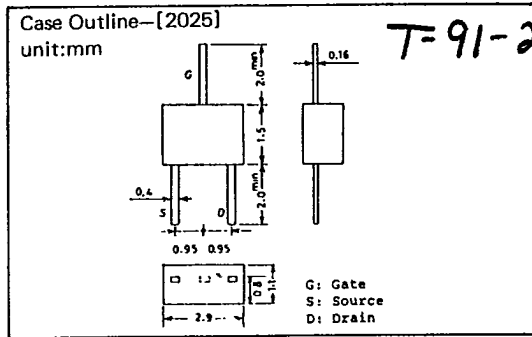
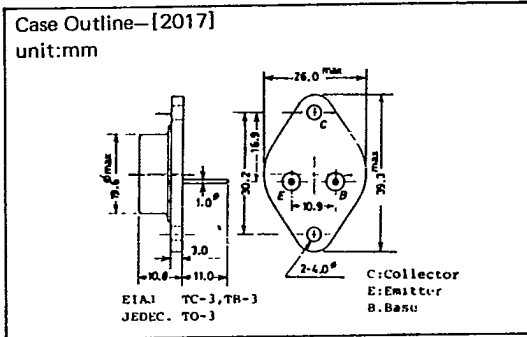

T-91-20

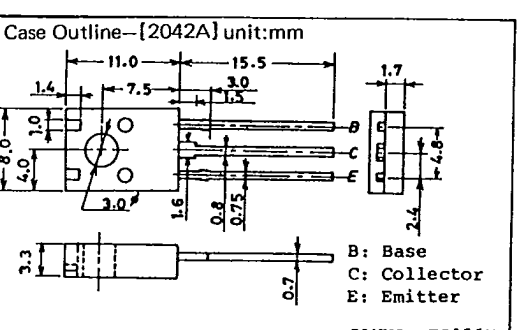
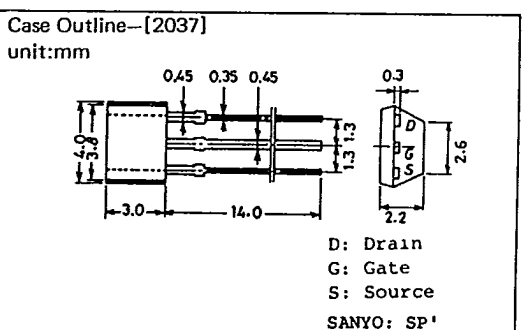
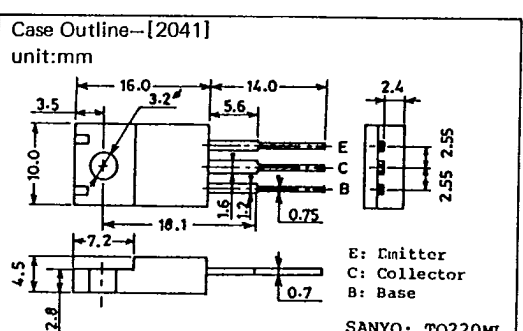
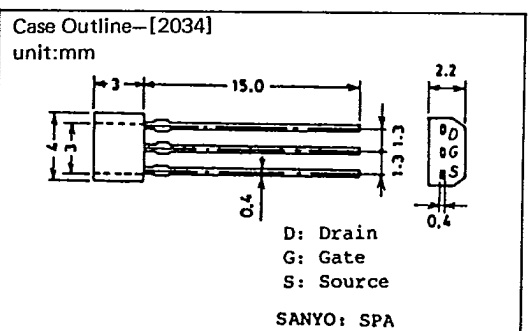
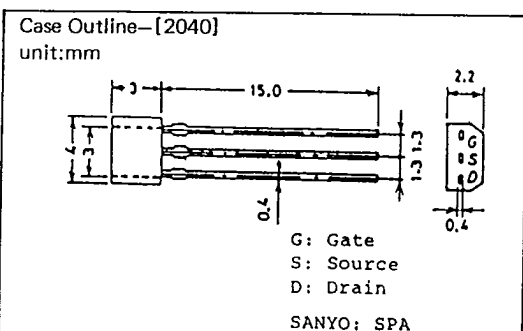
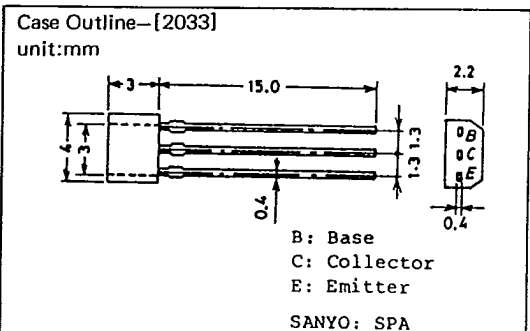
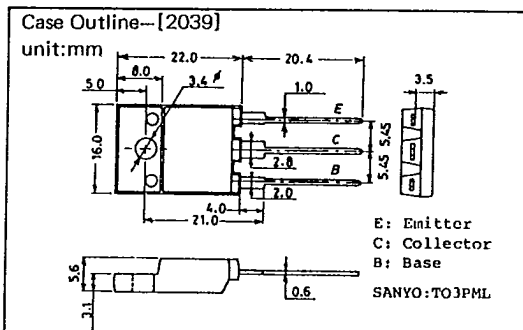
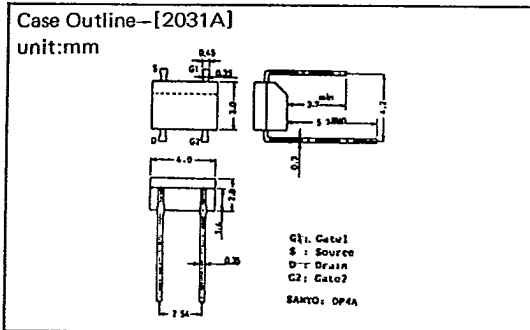
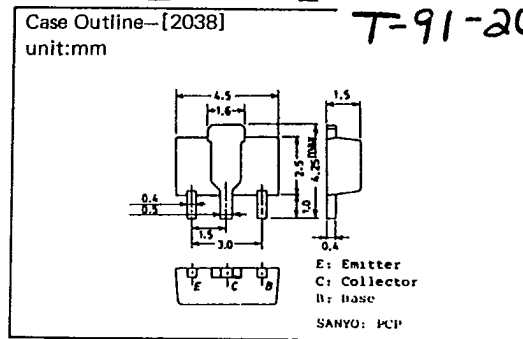
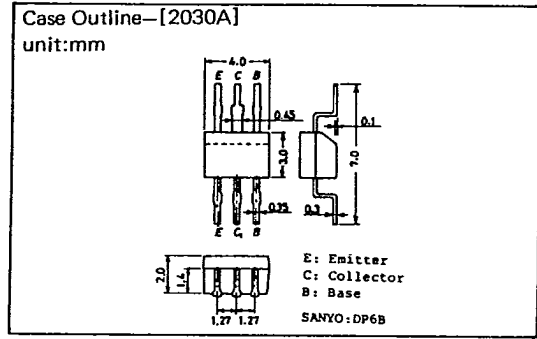

T-91-20

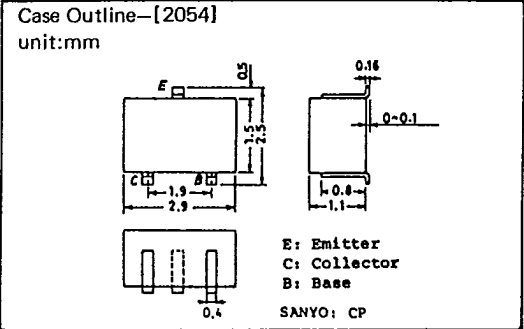
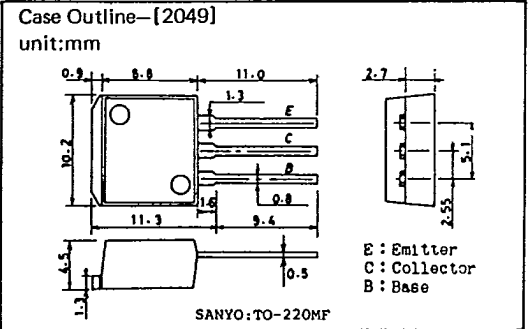
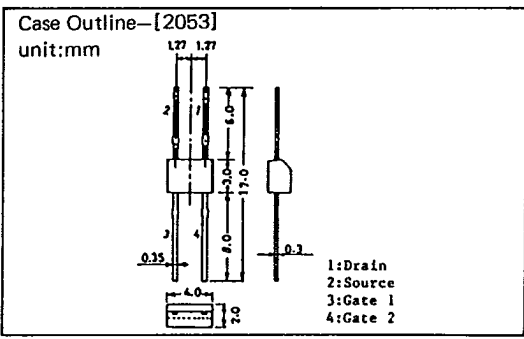
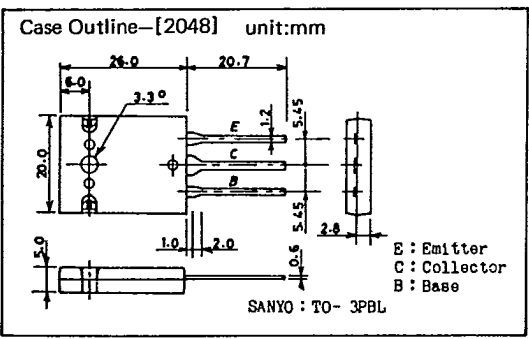
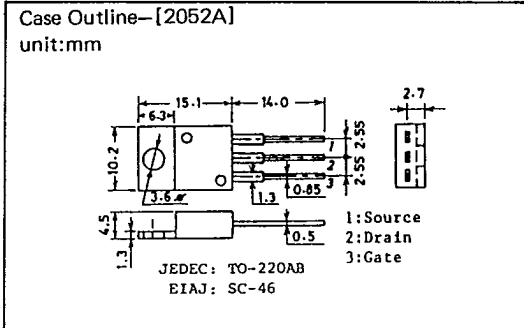
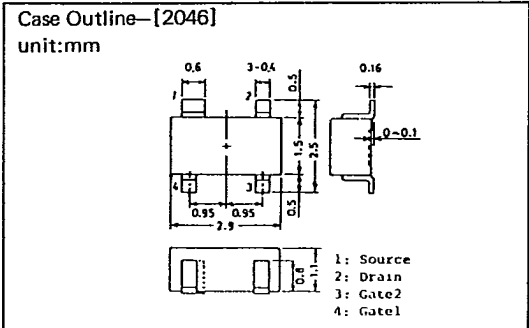
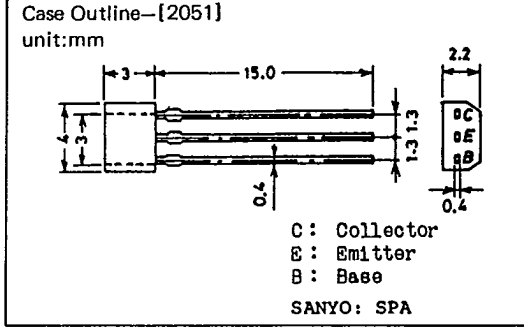
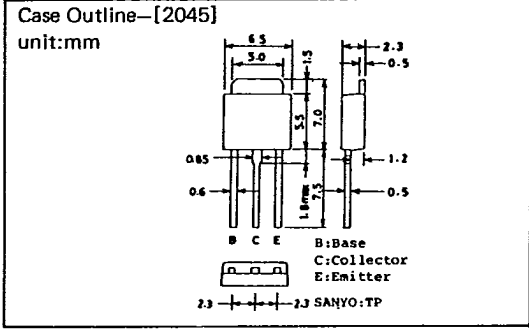
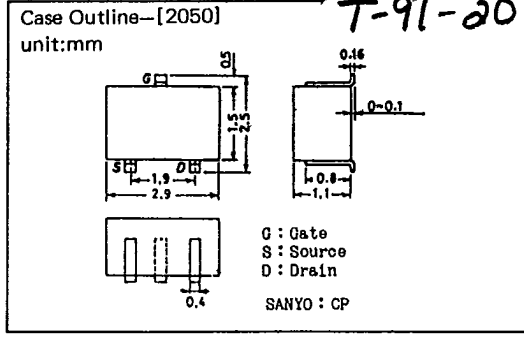
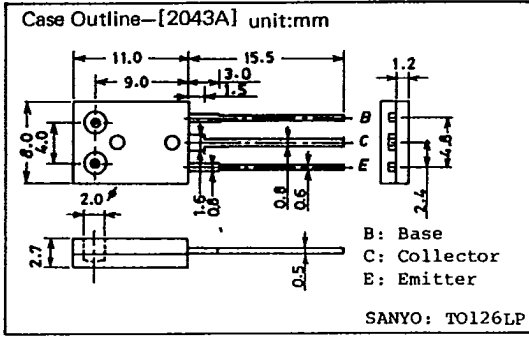

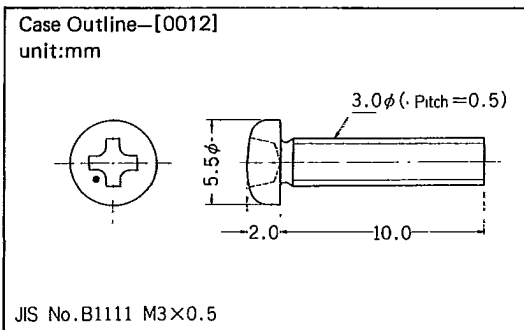
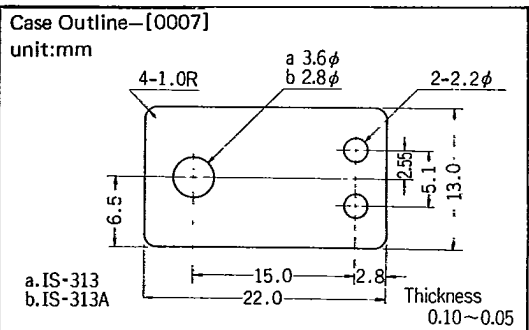
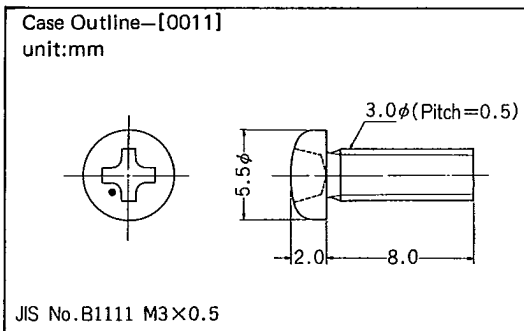
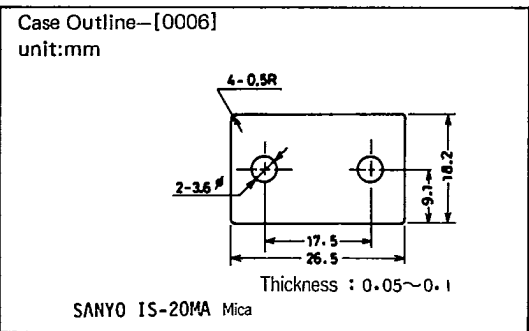
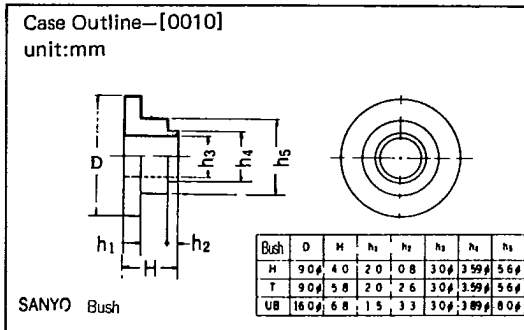
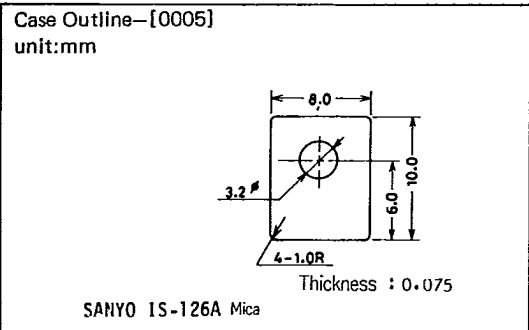
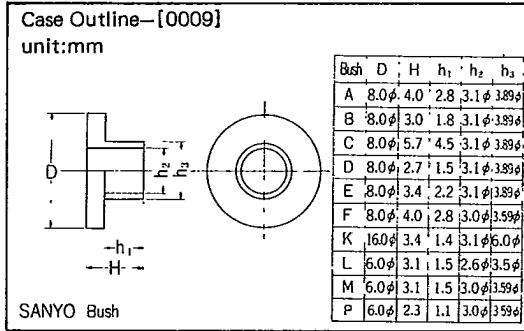
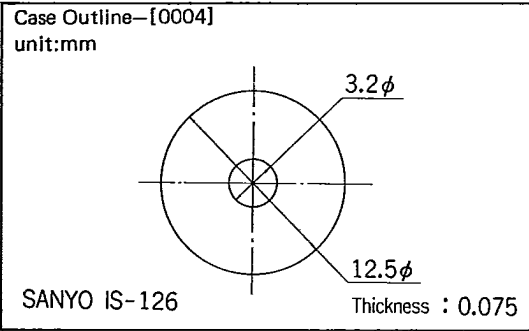
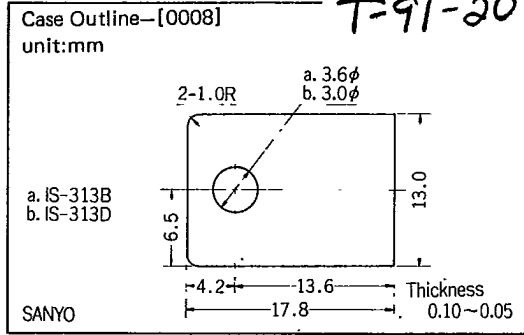
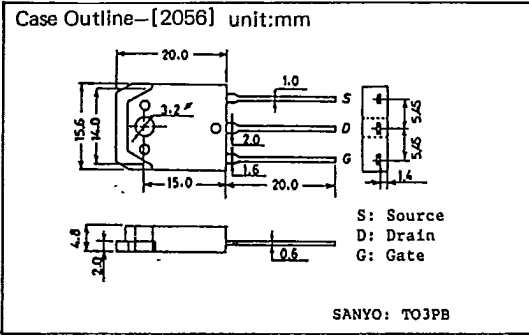

Case Outline-[0013]
unit:mm

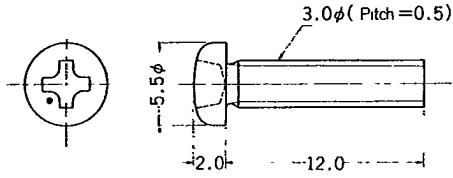

JIS No. B1111 M3×0.5

Case Outline-[0018]
unit:mm

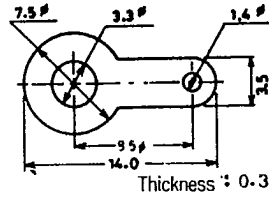

SANYO Lug 1.4

T=91-20

Case Outline-[0014]
unit:mm

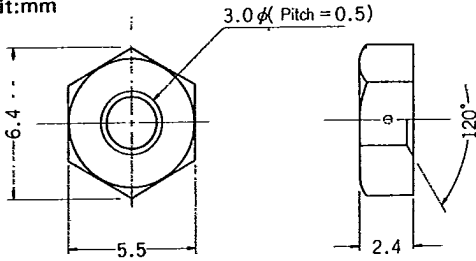

JIS No. B1181 M3×0.5

Case Outline-[0019]
unit:mm

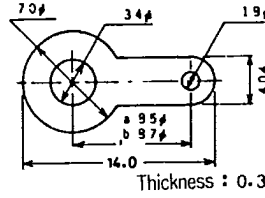

SANYO Lug 1.8φ

Case Outline-[0015]
unit:mm

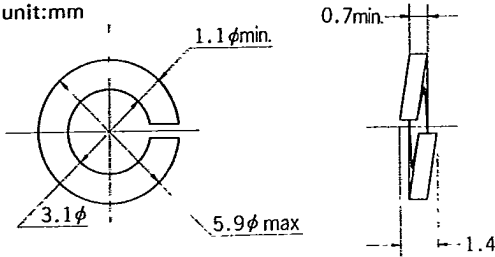

JIS No. B 1251 Spring washer (M3)

Case Outline-[0020]
unit:mm

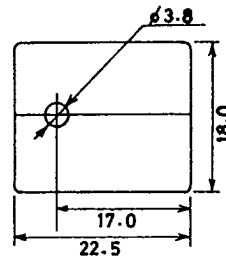

SANYO IS-3MP Mica

Case Outline-[0016]
unit:mm

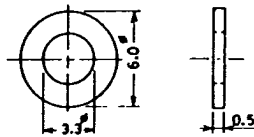

JIS No. B1252 Flat washer

Case Outline-[0021]
unit:mm

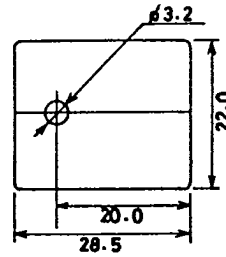

SANYO IS-MPC Mica

Case Outline-[0017]
unit:mm

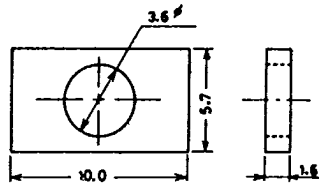

JIS No. G3141 Rectangular washer

Case Outline-[0022]
unit:mm

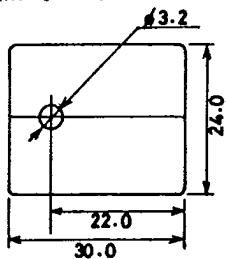

SANYO IS-3PBL Mica