

FEATURES

- Fully compliant with SCSI SPI-2, SPI-3, SPI-4, Ultra160, and Ultra320
- Provides multimode low-voltage differential/single-ended (LVD/SE) termination for nine signal-line pairs
- Auto-selection of LVD or SE termination
- 5% tolerance on SE and LVD termination resistance
- Low power-down capacitance of 3pF
- Onboard thermal-shutdown circuitry
- SCSI-bus hot-plug compatible
- Fully supports actively negated SE SCSI signals

PIN ASSIGNMENT

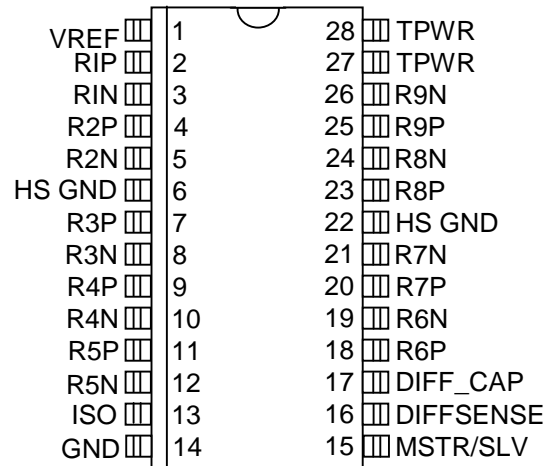

DS2119ME 28-Pin TSSOP

DESCRIPTION

The DS2119M Ultra3 LVD/SE SCSI Terminator is both a low-voltage differential (LVD) and single-ended (SE) terminator. The multimode operation enables the designer to implement LVD in current products while allowing the end-user SE-backward compatibility with legacy devices. If the device is connected in an LVD-only bus, the DS2119M will use LVD termination. If any SE devices are connected to the bus, the DS2119M will use SE termination. This is accomplished automatically inside the part by sensing the voltage on the SCSI bus DIFFSENS line.

For the LVD termination, the DS2119M integrates two current sources with nine precision resistor strings. For the SE termination, one regulator and nine precision 110Ω resistors are used. Three DS2119M terminators are needed for a wide SCSI bus.

REFERENCE DOCUMENTS

- | | | |
|---|-----------------------------------|-----------------------|
| Small Computer Systems Interface (SCSI-3) | SCSI Parallel Interface (SPI) | Project: 0855-M, 1995 |
| Small Computer Systems Interface (SCSI-3) | SCSI Parallel Interface 2 (SPI-2) | Project: 1142-M, 1998 |
| Small Computer Systems Interface (SCSI-3) | SCSI Parallel Interface 3 (SPI-3) | Project: 1302-D, 1999 |
| Small Computer Systems Interface (SCSI-3) | SCSI Parallel Interface 4 (SPI-4) | Project: 1365-D, 200x |

Available From:

American National Standards Institute (ANSI) Phone: (212) 642-4900

Global Engineering Documents 15 Inverness Way East, Englewood, CO 80112 Phone: (800) 854-7179

FUNCTIONAL DESCRIPTION

The DS2119 combines LVD and SE termination with DIFFSENS sourcing and detection.

A bandgap reference is fed into two amplifiers, which creates a 1.25V reference voltage and a 2.85V reference voltage. The control logic determines which of these references will be applied to the termination resistors. If the SCSI bus is in LVD mode, then the 1.25V reference will be used. If the SCSI bus is in SE mode, then the 2.85V reference will be used. That same control logic will switch in/out parallel resistors to change the total termination resistance accordingly. Finally, in SE mode, the Rp pins will be switched to ground.

The DIFFSENSE circuitry decodes trinary logic. There will be one of three voltages on the SCSI control line called DIFFSENS. Two comparators and a NAND gate determine if the voltage is below 0.6V, above 2.15V, or in between. That indicates the mode of the bus to be SE, HVD, or LVD, respectively.

The DS2119M's DIFF_CAP pin monitors the DIFFSENS line to determine the proper operating mode of the device. The DIFFSENSE pin can also drive the SCSI DIFFSENS line (when MSTR/SLV = 1) to determine the SCSI bus-operating mode. The DS2119M switches to the termination mode that is appropriate for the bus based on the value of the DIFFSENS voltage. These modes are:

- **LVD Mode:** LVD termination is provided by a precision laser-trimmed resistor string with two current sources. This configuration yields a 105Ω differential and 150Ω common-mode impedance. A fail-safe bias of 112mV is maintained when no drivers are connected to the SCSI bus.
- **SE Mode:** When the external driver for a given signal line turns off, the active terminator will pull that signal line to 2.85V (quiescent state). When used with an active negation driver, the power amp can sink 22mA per line and the reference voltage will move less than 100mV. The terminating resistors maintain their 110Ω value.
- **HVD Isolation Mode:** The DS2119M identifies that there is an HVD (high-voltage differential) device on the SCSI bus and isolates the termination pins from the bus.

When ISO = 1, the termination pins are isolated from the SCSI bus, V_{REF} remains active. During thermal shutdown, the termination pins are isolated from the SCSI bus and V_{REF} becomes high impedance. The DIFFSENSE driver is shut down during either of these two events.

To ensure proper operation, the TPWR pin should be connected to the SCSI bus TERMPWR line. As with all analog circuitry, the TERMPWR and V_{DD} lines should be bypassed locally. A 2.2μF capacitor and a 0.01μF high-frequency capacitor are recommended between TPWR and ground and placed as close as possible to the DS2119M. The DS2119M should be placed as close as possible to the SCSI connector to minimize signal and power-trace length, thereby resulting in less input capacitance and reflections, which can degrade the bus signals.

To maintain the specified regulation, a 4.7 μ F capacitor is required between the V_{REF} pin (VREF) and ground of each DS2119M. A high frequency cap (0.1 μ F ceramic recommended) can also be placed on the V_{REF} pin in applications that use fast rise/fall time drivers. A typical SCSI bus configuration is shown in Figure 2.

- **DIFFSENS Noise Filtering:** The DS2119M incorporates a digital filter to remove high-frequency transients on the DIFFSENS control line, thereby eliminating erroneous switching between modes. This filter eliminates the need for the external capacitor and resistor, which heretofore performed this function.

NOTES:

- 1) DIFFSENS. Refers to the SCSI bus signal.
- 2) DIFFSENSE. Refers to the Dallas Semiconductor pin name and internal circuitry relating the DIFFSENS driver.

Figure 1. DS2119M BLOCK DIAGRAM

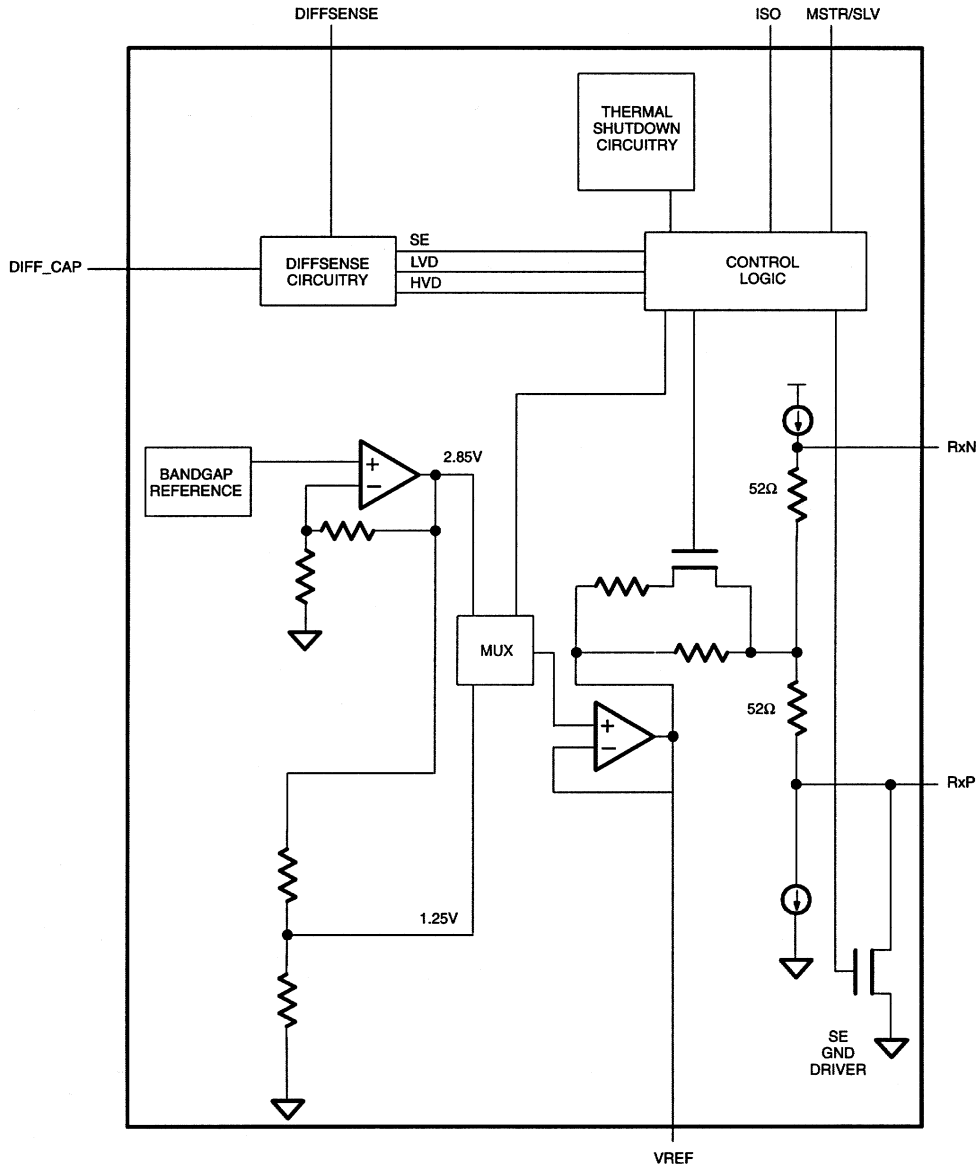

Table 1. PIN DESCRIPTION

PIN	SYMBOL	DESCRIPTION
1	VREF	Reference Voltage. 2.85V reference in SE mode and 1.25V reference in LVD mode; must be decoupled with a 4.7 μ F cap.
2–5, 7–12, 18–21, 23–26	RxP, RxN	Signal Termination. Connect to SCSI bus signal lines.
6, 22	HS GND	Heat Sink Ground. Internally connected to the mounting pad. Should be grounded.
13	ISO	Isolation. When pulled high, the DS2119M isolates its bus pins (RxP, RxN) from the SCSI bus.
14	GND	Ground. Signal ground; 0V.
15	MSTR/SLV	Master/Slave. Mode-select for the noncontrolling terminator. When pulled high, MSTR enables the DIFFSENSE driver.
16	DIFFSENSE	DIFFSENSE. Output to drive the SCSI bus DIFFSENS line.
17	DIFF_CAP	DIFFSENSE CAPACITOR. Connect a 0.1 μ F capacitor for DIFFSENSE filter. Input to detect the type of device (differential or single-ended) on the SCSI bus.
27, 28	TPWR	Termination Power. Connect to the SCSI TERMPWR line and decouple with a 2.2 μ F capacitor.

RECOMMENDED OPERATING CONDITIONS

PARAMETER	SYMBOL	MIN	TYP	MAX	UNITS	NOTES
Termpower Voltage						
SE Mode	$V_{TPWR(SE)}$	4.0		5.5	V	
LVD Mode	$V_{TPWR(LVD)}$	2.7		5.5	V	
Logic 0	V_{IL}	-0.3		+0.8	V	
Logic 1	V_{IH}	2.0		$V_{TPWR} + 0.3$	V	
Operating Temperature	V_{AMB}	0		70	°C	

SINGLE-ENDED CHARACTERISTICS

PARAMETER	SYMBOL	MIN	TYP	MAX	UNITS	NOTES
SE Termination Resistance	R_{SE}	104.5	110	115.5	Ω	1
SE Voltage Reference	V_{REF}	2.7	2.85	3.0	V	
SE Output Current	I_{OSE}			25.4	mA	2
Output Capacitance	C_{OUT}			3	pF	3

LOW-VOLTAGE DIFFERENTIAL CHARACTERISTICS

PARAMETER	SYMBOL	MIN	TYP	MAX	UNITS	NOTES
Differential Mode Termination Resistance	R_{DM}	100		110	Ω	
Common Mode Termination Resistance	R_{CM}	110		190	Ω	
Differential Mode Bias	V_{DM}	100		125	mV	4
Common Mode Bias	V_{CM}	1.125		1.375	V	

DC CHARACTERISTICS

PARAMETER	SYMBOL	MIN	TYP	MAX	UNITS	NOTES
Termpower Current	I_{TPMR}		12		mA	4
Input Leakage High	I_{IH}	-1.0			μ A	
Input Leakage Low	I_{IL}			1.0	μ A	
Output Current High	I_{OH}	-1.0			mA	5, 7
Output Current Low	I_{OL}	4.0			mA	6, 7
DIFFSENS SE Operating Range	V_{SEOR}	-0.3		0.5	V	
DIFFSENS LVD Operating Range	V_{LVDOR}	0.7		1.9	V	
DIFFSENS HVD Operating Range	V_{HVDOR}	2.4		$V_{TPWR} + 0.3$	V	
DIFFSENSE Driver Output Voltage	V_{DSO}	1.2		1.4	V	8, 9
DIFFSENSE Driver Source Current	I_{DSH}	5		15	mA	8, 10, 12
DIFFSENSE Driver Sink Current	I_{DSL}	20		200	μ A	8, 11
Thermal Shutdown			150		$^{\circ}$ C	3

REGULATOR CHARACTERISTICS

(0°C to +70°C)

PARAMETER	SYMBOL	MIN	TYP	MAX	UNITS	NOTES
Line Regulation	L_{REG}		1.0	2.5	%	
Load Regulation	L_{OREG}		1.3	3.5	%	
Current Limit	I_{LIM}		550		mA	
Sink Current	I_{SINK}	200			mA	

NOTES:

- 1) $V_{LINE} = 0V$ to $3V$.
- 2) $V_{LINE} = 0.2V$.
- 3) Guaranteed by design.
- 4) All lines open.
- 5) $V_{OUT} = 2.4V$.
- 6) $V_{OUT} = 0.4V$.
- 7) SE/LVD/HVD pins only.
- 8) $MSTR/SLV = 1$.
- 9) $I_{DS} = 0mA$ to $5mA$.
- 10) $V_{DSO} = 0V$.
- 11) $V_{DSO} = 2.75V$.
- 12) $TPWR = 5.5V$.

DS2119M 28-PIN SSOP PACKAGE

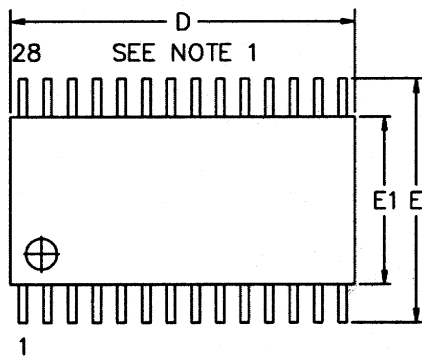

NOTES:

- 1) DIMENSION "D" DOES NOT INCLUDE MOLD MISMATCH, FLASH, OR PROTRUSIONS. MOLD MISMATCH, FLASH, AND PROTRUSIONS SHALL NOT EXCEED 0.15 PER SIDE.
- 2) DIMENSION "B" DOES NOT INCLUDE DAMBAR PROTRUSION. DAMBAR PROTRUSION SHALL NOT BE LOCATED ON THE LOWER RADIUS OF THE FOOT.

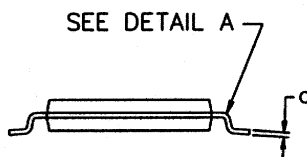
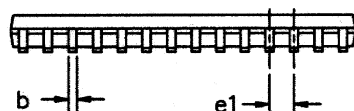

PKG	28-PIN	
DIM	MIN	MAX
A	-	1.10
A1	0.05	-
A2	0.75	1.05
c	0.09	0.20
L	0.50	0.75
e1	0.65 BSC	
b	0.18	0.30
D	9.60	9.80
E1	4.40 BSC	
E	6.20	6.60

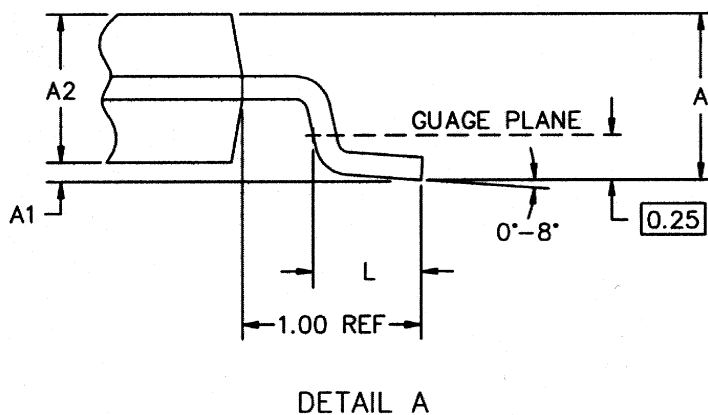

DETAIL A



LittleDiode supplies new, hard to find or obsolete electronic components and semiconductors all over the world.

With over two million different components listed you are sure to find the part you need.

Feel free to visit us today at our online store:

LittleDiode.com

Looking forward to providing you with the best possible service.