

FEATURES

- Fully compliant with SCSI-1, Fast SCSI and Ultra SCSI
- Compatible with Plug and Play SCSI Profile
- Functional drop in replacement for the DS2109
- Complementary part to DS21T07 for wide SCSI
- Provides active termination for 18 signal lines
- 2% tolerance on termination resistors and voltage regulator
- Bus termination sensing
- Low power-down capacitance of 3 pF
- Onboard thermal shutdown circuitry

PIN ASSIGNMENT

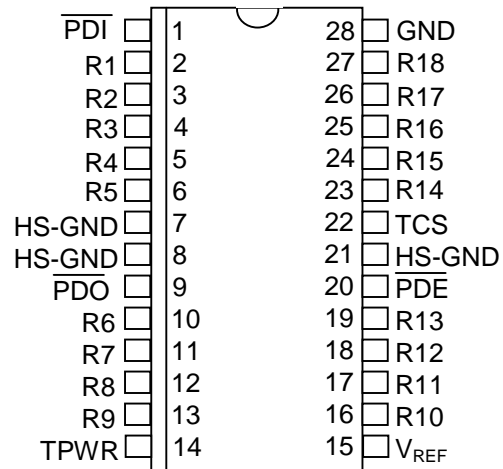

DS21T09S 28-Pin SOIC (300-mil)

DESCRIPTION

The DS21T09 is intended for one-chip Plug and Play (PnP) SCSI termination. Plug and Play SCSI requires the exit-point terminator on computer motherboards or host bus adapters to automatically switch off if an external device is connected to the system. The DS21T09 satisfies this requirement by offering the engineer a choice of onboard current sensing circuitry or onboard ground detect circuitry. If an external device is connected, the DS21T09 will automatically be isolated from the SCSI bus thereby maintaining proper system termination.

The DS21T09 integrates a low drop-out regulator, 18 precisely switched 110Ω termination resistors, and bus termination sensors into a 28-pin, 300-mil SOIC package. Active termination provides: greater immunity to voltage drops on the TERMPWR (TERMination PoWeR) line, enhanced high-level noise immunity, intrinsic TERMPWR decoupling, and very low quiescent current consumption. The DS21T09 contains an output port that can control the power-down pin of additional terminators (DS21T07) for Wide SCSI applications.

REFERENCE DOCUMENTS

SCSI-2 (X3.131-1994)
 SCSI-3 Parallel Interface (X3T10/855D)
 Available from: Global Engineering Documents
 15 Inverness Way East
 Englewood, CO 80112-5704
 Phone: (800) 854-7179, (303) 792-2181
 Fax: (303) 792-2192

PnP SCSI Specification
 PnP ISA Specification
 PnP BIOS Specification
 PnP Option ROM Specification
 Available from: Plug and Play forum on
 CompuServe (Go plugplay).

FUNCTIONAL DESCRIPTION

The DS21T09 is designed to be a single chip termination subsystem for use in PnP SCSI systems, Figure 1. When embedded on a host bus adapter or motherboard, the DS21T09 can automatically sense the termination status of the SCSI bus and attach or isolate its resistors as needed to maintain proper bus termination. External and internal active termination can be provided by the DS21T07.

DS21T09 APPLICATION ENVIRONMENT Figure 1

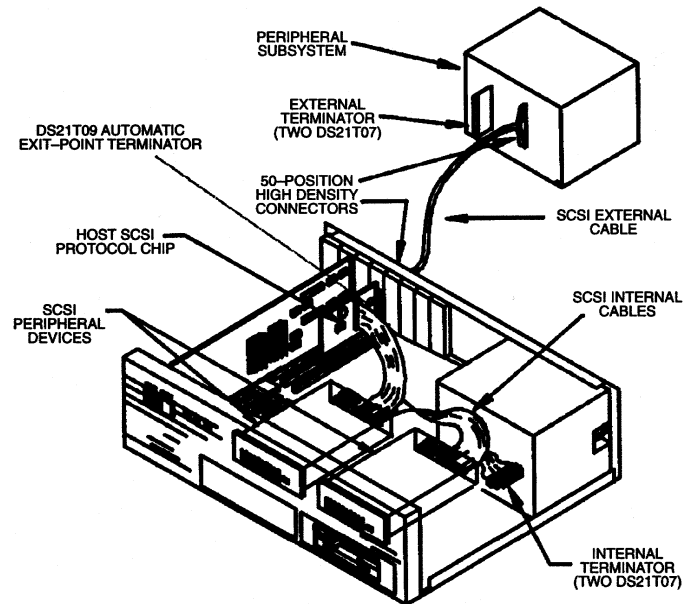

The DS21T09 consists of three major functional blocks, Figure 2:

- Voltage reference, terminating resistors, and isolation switches
- Bus current sensing circuitry
- Bus ground sensing circuitry

When the Bus Ground Sensing Circuitry or Bus Current Sensing Circuitry determines that the SCSI bus is properly terminated without the DS21T09, the power-down buffer isolates the resistors from the SCSI bus and disables the power amp, thereby placing the DS21T09 in a low power mode (the bus sensing circuitry always stays active). The $\overline{\text{PDO}}$ (Power-Down Output) pin can be connected to the pin of a DS21T07 SCSI terminator for Wide SCSI configurations, Figure 8.

DS21T09 BLOCK DIAGRAM Figure 2

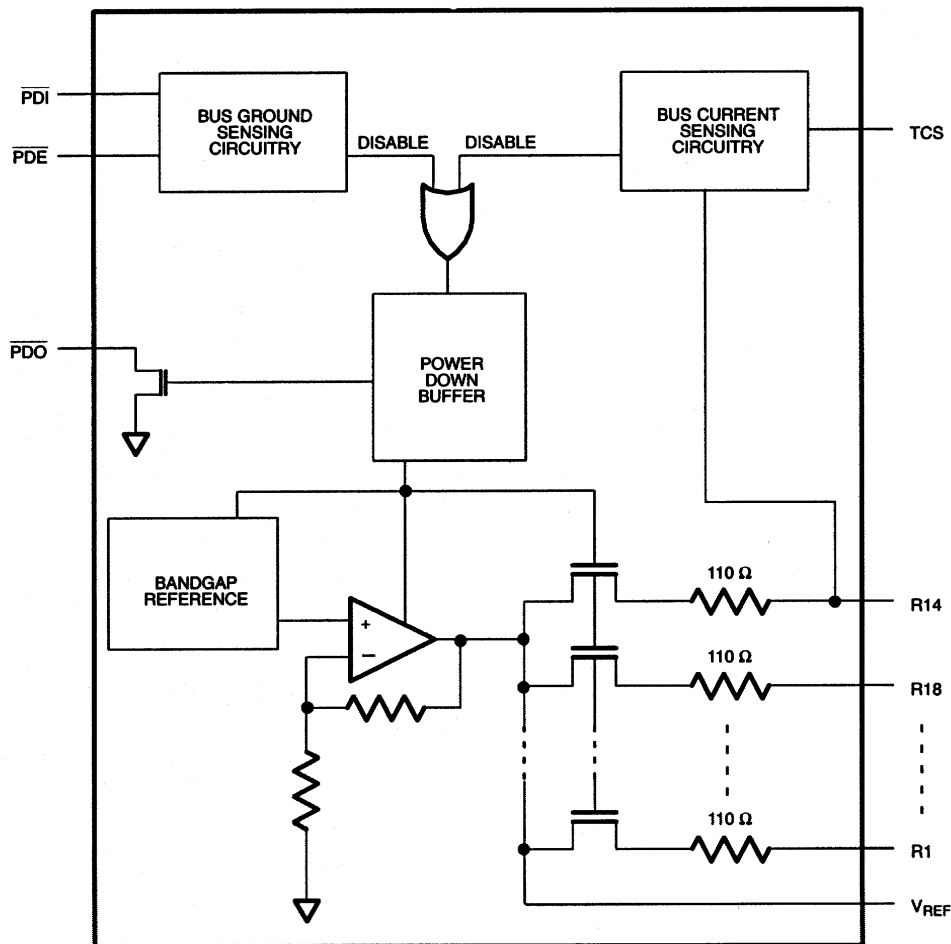

DETAILED PIN DESCRIPTION Table 1

PIN	SYMBOL	FCN	DESCRIPTION
1	$\overline{\text{PDI}}$	I	Power-Down Internal. For Bus Ground Sensing Circuit, connect to pin 22 of internal SCSI connector; see Figure 4.
2-6, 10-13, 16-19, 24-27	R1...R13 R15...R18	T	Signal Termination. 110 Ω termination. Connect to SCSI bus signal lines. For Bus Current Sensing Circuit connect to data, parity, and control lines, except SCSI-RST line; see Figure 6.
7, 8, 21	HS-GND	P	Heat Sink Ground. Internally connected to the mounting pad. Should be either grounded or electronically isolated from other circuitry.
9	$\overline{\text{PDO}}$	O	Power-Down Output. Connect to DS21T07 for Wide SCSI applications; see Figure 8.
14	TPWR	P	Termination Power. Connect to the SCSI TERMPWR line. Bypass with a 2.2 μF capacitor; see Figures 4 and 6.
15	V_{REF}	O	Reference Voltage. 2.85-volt reference; must be decoupled with a 4.7 μF capacitor; see Figures 4 and 6.
20	$\overline{\text{PDE}}$	I	Power-Down External. For Bus Ground Sensing Circuit, connect to pin 36 of external SCSI connector; see Figure 4.
22	TCS	I	Termination Current Sense. Used to sense current on the SCSI bus. For Bus Current Sensing Circuit, connect to SCSI signal line $-\text{RST}$; see Figure 6.
23	R14	T	Signal Termination. 110 Ω termination. Connect to SCSI bus signal lines. For Bus Current Sensing Circuit connect to SCSI controller chip; see Figure 6.
28	GND	P	Ground. Signal ground; 0.0 volts.

ACTIVE TERMINATION

The voltage regulator circuitry (bandgap reference and class AB power amplifier) produces a precise, laser-trimmed 2.85-volt level and is capable of sourcing 25 mA into each of the terminating resistors when the signal line is low (active). When the external driver for a given signal line turns off, the active terminator will pull that signal line to 2.85 volts (quiescent state). When used with an active negation driver, the power amp can sink 22 mA per line while keeping the voltage reference in regulation; the terminating resistors maintain their 110 Ω value over the entire voltage range and V_{ref} will move less than 60 mv. To maintain the specified regulation, a 4.7 μF capacitor is required between the V_{REF} pin and ground. A high frequency capacitor (0.1 μF ceramic recommended) can also be placed on the V_{ref} pin in applications that use fast rise/fall time drivers. The power down capacitance on terminating resistors R1-R13 and R15-R18 is <3 pF; R14 is slightly higher due to the bus current sensing circuitry.

The DS21T09 can be removed from the SCSI bus by using either of two automatic methods: Bus Ground Sensing or Bus Current Sensing.

As with all analog circuitry, the TERMPWR lines should be bypassed locally. A 2.2 μF capacitor is recommended between TPWR and ground. It should be placed as close as possible to the DS21T09. The DS21T09 should be placed as close as possible to the connector to minimize signal and power trace length, thereby resulting in less input capacitance and reflections which can degrade the bus signals.

BUS GROUND SENSING

If internal and external SCSI devices are connected to the SCSI bus, the DS21T09 will disconnect from the SCSI bus according to the circuit in Figure 3. To utilize this automatic disconnect method of bus sensing, configure the DS21T09 as shown in Figure 4. The $\overline{\text{PDI}}$ (Power Down Internal) pin should be connected to pin 22 of the internal SCSI connector, and the $\overline{\text{PDE}}$ (Power Down External) connected to pin 36 of the external SCSI connector.

BUS GROUND SENSING CIRCUIT Figure 3

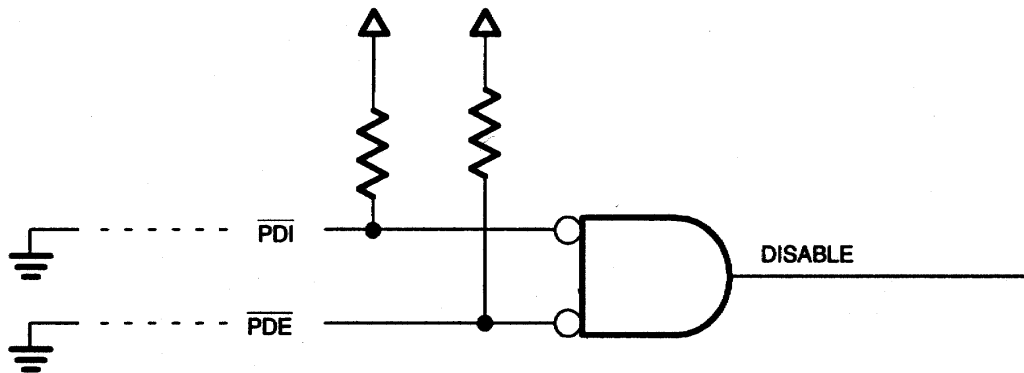

BUS GROUND DETECT CONFIGURATION Figure 4

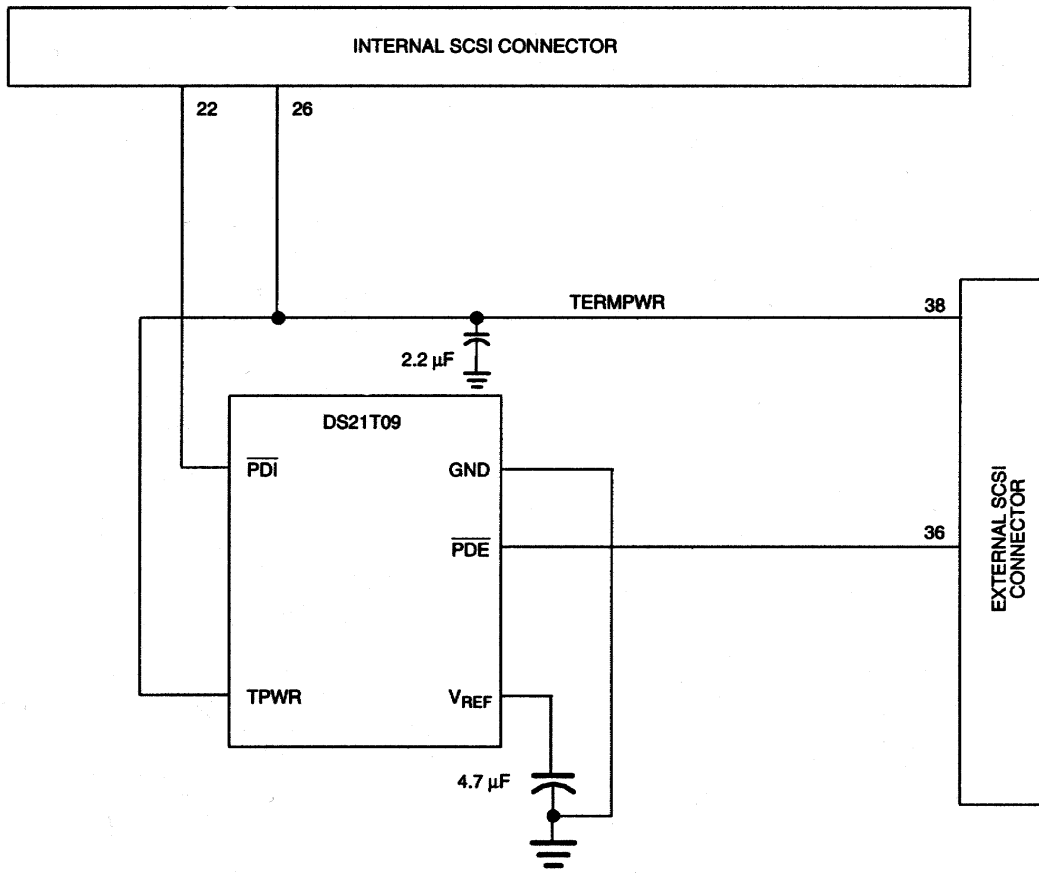

BUS CURRENT SENSING

The DS21T09 has the capability to use current sensing to determine if the SCSI bus is over- or under-terminated. A 1Ω resistor in series with the SCSI bus (preferable the RST line) is used to monitor the bus current when that line pulls low (Active or “asserted” state). The resistor is between pad R14 and TCS on the die. Based on the current measured, the DS21T09 will disconnect or connect from the SCSI bus. The configuration for this automatic isolation technique is shown in Figure 6.

Figure 5 shows a simplified diagram of the sensing circuit. The voltage across the 1Ω sense resistor is differentially amplified and converted into a single-ended voltage with respect to ground. This is fed into a bank of comparators and measured against a reference voltage. The circuit takes a measurement each time TCS is driven below a 0.8 volts threshold and the outputs are latched on the rising edge of TCS. If I_{BUS} is greater than 32 mA, the DS21T09 will be isolated from the SCSI bus. It is recommended that the signal on TCS be asserted for at least 25 μsec to allow the signal (and comparator outputs) to settle into a known state. A timing diagram of the sensing and latching operation is shown in Figure 7.

It is preferred that the -RST line be used for monitoring the bus termination status because -RST is only asserted during power up or during a major change in bus configuration. Note that R14 will have a higher input capacitance than the other lines because of the additional circuitry required for bus sensing.

The DS21T09 will be isolated from the SCSI bus as shown in Table 2.

BUS CURRENT SENSING CIRCUITRY Figure 5

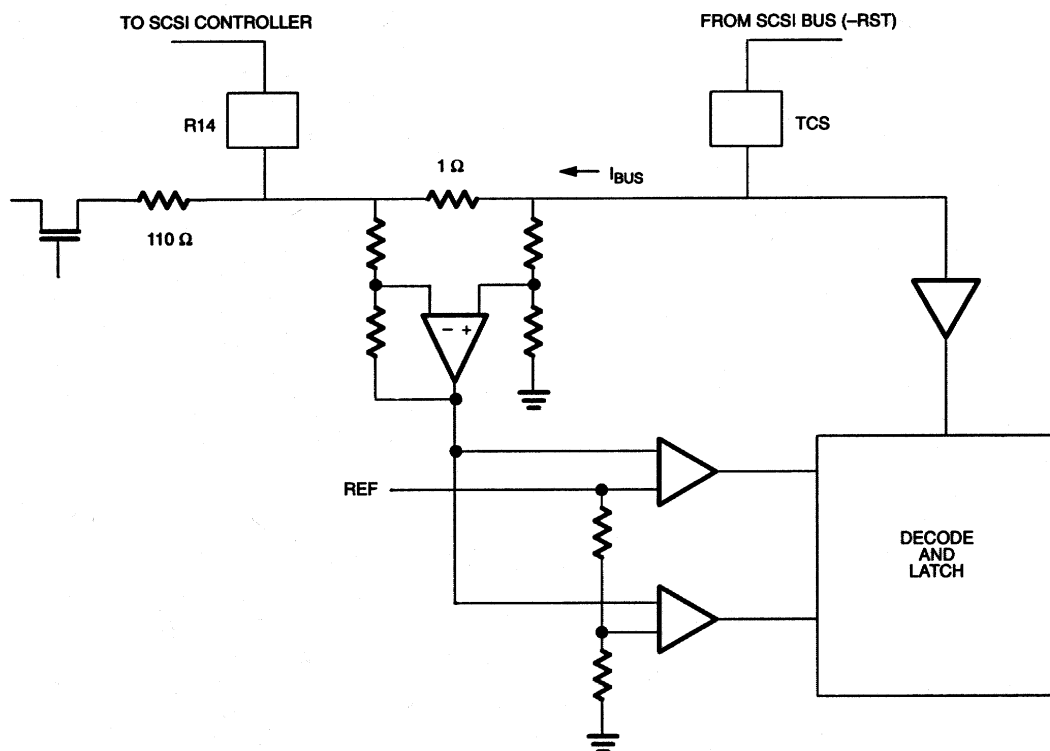

BUS CURRENT SENSE CONFIGURATION Figure 6

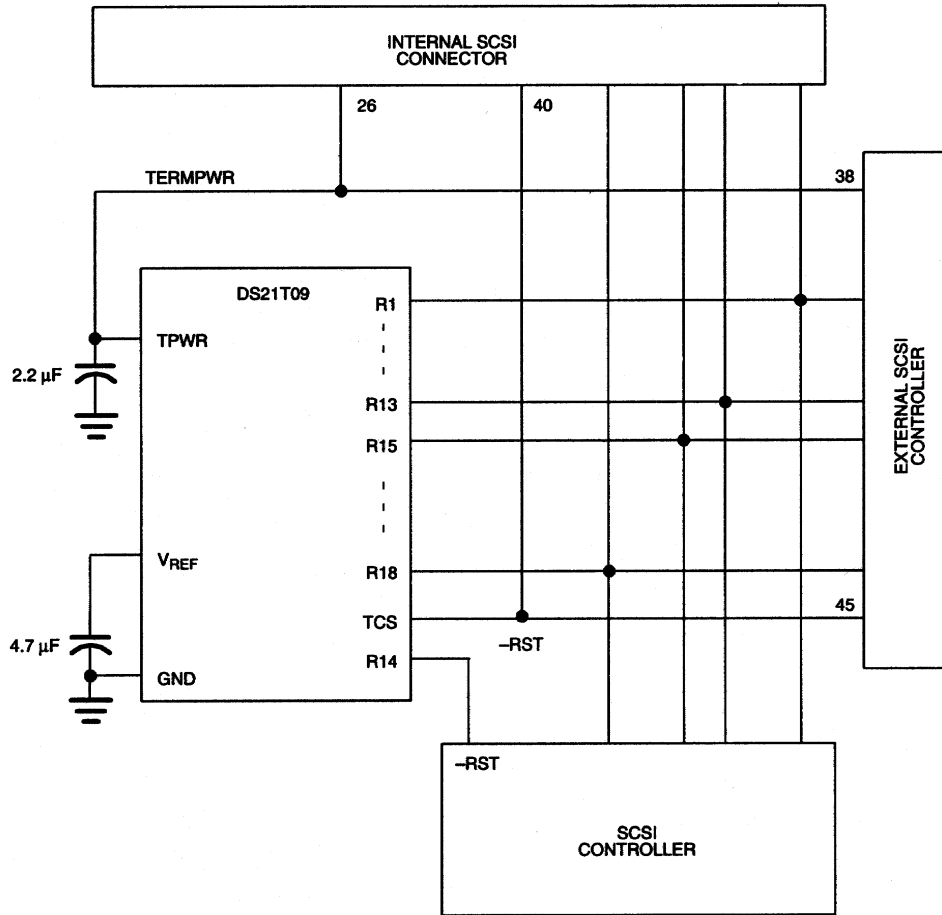

BUS CURRENT SENSE TIMING DIAGRAM Figure 7

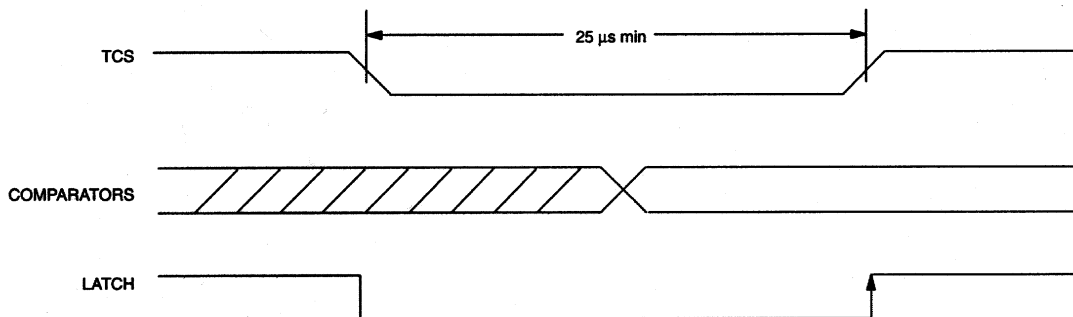

DISCONNECT MODES Table 2

$\overline{\text{PDI}}$	$\overline{\text{PDE}}$	$I_{\text{BUS}} > 32 \text{ mA?}$	DS21T09 ISOLATED FROM SCSI BUS?
0	0	No	Isolated
0	1	No	Connected
1	0	No	Connected
1	1	No	Connected
0	0	Yes	Isolated
0	1	Yes	Isolated
1	0	Yes	Isolated
1	1	Yes	Isolated

NOTE: "1" denotes pin left open circuited.

WIDE SCSI CONFIGURATION Figure 8

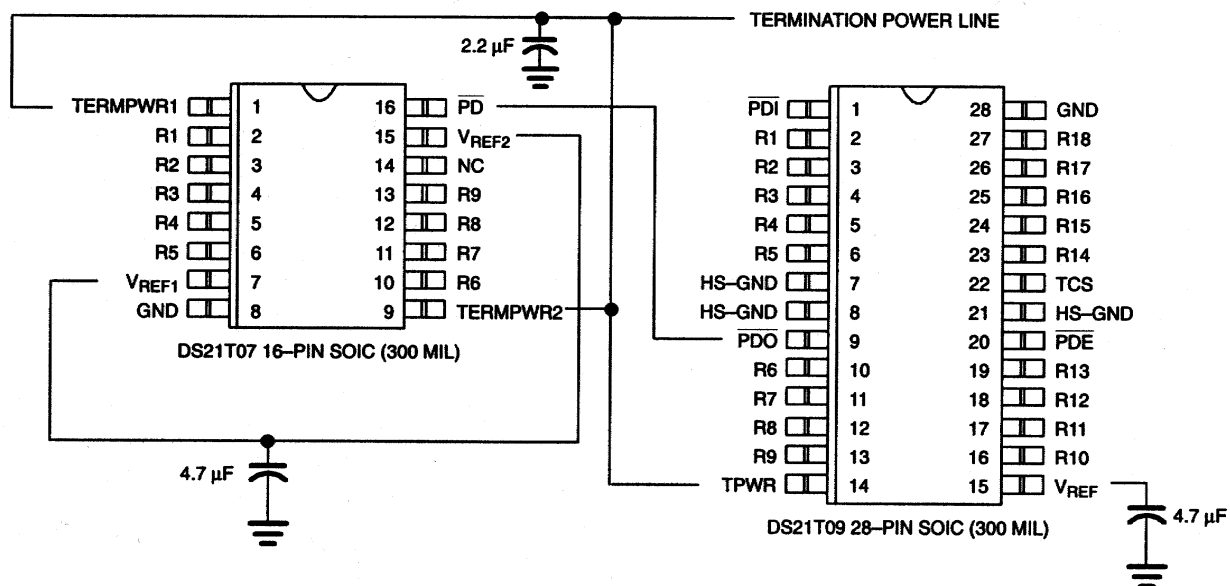

ABSOLUTE MAXIMUM RATINGS*

Voltage on Any Pin Relative to Ground	-1.0V to +7.0V
Operating Temperature	0°C to 70°C
Storage Temperature	-55°C to +125°C
Soldering Temperature	260°C for 10 seconds

* This is a stress rating only and functional operation of the device at these or any other conditions above those indicated in the operation sections of this specification is not implied. Exposure to absolute maximum rating conditions for extended periods of time may affect reliability.

The Dallas Semiconductor DS21T09 is built to the highest quality standards and manufactured for long term reliability. All Dallas Semiconductor devices are made using the same quality materials and manufacturing methods. However, the DS21T09 is not exposed to environmental stresses, such as burn-in, that some industrial applications require. For specific reliability information on this product, please contact the factory in Dallas at (972) 371-4448.

RECOMMENDED OPERATING CONDITIONS (0°C to 70°C)

PARAMETER	SYMBOL	MIN	TYP	MAX	UNITS	NOTES
TERMPWR Voltage	V_{TP}	4.00		5.25	V	
Logic 1	V_{IH}	2.0		$V_{TP} + 0.3$	V	1
Logic 0	V_{IL}	-0.3		+0.8	V	1

DC CHARACTERISTICS (0°C to 70°C)

PARAMETER	SYMBOL	MIN	TYP	MAX	UNITS	NOTES
TERMPWR Current	I_{TP}			500	mA	2, 4
	I_{TP}		10	14	mA	2, 5
Power-Down Current	I_{PD}		1	2	mA	2, 3, 6
Termination Resistance	R_{TERM}	108	110	112	Ω	2, 3
Die Thermal Shutdown	TS_D		150		°C	2
Power-Down Termination Capacitance	C_{PD}		8		pF	2, 3, 6, 7
	C_{14}				pF	2, 3, 6, 7, 8
Input Leakage High	I_{IH}	-1.0			μ A	2, 12
Input Leakage Low	I_{IL}			1.0	μ A	2, 9, 12
Output Current	I_O	4			mA	10
Bus Current Sense Trip Point	I_{BCST}		32		mA	11

REGULATOR CHARACTERISTICS (0°C to 70°C)

PARAMETER	SYMBOL	MIN	TYP	MAX	UNITS	NOTES
Output Voltage	V_{REF}	2.79	2.85	2.93	V	2, 3
Drop Out Voltage	V_{DROP}		0.75	1.0	V	4, 7
Line Regulation	LI_{REG}		1.0	2.0	%	2, 5
Load Regulation	LO_{REG}		1.3	3.0	%	2, 3
Current Limit	I_L		900		mA	2
Sink Current	I_{SINK}		400		mA	2

NOTES:

1. $\overline{\text{PDI}}$, $\overline{\text{PDE}}$, TCS
2. $4.00\text{V} < \text{TERMPWR} < 5.50\text{V}$.
3. $0.0\text{V} < \text{signal lines} < \text{TERMPWR}$.
4. All signal lines = 0.0V .
5. All signal lines open.
6. Power down enabled.
7. Guaranteed by design; not production tested.
8. C^{14} slightly higher capacitance due to sensing circuitry.
9. Excluding $\overline{\text{PDI}}$, $\overline{\text{PDE}}$ pins.
10. $\overline{\text{PDO}}$ output pin.
11. $I_{\text{BCST}} > 32 \text{ mA}$ – disable termination.
12. Excluding $\overline{\text{PDE}}$, $\overline{\text{PDI}}$, R14, and TCS pins.

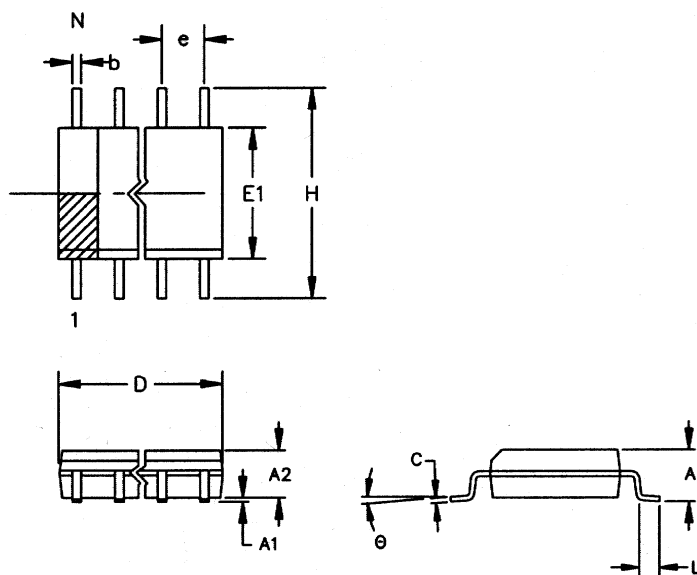
28-PIN SOIC (300-MIL)

The chamfer on the body is optional. If it is not present, a terminal 1 identifier must be positioned so that $\frac{1}{2}$ or more of its area is contained in the hatched zone.

PKG	28-PIN	
DIM	MIN	MAX
A IN.	0.094	0.105
MM	2.39	2.67
A1 IN.	0.004	0.012
MM	0.102	0.30
A2 IN.	0.089	0.095
MM	2.26	2.41
b IN.	0.013	0.020
MM	0.33	0.51
C IN.	0.009	0.013
MM	0.229	0.33
D IN.	0.698	0.712
MM	17.73	18.08
e IN.	0.050 BSC	
MM	1.27 BSC	
E1 IN.	0.290	0.300
MM	7.37	7.62
H IN.	0.398	0.416
MM	10.11	10.57
L IN.	0.016	0.040
MM	0.40	1.02
θ	0°	8°



LittleDiode supplies new, hard to find or obsolete electronic components and semiconductors all over the world.

With over two million different components listed you are sure to find the part you need.

Feel free to visit us today at our online store:

LittleDiode.com

Looking forward to providing you with the best possible service.