

DS3487

Quad TRI-STATE® Line Driver

General Description

National's quad RS-422 driver features four independent drivers which comply with EIA Standards for the electrical characteristics of balanced voltage digital interface circuits. The outputs are TRI-STATE structures which are forced to a high impedance state when the appropriate output control pin reaches a logic zero condition. All input pins are PNP buffered to minimize input loading for either logic one or logic zero inputs.

Features

- Four independent drivers
- TRI-STATE® outputs
- Fast propagation times (typ 10 ns)
- TTL compatible
- 5V supply
- Output rise and fall times less than 15 ns
- Pin compatible with DS8924 and MC3487

Block and Connection Diagrams

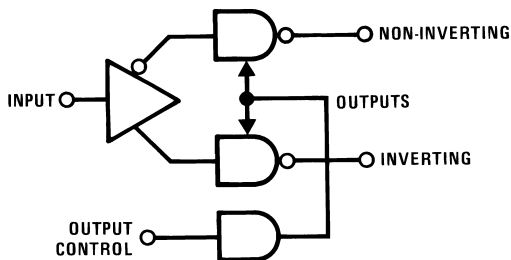

00578001

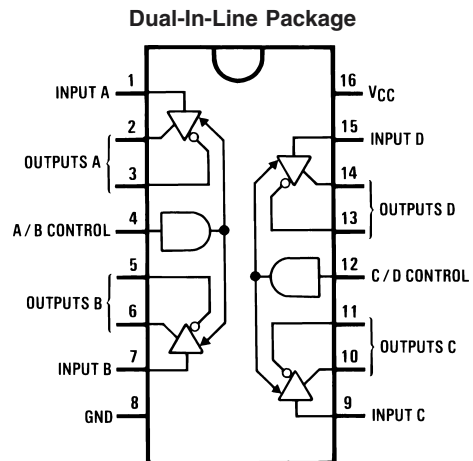

00578002

Top View
Order Number DS3487M or DS3487N
See NS Package Number M16A or N16E

Truth Table

Input	Control Input	Non-Inverting Output	Inverting Output
H	H	H	L
L	H	L	H
X	L	Z	Z

L = Low logic state
H = High logic state
X = Irrelevant
Z = TRI-STATE(high impedance)

Absolute Maximum Ratings (Note 2)

(Soldering, 4 seconds)

260 °C

If Military/Aerospace specified devices are required, please contact the National Semiconductor Sales Office/Distributors for availability and specifications.

Supply Voltage	8V
Input Voltage	5.5V
Storage Temperature	-65°C to +150°C
Maximum Power Dissipation (Note 1) at 25°C	
Molded DIP Package	1476 mW
SO Package	1051 mW
Lead Temperature	

Operating Conditions

	Min	Max	Units
Supply Voltage, V_{CC}			
DS3487	4.75	5.25	V
Temperature (T_A)			
DS3487	0	+70	°C

Note 1: Derate DIP molded package 11.9 mW/°C above 25°C. Derate SO package 8.41 mW/°C above 25°C.

Electrical Characteristics (Notes 3, 4, 5, 6)

Symbol	Parameter	Conditions	Min	Typ	Max	Units
V_{IL}	Input Low Voltage				0.8	V
V_{IH}	Input High Voltage		2.0			V
I_{IL}	Input Low Current	$V_{IL} = 0.5V$			-200	µA
I_{IH}	Input High Current		$V_{IH} = 2.7V$		50	µA
			$V_{IH} = 5.5V$		100	µA
V_{CL}	Input Clamp Voltage	$I_{CL} = -18\text{ mA}$			-1.5	V
V_{OL}	Output Low Voltage	$I_{OL} = 48\text{ mA}$			0.5	V
V_{OH}	Output High Voltage	$I_{OH} = -20\text{ mA}$	2.5			V
I_{OS}	Output Short-Circuit Current		-40		-140	mA
I_{OZ}	Output Leakage Current (TRI-STATE)		$V_O = 0.5V$		-100	µA
			$V_O = 5.5V$		100	µA
I_{OFF}	Output Leakage Current Power OFF	$V_{CC} = 0V$	$V_O = 6V$		100	µA
			$V_O = -0.25V$		-100	µA
$ V_{OS} - \overline{V}_{OS} $	Difference in Output Offset Voltage				0.4	V
V_T	Differential Output Voltage		2.0			V
$ V_{T1} - \overline{V}_{T1} $	Difference in Differential Output Voltage				0.4	V
I_{CC}	Power Supply Current		Active	50	80	mA
			TRI-STATE®	35	60	mA

Switching Characteristics $V_{CC} = 5V, T_A = 25^\circ C$

Symbol	Parameter	Conditions	Min	Typ	Max	Units
t_{PHL}	Input to Output			10	15	ns
t_{PLH}	Input to Output			10	15	ns
t_{THL}	Differential Fall Time			10	15	ns
t_{TLH}	Differential Rise Time			10	15	ns
t_{PHZ}	Enable to Output	$R_L = 200\Omega, C_L = 50\text{ pF}$		17	25	ns
t_{PLZ}	Enable to Output	$R_L = 200\Omega, C_L = 50\text{ pF}$		15	25	ns
t_{PZH}	Enable to Output	$R_L = \infty, C_L = 50\text{ pF}, S1\text{ Open}$		11	25	ns
t_{PZL}	Enable to Output	$R_L = 200\Omega, C_L = 50\text{ pF}, S2\text{ Open}$		15	25	ns

Note 2: "Absolute Maximum Ratings" are those values beyond which the safety of the device cannot be guaranteed. They are not meant to imply that the devices should be operated at these limits. The table of "Electrical Characteristics" provides conditions for actual device operation.

Note 3: Unless otherwise specified min/max limits apply across the 0°C to +70°C range for the DS3487. All typicals are given for $V_{CC} = 5V$ and $T_A = 25^\circ C$.

Note 4: All currents into device pins are positive, all currents out of device pins as negative. All voltages are referenced to ground unless otherwise specified.

Note 5: Only one output at a time should be shorted.

Note 6: Symbols and definitions correspond to EIA RS-422, where applicable.

AC Test Circuits and Switching Time Waveforms

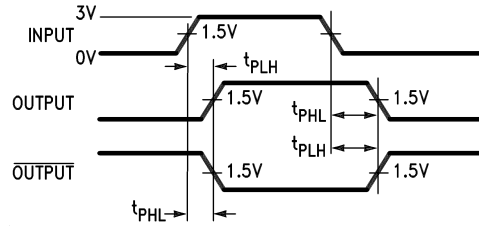
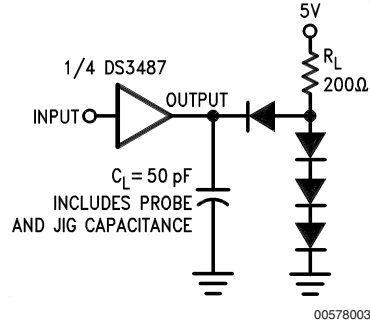

Input pulse: $f = \text{MHz}$, 50%; $t_r = t_f \leq 15 \text{ ns}$.

FIGURE 1. Propagation Delays

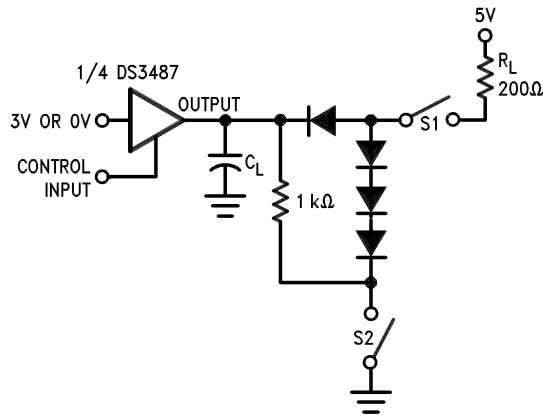

S1 and S2 closed except as noted.
 C_L includes probe and jig capacitance.

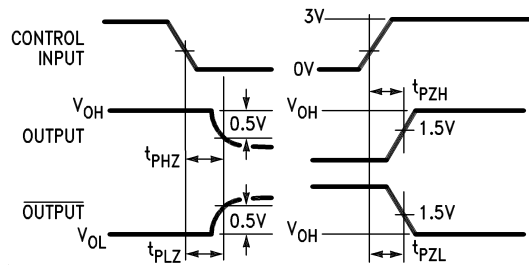

Input pulse: $f = \text{MHz}$, 50%; $t_r = t_f \leq 15 \text{ ns}$.
 S1 = open for t_{PZH}
 S2 = open for t_{PZL}

FIGURE 2. TRI-STATE Enable and Disable Delays

AC Test Circuits and Switching Time Waveforms (Continued)

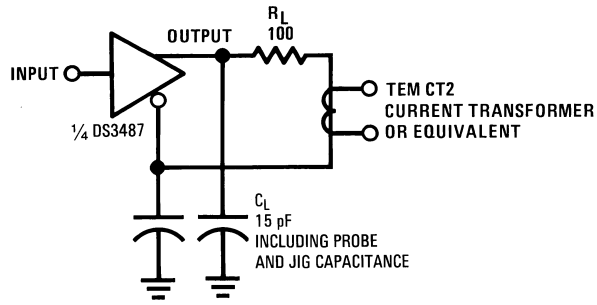

00578007

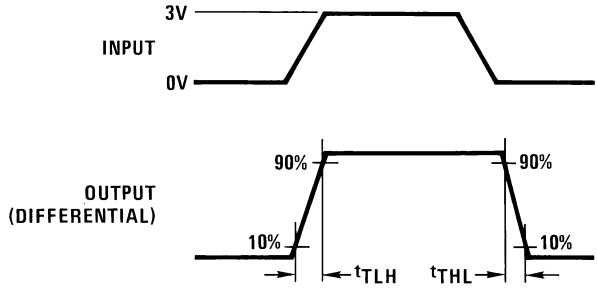

00578008

Input pulse: $f = \text{MHz}$, 50%; $t_r = t_f \leq 15 \text{ ns}$.

FIGURE 3. Differential Rise and Fall Times

Physical Dimensions inches (millimeters) unless otherwise noted

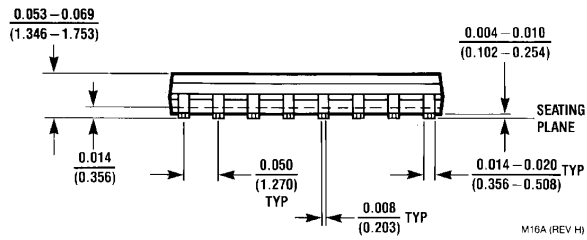
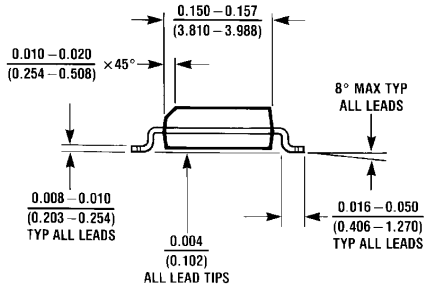
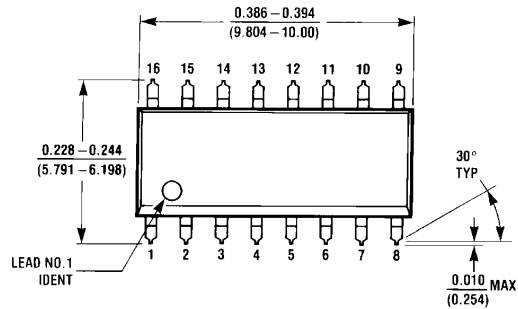

Small Outline Package (M)
Order Number DS3487M
NS Package Number M16A

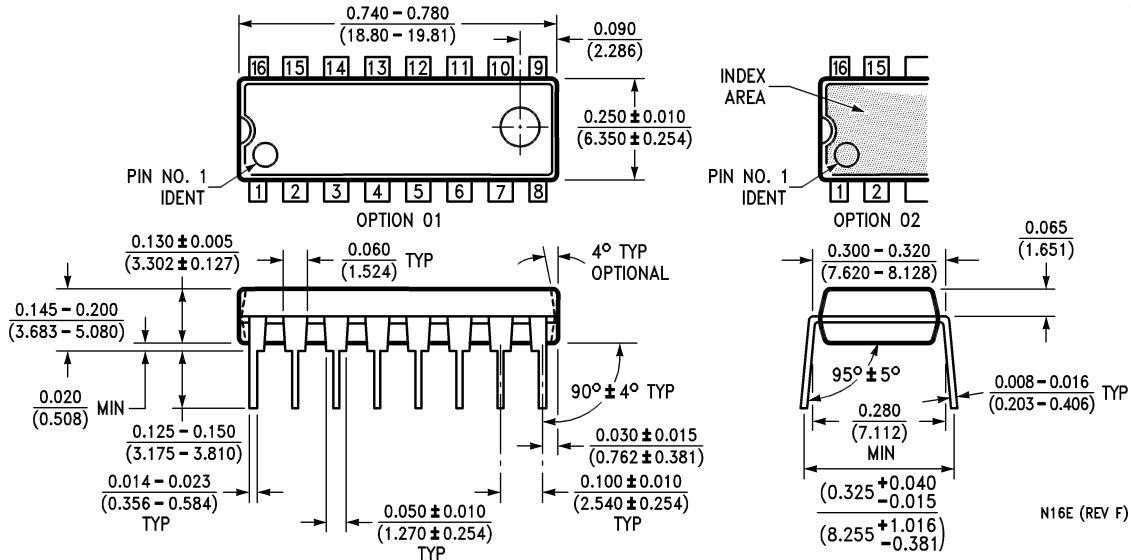

Molded Dual-In-Line Package (N)
Order Number DS3487N
NS Package Number N16E

Notes

LIFE SUPPORT POLICY

NATIONAL'S PRODUCTS ARE NOT AUTHORIZED FOR USE AS CRITICAL COMPONENTS IN LIFE SUPPORT DEVICES OR SYSTEMS WITHOUT THE EXPRESS WRITTEN APPROVAL OF THE PRESIDENT AND GENERAL COUNSEL OF NATIONAL SEMICONDUCTOR CORPORATION. As used herein:

1. Life support devices or systems are devices or systems which, (a) are intended for surgical implant into the body, or (b) support or sustain life, and whose failure to perform when properly used in accordance with instructions for use provided in the labeling, can be reasonably expected to result in a significant injury to the user.
2. A critical component is any component of a life support device or system whose failure to perform can be reasonably expected to cause the failure of the life support device or system, or to affect its safety or effectiveness.

BANNED SUBSTANCE COMPLIANCE

National Semiconductor certifies that the products and packing materials meet the provisions of the Customer Products Stewardship Specification (CSP-9-111C2) and the Banned Substances and Materials of Interest Specification (CSP-9-111S2) and contain no "Banned Substances" as defined in CSP-9-111S2.



National Semiconductor
Americas Customer
Support Center
 Email: new.feedback@nsc.com
 Tel: 1-800-272-9959

www.national.com

National Semiconductor
Europe Customer Support Center
 Fax: +49 (0) 180-530 85 86
 Email: europa.support@nsc.com
 Deutsch Tel: +49 (0) 69 9508 6208
 English Tel: +44 (0) 870 24 0 2171
 Français Tel: +33 (0) 1 41 91 8790

National Semiconductor
Asia Pacific Customer
Support Center
 Email: ap.support@nsc.com

National Semiconductor
Japan Customer Support Center
 Fax: 81-3-5639-7507
 Email: jpn.feedback@nsc.com
 Tel: 81-3-5639-7560

National Semiconductor was acquired by Texas Instruments.

http://www.ti.com/corp/docs/investor_relations/pr_09_23_2011_national_semiconductor.html

This file is the datasheet for the following electronic components:

DS3487M - <http://www.ti.com/product/ds3487m?HQS=TI-null-null-dscatalog-df-pf-null-wwe>

DS3487MX - <http://www.ti.com/product/ds3487mx?HQS=TI-null-null-dscatalog-df-pf-null-wwe>

DS3487N - <http://www.ti.com/product/ds3487n?HQS=TI-null-null-dscatalog-df-pf-null-wwe>



LittleDiode supplies new, hard to find or obsolete electronic components and semiconductors all over the world.

With over two million different components listed you are sure to find the part you need.

Feel free to visit us today at our online store:

LittleDiode.com

Looking forward to providing you with the best possible service.