

## DS1651/DS3651

### Quad High Speed MOS Sense Amplifiers

#### General Description

The DS1651/DS3651 is TTL compatible high speed circuits intended for sensing in a broad range of MOS memory system applications. Switching speeds have been enhanced over conventional sense amplifiers by application of Schottky technology, and TRI-STATE® strobing is incorporated, offering a high impedance output state for bused organization. The DS1651/DS3651 has active pull-up outputs and offers open collector outputs providing implied "AND" operations.

#### Features

- High speed
- TTL compatible
- Input sensitivity —  $\pm 7$  mV
- TRI-STATE outputs for high speed buses
- Standard supply voltages —  $\pm 5$ V
- Pin and function compatible with MC3430

#### Connection Diagram

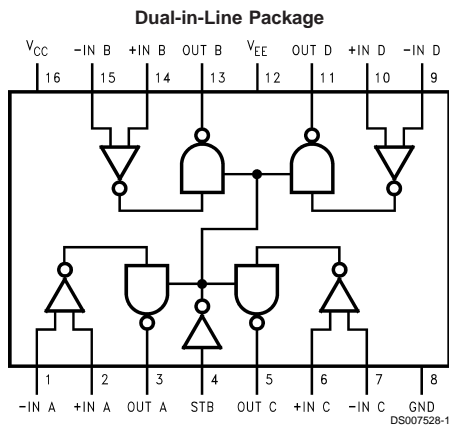

#### Truth Table

Input	Strobe	Output
		DS3651
$V_{ID} \geq 7$ mV $T_A = 0^\circ\text{C to } +70^\circ\text{C}$	L	H
$-7$ mV $\leq V_{ID} \leq +7$ mV $T_A = 0^\circ\text{C to } +70^\circ\text{C}$	H	Open
$V_{ID} \leq -7$ mV $T_A = 0^\circ\text{C to } +70^\circ\text{C}$	L	L
	H	Open

L = Low logic state  
H = High logic state  
Open = TRI-STATE  
X = Indeterminate state

## Typical Applications

A Typical MOS Memory Sensing Application for a 4k word by 4-bit Memory Arrangement Employing 1103 Type Memory Devices

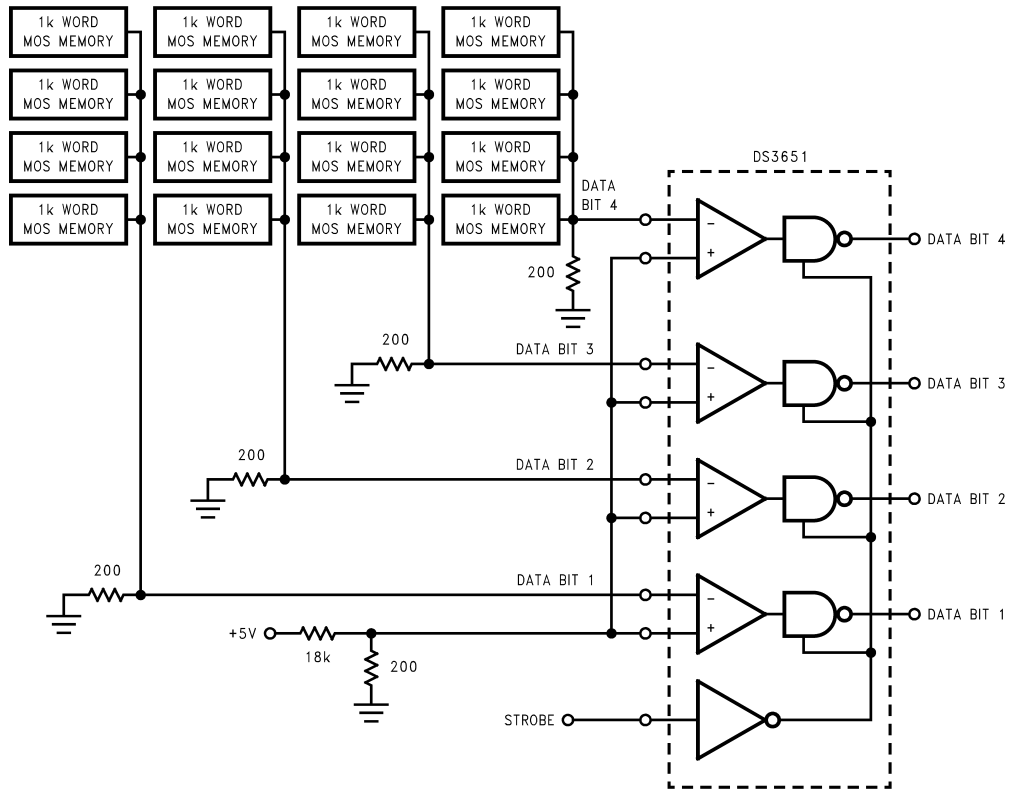

DS007528-2

**Note:** Only 4 devices are required for a 4k word by 16-bit memory system.

## Absolute Maximum Ratings (Note 2)

If Military/Aerospace specified devices are required, please contact the National Semiconductor Sales Office/Distributors for availability and specifications.

### Power Supply Voltages

$V_{CC}$	+7 $V_{DC}$
$V_{EE}$	-7 $V_{DC}$

### Differential-Mode Input Signal Voltage Range, $V_{IDR}$

	$\pm 6 V_{DC}$
--	----------------

### Common-Mode Input Voltage Range, $V_{ICR}$

	$\pm 5 V_{DC}$
--	----------------

### Strobe Input Voltage, $V_{I(S)}$

	5.5 $V_{DC}$
--	--------------

### Strobe Temperature Range

	-65°C to +150°C
--	-----------------

### Maximum Power Dissipation (Note 1) at 25°C

Cavity Package	1509 mW
Molded Package	1476 mW

### Lead Temp. (Soldering, 10 seconds)

	300°C
--	-------

## Operating Conditions

	Min	Max	Unit
Supply Voltage ( $V_{CC}$ )			
DS1651	4.5	5.5	V
DS3651	4.75	5.25	V
Supply Voltage ( $V_{EE}$ )			
DS1651	-4.5	-5.5	V
DS3651	-4.75	-5.25	V
Operating Temperature ( $T_A$ )			
DS1651	-55	+125	°C
DS3651	0	+70	°C
Output Load Current, ( $I_{OL}$ )		16	mA
Differential Mode Input Voltage Range, ( $V_{IDR}$ )	-5.0	+5.0	V
Common-Mode Input Voltage Range, ( $V_{ICR}$ )	-3.0	+3.0	V
Input Voltage Range (Any Input to GND), ( $V_{IR}$ )	-5.0	+3.0	V

## Electrical Characteristics

$V_{CC} = 5 V_{DC}$ ;  $V_{EE} = -5 V_{DC}$ ;  $Min \leq T_A \leq Max$ , unless otherwise noted (Notes 3, 4)

Symbol	Parameter	Conditions	Min	Typ	Max	Unit		
$V_{IS}$	Input Sensitivity (Note 6) (Common-Mode Voltage Range) $V_{ICR} = -3V \leq V_{IN} \leq +3V$	$Min \leq V_{CC} \leq Max$ $Min \geq V_{EE} \geq Max$			$\pm 7.0$	mV		
$V_{IO}$	Input Offset Voltage			2		mV		
$I_{IB}$	Input Bias Current	$V_{CC} = Max, V_{EE} = Max$			20	$\mu A$		
$I_{IO}$	Input Offset Current			0.5		$\mu A$		
$V_{IL(S)}$	Strobe Input Voltage (Low State)				0.8	V		
$V_{IH(S)}$	Strobe Input Voltage (High State)		2			V		
$I_{IL(S)}$	Strobe Current (Low State)	$V_{CC} = Max, V_{EE} = Max, V_{IN} = 0.4V$			-1.6	mA		
$I_{IL(S)}$	Strobe Current (High State)	$V_{CC} = Max, V_{EE} = Max$	$V_{IN} = 2.4V$	DS3651		40	$\mu A$	
			$V_{IN} = V_{CC}$			1	mA	
		$V_{CC} = Max, V_{EE} = Max$	$V_{IN} = 2.4V$	DS1651			100	$\mu A$
			$V_{IN} = V_{CC}$				1	mA
$V_{OH}$	Output Voltage (High States)	$V_{CC} = Min, V_{EE} = Min$ $I_O = -400 \mu A$	2.4			V		
$V_{OL}$	Output Voltage (Low State)	$V_{CC} = Min, V_{EE} = Min$ $I_O = 16 mA$	DS3651			0.45	V	
			DS1651				0.50	V
$I_{OS}$	Output Current Short Circuit	$V_{CC} = Max, V_{EE} = Max, (Note 5)$	DS1651/DS3651	-18		-70	mA	
$I_{OFF}$	Output Disable Leakage Current	$V_{CC} = Max, V_{EE} = Max$	DS3651			40	$\mu A$	
			DS1651				100	$\mu A$
$I_{CC}$	High Logic Level Supply Current	$V_{CC} = Max, V_{EE} = Max$		45	60	mA		
$I_{EE}$	High Logic Level Supply Current	$V_{CC} = Max, V_{EE} = Max$		-17	-30	mA		

## Switching Characteristics

$V_{CC} = 5 V_{DC}$ ,  $V_{EE} = -5 V_{DC}$ ,  $T_A = 25^\circ C$  unless otherwise noted.

Symbol	Parameter	Conditions		Min	Typ	Max	Units
$t_{PHL(D)}$	High-to-Low Logic Level Propagation Delay Time (Differential Inputs)	5 mV + $V_{IS}$ , (Figure 2)	DS1651/ DS3651		23	45	ns
$t_{PLH(D)}$	Low-to-High Logic Level Propagation Delay Time (Differential Inputs)	5 mV + $V_{IS}$ , (Figure 2)	DS1651/ DS3651		22	55	ns
$t_{POH(S)}$	TRI-STATE to High Logic Level Propagation Delay Time (Strobe)	(Figure 1)	DS1651/ DS3651		16	21	ns
$t_{PHO(S)}$	High Logic Level to TRI-STATE Propagation Delay Time (Strobe)	(Figure 1)	DS1651/ DS3651		7	18	ns
$t_{POL(S)}$	TRI-STATE to Low Logic Level Propagation Delay Time (Strobe)	(Figure 1)	DS1651/ DS3651		19	27	ns
$t_{PLO(S)}$	Low Logic Level to TRI-STATE Propagation Delay Time (Strobe)	(Figure 1)	DS1651/ DS3651		14	29	ns

**Note 1:** Derate cavity package 10.1 mW/°C above 25°C; derate molded package 11.8 mW/°C above 25°C.

**Note 2:** "Absolute Maximum Ratings" are those values beyond which the safety of the device cannot be guaranteed. Except for "Operating Temperature Range" they are not meant to imply that the device should be operated at these limits. The table of "Electrical Characteristics" provides conditions for actual device operation.

**Note 3:** Unless otherwise specified min/max limits apply across the 0°C to +70°C range for the DS3651 and across the -55°C to +125°C range for the DS1651. All typical values are for  $T_A = 25^\circ C$ ,  $V_{CC} = 5V$  and  $V_{EE} = -5V$ .

**Note 4:** All currents into device pins shown as positive, out of device pins as negative, all voltages referenced to ground unless otherwise noted. All values shown as max or min on absolute value basis.

**Note 5:** Only one output at a time should be shorted.

**Note 6:** A parameter which is of primary concern when designing with sense amplifiers is, what is the minimum differential input voltage required at the sense amplifier input terminals to guarantee a given output logic state. This parameter is commonly referred to as threshold voltage. It is well known that design considerations of threshold voltage are plagued by input offset currents, bias currents, network source resistances, and voltage gain. As a design convenience, the DS1651 and DS3651 are specified to a parameter called input sensitivity ( $V_{IS}$ ). This parameter takes into consideration input offset currents and bias currents, and guarantees a minimum input differential voltage to cause a given output logic state with respect to a maximum source impedance of 200Ω at each input.

## Switching Time Waveform

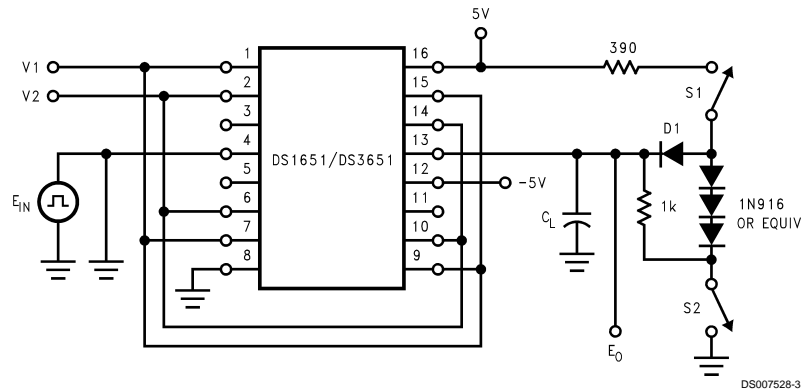

**Note:** Output of channel B shown under test, other channels are tested similarly.

Delay	V1	V2	S1	S2	$C_L$
$t_{PLO(S)}$	100 mV	GND	Closed	Closed	15 pF
$t_{POL(S)}$	100 mV	GND	Closed	Open	50 pF
$t_{PHO(S)}$	GND	100 mV	Closed	Closed	15 pF
$t_{POH(S)}$	GND	100 mV	Open	Closed	50 pF

$C_L$  includes jig and probe capacitance.

$E_{IN}$  waveform characteristics:  $t_{TLH}$  and  $t_{THL} \leq 10$  ns measured 10% to 90%

PRR = 1 MHz

Duty cycle = 50%

## AC Test Circuits

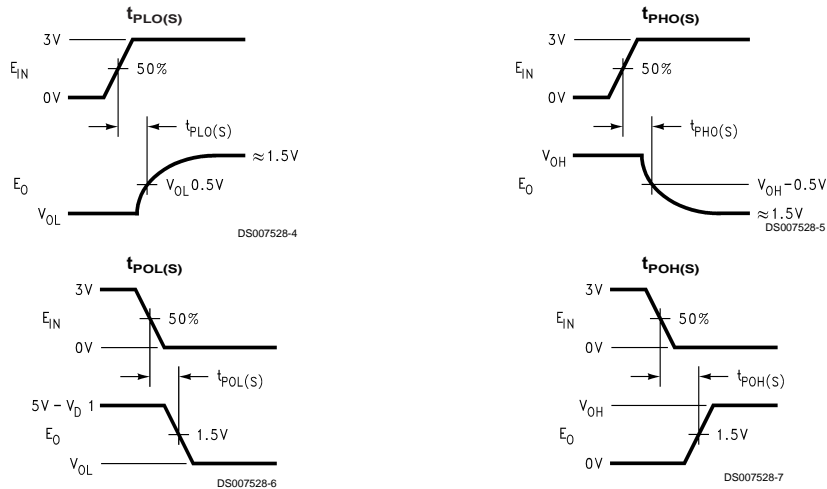
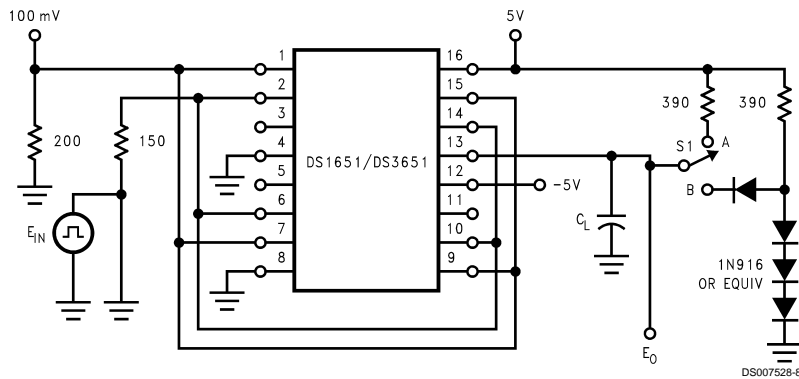
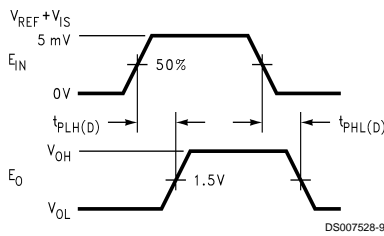

FIGURE 1. Strobe Propagation Delay  $t_{PLO}(S)$ ,  $t_{POL}(S)$ ,  $t_{PHL}(S)$  and  $t_{POH}(S)$



Note: Output of channel B shown under test, other channels are tested similarly. S1 at "B" for DS1651/DS3651,  $C_L = 50$  pF total for DS1651/DS3651.



$E_{IN}$  waveform characteristics:  
 $t_{RLH}$  and  $t_{THL} \leq 10$  ns measured 10% to 90%  
 PRR = 1 MHz, duty cycle = 500 ns

FIGURE 2. Differential Input Propagation Delay  $t_{PLH}(D)$  and  $t_{PHL}(D)$

# Schematic Diagrams

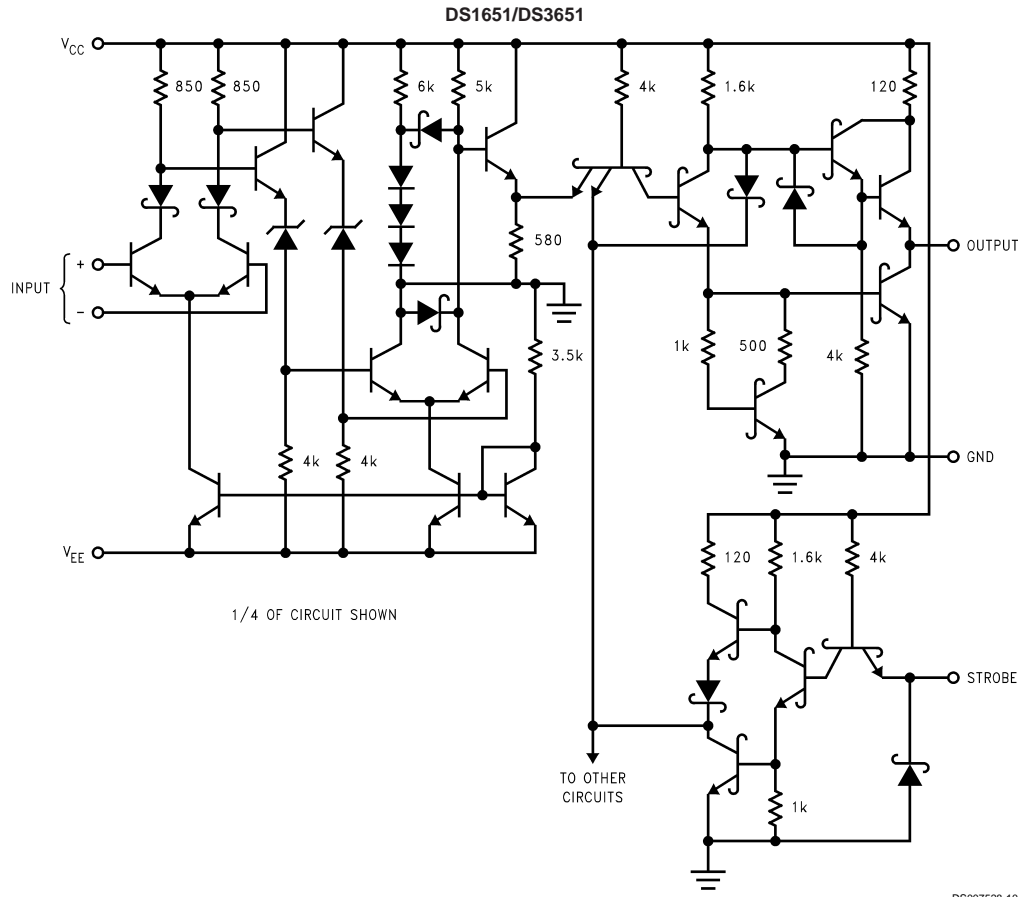

## Typical Applications

**Level Detector with Hysteresis**

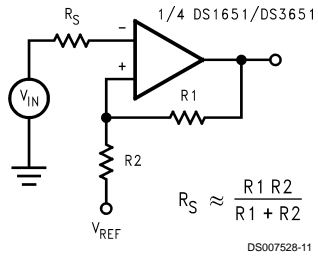

**Transfer Characteristics and Equations for Level Detector with Hysteresis**

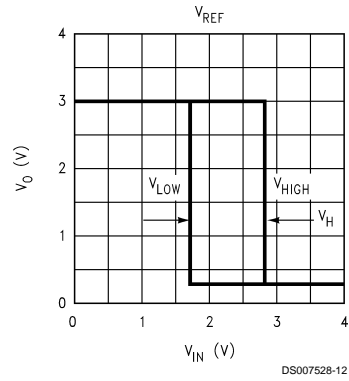

$$V_{HIGH} = V_{REF} + \frac{R_2 [V_{O(MAX)} - V_{REF}]}{R_1 + R_2}$$

$$V_{LOW} = V_{REF} + \frac{R_2 [V_{O(MIN)} - V_{REF}]}{R_1 + R_2}$$

Hysteresis Loop ( $V_H$ )

$$V_H = V_{HIGH} - V_{LOW} = \frac{R_2}{R_1 + R_2} [V_{O(MAX)} - V_{O(MIN)}]$$



**Physical Dimensions** inches (millimeters) unless otherwise noted

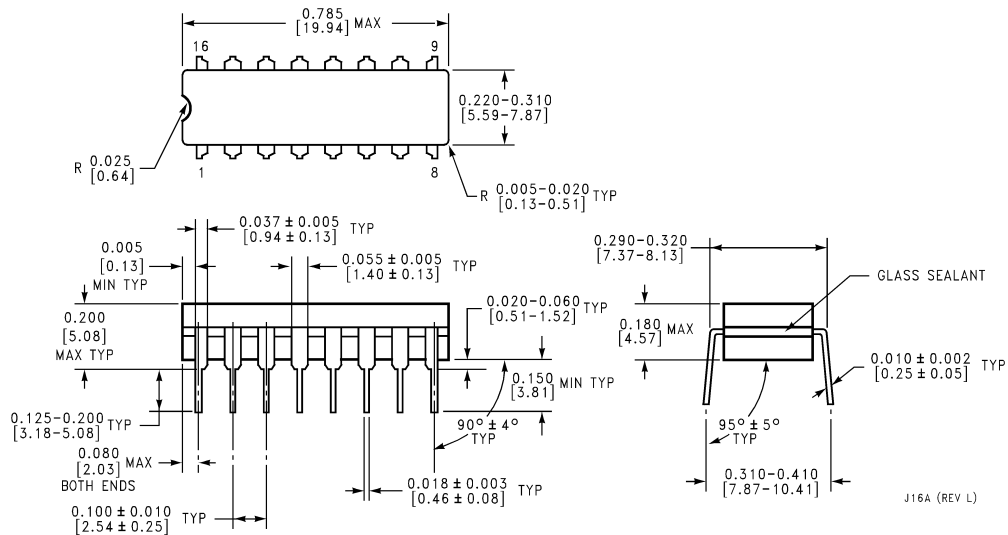

**Ceramic Dual-in-Line Package (J)**  
**Order Number DS1651J, DS1653J, DS3651J or DS3653J**  
**NS Package Number J16A**

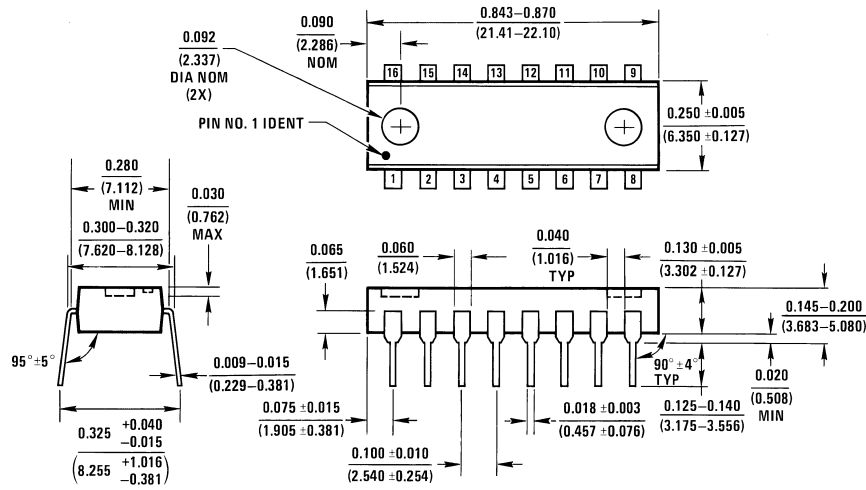

**Molded Dual-in-Line Package (N)**  
**Order Number DS3651N or DS3653N**  
**NS Package Number N16A**

## Notes

### LIFE SUPPORT POLICY

NATIONAL'S PRODUCTS ARE NOT AUTHORIZED FOR USE AS CRITICAL COMPONENTS IN LIFE SUPPORT DEVICES OR SYSTEMS WITHOUT THE EXPRESS WRITTEN APPROVAL OF THE PRESIDENT AND GENERAL COUNSEL OF NATIONAL SEMICONDUCTOR CORPORATION. As used herein:

1. Life support devices or systems are devices or systems which, (a) are intended for surgical implant into the body, or (b) support or sustain life, and whose failure to perform when properly used in accordance with instructions for use provided in the labeling, can be reasonably expected to result in a significant injury to the user.
2. A critical component is any component of a life support device or system whose failure to perform can be reasonably expected to cause the failure of the life support device or system, or to affect its safety or effectiveness.



**National Semiconductor Corporation**  
Americas  
Tel: 1-800-272-9959  
Fax: 1-800-737-7018  
Email: support@nsc.com

[www.national.com](http://www.national.com)

**National Semiconductor Europe**

Fax: +49 (0) 1 80-530 85 86  
Email: europe.support@nsc.com  
Deutsch Tel: +49 (0) 1 80-530 85 85  
English Tel: +49 (0) 1 80-532 78 32  
Français Tel: +49 (0) 1 80-532 93 58  
Italiano Tel: +49 (0) 1 80-534 16 80

**National Semiconductor Asia Pacific Customer Response Group**

Tel: 65-2544466  
Fax: 65-2504466  
Email: sea.support@nsc.com

**National Semiconductor Japan Ltd.**

Tel: 81-3-5639-7560  
Fax: 81-3-5639-7507

This datasheet has been downloaded from:

[www.DatasheetCatalog.com](http://www.DatasheetCatalog.com)

Datasheets for electronic components.

# National Semiconductor was acquired by Texas Instruments.

[http://www.ti.com/corp/docs/investor\\_relations/pr\\_09\\_23\\_2011\\_national\\_semiconductor.html](http://www.ti.com/corp/docs/investor_relations/pr_09_23_2011_national_semiconductor.html)

This file is the datasheet for the following electronic components:

DS3651J - <http://www.ti.com/product/ds3651j?HQS=TI-null-null-dscatalog-df-pf-null-wwe>

DS3651N - <http://www.ti.com/product/ds3651n?HQS=TI-null-null-dscatalog-df-pf-null-wwe>



LittleDiode supplies new, hard to find or obsolete electronic components and semiconductors all over the world.

With over two million different components listed you are sure to find the part you need.

Feel free to visit us today at our online store:

[LittleDiode.com](http://LittleDiode.com)

Looking forward to providing you with the best possible service.