

DS3662 Quad High Speed Trapezoidal™ Bus Transceiver

General Description

The DS3662 is a quad high speed Schottky bus transceiver intended for use with terminated 120Ω impedance lines. It is specifically designed to reduce noise in unbalanced transmission systems. The open collector drivers generate precise trapezoidal waveforms with rise and fall times of 15 ns (typical), which are relatively independent of capacitive loading conditions on the outputs. This reduces noise coupling to the adjacent lines without any appreciable impact on the maximum data rate obtainable with high speed bus transceivers. In addition, the receivers use a low pass filter in conjunction with a high speed comparator, to further enhance the noise immunity. Tightly controlled threshold levels on the receiver provide equal rejection to both negative and positive going noise pulses on the bus.

The external termination is intended to be a 180Ω resistor from the bus to 5V logic supply, together with a 390Ω resistor from the bus to ground. The bus can be terminated at one or both ends. A two input NOR gate is provided to disable all drivers in a package simultaneously.

Features

- Pin to pin functional replacement for DS8641
- Guaranteed AC specifications on noise immunity and propagation delay over the specified temperature and supply voltage range
- Temperature insensitive receiver thresholds track bus logic level
- Trapezoidal bus waveforms reduce noise coupling to adjacent lines
- Precision receiver thresholds provide maximum noise immunity and symmetrical response to positive and negative going pulses
- Open collector driver output allows wire-OR connection
- High speed Schottky technology
- $15\ \mu\text{A}$ typical bus termination current with normal V_{CC} or with $V_{CC} = 0\text{V}$
- Glitch free power up/down protection on the driver output
- TTL compatible driver and disable inputs, and receiver outputs

Block and Connection Diagram

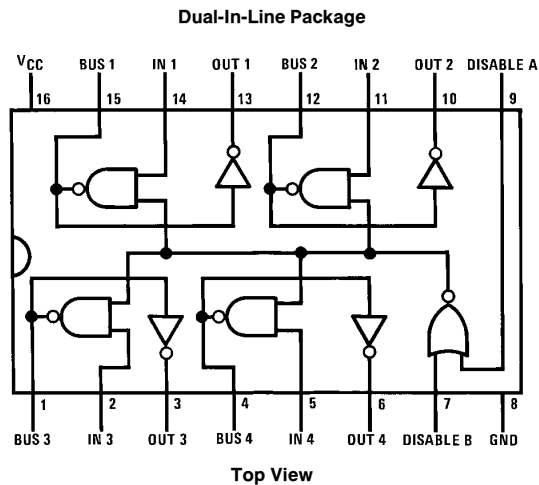

TL/F/5803-1

Order Number DS3662J, DS3662N or DS3662WM
See NS Package Number J16A, N16A or M16B

Trapezoidal™ is a trademark of National Semiconductor Corp.

Absolute Maximum Ratings (Note 1)

If Military/Aerospace specified devices are required, please contact the National Semiconductor Sales Office/Distributors for availability and specifications.

Supply Voltage	7V
Input and Output Voltage	5.5V
Storage Temperature Range	-65°C to +150°C
Maximum Power Dissipation* at 25°C	
Cavity Package	1509 mW
Molded Package	1476 mW
Lead Temperature (Soldering, 4 sec.)	260°C

Recommended Operating Conditions

	Min	Max	Units
Supply Voltage (V_{CC})	4.75	5.25	V
Temperature Range (T_A)	0	70	°C

*Derate cavity package 10.1 mW/°C above 25°C; derate molded package 11.8 mW/°C above 25°C.

Electrical Characteristics (Notes 2 and 3)

Symbol	Parameter	Conditions	Min	Typ	Max	Units
DRIVER AND DISABLE INPUTS						
V_{IH}	Logical "1" Input Voltage		2.0			V
V_{IL}	Logical "0" Input Voltage				0.8	V
I_I	Logical "1" Input Current	$V_{IN} = 5.5V$			1	mA
I_{IH}	Logical "1" Input Current	$V_{IN} = 2.4V$			40	μA
I_{IL}	Logical "0" Input Current	$V_{IN} = 0.4V$		-1	-1.6	mA
V_{CL}	Input Diode Clamp Voltage	$I_{CLAMP} = -12\text{ mA}$		-0.8	-1.5	V
DRIVER OUTPUT/RECEIVER INPUT						
V_{OLB}	Low Level Bus Voltage	$V_{DIS} = 0.8V, V_{IN} = 2V, I_{BUS} = 100\text{ mA}$		0.6	0.9	V
I_{IHB}	Maximum Bus Current	$V_{IN} = 0.8V, V_{BUS} = 4V, V_{CC} = 5.25V$		10	100	μA
I_{ILB}	Maximum Bus Current	$V_{IN} = 0.8V, V_{BUS} = 4V, V_{CC} = 0V$			100	μA
V_{IH}	High Level Receiver Threshold	$V_{IN} = 0.8V, V_{OL} = 16\text{ mA}$	1.90	1.70		V
V_{IL}	Low Level Receiver Threshold	$V_{IN} = 0.8V, I_{OH} = -400\text{ }\mu A$		1.70	1.50	V
RECEIVER OUTPUT						
V_{OH}	Logical "1" Output Voltage	$V_{IN} = 0.8V, V_{BUS} = 0.5V, I_{OH} = -400\text{ }\mu A$	2.4	3.2		V
V_{OL}	Logical "0" Output Voltage	$V_{IN} = 0.8V, V_{BUS} = 4V, I_{OL} = 16\text{ mA}$		0.35	0.5	V
I_{OS}	Output Short Circuit Current	$V_{DIS} = 0.8V, V_{IN} = 0.8V, V_{BUS} = 0.5V, V_{OS} = 0V, V_{CC} = 5.25V, (\text{Note } 4)$	-40	-70	-100	mA
I_{CC}	Supply Current	$V_{DIS} = 0V, V_{IN} = 2V$		50	90	mA

Switching Characteristics (Notes 2 and 3)

Symbol	Parameter	Conditions	Min	Typ	Max	Units
PROPAGATION DELAYS						
t_{PLHD}	Disable to Bus "1"	Figure 1		25	35	ns
t_{PHLD}	Disable to Bus "0"			25	35	ns
t_{PLHB}	Driver Input to Bus "1"	Figure 2		20	30	ns
t_{PHLB}	Driver Input to Bus "0"			20	30	ns
t_{PLHR}	Bus to Logical "1" Receiver Output	Figure 3		25	40	ns
t_{PHLR}	Bus to Logical "0" Receiver Output			25	40	ns
NOISE IMMUNITY						
t_{rB}, t_{fB}	Rise and Fall Times (10%–90%) of the Driver Output	Figure 2	10	15	20	ns
t_{nR}	Receiver Noise Rejection Pulse Width	No Response at Receiver Output as per Figure 4		20	10	ns

Note 1: "Absolute Maximum Ratings" are those values beyond which the safety of the device cannot be guaranteed. They are not meant to imply that the devices should be operated at these limits. The tables of "Electrical Characteristics" and "Recommended Operating Conditions" provide conditions for actual device operation.

Note 2: Unless otherwise specified min/max limits apply across the supply and temperature range listed in the table of "Recommended Operating Conditions". All typical values are for $T_A = 25^\circ\text{C}$ and $V_{CC} = 5V$.

Note 3: All currents into device pins shown as positive, out of device pins as negative, all voltages referenced to ground unless otherwise noted. All values shown as max or min on absolute value basis.

Note 4: Only one output at a time should be shorted.

AC Test Circuits and Switching Waveforms

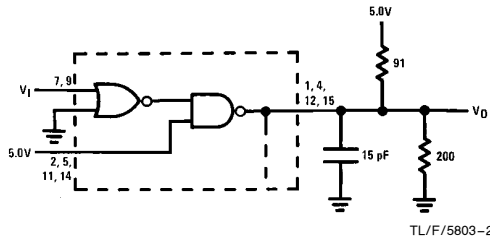

TL/F/5803-2

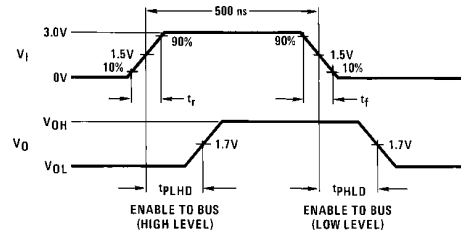

TL/F/5803-3

Note: $t_r = t_f = 2.5$ ns. Pulse width = 500 ns measured between 1.5V levels. $f = 1$ MHz.
FIGURE 1. Disable Delays

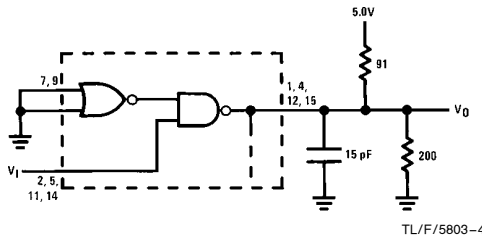

TL/F/5803-4

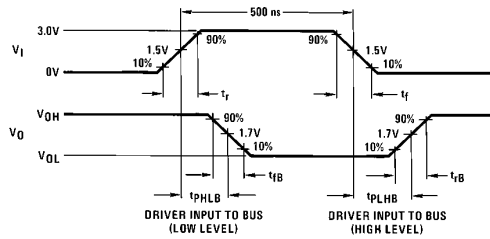

TL/F/5803-5

Note: $t_r = t_f = 2.5$ ns. Pulse width = 500 ns measured between 1.5V levels. $f = 1$ MHz.
FIGURE 2. Driver Propagation Delays

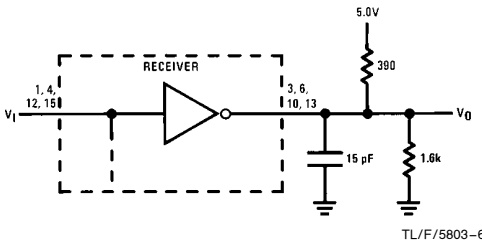

TL/F/5803-6

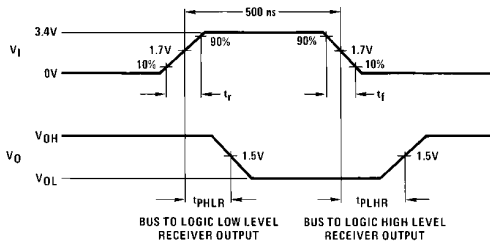

TL/F/5803-7

Note: $t_r = t_f = 15$ ns. Pulse width = 500 ns measured between 1.7V levels. $f = 1$ MHz.
FIGURE 3. Receiver Propagation Delays

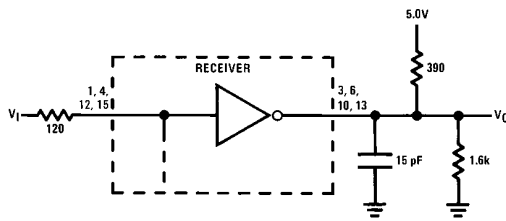

TL/F/5803-8

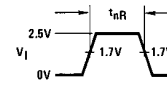

TL/F/5803-9

$t_r = t_f = 2.5$ ns
(a) Receiver Output (V_O) to Remain Greater than 2.2V

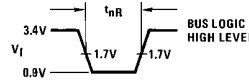

TL/F/5803-10

$t_r = t_f = 2.5$ ns
(b) Receiver Output (V_O) to Remain Less than 0.7V

FIGURE 4. Receiver Noise Immunity: "No Response at Output" Input Waveforms

Typical Application

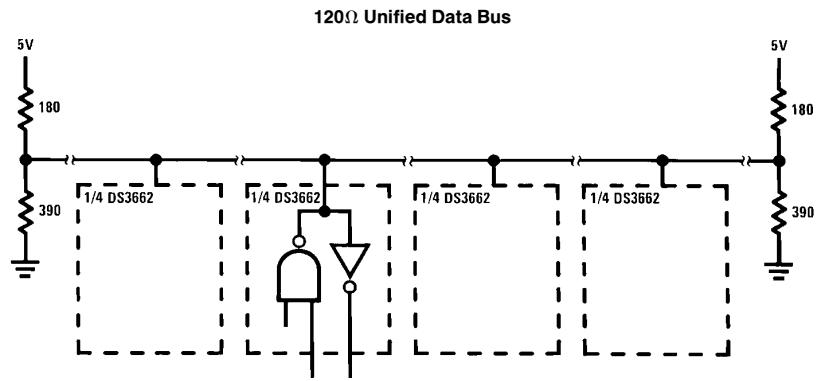

TL/F/5803-11

Physical Dimensions inches (millimeters)

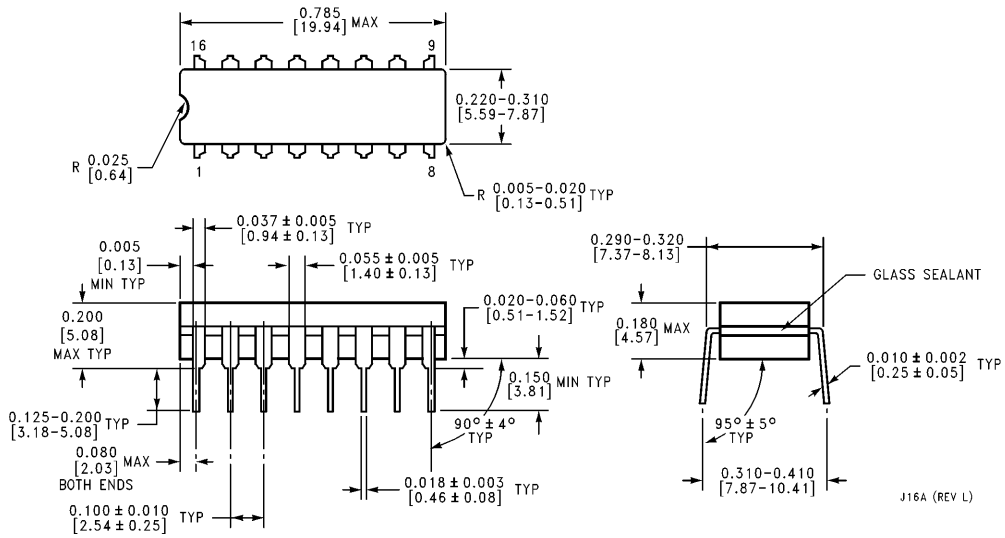

Ceramic Dual-In-Line Package (J)
Order Number DS3662J
NS Package Number J16A

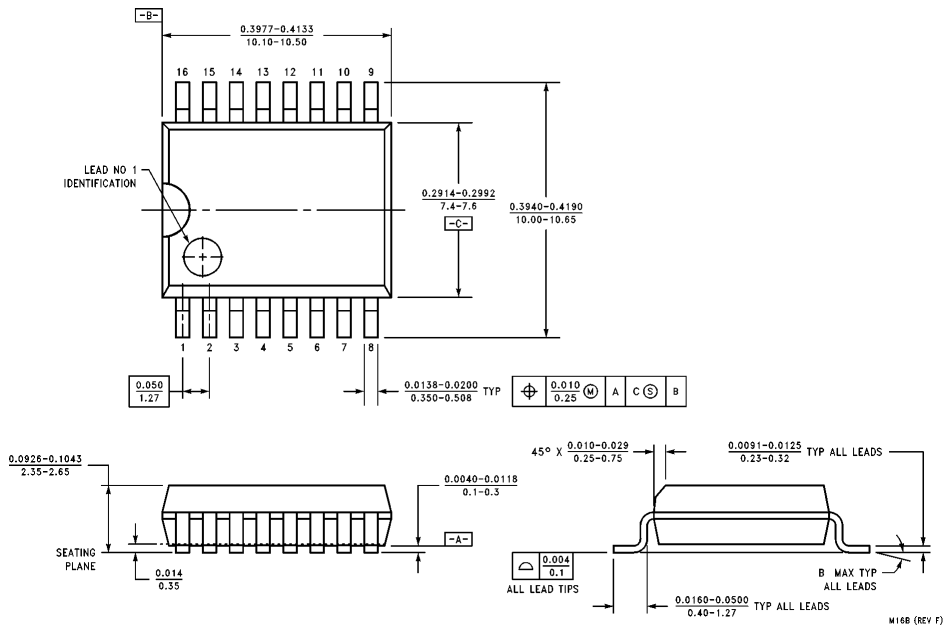

16-Lead Molded Small Outline Package (M)
Order Number DS3662WM
NS Package Number M16B

Physical Dimensions inches (millimeters) (Continued)

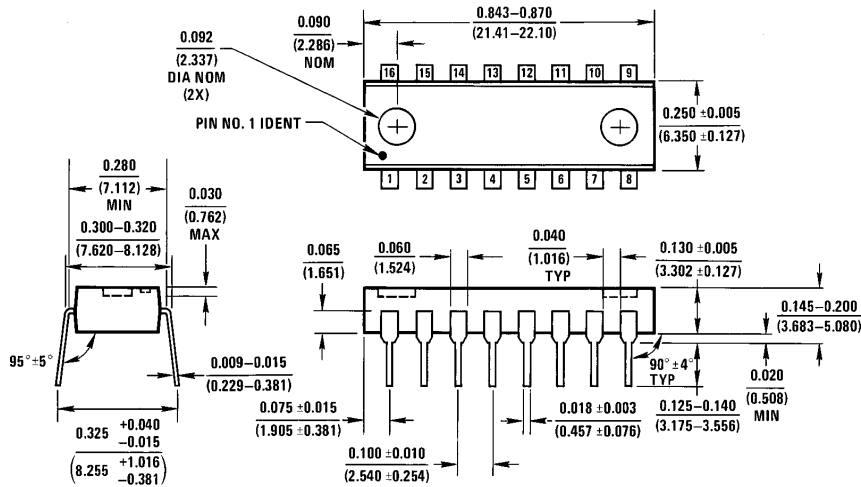

Molded Dual-In-Line Package (N)
Order Number DS3662N
NS Package Number N16A

N16A (REV E)

LIFE SUPPORT POLICY

NATIONAL'S PRODUCTS ARE NOT AUTHORIZED FOR USE AS CRITICAL COMPONENTS IN LIFE SUPPORT DEVICES OR SYSTEMS WITHOUT THE EXPRESS WRITTEN APPROVAL OF THE PRESIDENT OF NATIONAL SEMICONDUCTOR CORPORATION. As used herein:

1. Life support devices or systems are devices or systems which, (a) are intended for surgical implant into the body, or (b) support or sustain life, and whose failure to perform, when properly used in accordance with instructions for use provided in the labeling, can be reasonably expected to result in a significant injury to the user.
2. A critical component is any component of a life support device or system whose failure to perform can be reasonably expected to cause the failure of the life support device or system, or to affect its safety or effectiveness.



National Semiconductor Corporation
 1111 West Bardin Road
 Arlington, TX 76017
 Tel: 1(800) 272-9959
 Fax: 1(800) 737-7018

<http://www.national.com>

National Semiconductor Europe

Fax: +49 (0) 180-530 85 86
 Email: europe.support@nsc.com
 Deutsch Tel: +49 (0) 180-530 85 85
 English Tel: +49 (0) 180-532 78 32
 Français Tel: +49 (0) 180-532 93 58
 Italiano Tel: +49 (0) 180-534 16 80

National Semiconductor Hong Kong Ltd.

19th Floor, Straight Block,
 Ocean Centre, 5 Canton Rd.
 Tsimshatsui, Kowloon
 Hong Kong
 Tel: (852) 2737-1600
 Fax: (852) 2736-9960

National Semiconductor Japan Ltd.

Tel: 81-043-299-2308
 Fax: 81-043-299-2408

National does not assume any responsibility for use of any circuitry described, no circuit patent licenses are implied and National reserves the right at any time without notice to change said circuitry and specifications.

National Semiconductor was acquired by Texas Instruments.

http://www.ti.com/corp/docs/investor_relations/pr_09_23_2011_national_semiconductor.html

This file is the datasheet for the following electronic components:

DS3662 - <http://www.ti.com/product/ds3662?HQS=TI-null-null-dscatalog-df-pf-null-ww>



LittleDiode supplies new, hard to find or obsolete electronic components and semiconductors all over the world.

With over two million different components listed you are sure to find the part you need.

Feel free to visit us today at our online store:

LittleDiode.com

Looking forward to providing you with the best possible service.