

DS3862

Octal High Speed Trapezoidal Bus Transceiver

General Description

The DS3862 is an octal high speed schottky bus transceiver intended for use with terminated 120Ω impedance lines. It is specifically designed to reduce noise in unbalanced transmission systems. The open collector drivers generate precise trapezoidal waveforms with rise and fall times of 9 ns (typical), which are relatively independent of capacitive loading conditions on the outputs. This reduces noise coupling to the adjacent lines without any appreciable impact on the maximum data rate obtainable with high speed bus transceivers. In addition, the receivers use a low pass filter in conjunction with a high speed comparator, to further enhance the noise immunity. Tightly controlled threshold levels on the receiver provide equal rejection to both negative and positive going noise pulses on the bus.

The external termination is intended to be a 180Ω resistor from the bus to 5V logic supply, together with a 390Ω resistor from the bus to ground. The bus can be terminated at one or both ends.

Features

- Guaranteed A.C. specifications on noise immunity and propagation delay over the specified temperature and supply voltage range
- Temperature insensitive receiver thresholds track bus logic level and respond symmetrically to positive and negative going pulses
- Trapezoidal bus waveforms reduce noise coupling to adjacent lines
- Open collector driver output allows wire-or connection
- Advanced low power schottky technology
- Glitch free power up/down protection on driver and receiver outputs
- TTL compatible driver and control inputs, and receiver outputs
- Control logic is the same as the DS3896

Logic and Connection Diagram

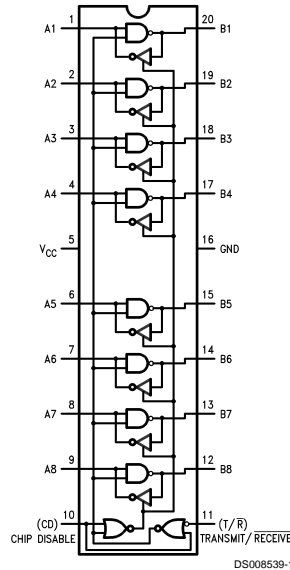

Order Number DS3862J, DS3862N or DS3862WM
See NS Package Number J20A, N20A or M20B

Absolute Maximum Ratings (Note 1)

If Military/Aerospace specified devices are required, please contact the National Semiconductor Sales Office/Distributors for availability and specifications.

Supply Voltage	6V
Control Input Voltage	5.5V
Driver Input and Receiver Output	5.5V
Receiver Input and Driver Output	5.5V
Power Dissipation	1400 mW

Storage Temperature Range	-65°C to +150°C
Lead Temperature (Soldering, 4 seconds)	260°C

Recommended Operating Conditions

	Min	Max	Units
Supply Voltage, V_{CC}	4.75	5.25	V
Operating Free Air Temperature	0	70	°C

Electrical Characteristics (Notes 2, 3)

$0^{\circ}\text{C} \leq T_A \leq 70^{\circ}\text{C}$, $4.75\text{V} \leq V_{CC} \leq 5.25\text{V}$ unless otherwise specified

Symbol	Parameter	Conditions	Min	Typ	Max	Units
Driver and Control Inputs:						
V_{IH}	Logical "1" Input Voltage		2.0			V
V_{IL}	Logical "0" Input Voltage				0.8	V
I_I	Logical "1" Input Current	$A_n = V_{CC}$			1	mA
I_{IH}	Logical "1" Input Current	$A_n = 2.4\text{V}$			40	μA
I_{IHC}	Logical "1" Input Current	$CD = T/\bar{R} = 2.4\text{V}$			80	μA
I_{IL}	Logical "0" Input Current	$A_n = 0.4\text{V}$		-1	-1.6	mA
I_{ILC}	CD & T/\bar{R} Logical "0" Input Current	$CD = T/\bar{R} = 0.4\text{V}$		-180	-400	μA
V_{CL}	Input Diode Clamp Voltage	$I_{clamp} = -12\text{mA}$		-0.9	-1.5	V
Driver Output/Receiver Input						
V_{OLB}	Low Level Bus Voltage	$A_n = T/\bar{R} = 2\text{V}$, $I_{bus} = 100\text{mA}$		0.6	0.9	V
I_{IHB}	Logical "1" Bus Current	$A_n = 0.8\text{V}$, $B_n = 4\text{V}$, $V_{CC} = 5.25\text{V}$ and 0V		10	100	μA
I_{ILB}	Logical "0" Bus Current	$A_n = 0.8\text{V}$, $B_n = 0\text{V}$, $V_{CC} = 5.25\text{V}$ and 0V			100	μA
V_{TH}	Input Threshold	$V_{CC} = 5\text{V}$	1.5	1.7	1.9	V
Receiver Output						
V_{OH}	Logical "1" Output Voltage	$B_n = 0.9\text{V}$, $I_{oh} = -400\mu\text{A}$	2.4	3.2		V
V_{OL}	Logical "0" Output Voltage	$B_n = 4\text{V}$, $I_{ol} = 16\text{mA}$		0.35	0.5	V
I_{OS}	Output Short Circuit Current	$B_n = 0.9\text{V}$	-20	-70	-100	mA
I_{CC}	Supply Current	$V_{CC} = 5.25\text{V}$		90	135	mA

Note 1: "Absolute Maximum Ratings" are those beyond which the safety of the device cannot be guaranteed. They are not meant to imply that device should be operated at these limits. The table of "Electrical Characteristics" provide conditions for actual device operation.

Note 2: All currents into device pins are positive; all currents out of device pins are negative. All voltages are referenced to device ground unless otherwise specified.

Note 3: All typicals are given for $V_{CC} = 5\text{V}$ and $T_A = 25^{\circ}\text{C}$.

Switching Characteristics

$0^{\circ}\text{C} \leq T_A \leq 70^{\circ}\text{C}$, $4.75\text{V} \leq V_{CC} \leq 5.25\text{V}$ unless otherwise specified

Symbol	Parameter	Conditions	Min	Typ	Max	Units
Driver:						
t_{DLH}	An to Bn	$CD = 0.8\text{V}$, $T/\bar{R} = 2.0\text{V}$, $V_L = 5\text{V}$ (Figure 1)		12	20	ns
t_{DHL}				12	20	ns
t_{DLHC}	CD to Bn	$A_n = T/\bar{R} = 2.0\text{V}$, $V_L = 5\text{V}$, (Figure 1)		12	20	ns
t_{DHLC}				15	25	ns
t_{DLHT}	T/\bar{R} to Bn	$V_{CI} = A_n$, $V_C = 5\text{V}$, (Figure 2)		20	30	ns
t_{DHLT}		$CD = 0.8\text{V}$, $RC = 390\Omega$, $CL = 30\text{pF}$ $RL1 = 91\Omega$, $RL2 = 200\Omega$, $V_L = 5\text{V}$		25	40	ns
t_R	Driver Output Rise Time	$CD = 0.8\text{V}$, $T/\bar{R} = 2\text{V}$, $V_L = 5\text{V}$ (Figure 1)	4	9	20	ns
t_F	Driver Output Fall Time		4	9	20	ns

Switching Characteristics (Continued)

$0^{\circ}\text{C} \leq T_A \leq 70^{\circ}\text{C}$, $4.75\text{V} \leq V_{CC} \leq 5.25\text{V}$ unless otherwise specified

Symbol	Parameter	Conditions	Min	Typ	Max	Units
Receiver:						
t_{RLH}	Bn to An	CD = 0.8V, $T/\bar{R} = 0.8\text{V}$ (Figure 3)		15	25	ns
t_{RHL}				15	25	ns
t_{RLZC}	CD to An	Bn = 2.0V, $T/\bar{R} = 0.8\text{V}$, CL = 5 pF RL1 = 390 Ω , RL2 = NC, VL = 5V (Figure 4)		15	25	ns
t_{RZLC}		Bn = 2.0V, $T/\bar{R} = 0.8\text{V}$, CL = 30 pF RL1 = 390 Ω , RL2 = 1.6K, VL = 5V (Figure 4)		10	20	ns
t_{RHZC}		Bn = 0.8V, $T/\bar{R} = 0.8\text{V}$, VL = 0V, RL1 = 390 Ω , RL2 = NC, CL = 5 pF (Figure 4)		5	10	ns
t_{RZHC}		Bn = 0.8V, $T/\bar{R} = 0.8\text{V}$, VL = 0V, RL1 = NC, RL2 = 1.6K, CL = 30 pF (Figure 4)		8	15	ns
t_{RLZT}	T/\bar{R} to An	VCI = Bn, VC = 3.4V, RC = 39 Ω CD = 0.8V, VL = 5V, RL1 = 390 Ω , RL2 = NC, CL = 5 pF (Figure 2)		20	30	ns
t_{RZLT}		VCI = Bn, VC = 3.4V, RC = 39 Ω , CD = 0.8V, VL = 5V, RL1 = 390 Ω , RL2 = 1.6K, CL = 30 pF (Figure 2)		30	45	ns
t_{RHZT}		VCI = Bn, VC = 0V, RC = 39 Ω CD = 0.8V, VL = 0V, RL1 = 390 Ω , RL2 = NC, CL = 5 pF (Figure 2)		5	10	ns
t_{RZHT}		VCI = Bn, VC = 0V, RC = 39 Ω , CD = 0.8V, VL = 0V, RL1 = 390 Ω , RL2 = 1.6K, CL = 30 pF (Figure 2)		10	20	ns
t_{NR}	Receiver Noise Rejection Pulse Width	(Figure 5)	9	12		ns

Note: NC means open

Switching Waveforms

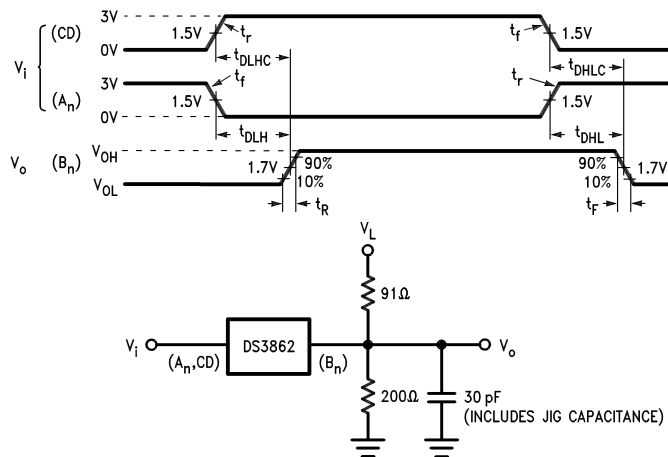

DS008539-2

Note: $t_r = t_f \leq 5$ ns from 10% to 90%

FIGURE 1. Driver Propagation Delays

Switching Waveforms (Continued)

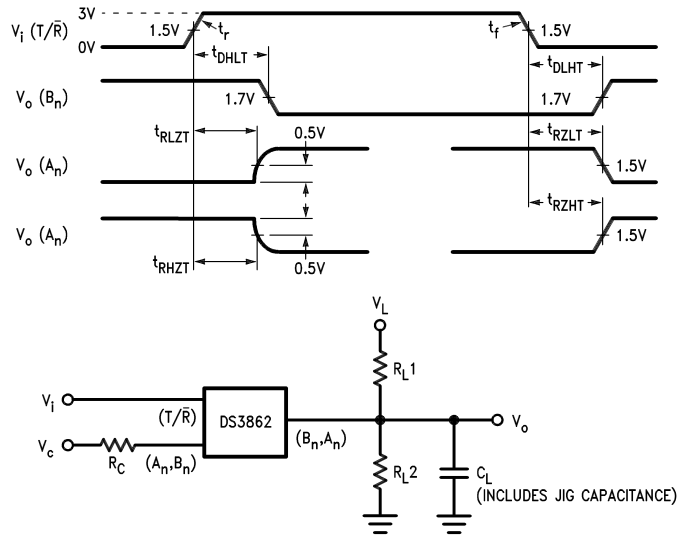

DS008539-3

Note: $t_r = t_f \leq 5$ ns from 10% to 90%

FIGURE 2. Propagation Delay From T/R Pin to A_n or B_n.

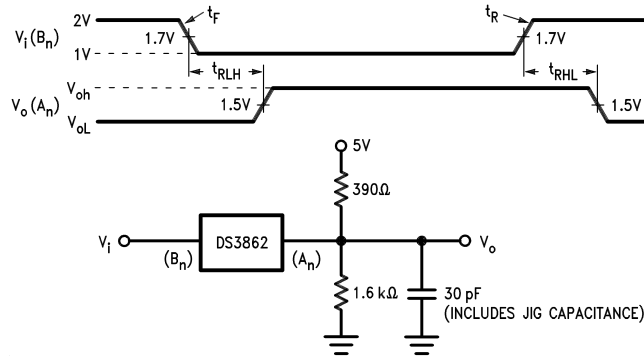

DS008539-4

Note: $t_R = t_F \leq 10$ ns from 10% to 90%

FIGURE 3. Receiver Propagation Delays

Switching Waveforms (Continued)

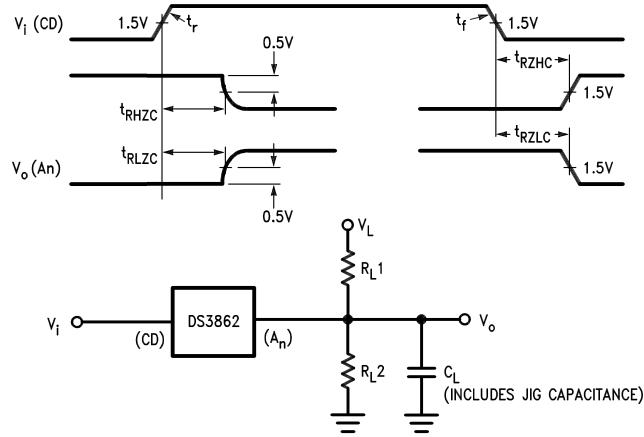

DS008539-5

Note: $t_r = t_f \leq 5$ ns from 10% to 90%

FIGURE 4. Propagation Delay From CD Pin to An

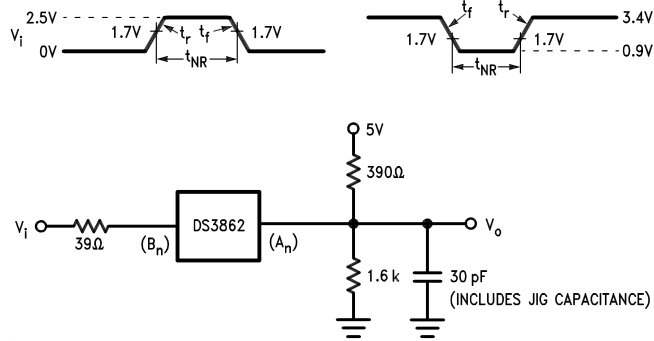

DS008539-6

Note: $t_r = t_f = 2$ ns from 10% to 90%

FIGURE 5. Receiver Noise Immunity: No Response at Output Input Waveform.

Typical Application

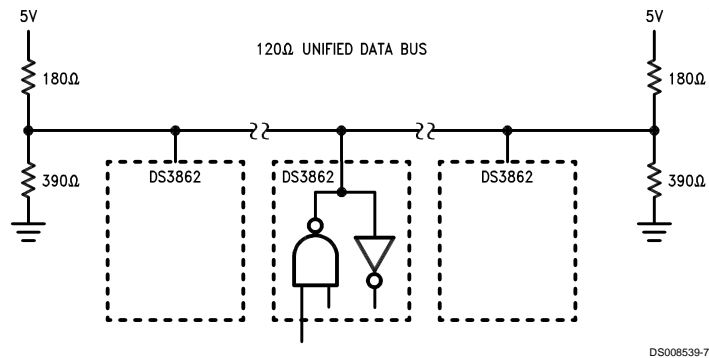

DS008539-7

Physical Dimensions inches (millimeters) unless otherwise noted (Continued)

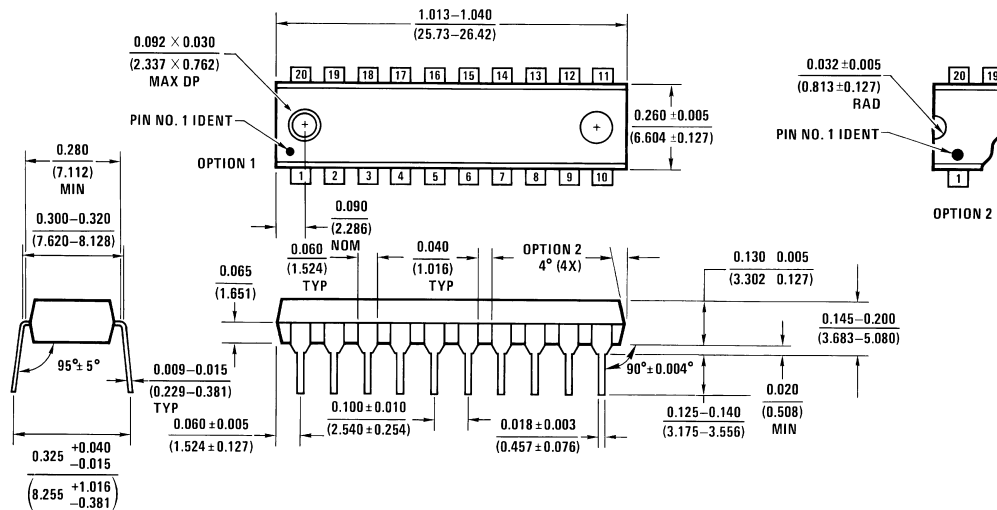

Molded Dual-In-Line Package (N)
Order Number DS3862N
NS Package N20A

N20A (REV G)

LIFE SUPPORT POLICY

NATIONAL'S PRODUCTS ARE NOT AUTHORIZED FOR USE AS CRITICAL COMPONENTS IN LIFE SUPPORT DEVICES OR SYSTEMS WITHOUT THE EXPRESS WRITTEN APPROVAL OF THE PRESIDENT AND GENERAL COUNSEL OF NATIONAL SEMICONDUCTOR CORPORATION. As used herein:

1. Life support devices or systems are devices or systems which, (a) are intended for surgical implant into the body, or (b) support or sustain life, and whose failure to perform when properly used in accordance with instructions for use provided in the labeling, can be reasonably expected to result in a significant injury to the user.
2. A critical component is any component of a life support device or system whose failure to perform can be reasonably expected to cause the failure of the life support device or system, or to affect its safety or effectiveness.

National Semiconductor Corporation
 Americas
 Tel: 1-800-272-9959
 Fax: 1-800-737-7018
 Email: support@nsc.com
 www.national.com

National Semiconductor Europe
 Fax: +49 (0) 1 80-530 85 86
 Email: europe.support@nsc.com
 Deutsch Tel: +49 (0) 1 80-530 85 85
 English Tel: +49 (0) 1 80-532 78 32
 Français Tel: +49 (0) 1 80-532 93 58
 Italiano Tel: +49 (0) 1 80-534 16 80

National Semiconductor Asia Pacific Customer Response Group
 Tel: 65-2544466
 Fax: 65-2504466
 Email: sea.support@nsc.com

National Semiconductor Japan Ltd.
 Tel: 81-3-5639-7560
 Fax: 81-3-5639-7507

This datasheet has been downloaded from:

www.DatasheetCatalog.com

Datasheets for electronic components.

National Semiconductor was acquired by Texas Instruments.

http://www.ti.com/corp/docs/investor_relations/pr_09_23_2011_national_semiconductor.html

This file is the datasheet for the following electronic components:

DS3862J - <http://www.ti.com/product/ds3862j?HQS=TI-null-null-dscatalog-df-pf-null-wwe>

DS3862N - <http://www.ti.com/product/ds3862n?HQS=TI-null-null-dscatalog-df-pf-null-wwe>

DS3862WM - <http://www.ti.com/product/ds3862wm?HQS=TI-null-null-dscatalog-df-pf-null-wwe>



LittleDiode supplies new, hard to find or obsolete electronic components and semiconductors all over the world.

With over two million different components listed you are sure to find the part you need.

Feel free to visit us today at our online store:

LittleDiode.com

Looking forward to providing you with the best possible service.