

## DS8935 LocalTalk™ Dual Driver/Triple Receiver

### General Description

The DS8935 is a dual driver/triple receiver device optimized to provide a single chip solution for a LocalTalk Interface. The device provides one differential TIA/EIA-422 driver, one TIA/EIA-423 single ended driver, one TIA/EIA-422 receiver and two TIA/EIA-423 receivers, all in a surface mount 16-pin package. This device is electrically similar to the 26LS30 and 26LS32 devices.

The drivers feature  $\pm 10V$  common mode range, and the differential driver provides TRI-STATEable outputs. The receivers offer  $\pm 200$  mV thresholds over the  $\pm 10V$  common mode range.

The device offers enable circuitry for the differential driver and selectable enabling for the three receivers.

### Features

- Single chip solution for LocalTalk port
- Two driver/three receivers per package
- Wide common mode range:  $\pm 10V$
- $\pm 200$  mV receiver sensitivity
- 70 mV typical receiver input hysteresis
- Available in SOIC packaging
- Failsafe receiver for open inputs

### Connection Diagram

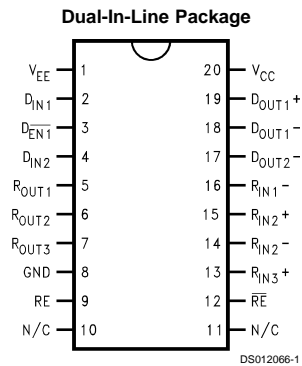

Order Number **DS8935WM**  
See NS Package Number **M20B**

### Functional Diagram

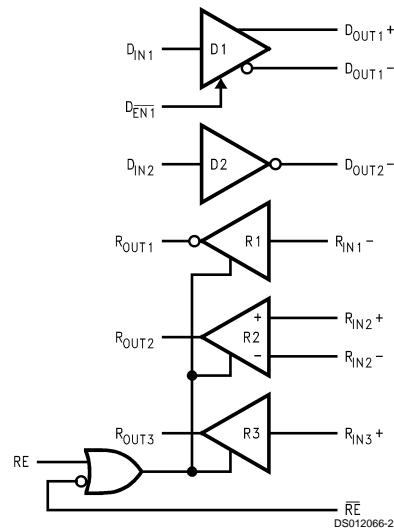

### Absolute Maximum Ratings (Note 1)

If Military/Aerospace specified devices are required, please contact the National Semiconductor Sales Office/Distributors for availability and specifications.

Supply Voltage ( $V_{CC}$ )	+7V
Supply Voltage ( $V_{EE}$ )	-7V
Enable Input Voltage ( $\overline{D_{EN1}}$ , RE, $\overline{RE}$ )	+7V
Driver Input Voltage ( $D_{IN}$ )	+7V
Driver Output Voltage (Power Off: $D_{OUT}$ )	±15V
Receiver Input Voltage ( $V_{ID}$ : $R_{IN+}$ - $R_{IN-}$ )	±25V
Receiver Input Voltage ( $V_{CM}$ : $(R_{IN+} + R_{IN-})/2$ )	±25V
Receiver Input Voltage (Input to GND: $R_{IN}$ )	±25V
Receiver Output Voltage ( $R_{OUT}$ )	+5.5V
Maximum Package Power Dissipation @+25°C	
M Package	1.34W

Derate M Package 10.7 mW/°C above +25°C  
 Storage Temperature Range -65°C to +150°C  
 Lead Temperature Range (Soldering, 4 Sec.) +260°C  
 This device does not meet 2000V ESD Rating (Note 8)

### Recommended Operating Conditions

	Min	Typ	Max	Units
Supply Voltage ( $V_{CC}$ )	+4.75	+5.0	+5.25	V
Supply Voltage ( $V_{EE}$ )	-4.75	-5.0	-5.25	V
Operating Free Air Temperature ( $T_A$ )	0	25	70	°C

### Electrical Characteristics (Notes 2, 3)

Over Supply Voltage and Operating Temperature ranges, unless otherwise specified

Symbol	Parameter	Conditions	Pin	Min	Typ	Max	Units	
<b>DIFFERENTIAL DRIVER CHARACTERISTICS</b>								
$V_{OD}$	Output Differential Voltage	$R_L = \infty$ or $R_L = 3.9\text{ k}\Omega$	D <sub>OUT+</sub> , D <sub>OUT-</sub>	±7	±9.0	±10	V	
$V_O$	Output Voltage	$R_L = \infty$ or $R_L = 3.9\text{ k}\Omega$		±4.5	±5.25		V	
$V_{OD1}$	Output Differential Voltage	$R_L = 100\Omega$ , Figure 1		4.0	6.4		V	
$V_{SS}$	$ V_{OD1} - V_{OD1} $			8.0	12.8		V	
$\Delta V_{OD1}$	Output Unbalance				0.02	0.4	V	
$V_{OS}$	Offset Voltage				0	3	V	
$\Delta V_{OS}$	Offset Unbalance				0.05	0.4	V	
$V_{OD2}$	Output Differential Voltage	$R_L = 140\Omega$ , Figure 1		6.0	7.0		V	
$I_{OZD}$	TRI-STATE® Leakage Current	$V_{CC} = 5.25V$			2	150		µA
		$V_{EE} = -5.25V$			1	100		µA
		$V_O = +10V$		-1	-100		µA	
		$V_O = -10V$		-2	-150		µA	
<b>SINGLE ENDED DRIVER CHARACTERISTICS</b>								
$V_O$	Output Voltage (No Load)	$R_L = \infty$ or $R_L = 3.9\text{ k}\Omega$ , Figure 2	D <sub>OUT-</sub>	4	4.4	6	V	
$V_T$	Output Voltage	$R_L = 3\text{ k}\Omega$ , Figure 2		3.7	4.3		V	
		$R_L = 450\Omega$ , Figure 2		3.6	4.1		V	
$\Delta V_T$	Output Unbalance			0.02	0.4	V		
<b>DRIVER CHARACTERISTICS</b>								
$V_{CM}$	Common Mode Range	Power Off, or D1 Disabled	D <sub>OUT+</sub> , D <sub>OUT-</sub>	±10			V	
$I_{OSD}$	Short Circuit Current	$V_O = 0V$ , Sourcing Current			-80	-150		mA
		$V_O = 0V$ , Sinking Current			80	150		mA
$I_{OXD}$	Power-Off Leakage Current ( $V_{CC} = V_{EE} = 0V$ )	$V_O = +10V$			2	150		µA
		$V_O = +6V$			1	100		µA
		$V_O = -6V$			-1	-100		µA
		$V_O = -10V$			-2	-150		µA

## Electrical Characteristics (Notes 2, 3) (Continued)

Over Supply Voltage and Operating Temperature ranges, unless otherwise specified

Symbol	Parameter	Conditions	Pin	Min	Typ	Max	Units	
<b>RECEIVER CHARACTERISTICS</b>								
$V_{TH}$	Input Threshold	$-7V \leq V_{CM} \leq +7V$	$R_{IN+}$ , $R_{IN-}$	-200	±35	+200	mV	
$V_{HY}$	Hysteresis	$V_{CM} = 0V$			70		mV	
$R_{IN}$	Input Resistance	$-10V \leq V_{CM} \leq +10V$			6.0	8.5	kΩ	
$I_{IN}$	Input Current (Other Input = 0V, Power On, or $V_{CC} = V_{EE} = 0V$ )	$V_{IN} = +10V$					3.25	mA
		$V_{IN} = +3V$			0		1.50	mA
		$V_{IN} = -3V$		0		-1.50	mA	
		$V_{IN} = -10V$				-3.25	mA	
$V_{IB}$	Input Balance Test	$R_S = 500\Omega$ (R2 only)				±400	mV	
$V_{OH}$	High Level Output Voltage	$I_{OH} = -400 \mu A$ , $V_{IN} = +200 mV$	$R_{OUT}$	2.7	4.2		V	
		$I_{OH} = -400 \mu A$ , $V_{IN} = OPEN$		2.7	4.2		V	
$V_{OL}$	Low Level Output Voltage	$I_{OL} = 8.0 mA$ , $V_{IN} = -200 mV$			0.3	0.5	V	
$I_{OSR}$	Short Circuit Current	$V_O = 0V$			-15	-34	-85	mA
$I_{OZR}$	TRI-STATE Output Current	$V_{CC} = Max$		$V_O = 2.4V$		0	+20	μA
			$V_O = 0.4V$		0	-20	μA	

## DEVICE CHARACTERISTICS

$V_{IH}$	High Level Input Voltage		$D_{IN+}$ , $D_{EN1}$ , $RE$ , $RE$	2.0			V	
$V_{IL}$	Low Level Input Voltage					0.8	V	
$I_{IH}$	High Level Input Current	$V_{IN} = 2.4V$				1	40	μA
$I_{IL}$	Low Level Input Current	$V_{IN} = 0.4V$				-10	-200	μA
$V_{CL}$	Input Clamp Voltage	$I_{IN} = -12 mA$					-1.5	V
$I_{CC}$	Power Supply Current	No Load D1 Enabled or Disabled	$V_{CC}$		40	65	mA	
$I_{EE}$			$V_{EE}$		-5	-15	mA	

## Switching Characteristics (Notes 4, 5)

Over Supply Voltage and Operating Temperature Ranges, unless otherwise specified

Symbol	Parameter	Conditions	Min	Typ	Max	Units	
<b>DIFFERENTIAL DRIVER CHARACTERISTICS</b>							
$t_{PHLD}$	Differential Propagation Delay High to Low	$R_L = 100\Omega$ , $C_L = 500 pF$ , (Figures 3, 4) $C_1 = C_2 = 50 pF$	70	134	350	ns	
$t_{PLHD}$	Differential Propagation Delay Low to High		70	141	350	ns	
$t_{SKD}$	Differential Skew $ t_{PHLD} - t_{PLHD} $				7	50	ns
$t_r$	Rise Time	$R_L = 100\Omega$ , $C_L = 500 pF$ (Figures 7, 8)	50	140	300	ns	
$t_f$	Fall Time		50	140	300	ns	
$t_{PHZ}$	Disable Time High to Z			300	600	ns	
$t_{PLZ}$	Disable Time Low to Z			300	600	ns	
$t_{PZH}$	Enable Time Z to High			160	350	ns	
$t_{PZL}$	Enable Time Z to Low		160	350	ns		
<b>SINGLE ENDED DRIVER CHARACTERISTICS</b>							
$t_{PHL}$	Propagation Delay High to Low	$R_L = 450\Omega$ , $C_L = 500 pF$ (Figures 5, 6)	70	120	350	ns	
$t_{PLH}$	Propagation Delay Low to High		70	150	350	ns	
$t_{SK}$	Skew, $ t_{PHL} - t_{PLH} $				30	70	ns
$t_r$	Rise Time		50	100	300	ns	
$t_f$	Fall Time		20	50	300	ns	
<b>RECEIVER CHARACTERISTICS</b>							
$t_{PHL}$	Propagation Delay High to Low	$C_L = 15 pF$ (Figures 9, 10)	10	33	75	ns	
$t_{PLH}$	Propagation Delay Low to High		10	30	75	ns	
$t_{SK}$	Skew, $ t_{PHL} - t_{PLH} $				3	20	ns

## Switching Characteristics (Notes 4, 5) (Continued)

Over Supply Voltage and Operating Temperature Ranges, unless otherwise specified

Symbol	Parameter	Conditions	Min	Typ	Max	Units
<b>RECEIVER CHARACTERISTICS</b>						
$t_{HZ}$	Disable Time High to Z	$C_L = 15 \text{ pF}$ (Figures 9, 11)		20	75	ns
$t_{LZ}$	Disable Time Low to Z			20	75	ns
$t_{ZH}$	Enable Time Z to High			20	75	ns
$t_{ZL}$	Enable Time Z to Low			20	75	ns

**Note 1:** Absolute Maximum Ratings are those values beyond which the safety of the device cannot be guaranteed. They are not meant to imply that the devices should be operated at these limits. The table of Electrical Characteristics specifies conditions of device operation.

**Note 2:** Current into device pins is defined as positive. Current out of device pins is defined as negative. All voltages are referenced to ground except  $V_{OD}$ ,  $V_{OD1}$ ,  $V_{OD2}$ , and  $V_{SS}$ .

**Note 3:** All typicals are given for:  $V_{CC} = +5.0\text{V}$ ,  $V_{EE} = -5.0\text{V}$ ,  $T_A = +25^\circ\text{C}$  unless otherwise specified.

## Truth Tables

### Driver (D1)

Inputs		Outputs	
$\overline{D_{EN1}}$	$D_{IN1}$	$D_{OUT1+}$	$D_{OUT1-}$
H	X	Z	Z
L	L	L	H
L	H	H	L

### Driver (D2)

Input	Output
$D_{IN2}$	$D_{OUT2-}$
L	H
H	L

### Receiver (1)

RE	$\overline{RE}$	Input	Output
		$R_{IN1-}$	$R_{OUT1}$
0	1	X	Z
Any Other Combination		$\leq -200 \text{ mV}$	H
		$\geq +200 \text{ mV}$	L
		Open <sup>†</sup>	H

### Receiver (2)

RE	$\overline{RE}$	Inputs	Output
		$R_{IN2+}-R_{IN2-}$	$R_{OUT2}$
0	1	X	Z
Any Other Combination		$\leq -200 \text{ mV}$	L
		$\geq +200 \text{ mV}$	H
		Open <sup>†</sup>	H

### Receiver (3)

RE	$\overline{RE}$	Input	Output
		$R_{IN3+}$	$R_{OUT3}$
0	1	X	Z
Any Other Combination		$\leq -200 \text{ mV}$	L
		$\geq +200 \text{ mV}$	H
		Open <sup>†</sup>	H

H = Logic High Level (Steady State)

L = Logic Low Level (Steady State)

X = Irrelevant (Any Input)

Z = Off State (TRI-STATE, High Impedance)

<sup>†</sup>OPEN = Non-Terminated

## Parameter Measurement Information

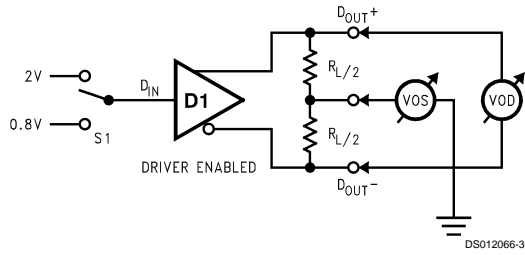

FIGURE 1. Differential Driver DC Test Circuit

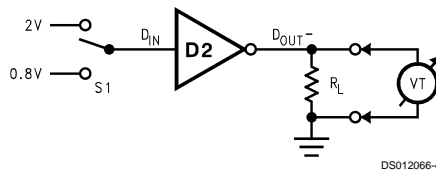

FIGURE 2. Single Ended Driver DC Test Circuit

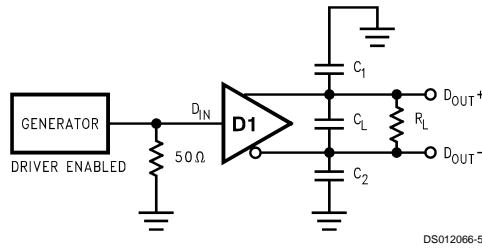

FIGURE 3. Differential Driver Propagation Delay and Transition Time Test Circuit

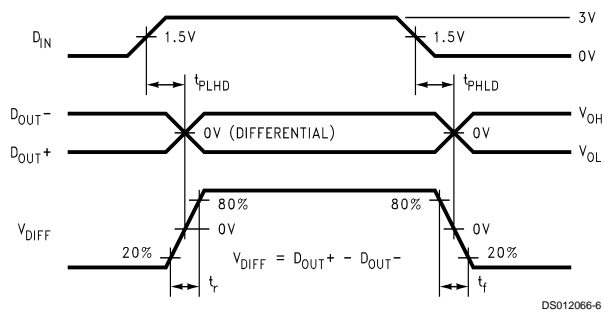

FIGURE 4. Differential Driver Propagation Delay and Transition Time Waveforms

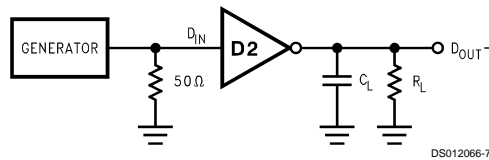

FIGURE 5. Single Ended Driver Propagation Delay and Transition Time Test Circuit

## Parameter Measurement Information (Continued)

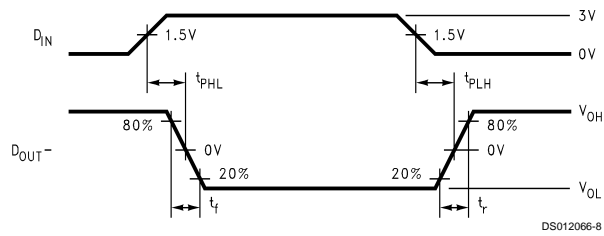

FIGURE 6. Single Ended Driver Propagation Delay and Transition Time Waveform

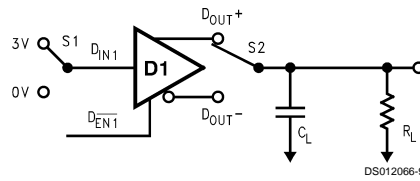

FIGURE 7. Differential Driver TRI-STATE Test Circuit

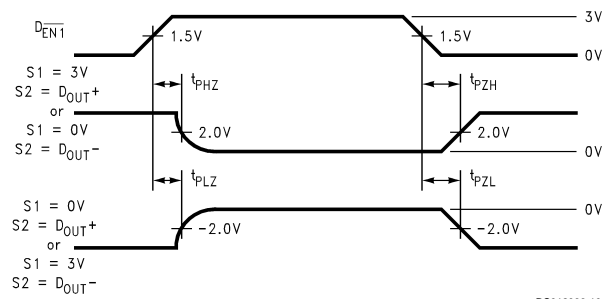

FIGURE 8. Differential Driver TRI-STATE Waveforms

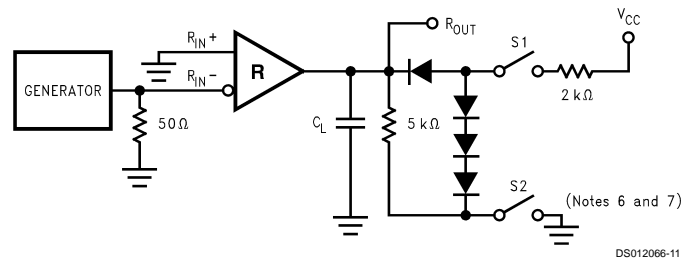

FIGURE 9. Receiver Propagation Delay Test Circuit

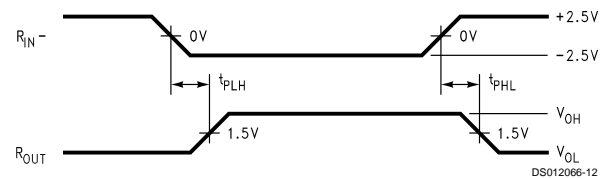
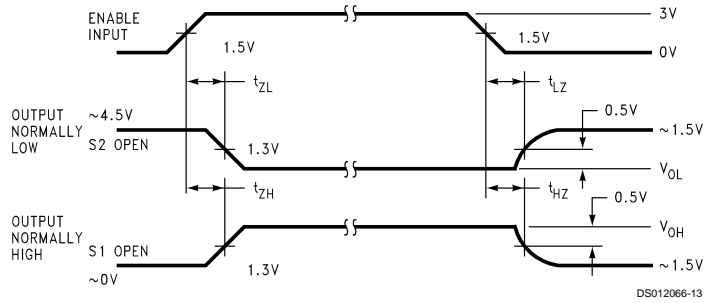

FIGURE 10. Receiver Propagation Delay Waveform

## Parameter Measurement Information (Continued)



**FIGURE 11. Receiver TRI-STATE Delay Waveform**

**Note 4:** Generator waveform for all tests unless otherwise specified:  $f = 500 \text{ kHz}$ ,  $Z_O = 50\Omega$ ,  $t_r \leq 10 \text{ ns}$ ,  $t_f \leq 10 \text{ ns}$ .

**Note 5:**  $C_L$  includes probe and jig capacitance.

**Note 6:** All diodes are 1N916 or equivalent.

**Note 7:** S1 and S2 closed except where shown.

**Note 8:** ESD Rating HBM (1.5 k $\Omega$ , 100 pF) pins 14, 16  $\geq 1500\text{V}$ , all other pins  $\geq 2000\text{V}$ .

## Typical Application Information

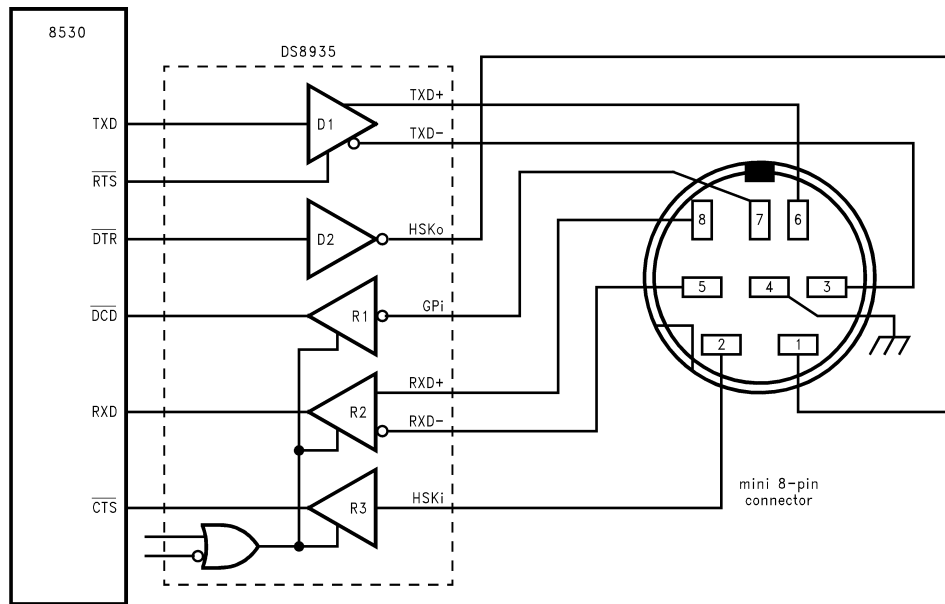

**FIGURE 12. Typical LocalTalk Application**

DS012066-14

## Typical Application Information (Continued)

TABLE 1. Device Pin Descriptions

Pin#	Name	Description
2, 4	$D_{IN}$	TTL Driver Input Pins
3	$\overline{D}_{EN1}$	Active Low Driver Enable Pin. A High on this Pin TRI-STATES the Driver Outputs (D1 Only)
19	$D_{OUT+}$	Non-Inverting Driver Output Pin
17, 18	$D_{OUT-}$	Inverting Driver Output Pin
13, 15	$R_{IN+}$	Non-Inverting Receiver Input Pin
16, 14	$R_{IN-}$	Inverting Receiver Input Pin
5, 6, 7	$R_{OUT}$	Receiver Output Pin
9	$R_{EN}$	Active Low Receiver Enable
12	$\overline{R}_{EN}$	Active High Receiver Enable
10, 11	N/C	Not Connected
8	GND	Ground Pin
1	$V_{EE}$	Negative Power Supply Pin, $-5V \pm 5\%$
20	$V_{CC}$	Positive Power Supply Pin, $+5V \pm 5\%$

### DRIVER OUTPUT WAVEFORMS

The driver configuration on the DS8935 is unique among TIA/EIA-422 devices in that it utilizes  $-5V V_{EE}$  supply. A typical TIA/EIA-422 driver uses  $+5V$  only and generates signal swings of approximately  $0V-5V$ .

By utilizing  $V_{EE}$ , the differential driver is able to generate a much larger differential signal. The typical output voltage is about  $|4| V$ , which gives  $|8| V$  differentially, thus providing a

much greater noise margin than  $+5V$  drivers. See Figure 13. The receiver therefore has a range of  $+8V$  to  $-8V$  or  $V_{SS}$  of  $16V$  ( $V_{SS} = V_{OD} - V_{OD}$ ).

Each side of the differential driver operates similar to a TIA/EIA-423 driver. The output voltages are slightly different due to the loading: the differential driver has differential termination, the single-ended driver is terminated with a resistor to ground.

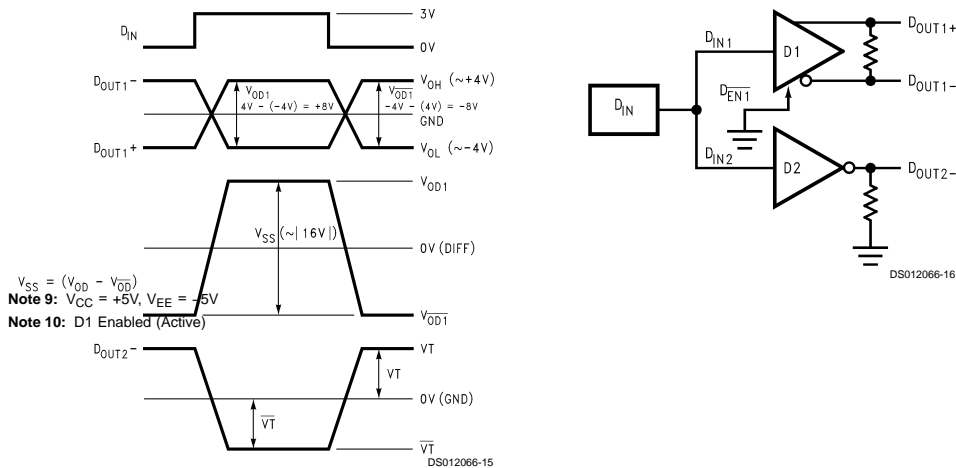

FIGURE 13. Typical Driver Output Waveforms

## Typical Application Information

(Continued)

### UNUSED PINS

Unused driver outputs should be left open. If tied to either ground or supply, the driver may enter an  $I_{OS}$  state and consume excessive power. Unused driver inputs should not be left floating as this may lead to unwanted switching which may affect  $I_{CC}$ , particularly the frequency component. Unused driver inputs should be tied to ground.

Receiver outputs will be in a HIGH state when inputs are open; therefore, outputs should not be tied to ground. It is best to leave unused receiver outputs floating.

### RECEIVER FAILSAFE

All three receivers on this device incorporate open input fail-safe protection. The differential receiver output will be in a HIGH state when inputs are open, but will be indetermined if inputs are shorted together. Unused differential inputs should be left floating.

Both single-ended receivers (inverting and non-inverting) are biased internally so that an open input will result in a HIGH output. Therefore, these inputs should not be shorted to ground when unused.

### BYPASS CAPACITORS

Bypass capacitors are recommended for both  $V_{CC}$  and  $V_{EE}$ . Noise induced on the supply lines can affect the signal quality of the output;  $V_{CC}$  affects the  $V_{OH}$  and  $V_{EE}$  affects the  $V_{OL}$ . Capacitors help reduce the effect on signal quality. A value of 0.1  $\mu\text{F}$  is typically used.

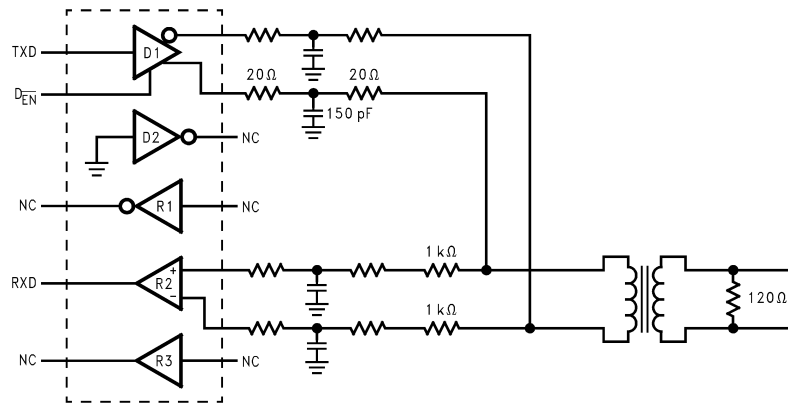

FIGURE 14. Differential Communication, Transformer-Coupled to a Twisted-Pair Line

### SINGLE +5V SUPPLY

The DS8935 is derived from the DS3691/92 which could be configured using a single +5V supply ( $V_{EE} = 0\text{V}$ ). This device is not specified for this type of operation. However, the device will not be damaged if operated using a single +5V supply.

Both drivers require the  $-5\text{V}$  supply in order to meet the output voltage levels specified. When the device switches from a positive voltage to the complimentary state, it is pulled toward the  $V_{EE}$  level. If that level is  $0\text{V}$ , then the complimentary

state will be near  $0\text{V}$  instead of  $V_{EE}$ . Thus, the output would switch from about  $4\text{V}$  to  $0\text{V}$ , instead of  $4\text{V}$  to  $-4\text{V}$ . The differential driver will meet TIA/EIA-422, but with a reduced noise margin. The single-ended driver will not meet TIA/EIA-423 without the  $-5\text{V}$  supply.

### TERMINATION

On a multi-point transmission line which is electrically long, it is advisable to terminate the line at both ends with its characteristic impedance to prevent signal reflection and its associated noise/crosstalk.

A  $100\Omega$  termination resistor is commonly specified by TIA/EIA-422 for differential signals. The DS8935 is also specified using  $140\Omega$  termination which will result in less power associated with the driver output. The additional resistance is typical of applications requiring EMI filtering on the driver outputs.

### TWO-WIRE LocalTalk

The DS8935 is a single chip solution for a LocalTalk interface. A typical application is shown in Figure 12.

An alternative implementation of LocalTalk is to only use two wires to communicate. The differential data lines can be transformer-coupled on to a twisted pair medium. See Figure 14. The handshake function must then be accomplished in software.

## Typical Application Information (Continued)

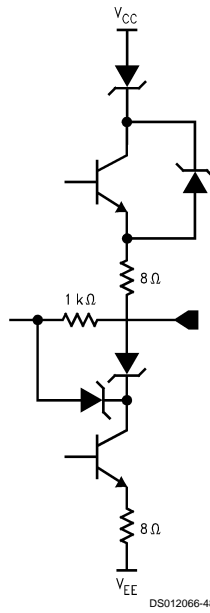

FIGURE 15. Driver Output Structure

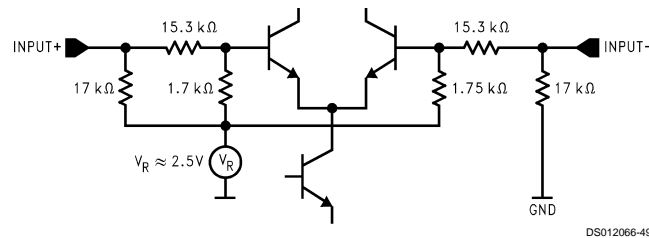

FIGURE 16. Receiver Input Structure

## Typical Performance Characteristics

The DS8935 is very closely related to the DS8925. Please refer to the DS8925 datasheet for the typical performance characteristics.



**Physical Dimensions** inches (millimeters) unless otherwise noted

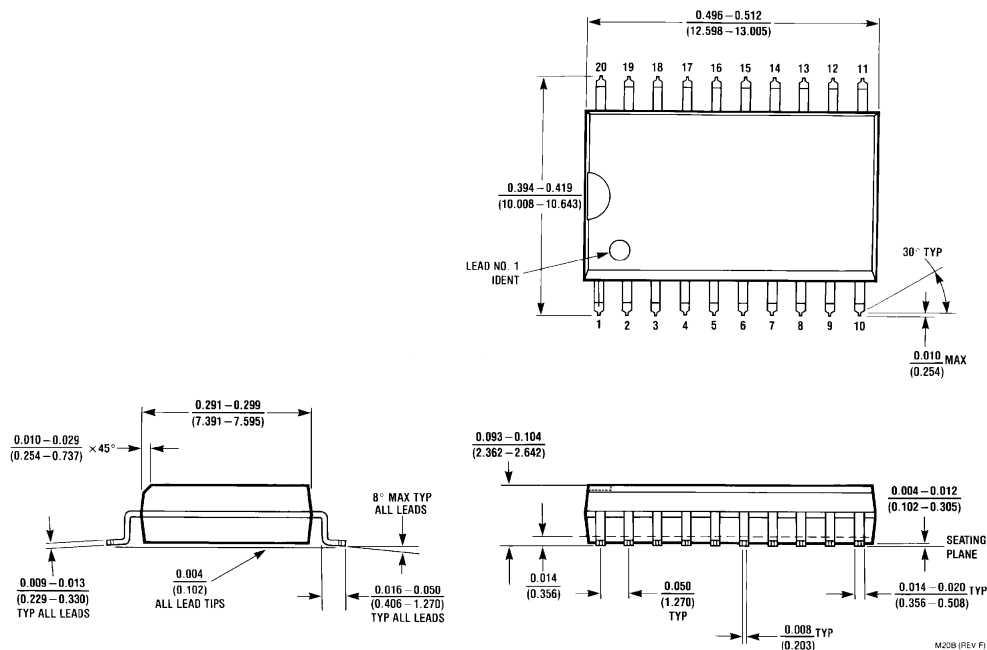

**20-Lead (0.300" Wide) Molded Small Outline Package, JEDEC  
Order Number DS8935WM  
NS Package Number M20B**

**LIFE SUPPORT POLICY**

NATIONAL'S PRODUCTS ARE NOT AUTHORIZED FOR USE AS CRITICAL COMPONENTS IN LIFE SUPPORT DEVICES OR SYSTEMS WITHOUT THE EXPRESS WRITTEN APPROVAL OF THE PRESIDENT OF NATIONAL SEMICONDUCTOR CORPORATION. As used herein:

- Life support devices or systems are devices or systems which, (a) are intended for surgical implant into the body, or (b) support or sustain life, and whose failure to perform when properly used in accordance with instructions for use provided in the labeling, can be reasonably expected to result in a significant injury to the user.
- A critical component in any component of a life support device or system whose failure to perform can be reasonably expected to cause the failure of the life support device or system, or to affect its safety or effectiveness.



**National Semiconductor Corporation**  
Americas  
Tel: 1-800-272-9959  
Fax: 1-800-737-7018  
Email: support@nsc.com

**National Semiconductor Europe**  
Fax: +49 (0) 1 80-530 85 86  
Email: europe.support@nsc.com  
Deutsch Tel: +49 (0) 1 80-530 85 85  
English Tel: +49 (0) 1 80-532 78 32  
Français Tel: +49 (0) 1 80-532 93 58  
Italiano Tel: +49 (0) 1 80-534 16 80

**National Semiconductor Asia Pacific Customer Response Group**  
Tel: 65-2544466  
Fax: 65-2504466  
Email: sea.support@nsc.com

**National Semiconductor Japan Ltd.**  
Tel: 81-3-5620-6175  
Fax: 81-3-5620-6179

www.national.com

This datasheet has been downloaded from:

[www.DatasheetCatalog.com](http://www.DatasheetCatalog.com)

Datasheets for electronic components.

# National Semiconductor was acquired by Texas Instruments.

[http://www.ti.com/corp/docs/investor\\_relations/pr\\_09\\_23\\_2011\\_national\\_semiconductor.html](http://www.ti.com/corp/docs/investor_relations/pr_09_23_2011_national_semiconductor.html)

This file is the datasheet for the following electronic components:

DS8935WM - <http://www.ti.com/product/ds8935wm?HQS=TI-null-null-dscatalog-df-pf-null-ww>



LittleDiode supplies new, hard to find or obsolete electronic components and semiconductors all over the world.

With over two million different components listed you are sure to find the part you need.

Feel free to visit us today at our online store:

[LittleDiode.com](http://LittleDiode.com)

Looking forward to providing you with the best possible service.