

DS90CF386/DS90CF366

+3.3V LVDS Receiver 24-Bit Flat Panel Display (FPD) Link—85 MHz, +3.3V LVDS Receiver 18-Bit Flat Panel Display (FPD) Link—85 MHz

General Description

The DS90CF386 receiver converts the four LVDS data streams (Up to 2.38 Gbps throughput or 297.5 Megabytes/sec bandwidth) back into parallel 28 bits of CMOS/TTL data (24 bits of RGB and 4 bits of Hsync, Vsync, DE and CNTL). Also available is the DS90CF366 that converts the three LVDS data streams (Up to 1.78 Gbps throughput or 223 Megabytes/sec bandwidth) back into parallel 21 bits of CMOS/TTL data (18 bits of RGB and 3 bits of Hsync, Vsync and DE). Both Receivers' outputs are Falling edge strobe. A Rising edge or Falling edge strobe transmitter (DS90C385/DS90C365) will interoperate with a Falling edge strobe Receiver without any translation logic.

The DS90CF386 is also offered in a 64 ball, 0.8mm fine pitch ball grid array (FBGA) package which provides a 44 % reduction in PCB footprint compared to the 56L TSSOP package.

This chipset is an ideal means to solve EMI and cable size problems associated with wide, high speed TTL interfaces.

Features

- 20 to 85 MHz shift clock support
- Rx power consumption <142 mW (typ) @85MHz Grayscale
- Rx Power-down mode <1.44 mW (max)
- ESD rating >7 kV (HBM), >700V (EIAJ)
- Supports VGA, SVGA, XGA and Single Pixel SXGA.
- PLL requires no external components
- Compatible with TIA/EIA-644 LVDS standard
- Low profile 56-lead or 48-lead TSSOP package
- DS90CF386 also available in a 64 ball, 0.8mm fine pitch ball grid array (FBGA) package

Block Diagrams

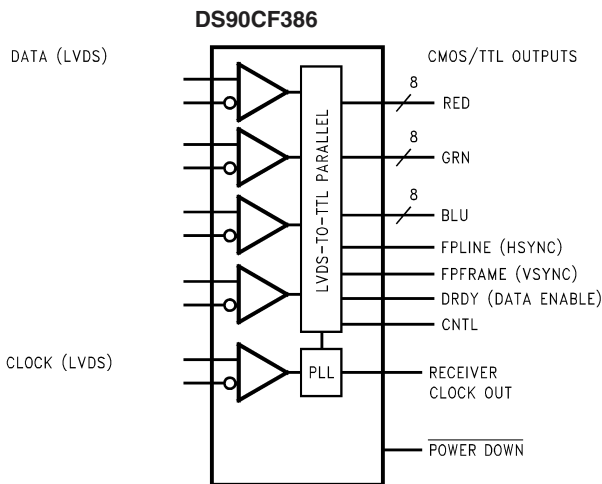

Order Number DS90CF386MTD or DS90CF386SLC
See NS Package Number MTD56 or SLC64A

10108527

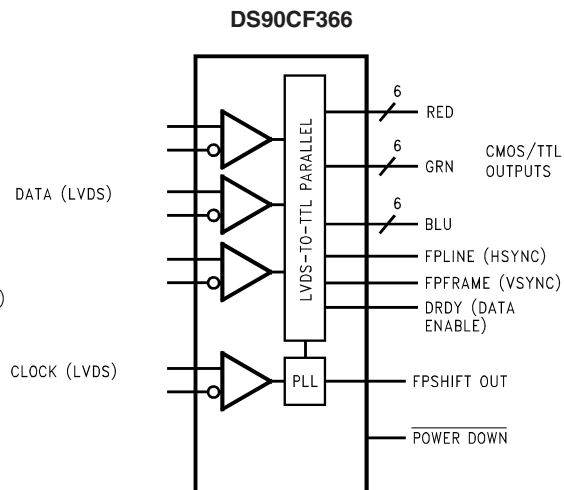

Order Number DS90CF366MTD
See NS Package Number MTD48

10108528

Absolute Maximum Ratings (Note 1)

If Military/Aerospace specified devices are required, please contact the National Semiconductor Sales Office/Distributors for availability and specifications.

Supply Voltage (V_{CC})	-0.3V to +4V
CMOS/TTL Output Voltage	-0.3V to ($V_{CC} + 0.3V$)
LVDS Receiver Input Voltage	-0.3V to ($V_{CC} + 0.3V$)
Junction Temperature	+150°C
Storage Temperature	-65°C to +150°C
Lead Temperature	
(Soldering, 4 sec for TSSOP)	+260°C
Solder Reflow Temperature	
(Soldering, 20 sec for FBGA)	+220°C
Maximum Package Power	
Dissipation Capacity @ 25°C	
MTD56 (TSSOP) Package:	
DS90CF386MTD	1.61 W
MTD48 (TSSOP) Package:	
DS90CF366MTD	1.89 W
Package Derating:	
DS90CF386MTD	12.4 mW/°C above +25°C

DS90CF366MTD	15 mW/°C above +25°C
Maximum Package Power	
Dissipation Capacity @ 25°C	
SLC64A Package:	
DS90CF386SLC	2.0 W
Package Derating:	
DS90CF386SLC	10.2 mW/°C above +25°C
ESD Rating	
(HBM, 1.5 k Ω , 100 pF)	> 7 kV
(EIAJ, 0 Ω , 200 pF)	> 700V

Recommended Operating Conditions

	Min	Nom	Max	Units
Supply Voltage (V_{CC})	3.0	3.3	3.6	V
Operating Free Air Temperature (T_A)	-10	+25	+70	°C
Receiver Input Range	0		2.4	V
Supply Noise Voltage (V_{CC})			100	mV _{PP}

Electrical Characteristics

Over recommended operating supply and temperature ranges unless otherwise specified.

Symbol	Parameter	Conditions	Min	Typ	Max	Units	
CMOS/TTL DC SPECIFICATIONS							
V_{IH}	High Level Input Voltage		2.0		V_{CC}	V	
V_{IL}	Low Level Input Voltage		GND		0.8	V	
V_{OH}	High Level Output Voltage	$I_{OH} = -0.4$ mA	2.7	3.3		V	
V_{OL}	Low Level Output Voltage	$I_{OL} = 2$ mA		0.06	0.3	V	
V_{CL}	Input Clamp Voltage	$I_{CL} = -18$ mA		-0.79	-1.5	V	
I_{IN}	Input Current	$V_{IN} = 0.4V, 2.5V$ or V_{CC}		+1.8	+15	μ A	
		$V_{IN} = GND$	-10	0		μ A	
I_{OS}	Output Short Circuit Current	$V_{OUT} = 0V$		-60	-120	mA	
LVDS RECEIVER DC SPECIFICATIONS							
V_{TH}	Differential Input High Threshold	$V_{CM} = +1.2V$			+100	mV	
V_{TL}	Differential Input Low Threshold		-100			mV	
I_{IN}	Input Current	$V_{IN} = +2.4V, V_{CC} = 3.6V$			± 10	μ A	
		$V_{IN} = 0V, V_{CC} = 3.6V$			± 10	μ A	
RECEIVER SUPPLY CURRENT							
ICCRW	Receiver Supply Current Worst Case	$C_L = 8$ pF, Worst Case Pattern, DS90CF386 (Figures 1, 4)	f = 32.5 MHz		49	70	mA
			f = 37.5 MHz		53	75	mA
			f = 65 MHz		81	114	mA
			f = 85 MHz		96	135	mA
ICCRW	Receiver Supply Current Worst Case	$C_L = 8$ pF, Worst Case Pattern, DS90CF366 (Figures 1, 4)	f = 32.5 MHz		49	60	mA
			f = 37.5 MHz		53	65	mA
			f = 65 MHz		78	100	mA
			f = 85 MHz		90	115	mA
ICCRG	Receiver Supply Current, 16 Grayscale	$C_L = 8$ pF, 16 Grayscale Pattern,	f = 32.5 MHz		28	45	mA
			f = 37.5 MHz		30	47	mA

Electrical Characteristics (Continued)

Over recommended operating supply and temperature ranges unless otherwise specified.

Symbol	Parameter	Conditions	Min	Typ	Max	Units
RECEIVER SUPPLY CURRENT						
		(Figures 2, 3, 4)	f = 65 MHz	43	60	mA
			f = 85 MHz	43	70	mA
ICCRZ	Receiver Supply Current Power Down	Power Down = Low Receiver Outputs Stay Low during Power Down Mode		140	400	μA

Note 1: “Absolute Maximum Ratings” are those values beyond which the safety of the device cannot be guaranteed. They are not meant to imply that the device should be operated at these limits. The tables of “Electrical Characteristics” specify conditions for device operation.

Note 2: Typical values are given for $V_{CC} = 3.3V$ and $T_A = +25C$.

Note 3: Current into device pins is defined as positive. Current out of device pins is defined as negative. Voltages are referenced to ground unless otherwise specified (except V_{OD} and ΔV_{OD}).

Receiver Switching Characteristics

Over recommended operating supply and temperature ranges unless otherwise specified

Symbol	Parameter	Min	Typ	Max	Units	
CLHT	CMOS/TTL Low-to-High Transition Time (Figure 4)		2.0	3.5	ns	
CHLT	CMOS/TTL High-to-Low Transition Time (Figure 4)		1.8	3.5	ns	
RSPos0	Receiver Input Strobe Position for Bit 0 (Figure 11, Figure 12)	f = 85 MHz	0.49	0.84	1.19	ns
RSPos1	Receiver Input Strobe Position for Bit 1		2.17	2.52	2.87	ns
RSPos2	Receiver Input Strobe Position for Bit 2		3.85	4.20	4.55	ns
RSPos3	Receiver Input Strobe Position for Bit 3		5.53	5.88	6.23	ns
RSPos4	Receiver Input Strobe Position for Bit 4		7.21	7.56	7.91	ns
RSPos5	Receiver Input Strobe Position for Bit 5		8.89	9.24	9.59	ns
RSPos6	Receiver Input Strobe Position for Bit 6		10.57	10.92	11.27	ns
RSKM	RxIN Skew Margin (Note 4) (Figure 13)	f = 85 MHz	290			ps
RCOP	RxCLK OUT Period (Figure 5)		11.76	T	50	ns
RCOH	RxCLK OUT High Time (Figure 5)	f = 85 MHz	4.5	5	7	ns
RCOL	RxCLK OUT Low Time (Figure 5)		4.0	5	6.5	ns
RSRC	RxOUT Setup to RxCLK OUT (Figure 5)		2.0			ns
RHRC	RxOUT Hold to RxCLK OUT (Figure 5)		3.5			ns
RCCD	RxCLK IN to RxCLK OUT Delay @ 25°C, $V_{CC} = 3.3V$ (Figure 6)		5.5	7.0	9.5	ns
RPLLS	Receiver Phase Lock Loop Set (Figure 7)				10	ms
RPDD	Receiver Power Down Delay (Figure 10)				1	μs

Note 4: Receiver Skew Margin is defined as the valid data sampling region at the receiver inputs. This margin takes into account the transmitter pulse positions (min and max) and the receiver input setup and hold time (internal data sampling window - RSPos). This margin allows for LVDS interconnect skew, inter-symbol interference (both dependent on type/length of cable), and clock jitter (less than 150 ps).

AC Timing Diagrams

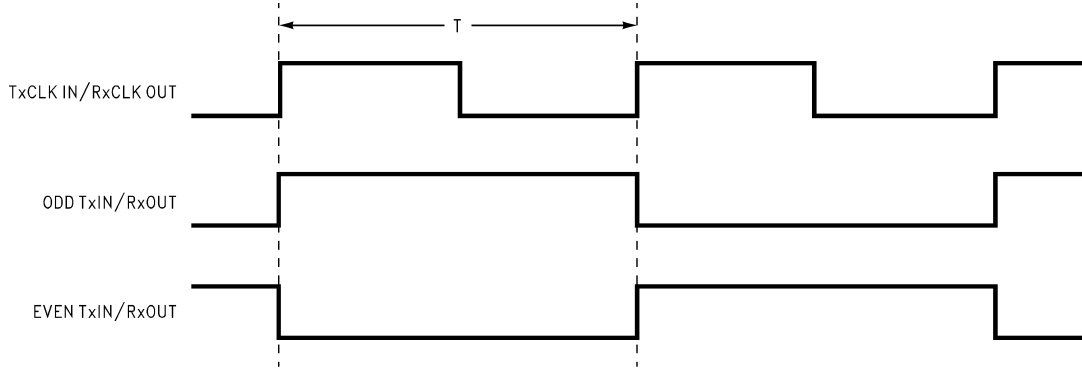

10108502

FIGURE 1. "Worst Case" Test Pattern

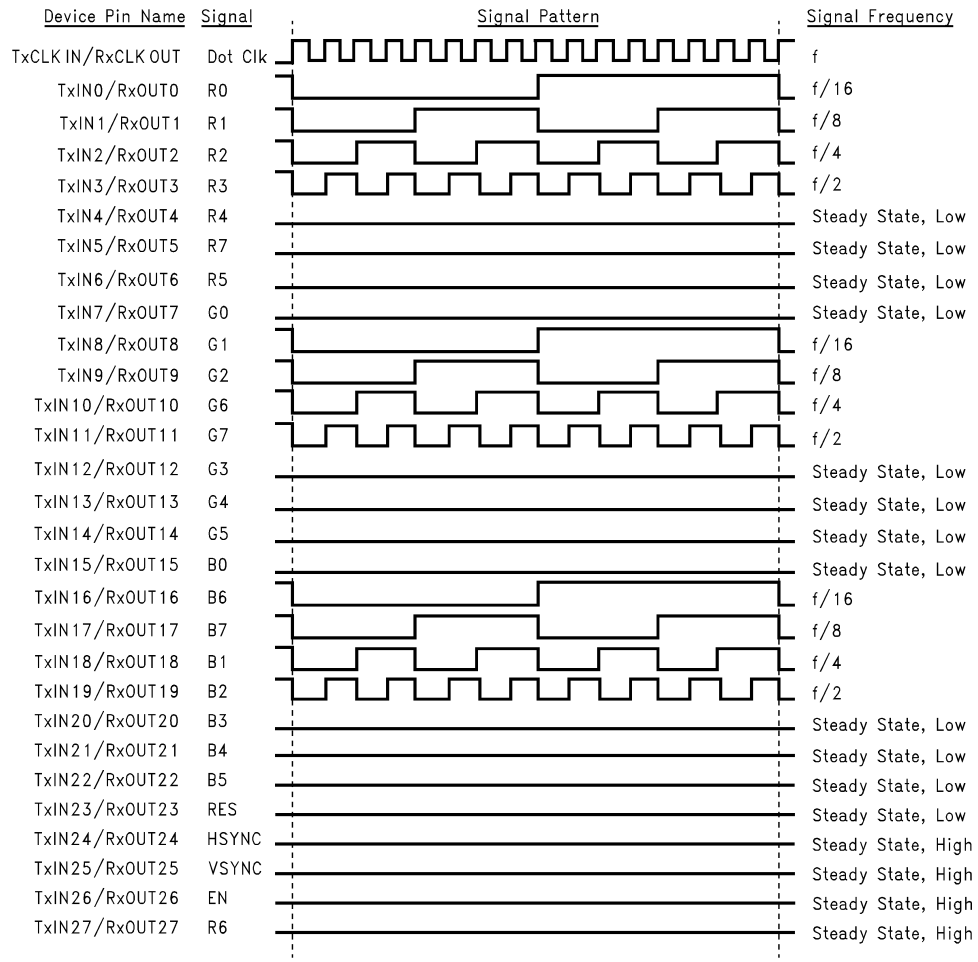

10108512

FIGURE 2. "16 Grayscale" Test Pattern (DS90CF386)(Notes 5, 6, 7, 8)

AC Timing Diagrams (Continued)

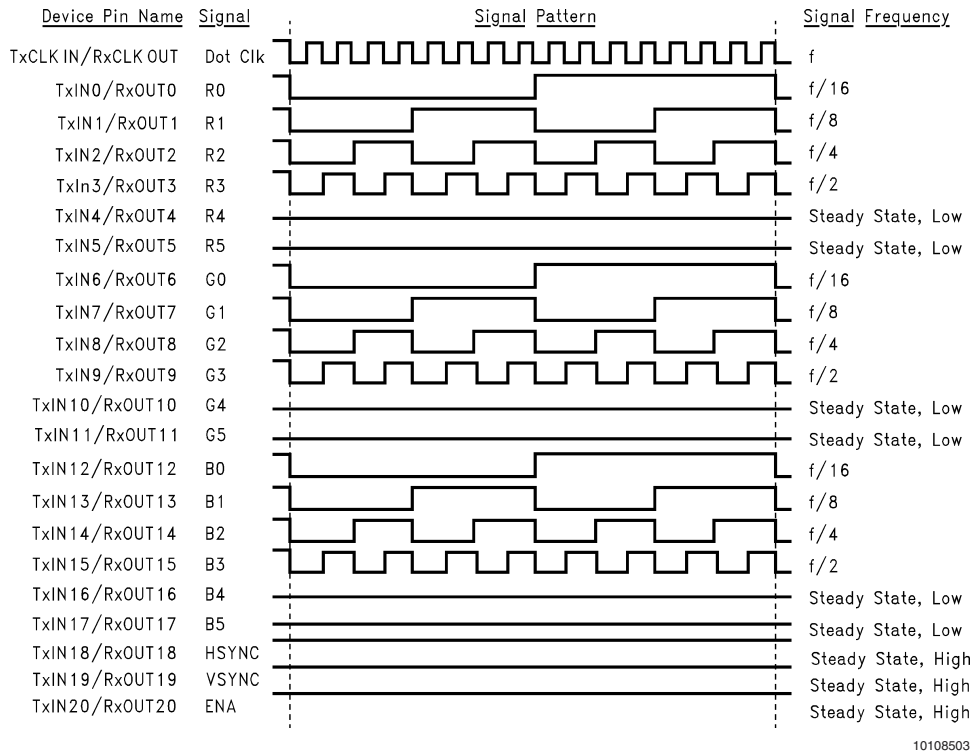

FIGURE 3. "16 Grayscale" Test Pattern (DS90CF366)(Notes 5, 6, 7, 8)

Note 5: The worst case test pattern produces a maximum toggling of digital circuits, LVDS I/O and CMOS/TTL I/O.

Note 6: The 16 grayscale test pattern tests device power consumption for a "typical" LCD display pattern. The test pattern approximates signal switching needed to produce groups of 16 vertical stripes across the display.

Note 7: Figures 1, 3 show a falling edge data strobe (TxCLK IN/RxCLK OUT).

Note 8: Recommended pin to signal mapping. Customer may choose to define differently.

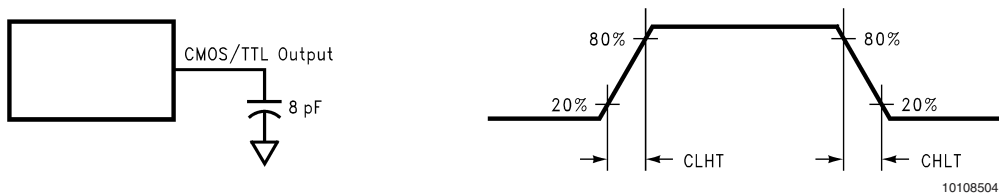

FIGURE 4. DS90CF386/DS90CF366 (Receiver) CMOS/TTL Output Load and Transition Times

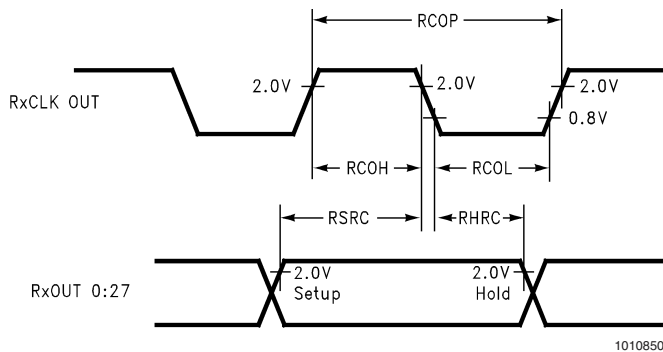

FIGURE 5. DS90CF386/DS90CF366 (Receiver) Setup/Hold and High/Low Times

AC Timing Diagrams (Continued)

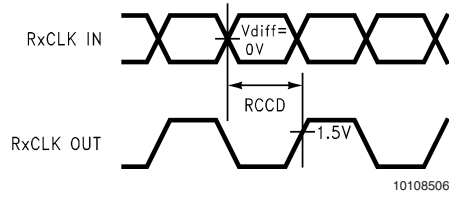

FIGURE 6. DS90CF386/DS90CF366 (Receiver) Clock In to Clock Out Delay

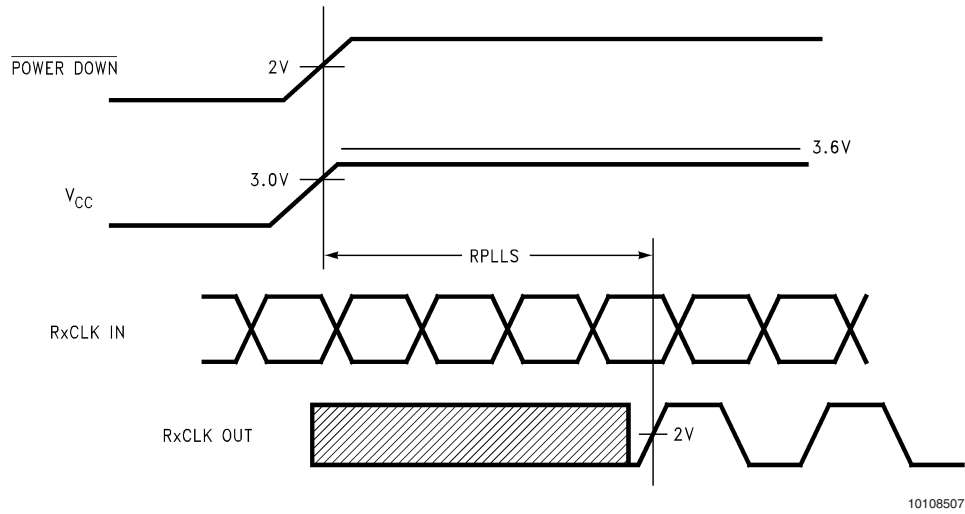

FIGURE 7. DS90CF386/DS90CF366 (Receiver) Phase Lock Loop Set Time

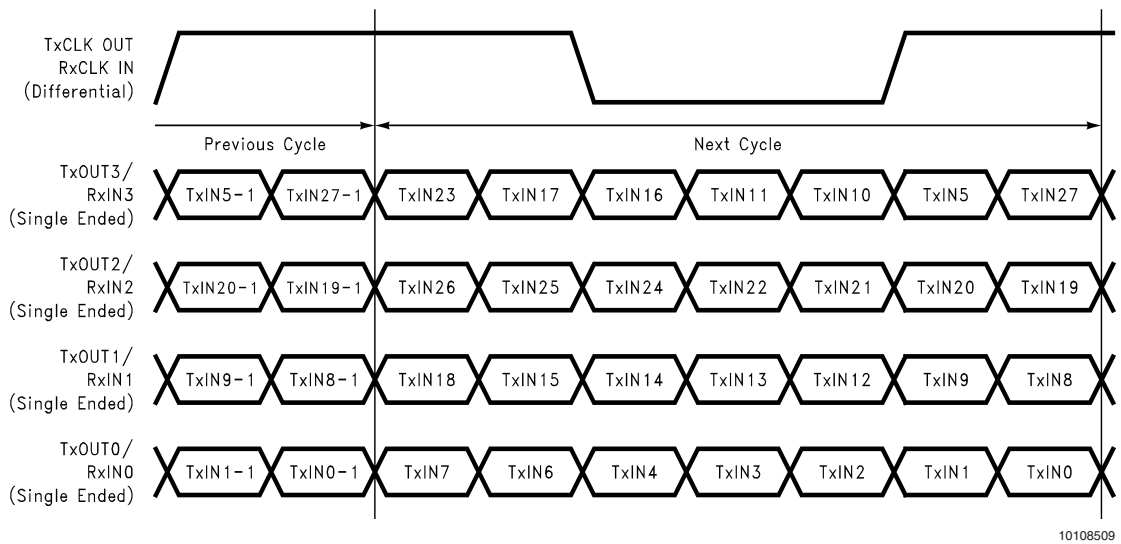

FIGURE 8. 28 Parallel TTL Data Inputs Mapped to LVDS Outputs - DS90CF386

AC Timing Diagrams (Continued)

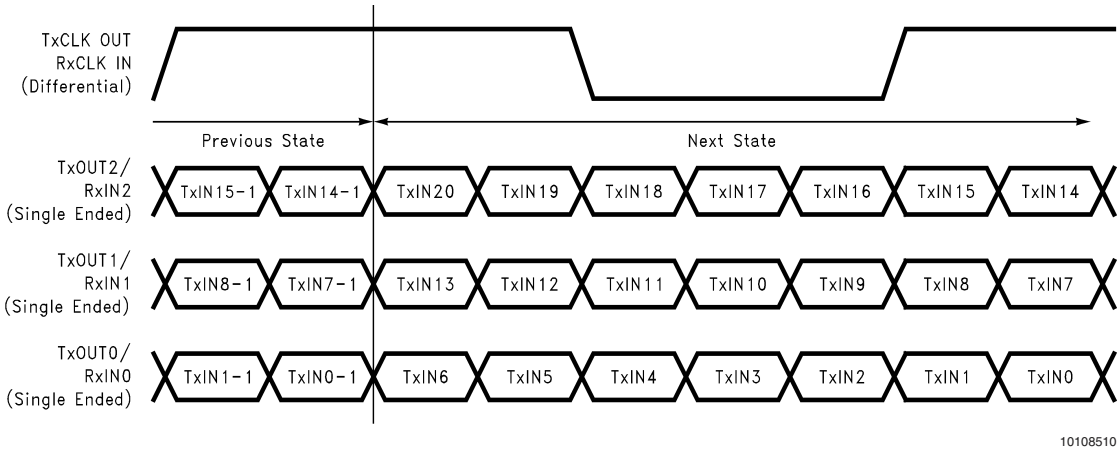

FIGURE 9. 21 Parallel TTL Data Inputs Mapped to LVDS Outputs - DS90CF366

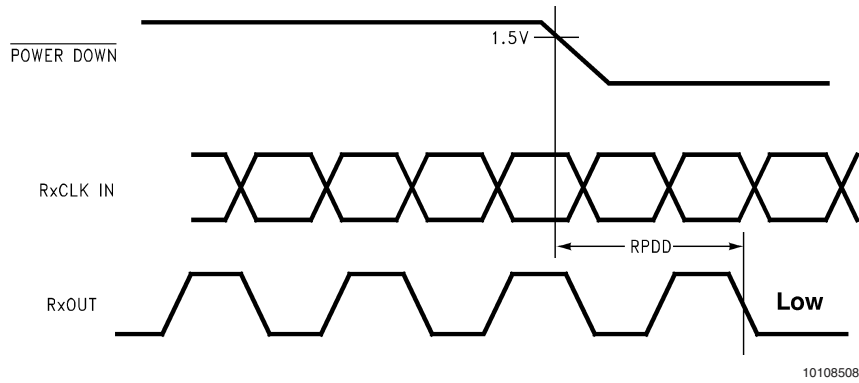
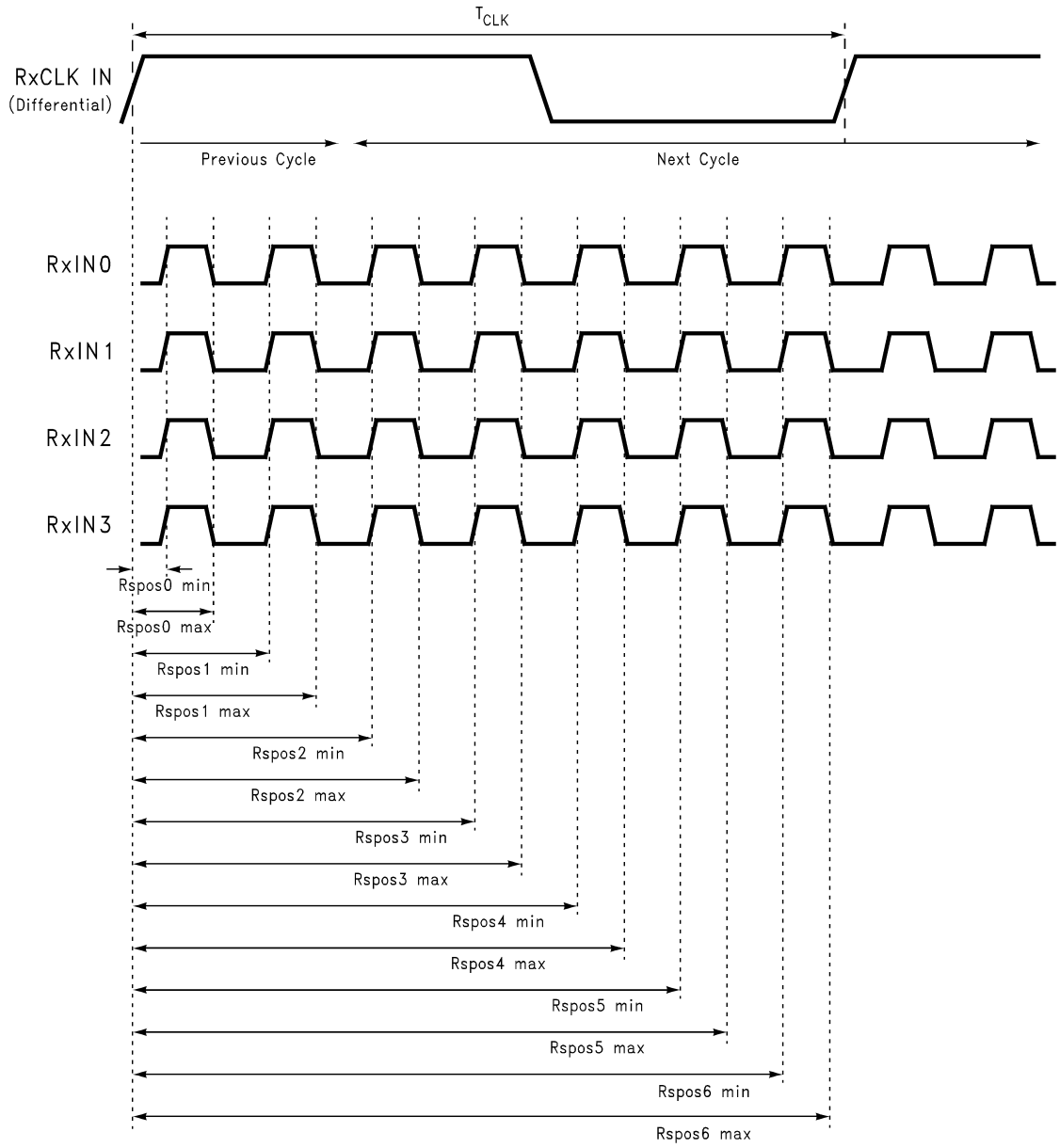

FIGURE 10. DS90CF386/DS90CF366 (Receiver) Power Down Delay

AC Timing Diagrams (Continued)



10108525

FIGURE 11. DS90CF386 (Receiver) LVDS Input Strobe Position

AC Timing Diagrams (Continued)

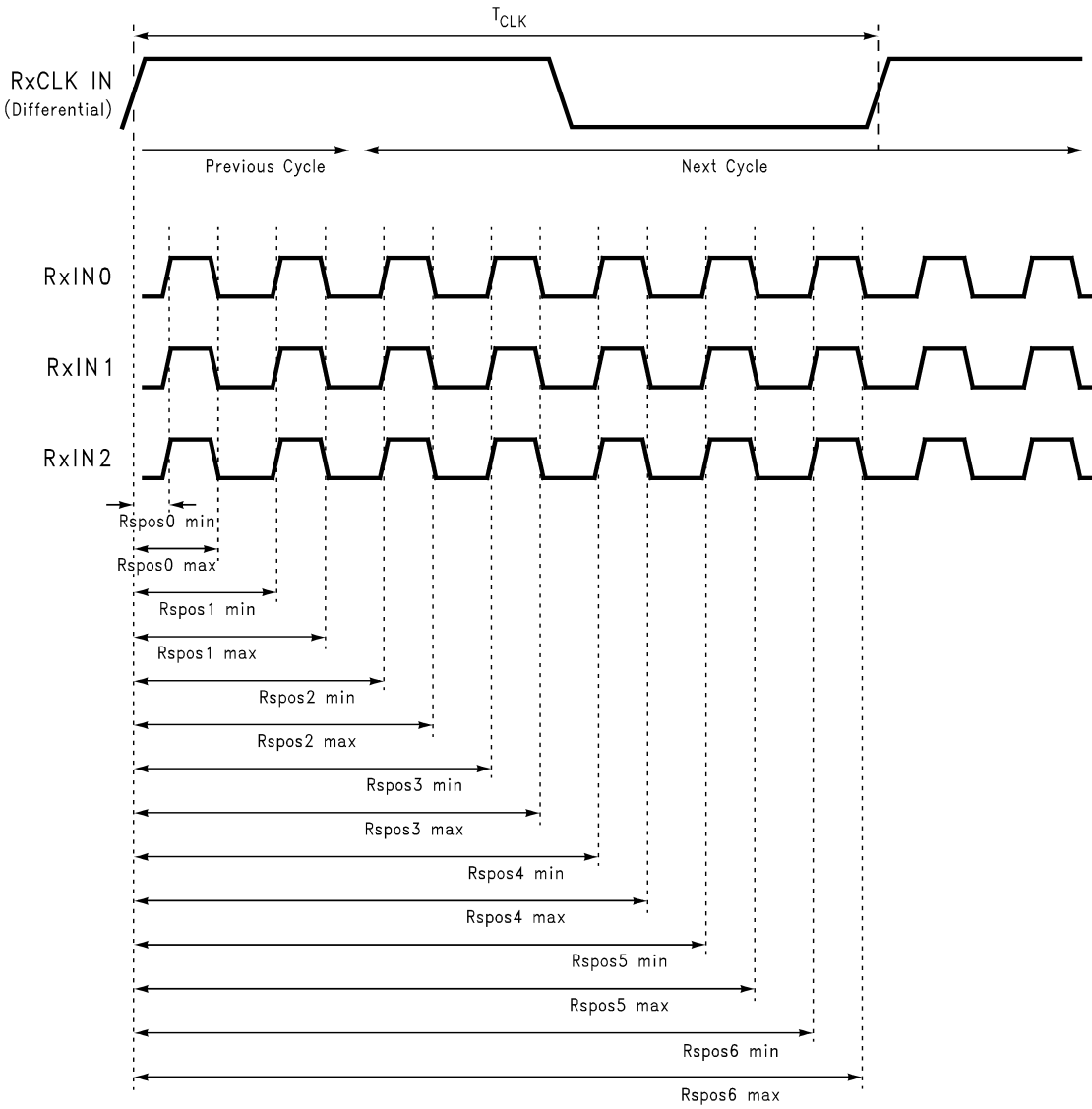

10108526

FIGURE 12. DS90CF366 (Receiver) LVDS Input Strobe Position

AC Timing Diagrams (Continued)

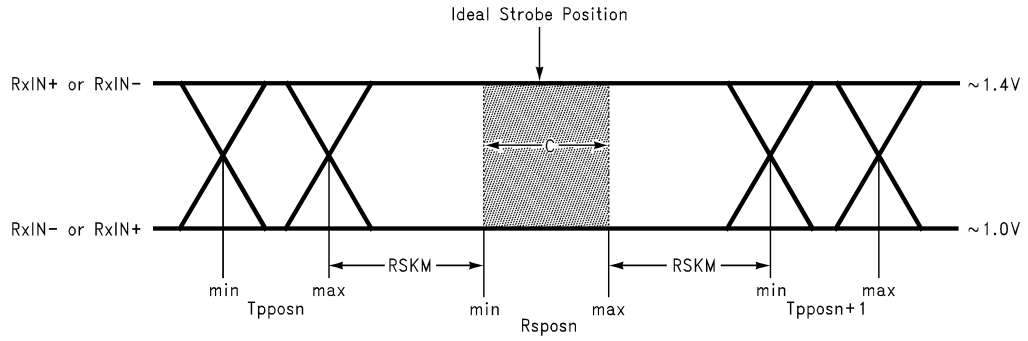

10108511

C—Setup and Hold Time (Internal data sampling window) defined by Rspost (receiver input strobe position) min and max
 Tppos—Transmitter output pulse position (min and max)
 RSKM = Cable Skew (type, length) + Source Clock Jitter (cycle to cycle) (Note 9) + ISI (Inter-symbol interference) (Note 10)
 Cable Skew—typically 10 ps–40 ps per foot, media dependent
Note 9: Cycle-to-cycle jitter is less than 250 ps at 85 MHz.
Note 10: ISI is dependent on interconnect length; may be zero.

FIGURE 13. Receiver LVDS Input Skew Margin

DS90CF386 MTD56 Package Pin Description—24-Bit FPD Link Receiver

Pin Name	I/O	No.	Description
RxIN+	I	4	Positive LVDS differential data inputs.
RxIN-	I	4	Negative LVDS differential data inputs.
RxOUT	O	28	TTL level data outputs. This includes: 8 Red, 8 Green, 8 Blue, and 3 control lines—FPLINE, FPFRAME, DRDY (also referred to as HSYNC, VSYNC, Data Enable).
RxCLK IN+	I	1	Positive LVDS differential clock input.
RxCLK IN-	I	1	Negative LVDS differential clock input.
RxCLK OUT	O	1	TTL level clock output. The falling edge acts as data strobe.
PWR DOWN	I	1	TTL level input. When asserted (low input) the receiver outputs are low.
V _{CC}	I	4	Power supply pins for TTL outputs.
GND	I	5	Ground pins for TTL outputs.
PLL V _{CC}	I	1	Power supply for PLL.
PLL GND	I	2	Ground pin for PLL.
LVDS V _{CC}	I	1	Power supply pin for LVDS inputs.
LVDS GND	I	3	Ground pins for LVDS inputs.

DS90CF366 MTD48 Package Pin Description—18-Bit FPD Link Receiver

Pin Name	I/O	No.	Description
RxIN+	I	3	Positive LVDS differential data inputs.
RxIN-	I	3	Negative LVDS differential data inputs.
RxOUT	O	21	TTL level data outputs. This includes: 6 Red, 6 Green, 6 Blue, and 3 control lines—FPLINE, FPFRAME, DRDY (also referred to as HSYNC, VSYNC, Data Enable).
RxCLK IN+	I	1	Positive LVDS differential clock input.
RxCLK IN-	I	1	Negative LVDS differential clock input.
RxCLK OUT	O	1	TTL level clock output. The falling edge acts as data strobe.
PWR DOWN	I	1	TTL level input. When asserted (low input) the receiver outputs are low.
V _{CC}	I	4	Power supply pins for TTL outputs.
GND	I	5	Ground pins for TTL outputs.
PLL V _{CC}	I	1	Power supply for PLL.
PLL GND	I	2	Ground pin for PLL.
LVDS V _{CC}	I	1	Power supply pin for LVDS inputs.
LVDS GND	I	3	Ground pins for LVDS inputs.

DS90CF386 — 64 ball FBGA package Pin Description — FPD Link Receiver

Pin Name	I/O	No.	Description
RxIN+	I	4	Positive LVDS differential data inputs.
RxIN-	I	4	Negative LVDS differential data inputs.
RxOUT	O	28	TTL level data outputs. This includes: 8 Red, 8 Green, 8 Blue, and 4 control lines—FPLINE, FPFRAME, DRDY (also referred to as HSYNC, VSYNC, Data Enable).
RxCLK IN+	I	1	Positive LVDS differential clock input.
RxCLK IN-	I	1	Negative LVDS differential clock input.
FPSHIFT OUT	O	1	TTL level clock output. The falling edge acts as data strobe. Pin name RxCLK OUT.
PWR DOWN	I	1	TTL level input. When asserted (low input) the receiver outputs are low.
V _{CC}	I	4	Power supply pins for TTL outputs.
GND	I	5	Ground pins for TTL outputs.
PLL V _{CC}	I	1	Power supply for PLL.
PLL GND	I	2	Ground pin for PLL.
LVDS V _{CC}	I	1	Power supply pin for LVDS inputs.

DS90CF386 — 64 ball FBGA package Pin Description — FPD Link Receiver (Continued)

Pin Name	I/O	No.	Description
LVDS GND	I	3	Ground pins for LVDS inputs.
NC		6	Pins not connected.

DS90CF386 Pin Description — 64 ball FBGA Package — FPD Link Receiver

By Pin			By Pin Type		
Pin	Pin Name	Type	Pin	Pin Name	Type
A1	RxOUT17	O	A4	GND	G
A2	VCC	P	B1	GND	G
A3	RxOUT15	O	B6	GND	G
A4	GND	G	D8	GND	G
A5	RxOUT12	O	E3	GND	G
A6	RxOUT8	O	E5	LVDS GND	G
A7	RxOUT7	O	G3	LVDS GND	G
A8	RxOUT6	O	G7	LVDS GND	G
B1	GND	G	H5	LVDS GND	G
B2	NC		F6	PLL GND	G
B3	RxOUT16	O	G8	PLL GND	G
B4	RxOUT11	O	E6	PWR DWN	I
B5	VCC	P	H6	RxCLKIN-	I
B6	GND	G	H7	RxCLKIN+	I
B7	RxOUT5	O	H2	RxIN0-	I
B8	RxOUT3	O	H3	RxIN0+	I
C1	RxOUT21	O	F4	RxIN1-	I
C2	NC		G4	RxIN1+	I
C3	RxOUT18	O	G5	RxIN2-	I
C4	RxOUT14	O	F5	RxIN2+	I
C5	RxOUT9	O	G6	RxIN3-	I
C6	RxOUT4	O	H8	RxIN3+	I
C7	NC		E7	RxCLKOUT	O
C8	RxOUT1	O	E8	RxOUT0	O
D1	VCC	P	C8	RxOUT1	O
D2	RxOUT20	O	D5	RxOUT10	O
D3	RxOUT19	O	B4	RxOUT11	O
D4	RxOUT13	O	A5	RxOUT12	O
D5	RxOUT10	O	D4	RxOUT13	O
D6	VCC	P	C4	RxOUT14	O
D7	RxOUT2	O	A3	RxOUT15	O
D8	GND	G	B3	RxOUT16	O
E1	RxOUT22	O	A1	RxOUT17	O
E2	RxOUT24	O	C3	RxOUT18	O
E3	GND	G	D3	RxOUT19	O
E4	LVDS VCC	P	D7	RxOUT2	O
E5	LVDS GND	G	D2	RxOUT20	O
E6	PWR DWN	I	C1	RxOUT21	O
E7	RxCLKOUT	O	E1	RxOUT22	O
E8	RxOUT0	O	F1	RxOUT23	O

DS90CF386 Pin Description — 64 ball FBGA Package — FPD Link Receiver (Continued)

By Pin			By Pin Type		
F1	RxOUT23	O	E2	RxOUT24	O
F2	RxOUT26	O	G1	RxOUT25	O
F3	NC		F2	RxOUT26	O
F4	RxIN1-	I	H1	RxOUT27	O
F5	RxIN2+	I	B8	RxOUT3	O
F6	PLL GND	G	C6	RxOUT4	O
F7	PLL VCC	P	B7	RxOUT5	O
F8	NC		A8	RxOUT6	O
G1	RxOUT25	O	A7	RxOUT7	O
G2	NC		A6	RxOUT8	O
G3	LVDS GND	G	C5	RxOUT9	O
G4	RxIN1+	I	E4	LVDS VCC	P
G5	RxIN2-	I	H4	LVDS VCC	P
G6	RxIN3-	I	F7	PLL VCC	P
G7	LVDS GND	G	A2	VCC	P
G8	PLL GND	G	B5	VCC	P
H1	RxOUT27	O	D1	VCC	P
H2	RxIN0-	I	D6	VCC	P
H3	RxIN0+	I	B2	NC	
H4	LVDS VCC	P	C2	NC	
H5	LVDS GND	G	C7	NC	
H6	RxCLKIN-	I	F3	NC	
H7	RxCLKIN+	I	F8	NC	
H8	RxIN3+	I	G2	NC	

G: Ground
I: Input
O: Output
P: Power
NC: Not connected

Pin Diagrams for TSSOP Packages

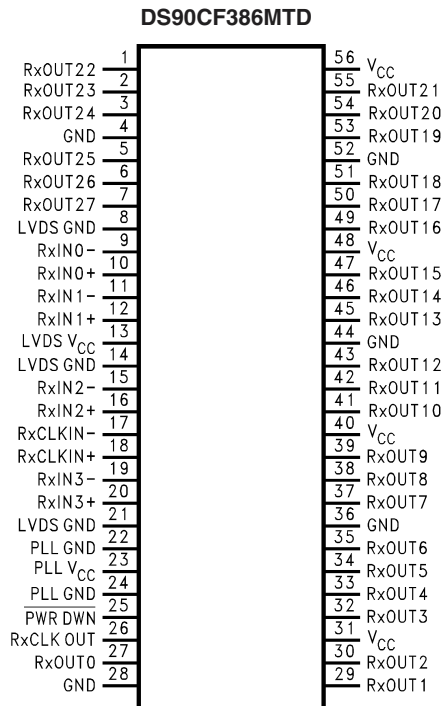

10108523

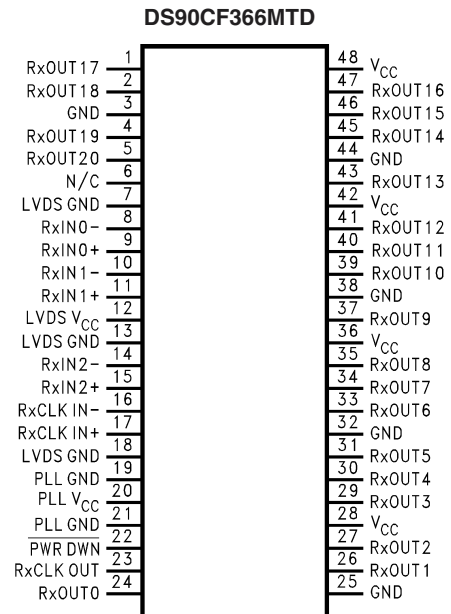

10108513

Applications Information

POWER SEQUENCING AND POWERDOWN MODE

Outputs of the transmitter remain in TRI-STATE until the power supply reaches 2V. Clock and data outputs will begin to toggle 10 ms after V_{CC} has reached 3V and the Powerdown pin is above 1.5V. Either device may be placed into a powerdown mode at any time by asserting the Powerdown pin (active low). Total power dissipation for each device will decrease to 5 μ W (typical).

The transmitter input clock may be applied prior to powering up and enabling the transmitter. The transmitter input clock may also be applied after power up; however, the use of the PWR DOWN pin is required as described in the Transmitter Input Clock section. Do not power up and enable ($\overline{\text{PWR DOWN}} = \text{HIGH}$) the transmitter without a valid clock signal applied to the TxCLK IN pin.

The FPD Link chipset is designed to protect itself from accidental loss of power to either the transmitter or receiver. If power to the transmit board is lost, the receiver clocks (input and output) stop. The data outputs (RxOUT) retain the states they were in when the clocks stopped. When the

receiver board loses power, the receiver inputs are controlled by a failsafe bias circuitry. The LVDS inputs are High-Z during initial power on and power off conditions. Current is limited (5 mA per input) by the fixed current mode drivers, thus avoiding the potential for latchup when powering the device.

RECEIVER FAILSAFE FEATURE

The FPD Link receivers have input failsafe bias circuitry to guarantee a stable receiver output for floating or terminated receiver inputs. Under these conditions receiver inputs will be pulled to a HIGH state. This is the case if not all data channels are required in the application. Leave the extra channel's inputs open. This minimizes power dissipation and locks the unused channels outputs into a stable known (HIGH) state.

If a clock signal is present, data outputs will all be HIGH; if the clock input is also floating/terminated, data outputs will remain in the last valid state. A floating/terminated clock input will result in a LOW clock output.

Physical Dimensions inches (millimeters) unless otherwise noted (Continued)

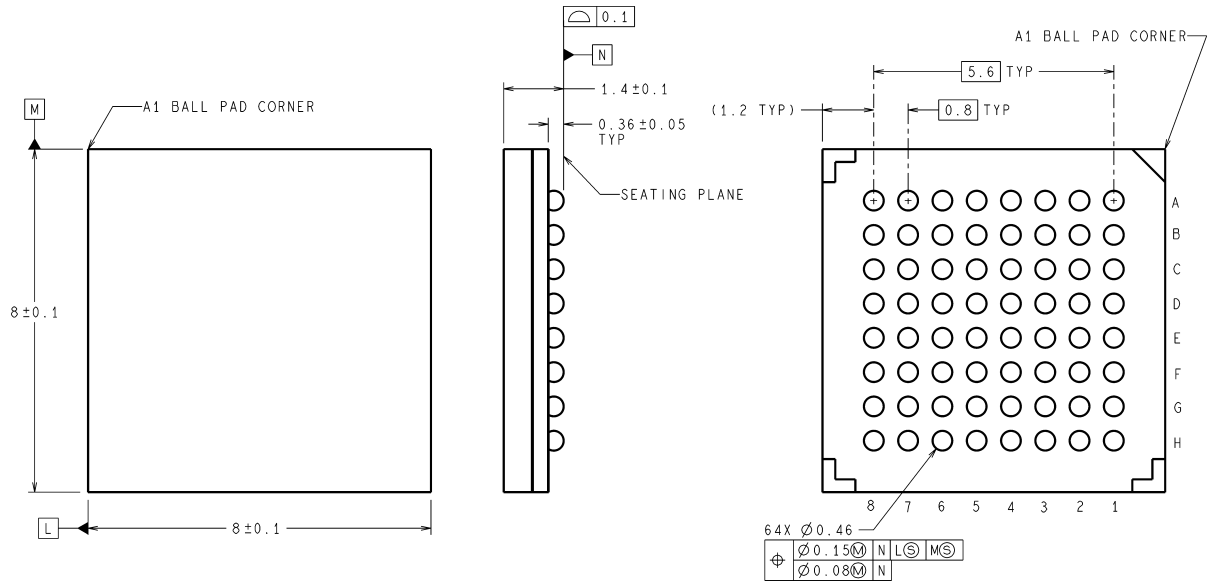

DIMENSIONS ARE IN MILLIMETERS

SLC64A (Rev C)

64 ball, 0.8mm fine pitch ball grid array (FBGA) Package
 Dimensions show in millimeters
 Order Number DS90CF386SLC
 NS Package Number SLC64A

LIFE SUPPORT POLICY

NATIONAL'S PRODUCTS ARE NOT AUTHORIZED FOR USE AS CRITICAL COMPONENTS IN LIFE SUPPORT DEVICES OR SYSTEMS WITHOUT THE EXPRESS WRITTEN APPROVAL OF THE PRESIDENT AND GENERAL COUNSEL OF NATIONAL SEMICONDUCTOR CORPORATION. As used herein:

1. Life support devices or systems are devices or systems which, (a) are intended for surgical implant into the body, or (b) support or sustain life, and whose failure to perform when properly used in accordance with instructions for use provided in the labeling, can be reasonably expected to result in a significant injury to the user.
2. A critical component is any component of a life support device or system whose failure to perform can be reasonably expected to cause the failure of the life support device or system, or to affect its safety or effectiveness.

National Semiconductor
 Americas Customer Support Center
 Email: new.feedback@nsc.com
 Tel: 1-800-272-9959

National Semiconductor
 Europe Customer Support Center
 Fax: +49 (0) 180-530 85 86
 Email: europe.support@nsc.com
 Deutsch Tel: +49 (0) 69 9508 6208
 English Tel: +44 (0) 870 24 0 2171
 Français Tel: +33 (0) 1 41 91 8790

National Semiconductor
 Asia Pacific Customer Support Center
 Email: ap.support@nsc.com

National Semiconductor
 Japan Customer Support Center
 Fax: 81-3-5639-7507
 Email: jpn.feedback@nsc.com
 Tel: 81-3-5639-7560

www.national.com

National Semiconductor was acquired by Texas Instruments.

http://www.ti.com/corp/docs/investor_relations/pr_09_23_2011_national_semiconductor.html

This file is the datasheet for the following electronic components:

DS90CF366MTDX - <http://www.ti.com/product/ds90cf366mtdx?HQS=TI-null-null-dscatalog-df-pf-null-wwe>

DS90CF386MTD - <http://www.ti.com/product/ds90cf386mtd?HQS=TI-null-null-dscatalog-df-pf-null-wwe>

DS90CF386MTDX - <http://www.ti.com/product/ds90cf386mtdx?HQS=TI-null-null-dscatalog-df-pf-null-wwe>

DS90CF386SLC - <http://www.ti.com/product/ds90cf386slc?HQS=TI-null-null-dscatalog-df-pf-null-wwe>

DS90CF386SLCX - <http://www.ti.com/product/ds90cf386slcx?HQS=TI-null-null-dscatalog-df-pf-null-wwe>

DS90CF366MTD - <http://www.ti.com/product/ds90cf366mtd?HQS=TI-null-null-dscatalog-df-pf-null-wwe>



LittleDiode supplies new, hard to find or obsolete electronic components and semiconductors all over the world.

With over two million different components listed you are sure to find the part you need.

Feel free to visit us today at our online store:

LittleDiode.com

Looking forward to providing you with the best possible service.