

DS96172/DS96174 RS-485/RS-422 Quad Differential Line Drivers

General Description

The DS96172 and DS96174 are high speed quad differential line drivers designed to meet EIA Standard RS-485. The devices have TRI-STATE® outputs and are optimized for balanced multipoint data bus transmission at rates up to 10 Mbps. The drivers have wide positive and negative common mode range for multipoint applications in noisy environments. Positive and negative current-limiting is provided which protects the drivers from line fault conditions over a +12V to -7.0V common mode range. A thermal shutdown feature is also provided and occurs at junction temperature of approximately 160°C. The DS96172 features an active high and active low Enable, common to all four drivers. The DS96174 features separate active high Enables for each driver pair. Compatible RS-485 receivers, transceivers, and repeaters are also offered to provide optimum bus performance. The respective device types are DS96173, DS96175, DS96176 AND DS96177.

Features

- Meets EIA Standard RS-485 and RS-422A
- Monotonic differential output switching
- Transmission rate to 10 Mbps
- TRI-STATE outputs
- Designed for multipoint bus transmission
- Common mode output voltage range: -7V to +12V
- Operates from single +5V supply
- Thermal shutdown protection
- DS96172/DS96174 are lead and function compatible with the SN75172/75174 or the AM26LS31/MC3487 respectively

Connection Diagrams

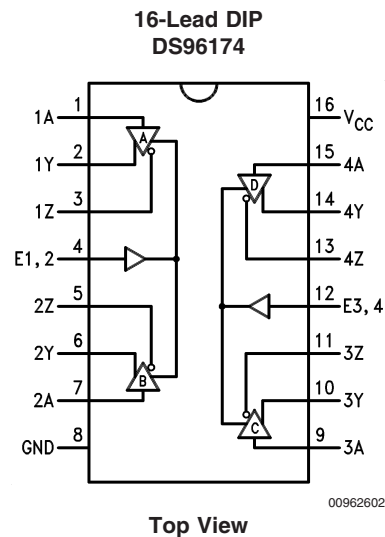
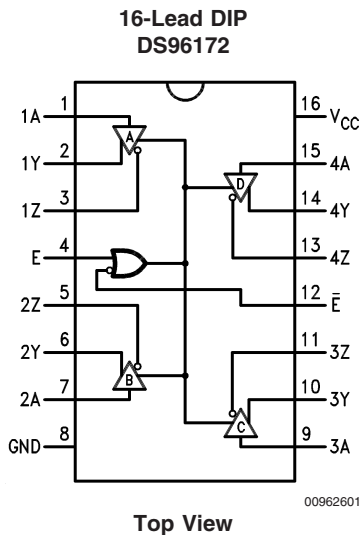

**Order Number DS96172CN or DS96174CN
See NS Package Number N16E**

TRI-STATE® is a registered trademark of National Semiconductor Corporation.

Absolute Maximum Ratings (Note 2)

N-Molded Package

1.98W

If Military/Aerospace specified devices are required, please contact the National Semiconductor Sales Office/Distributors for availability and specifications.

Storage Temperature Range	
Molded DIP	-65°C to +150°C
Operating Temperature Range	0°C to +70°C
Lead Temperature	
Molded DIP (soldering, 10 sec.)	265°C
Supply Voltage	7V
Enable Input Voltage	5.5V
Maximum Power Dissipation (Note 1)	25°C

Recommended Operating Conditions

	Min	Typ	Max	Units
Supply Voltage (V_{CC})	4.75	5	5.25	V
Common Mode Output Voltage (V_{OC})	-7		+12	V
Output Current HIGH (I_{OH})			-60	mA
Output Current LOW (I_{OL})			60	mA
Operating Temperature (T_A)	0	25	70	°C

Note 1: Derate molded DIP package 16mW/°C above 25°C.

Electrical Characteristics (Notes 3, 4)

over recommended temperature and supply voltage ranges, unless otherwise specified

Symbol	Parameter	Conditions	Min	Typ	Max	Units	
V_{IH}	Input Voltage HIGH		2			V	
V_{IL}	Input Voltage LOW				0.8	V	
V_{OH}	Output Voltage HIGH	$I_{OH} = -20$ mA		3.1		V	
V_{OL}	Output Voltage LOW	$I_{OL} = 20$ mA		0.8		V	
V_{IC}	Input Clamp Voltage	$I_I = -18$ mA			-1.5	V	
$ V_{OD1} $	Differential Output Voltage	$I_O = 0$ mA			6	V	
$ V_{OD2} $	Differential Output Voltage	$R_L = 54\Omega$, Figure 1	1.5	2		V	
		$R_L = 100\Omega$, Figure 1	2	2.3		V	
$\Delta V_{OD} $	Change in Magnitude of Differential Output Voltage (Note 5)	$R_L = 54\Omega$ or 100Ω , Figure 1			± 0.2	V	
V_{OC}	Common Mode Output Voltage (Note 6)	$R_L = 54\Omega$, Figure 1			3	V	
$\Delta V_{OC} $	Change in Magnitude of Common Mode Output Voltage (Note 5)				± 0.2	V	
I_O	Output Current with Power Off	$V_{CC} = 0V$, $V_O = -7.0V$ to $12V$			± 100	μA	
I_{OZ}	High Impedance State Output Current	$V_O = -7.0V$ to $12V$		± 50	± 200	μA	
I_{IH}	Input Current HIGH	$V_I = 2.7V$			20	μA	
I_{IL}	Input Current LOW	$V_I = 0.5V$			-100	μA	
I_{OS}	Short Circuit Output Current (Note 7)	$V_O = -7.0V$			-250	mA	
		$V_O = 0V$			-150		
		$V_O = V_{CC}$			150		
		$V_O = 12V$			250		
I_{CC}	Supply Current (All Drivers)	No Load	Outputs Enabled		50	70	mA
			Output Disabled		50	60	

Switching Characteristics

$V_{CC} = 5V$, $T_A = 25^\circ C$

Symbol	Parameter	Conditions	Min	Typ	Max	Units
t_{DD}	Differential Output Delay Time	$R_L = 60\Omega$, Figure 2		15	25	ns
t_{TD}	Differential Output Transition Time			15	25	ns
t_{PLH}	Propagation Delay Time, Low-to-High Level Output	$R_L = 27\Omega$, Figure 3		12	20	ns
t_{PHL}	Propagation Delay Time, High-to-Low Level Output			12	20	ns

Switching Characteristics (Continued)

$V_{CC} = 5V, T_A = 25^\circ C$

Symbol	Parameter	Conditions	Min	Typ	Max	Units
t_{PZH}	Output Enable Time to High Level	$R_L = 110\Omega$, Figure 4		30	45	ns
t_{PZL}	Output Enable Time to Low Level	$R_L = 110\Omega$, Figure 5		30	45	ns
t_{PHZ}	Output Disable Time from High Level	$R_L = 110\Omega$, Figure 4		25	35	ns
t_{PLZ}	Output Disable Time from Low Level	$R_L = 110\Omega$, Figure 5		30	45	ns

Note 2: "Absolute Maximum Ratings" are those values beyond which the safety of the device cannot be guaranteed. They are not meant to imply that the devices should be operated at these limits. The tables of "Electrical Characteristics" provide conditions for actual device operation.

Note 3: Unless otherwise specified min/max limits apply across the $0^\circ C$ to $+70^\circ C$ range for the DS96172/DS96174. All typicals are given for $V_{CC} = 5V$ and $T_A = 25^\circ C$.

Note 4: All currents into the device pins are positive; all currents out of the device pins are negative. All voltages are referenced to ground unless otherwise specified.

Note 5: $\Delta |V_{OD}|$ and $\Delta |V_{OC}|$ are the changes in magnitude of V_{OD} and V_{OC} respectively, that occur when the input is changed from a high level to a low level.

Note 6: In EIA Standards RS-422A and RS-485, V_{OC} , which is the average of the two output voltages with respect to ground, is called output offset voltage, V_{OS} .

Note 7: Only one output at a time should be shorted.

Parameter Measurement Information

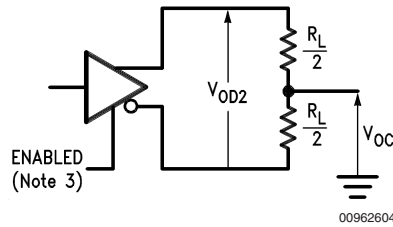

FIGURE 1. Differential and Common Mode Output Voltage

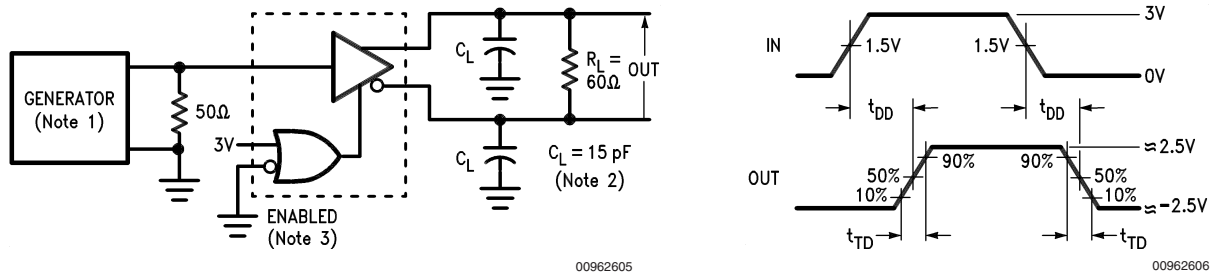
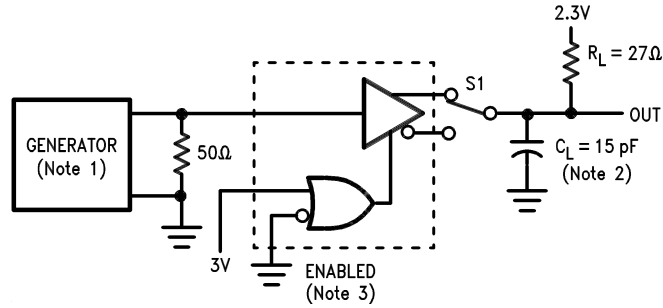
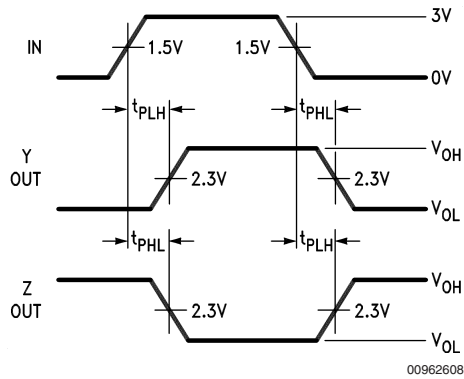

FIGURE 2. Differential Output Delay and Transition Times

Parameter Measurement Information (Continued)



00962607



00962608

FIGURE 3. Propagation Delay Times

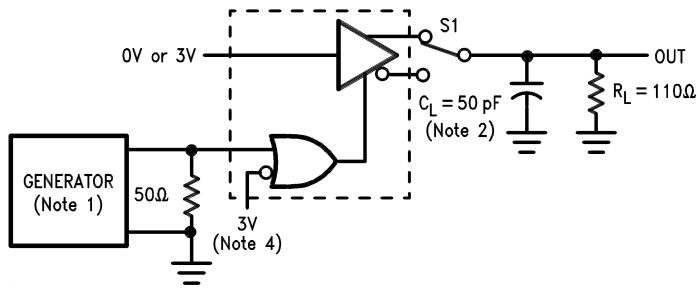

00962609

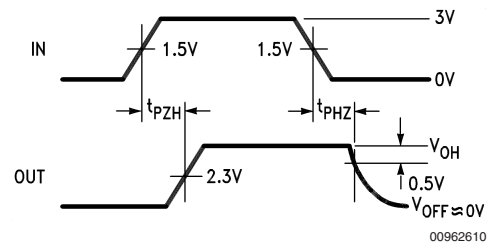

00962610

FIGURE 4. t_{PZH} and t_{PHZ}

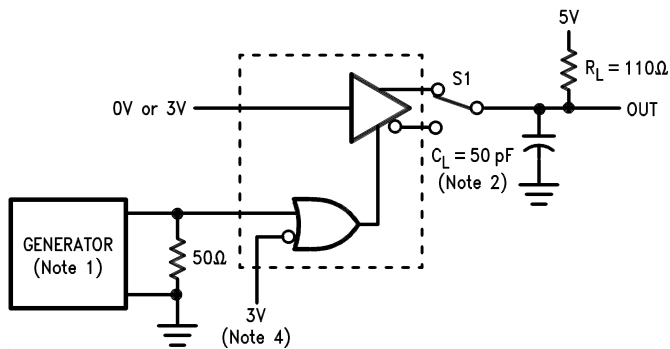

00962611

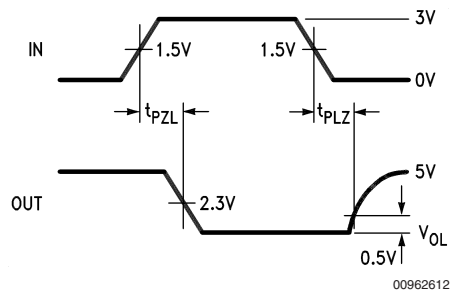

00962612

FIGURE 5. t_{PZL} and t_{PLZ}

Note 8: The input pulse is supplied by a generator having the following characteristics: PRR = 1.0 MHz, duty cycle = 50%, $t_r \leq 5.0$ ns, $t_f \leq 5.0$ ns, $Z_O = 50\Omega$.

Note 9: C_L includes probe and jig capacitance.

Note 10: DS96172 with active high and active low Enables is shown here. DS96174 has active high Enable only.

Note 11: To test the active low Enable \bar{E} of DS96172, ground E and apply an inverted waveform to \bar{E} . DS96174 has active high Enable only.

Function Tables

DS96172

Input A	Enables		Outputs	
	E	\bar{E}	Y	Z
H	H	X	H	L
L	H	X	L	H
H	X	L	H	L
L	X	L	L	H
X	L	H	Z	Z

DS96174

Input	Enable	Outputs	
		Y	Z
H	H	H	L
L	H	L	H
X	L	Z	Z

H = High Level
 X = Immaterial
 L = Low Level
 Z = High Impedance (off)

Typical Application

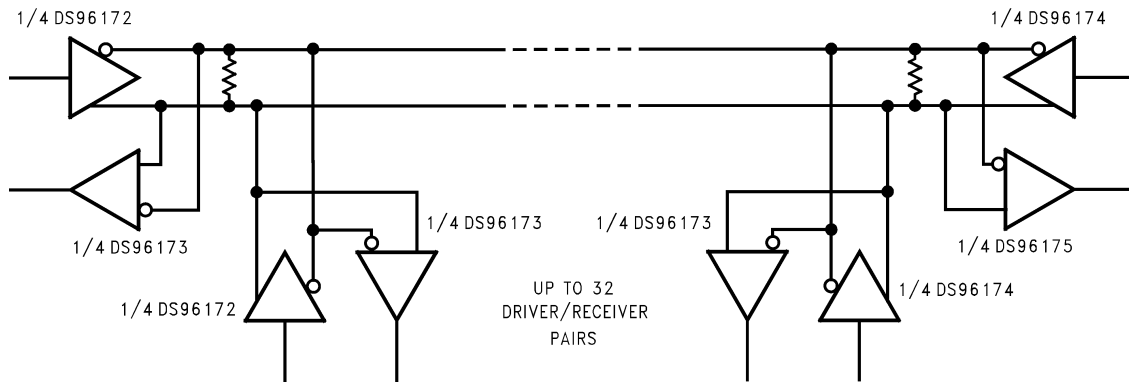

00962613

Note: The line length should be terminated at both ends in its characteristic impedance. Stub lengths off the main line should be kept as short as possible.

FIGURE 6.

Physical Dimensions inches (millimeters)

unless otherwise noted

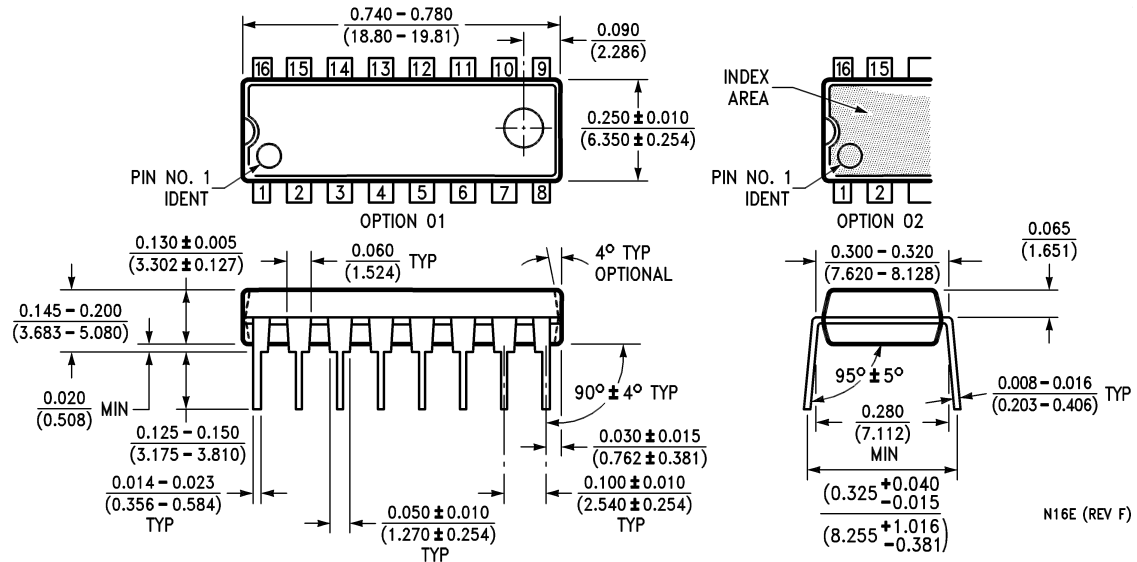

Moulded Dual-In-Line Package (N)
Order Number DS96172CN or DS96174CN
NS Package Number N16E

N16E (REV F)

National does not assume any responsibility for use of any circuitry described, no circuit patent licenses are implied and National reserves the right at any time without notice to change said circuitry and specifications.

For the most current product information visit us at www.national.com.

LIFE SUPPORT POLICY

NATIONAL'S PRODUCTS ARE NOT AUTHORIZED FOR USE AS CRITICAL COMPONENTS IN LIFE SUPPORT DEVICES OR SYSTEMS WITHOUT THE EXPRESS WRITTEN APPROVAL OF THE PRESIDENT AND GENERAL COUNSEL OF NATIONAL SEMICONDUCTOR CORPORATION. As used herein:

- Life support devices or systems are devices or systems which, (a) are intended for surgical implant into the body, or (b) support or sustain life, and whose failure to perform when properly used in accordance with instructions for use provided in the labeling, can be reasonably expected to result in a significant injury to the user.
- A critical component is any component of a life support device or system whose failure to perform can be reasonably expected to cause the failure of the life support device or system, or to affect its safety or effectiveness.

BANNED SUBSTANCE COMPLIANCE

National Semiconductor certifies that the products and packing materials meet the provisions of the Customer Products Stewardship Specification (CSP-9-111C2) and the Banned Substances and Materials of Interest Specification (CSP-9-111S2) and contain no "Banned Substances" as defined in CSP-9-111S2.



National Semiconductor
Americas Customer
Support Center
 Email: new.feedback@nsc.com
 Tel: 1-800-272-9959

National Semiconductor
Europe Customer Support Center
 Fax: +49 (0) 180-530 85 86
 Email: europe.support@nsc.com
 Deutsch Tel: +49 (0) 69 9508 6208
 English Tel: +44 (0) 870 24 0 2171
 Français Tel: +33 (0) 1 41 91 8790

National Semiconductor
Asia Pacific Customer
Support Center
 Email: ap.support@nsc.com

National Semiconductor
Japan Customer Support Center
 Fax: 81-3-5639-7507
 Email: jpn.feedback@nsc.com
 Tel: 81-3-5639-7560

National Semiconductor was acquired by Texas Instruments.

http://www.ti.com/corp/docs/investor_relations/pr_09_23_2011_national_semiconductor.html

This file is the datasheet for the following electronic components:

DS96174CN - <http://www.ti.com/product/ds96174cn?HQS=TI-null-null-dscatalog-df-pf-null-ww>



LittleDiode supplies new, hard to find or obsolete electronic components and semiconductors all over the world.

With over two million different components listed you are sure to find the part you need.

Feel free to visit us today at our online store:

LittleDiode.com

Looking forward to providing you with the best possible service.