

DS96177

RS-485/RS-422 Differential Bus Repeater

General Description

The DS96177 Differential Bus Repeater is a monolithic integrated device designed for one-way data communication on multipoint bus transmission lines. This device is designed for balanced transmission bus line applications and meets EIA Standard RS-485 and RS-422A. The device is designed to improve the performance of the data communication over long bus lines. The DS96177 has an active high Enable.

The DS96177 features positive and negative current limiting and TRI-STATE® outputs for the receiver and driver. The receiver features high input impedance, input hysteresis for increased noise immunity, and input sensitivity of 200 mV over a common mode input voltage range of -12V to +12V. The driver features thermal shutdown for protection from line fault conditions. Thermal shutdown is designed to occur at a junction temperature of approximately 160°C. The driver is designed to drive current loads up to 60 mA maximum.

The DS96177 is designed for optimum performance when used on transmission buses employing the DS96172 and

DS96174 differential line drivers, DS96173 and DS96175 differential line receivers, or DS96176 differential bus transceivers.

Features

- Meets EIA Standard RS-422A and RS-485
- Designed for multipoint transmission on long bus lines in noisy environments
- TRI-STATE outputs
- Bus voltage range -7.0V to +12V
- Positive and negative current limiting
- Driver output capability ±60 mA max
- Driver thermal shutdown protection
- Receiver input high impedance
- Receiver input sensitivity of ±200 mV
- Receiver input hysteresis of 50 mV typical
- Operates from single 5.0V supply
- Low power requirements

Connection Diagram

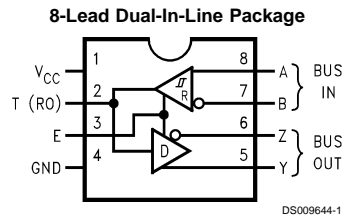

Top View
Order Number DS96177CN
See NS Package Number N08E

Function Table

Differential Inputs	Enable	Outputs		
		T	Y	Z
A-B	E	H	H	L
$V_{ID} \geq 0.2V$	H	H	H	L
$V_{ID} \leq -0.2V$	H	L	L	H
X	L	Z	Z	Z

Note: T is an output pin only, monitoring the BUS (RO).

H = High Level

L = Low Level

X = Immaterial

Z = High Impedance (off)

Absolute Maximum Ratings (Note 2)

If Military/Aerospace specified devices are required, please contact the National Semiconductor Sales Office/Distributors for availability and specifications.

Storage Temperature Range		
Ceramic DIP		-65°C to +175°C
Molded DIP		-65°C to +150°C
Lead Temperature		
Ceramic DIP (Soldering, 60 sec.)		300°C
Molded DIP (Soldering, 10 sec.)		265°C
Maximum Power Dissipation (Note 1) at 25°C		
Molded Package		930 mW
Supply Voltage		7.0V
Input Voltage		5.5V

Recommended Operating Conditions

	Min	Typ	Max	Units
Supply Voltage (V_{CC})	4.75	5.0	5.25	V
Voltage at any Bus Terminal (Separately or Common Mode) (V_I or V_{CM})	-7.0		12	V
Differential Input Voltage (V_{ID})			±12	V
Output Current HIGH (I_{OH})				
Driver			-60	mA
Receiver			-400	µA
Output Current LOW (I_{OL})				
Driver			60	mA
Receiver			16	µA
Operating Temperature (T_A)	0	25	70	°C

Note 1: Derate molded DIP package 7.5 mW/°C above 25°C.

Electrical Characteristics (Notes 3, 4)

Over recommended temperature, common mode input voltage, and supply voltage ranges, unless otherwise specified

Symbol	Parameter	Conditions	Min	Typ	Max	Units
DRIVER SECTION						
V_{IH}	Input Voltage HIGH		2.0			V
V_{IL}	Input Voltage LOW				0.8	V
V_{IC}	Input Clamp Voltage	$I_I = -18$ mA			-1.5	V
$ V_{OD1} $	Differential Output Voltage	$I_O = 0$ mA			6.0	V
$ V_{OD2} $	Differential Output Voltage	$R_L = 100\Omega$, Figure 1	2.0	2.25		V
		$R_L = 54\Omega$, Figure 1 and Figure 2	1.5	2.0		V
$\Delta V_{OD2} $	Change in Magnitude of Differential Output Voltage (Note 5)	$R_L = 100\Omega$, Figure 1			±0.2	V
		$R_L = 54\Omega$, Figure 1 and Figure 2				V
		$V_{CM} = 0V$				
V_{OC}	Common Mode Output Voltage (Note 6)	$R_L = 54\Omega$ or 100Ω			3.0	V
$\Delta V_{OC} $	Change in Magnitude of Common Mode Output Voltage (Note 5)	Figure 1			±0.2	V
I_O	Output Current with Power Off	$V_{CC} = 0V$, $V_O = -7.0V$ to $+12V$			±100	µA
I_{OZ}	High Impedance State Output Current	$V_O = -7.0V$ to $+12V$		±50	±200	µA
I_{IH}	Input Current HIGH	$V_I = 2.7V$			20	µA
I_{IL}	Input Current LOW	$V_I = 0.5V$			-100	µA
I_{OS}	Short Circuit Output Current (Note 10)	$V_O = -7.0V$			-250	mA
		$V_O = 0V$			-150	
		$V_O = V_{CC}$			150	
		$V_O = 12V$			250	
I_{CC}	Supply Current	No Load	Outputs Enabled		35	mA
			Outputs Disabled		40	
RECEIVER SECTION						
V_{TH}	Differential Input High Threshold Voltage	$V_O = 2.7V$, $I_O = -0.4$ mA			0.2	V
V_{TL}	Differential Input Low Threshold Voltage (Note 7)	$V_O = 0.5V$, $I_O = 8.0$ mA	-0.2			V
$V_{T+}-V_{T-}$	Hysteresis (Note 8)	$V_{CM} = 0V$		50		mV
V_{IH}	Enable Input Voltage HIGH		2.0			V
V_{IL}	Enable Input Voltage LOW				0.8	V

Electrical Characteristics (Notes 3, 4) (Continued)

Over recommended temperature, common mode input voltage, and supply voltage ranges, unless otherwise specified

Symbol	Parameter	Conditions	Min	Typ	Max	Units
RECEIVER SECTION						
V_{IC}	Enable Input Clamp Voltage	$I_I = -18 \text{ mA}$			-1.5	V
V_{OH}	High Level Output Voltage	$V_{ID} = 200 \text{ mV}$, $I_{OH} = -400 \text{ } \mu\text{A}$, <i>Figure 3</i>	2.7			V
V_{OL}	Low Level Output Voltage	$V_{ID} = -200 \text{ mV}$, <i>Figure 3</i>	$I_{OL} = 8.0 \text{ mA}$		0.45	V
			$I_{OL} = 16 \text{ mA}$		0.50	
I_{OZ}	High-Impedance State Output	$V_O = 0.4\text{V}$ $V_O = 2.4\text{V}$			-360	μA
					20	
I_I	Line Input Current (Note 9)	Other Input = 0V	$V_I = 12\text{V}$		1.0	mA
			$V_I = -7.0\text{V}$		-0.8	
I_{IH}	Enable Input Current HIGH	$V_{IH} = 2.7\text{V}$			20	μA
I_{IL}	Enable Input Current LOW	$V_{IL} = 0.4\text{V}$			-100	μA
R_I	Input Resistance			12		k Ω
I_{OS}	Short Circuit Output Current	(Note 10)	-15		-85	mA
I_{CC}	Supply Current (Total Package)	No Load	Outputs Enabled		35	mA
			Outputs Disabled		40	

Drive Switching Characteristics

$V_{CC} = 5.0\text{V}$, $T_A = 25^\circ\text{C}$

Symbol	Parameter	Conditions	Min	Typ	Max	Units
t_{DD}	Differential Output Delay Time	$R_L = 60\Omega$, <i>Figure 4</i>		15	25	ns
t_{TD}	Differential Output Transition Time	$R_L = 60\Omega$, <i>Figure 4</i>		15	25	ns
t_{PLH}	Propagation Delay Time, Low-to-High Level Output	$R_L = 27\Omega$, <i>Figure 5</i>		12	20	ns
t_{PHL}	Propagation Delay Time, High-to-Low Level Output	$R_L = 27\Omega$, <i>Figure 5</i>		12	20	ns
t_{PZH}	Output Enable Time to High Level	$R_L = 110\Omega$, <i>Figure 6</i>		25	45	ns
t_{PZL}	Output Enable Time to Low Level	$R_L = 110\Omega$, <i>Figure 7</i>		25	40	ns
t_{PHZ}	Output Disable Time from High Level	$R_L = 110\Omega$, <i>Figure 6</i>		20	25	ns
t_{PLZ}	Output Disable Time from Low Level	$R_L = 110\Omega$, <i>Figure 7</i>		29	35	ns

Receiver Switching Characteristics

$V_{CC} = 5.0\text{V}$, $T_A = 25^\circ\text{C}$

Symbol	Parameter	Conditions	Min	Typ	Max	Units
t_{PLH}	Propagation Delay Time, Low-to-High Level Output	$V_{ID} = 0\text{V to } 3.0\text{V}$, $C_L = 15 \text{ pF}$, <i>Figure 8</i>		16	25	ns
t_{PHL}	Propagation Delay Time, High-to-Low Level Output			16	25	ns
t_{PZH}	Output Enable Time to High Level	$C_L = 15 \text{ pF}$, <i>Figure 9</i>		15	22	ns
t_{PZL}	Output Enable Time to Low Level			15	22	ns
t_{PHZ}	Output Disable Time from High Level	$C_L = 5.0 \text{ pF}$, <i>Figure 9</i>		14	30	ns
t_{PLZ}	Output Disable Time from Low Level			24	40	ns

Note 2: "Absolute Maximum Ratings" are those values beyond which the safety of the device cannot be guaranteed. They are not meant to imply that the devices should be operated at these limits. The tables of "Electrical Characteristics" provide conditions for actual device operation.

Note 3: Unless otherwise specified Min/Max limits apply across the 0°C to $+70^\circ\text{C}$ range for the DS96177. All typicals are given for $V_{CC} = 5\text{V}$ and $T_A = 25^\circ\text{C}$.

Note 4: All currents into the device pins are positive; all currents out of the device pins are negative. All voltages are referenced to ground unless otherwise specified.

Note 5: $\Delta|V_{OD}|$ and $\Delta|V_{OC}|$ are the changes in magnitude of V_{OD} , V_{OC} respectively, that occur when the input is changed from a high level to a low level.

Note 6: In EIA Standards RS-422A and RS-485, V_{OC} , which is the average of the two output voltages with respect to ground, is called output offset voltage, V_{OS} .

Note 7: The algebraic convention, when the less positive (more negative) limit is designated minimum, is used in this data sheet for common mode input voltage and threshold voltage levels only.

Receiver Switching Characteristics (Continued)

Note 8: Hysteresis is the difference between the positive-going input threshold voltage, V_{T+} , and the negative going input threshold voltage, V_{T-} .

Note 9: Refer to EIA Standards RS-485 for exact conditions.

Note 10: Only one output at a time should be shorted.

Parameter Measurement Information

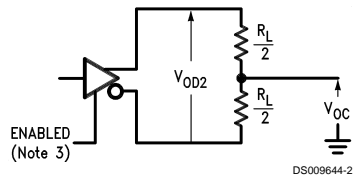

FIGURE 1. Driver V_{OD2} and V_{OC}

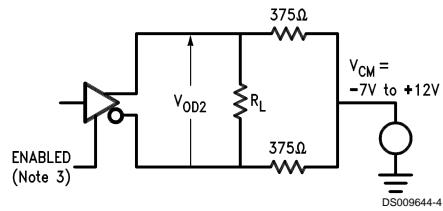

FIGURE 2. Driver V_{OD2} with Varying Common Mode Voltage

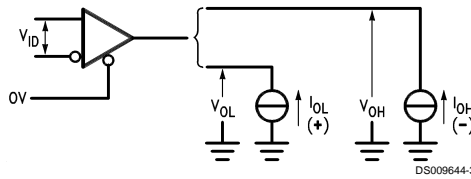

FIGURE 3. Receiver V_{OH} and V_{OL}

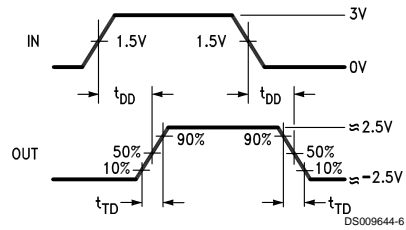
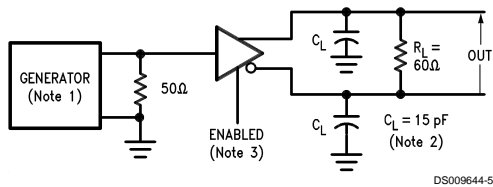

FIGURE 4. Driver Differential Output Delay and Transition Times

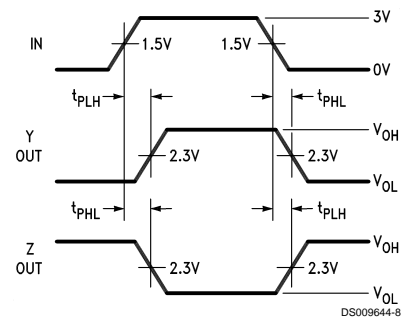
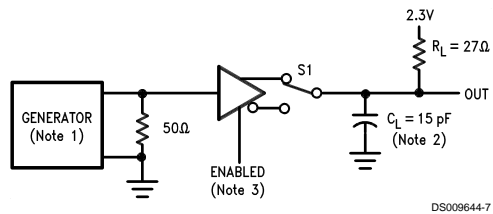
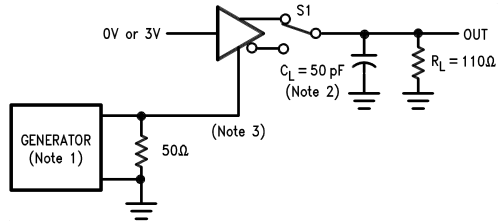
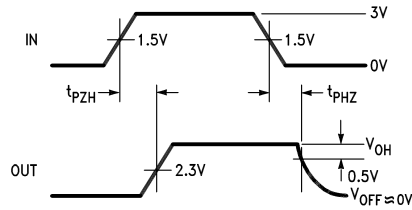

FIGURE 5. Drive Propagation Times

Parameter Measurement Information (Continued)



DS009644-9



DS009644-10

FIGURE 6. Driver Enable and Disable Times (t_{PZH} , t_{PHZ})

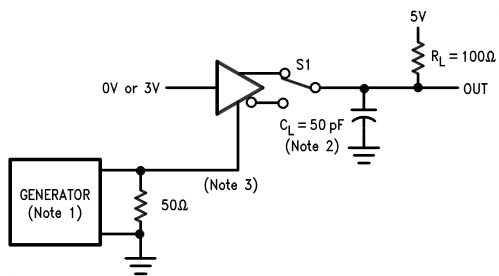

DS009644-11

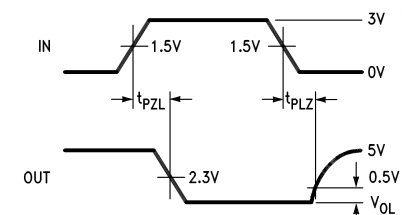

DS009644-12

FIGURE 7. Driver Enable and Disable Times (t_{PZL} , t_{PLZ})

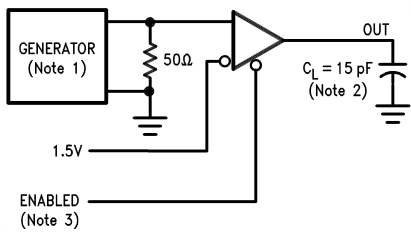

DS009644-13

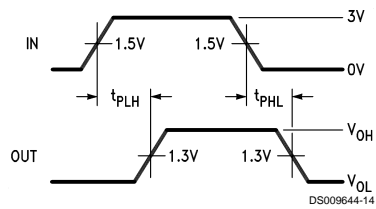

DS009644-14

FIGURE 8. Receiver Propagation Delay Times

Parameter Measurement Information (Continued)

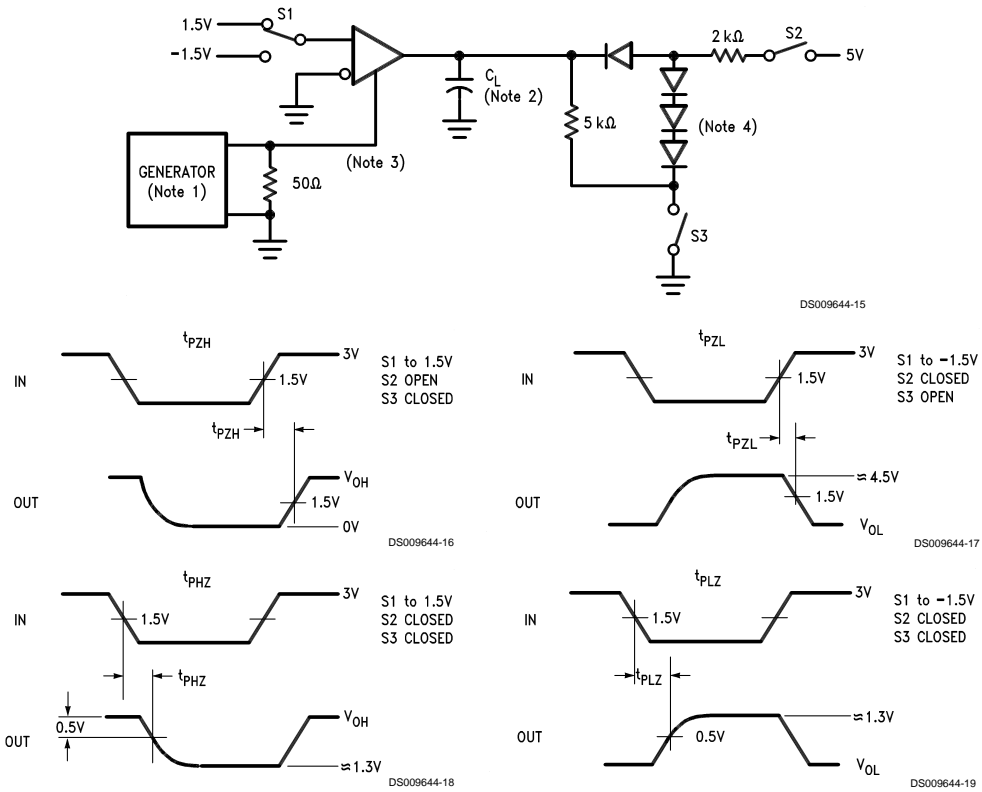

FIGURE 9. Receiver Enable and Disable Times

Note 11: The input pulse is supplied by a generator having the following characteristics: PRR = 1.0 MHz, duty cycle = 50%, $t_r \leq 6.0$ ns, $t_f \leq 6.0$ ns, $Z_O = 50\Omega$.

Note 12: C_L includes probe and stray capacitance.

Note 13: DS96177 Enable is active high.

Note 14: All diodes are 1N916 or equivalent.

Typical Application

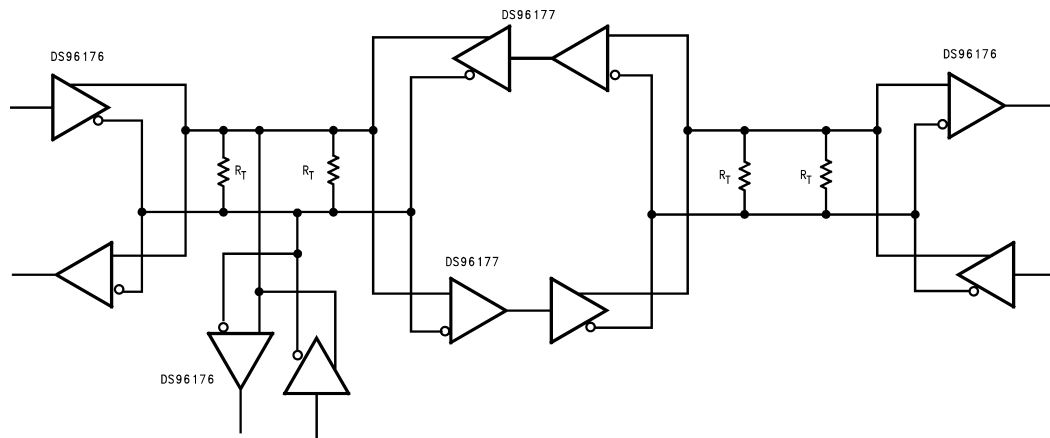

DS009644-20

The line length should be terminated at both ends in its characteristic impedance.
Stub lengths off the main line should be kept as short as possible.
Repeater control logic not shown

FIGURE 10.

Physical Dimensions inches (millimeters) unless otherwise noted

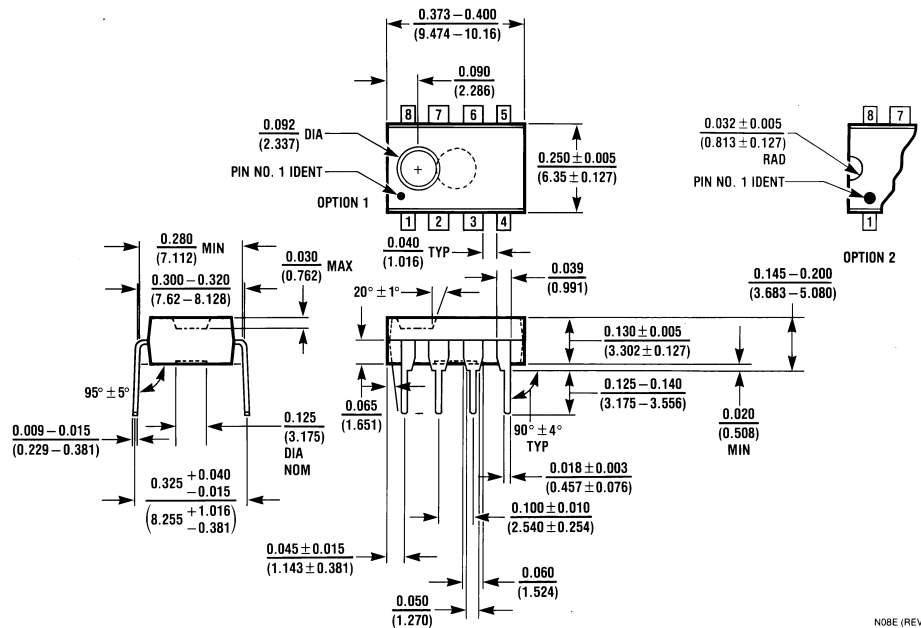

Molded Dual-In-Line Package (N)
 Order Number DS96177CN
 NS Package Number N08E

N08E (REV F)

LIFE SUPPORT POLICY

NATIONAL'S PRODUCTS ARE NOT AUTHORIZED FOR USE AS CRITICAL COMPONENTS IN LIFE SUPPORT DEVICES OR SYSTEMS WITHOUT THE EXPRESS WRITTEN APPROVAL OF THE PRESIDENT OF NATIONAL SEMICONDUCTOR CORPORATION. As used herein:

1. Life support devices or systems are devices or systems which, (a) are intended for surgical implant into the body, or (b) support or sustain life, and whose failure to perform when properly used in accordance with instructions for use provided in the labeling, can be reasonably expected to result in a significant injury to the user.
2. A critical component is any component of a life support device or system whose failure to perform can be reasonably expected to cause the failure of the life support device or system, or to affect its safety or effectiveness.

 **National Semiconductor Corporation**
 Americas
 Tel: 1-800-272-9959
 Fax: 1-800-737-7018
 Email: support@nsc.com

National Semiconductor Europe
 Fax: +49 (0) 1 80-530 85 86
 Email: europe.support@nsc.com
 Deutsch Tel: +49 (0) 1 80-530 85 85
 English Tel: +49 (0) 1 80-532 78 32
 Français Tel: +49 (0) 1 80-532 93 58
 Italiano Tel: +49 (0) 1 80-534 16 80

National Semiconductor Asia Pacific Customer Response Group
 Tel: 65-2544466
 Fax: 65-2504466
 Email: sea.support@nsc.com

National Semiconductor Japan Ltd.
 Tel: 81-3-5639-7560
 Fax: 81-3-5639-7507

www.national.com

This datasheet has been downloaded from:

www.DatasheetCatalog.com

Datasheets for electronic components.

National Semiconductor was acquired by Texas Instruments.

http://www.ti.com/corp/docs/investor_relations/pr_09_23_2011_national_semiconductor.html

This file is the datasheet for the following electronic components:

DS96177CN - <http://www.ti.com/product/ds96177cn?HQS=TI-null-null-dscatalog-df-pf-null-ww>



LittleDiode supplies new, hard to find or obsolete electronic components and semiconductors all over the world.

With over two million different components listed you are sure to find the part you need.

Feel free to visit us today at our online store:

LittleDiode.com

Looking forward to providing you with the best possible service.