

FAST BOOT BLOCK FLASH MEMORY FAMILY 8 AND 16 MBIT

28F800F3, 28F160F3

Includes Extended and Automotive Temperature Specifications

- **High Performance**
 - 54 MHz Effective Zero Wait-State Performance
 - Synchronous Burst-Mode Reads
 - Asynchronous Page-Mode Reads
- **SmartVoltage Technology**
 - 2.7 V–3.6 V Read and Write Operations for Low Power Designs
 - 12 V V_{PP} Fast Factory Programming
- **Flexible I/O Voltage**
 - 1.65 V I/O Reduces Overall System Power Consumption
 - 5 V-Safe I/O Enables Interfacing to 5 V Devices
- **Enhanced Data Protection**
 - Absolute Write Protection with V_{PP} = GND
 - Block Locking
 - Block Erase/Program Lockout during Power Transitions
- **Density Upgrade Path**
 - 8- and 16-Mbit
- **Manufactured on ETOX™ V Flash Technology**
- **Supports Code Plus Data Storage**
 - Optimized for Flash Data Integrator (FDI) Software
 - Fast Program Suspend Capability
 - Fast Erase Suspend Capability
- **Flexible Blocking Architecture**
 - Eight 4-Kword Blocks for Data
 - 32-Kword Main Blocks for Code
 - Top or Bottom Configurations Available
- **Extended Cycling Capability**
 - Minimum 10,000 Block Erase Cycles Guaranteed
- **Low Power Consumption**
 - Automatic Power Savings Mode Decreases Power Consumption
- **Automated Program and Block Erase Algorithms**
 - Command User Interface for Automation
 - Status Register for System Feedback
- **Industry-Standard Packaging**
 - 56-Lead SSOP
 - μBGA* CSP

Intel's Fast Boot Block memory family renders high performance asynchronous page-mode and synchronous burst reads making it an ideal memory solution for burst CPUs. Combining high read performance with the intrinsic non-volatility of flash memory, this flash memory family eliminates the traditional redundant memory paradigm of shadowing code from a slow nonvolatile storage source to a faster execution memory for improved system performance. Therefore, it reduces the total memory requirement which helps increase reliability and reduce overall system power consumption and cost.

This family of products is manufactured on Intel's 0.4 μm ETOX™ V process technology. They are available in industry-standard packages: the μBGA* CSP, ideal for board-constrained applications, and the rugged 56-lead SSOP.

Information in this document is provided in connection with Intel products. No license, express or implied, by estoppel or otherwise, to any intellectual property rights is granted by this document. Except as provided in Intel's Terms and Conditions of Sale for such products, Intel assumes no liability whatsoever, and Intel disclaims any express or implied warranty, relating to sale and/or use of Intel products including liability or warranties relating to fitness for a particular purpose, merchantability, or infringement of any patent, copyright or other intellectual property right. Intel products are not intended for use in medical, life saving, or life sustaining applications.

Intel may make changes to specifications and product descriptions at any time, without notice.

The 28F800F3, 28F160F3 may contain design defects or errors known as errata which may cause the product to deviate from published specifications. Current characterized errata are available on request.

Contact your local Intel sales office or your distributor to obtain the latest specifications and before placing your product order.

Copies of documents which have an ordering number and are referenced in this document, or other Intel literature, may be obtained from:

Intel Corporation
P.O. Box 5937
Denver, CO 80217-9808

or call 1-800-548-4725
or visit Intel's Website at <http://www.intel.com>

COPYRIGHT © INTEL CORPORATION, 1998

CG-041493

*Third-party brands and names are the property of their respective owners

CONTENTS

	PAGE		PAGE
1.0 INTRODUCTION	5	5.0 DATA PROTECTION	26
1.2 Product Overview	5	5.1 $V_{PP} = V_{IL}$ for Complete Protection	26
2.0 PRODUCT DESCRIPTION	6	5.2 $WP\# = V_{IL}$ for Block Locking	26
2.1 Pinouts	6	5.3 $WP\# = V_{IH}$ for Block Unlocking.....	26
2.2 Pin Description	6	6.0 V_{PP} VOLTAGES	26
2.3 Memory Blocking Organization.....	9	7.0 POWER CONSUMPTION	26
2.3.1 Parameter Blocks	9	7.1 Active Power	26
2.3.2 Main Blocks	9	7.2 Automatic Power Savings	26
3.0 PRINCIPLES OF OPERATION	12	7.3 Standby Power.....	27
3.1 Bus Operations	12	7.4 Power-Up/Down Operation.....	27
3.1.1 Read.....	12	7.4.1 RST# Connection	27
3.1.2 Output Disable.....	12	7.4.2 V_{CC} , V_{PP} and RST# Transitions	27
3.1.3 Standby	12	7.5 Power Supply Decoupling	27
3.1.4 Write.....	12	7.5.1 V_{PP} Trace on Printed Circuit Boards.....	27
3.1.5 Reset.....	13	8.0 ELECTRICAL SPECIFICATIONS	28
4.0 COMMAND DEFINITIONS	13	8.1 Absolute Maximum Ratings.....	28
4.1 Read Array Command.....	15	8.2 Extended Temperature Operating	
4.2 Read Identifier Codes Command	15	Conditions	28
4.3 Read Status Register Command.....	15	8.3 Capacitance	29
4.4 Clear Status Register Command.....	15	8.4 DC Characteristics—Extended	
4.5 Block Erase Command	15	Temperature.....	30
4.6 Program Command.....	17	8.5 AC Characteristics—Read-Only	
4.7 Block Erase Suspend/Resume Command .	17	Operations—Extended Temperature	32
4.8 Program Suspend/Resume Command.....	17	8.6 AC Characteristics—Write Operations—	
4.9 Set Read Configuration Command.....	19	Extended Temperature.....	38
4.9.1 Read Configuration.....	19	8.7 AC Characteristics—Reset Operation—	
4.9.2 Frequency Configuration	20	Extended Temperature.....	40
4.9.3 Data Output Configuration	20	8.8 Extended Temperature Block Erase and	
4.9.4 WAIT# Configuration	20	Program Performance	41
4.9.5 Burst Sequence.....	20	8.9 Automotive Temperature Operating	
4.9.6 Clock Configuration	20	Conditions	41
4.9.7 Burst Length.....	20		

8.10 Capacitance	42	9.0 ORDERING INFORMATION.....	46
8.11 DC Characteristics—Automotive Temperature.....	43	10.0 ADDITIONAL INFORMATION	47
8.12 AC Characteristics—Read-Only Operations—Automotive Temperature	44		
8.13 Automotive Temperature Frequency Configuration Settings	45		
8.14 Automotive Temperature Block Erase and Program Performance	45		

REVISION HISTORY

Date of Revision	Version	Description
05/12/98	-001	Original version



1.0 INTRODUCTION

This datasheet contains 8- and 16-Mbit Fast Boot Block memory information. Section 1.0 provides a flash memory overview. Sections 2.0 through 8.0 describe the memory functionality and electrical specifications for extended and automotive temperature product offerings.

1.2 Product Overview

The Fast Boot Block flash memory family provides density upgrades with pinout compatibility for 8- and 16-Mbit densities. This family of products are high performance, low voltage memories with a 16-bit data bus and individually erasable blocks. These blocks are optimally sized for code and data storage. Eight 4-Kword parameter blocks are positioned at either the top (denoted by -T suffix) or bottom (denoted by -B suffix) of the address map. The rest of the device is grouped into 32-Kword main blocks. The upper two (or lower two) parameter and all main blocks can be locked for complete code protection.

The device's optimized architecture and interface dramatically increases read performance beyond previously attainable levels. It supports asynchronous page-mode and synchronous burst reads from main blocks (parameter blocks support single asynchronous and synchronous reads). Upon initial power-up or return from reset, the device defaults to a page-mode read configuration. Page-mode read configuration is ideal for non-clock memory systems and is compatible with page-mode ROM. Synchronous burst reads are enabled by writing to the read configuration register. In synchronous burst mode, the CLK input increments an internal burst address generator, synchronizes the flash memory with the host CPU, and outputs data on every rising (or falling) CLK edge up to 54 MHz (25 MHz for automotive temperature). An output signal, WAIT#, is also provided to ease CPU to flash memory communication and synchronization during continuous burst operations.

In addition to the enhanced architecture and interface, this family of products incorporates SmartVoltage technology which enables fast factory programming and low power designs. Specifically designed for low voltage systems, Fast Boot Block flash memory components support read operations at 2.7 V (3.3 V for automotive temperature) V_{CC} and

block erase and program operations at 2.7 V (3.3 V for automotive temperature) and 12 V V_{PP} . The 12 V V_{PP} option renders the fastest program performance to increase factory programming throughput. With the 2.7 V (3.3 V for automotive temperature) V_{PP} option, V_{CC} and V_{PP} can be tied together for a simple, low power design. In addition to the voltage flexibility, the dedicated V_{PP} pin gives complete data protection when $V_{PP} \leq V_{PPLK}$.

The flexible input/output (I/O) voltage capability helps reduce system power consumption and simplify interfacing to sub 2.7 V and 5 V CPUs. Powered by V_{CCQ} pins, the I/O buffers can operate at a lower voltage than the flash memory core. With V_{CCQ} voltage at 1.65 V, the I/Os swing between GND and 1.65 V, reducing I/O power consumption by 65% over standard 3 V flash memory components. The low voltage and 5 V-safe feature also helps ease CPU interfacing by adapting to the CPU's bus voltage.

The device's Command User Interface (CUI) serves as the interface between the system processor and internal flash memory operation. A valid command sequence written to the CUI initiates device automation. This automation is controlled by an internal Write State Machine (WSM) which automatically executes the algorithms and timings necessary for block erase and program operations. The status register provides WSM feedback by signifying block erase or program completion and status.

Block erase and program automation allows erase and program operations to be executed using an industry-standard two-write command sequence. A block erase operation erases one block at a time, and data is programmed in word increments. Erase suspend allows system software to suspend an ongoing block erase operation in order to read from or program data to any other block. Program suspend allows system software to suspend an ongoing program operation in order to read from any other location.

Fast Boot Block flash memory devices offer two low power savings features: Automatic Power Savings (APS) and standby mode. The device automatically enters APS mode following the completion of a read cycle. Standby mode is initiated when the system deselects the device by driving CE# inactive or RST# active. RST# also resets the device to read array, provides write protection, and clears the status register. Combined, these two features significantly reduce power consumption.

PRODUCT PREVIEW

2.0 PRODUCT DESCRIPTION

This section describes the pinout and block architecture of the device family.

to the 16-Mbit density. The family is available in μ BGA CSP and 56-lead SSOP packages. Pinouts for the 8- and 16-Mbit components are illustrated in Figures 1 and 2.

2.1 Pinouts

Intel's Fast Boot Block flash memory family provides upgrade paths in each package pinout up

2.2 Pin Description

The pin description table describes pin usage.

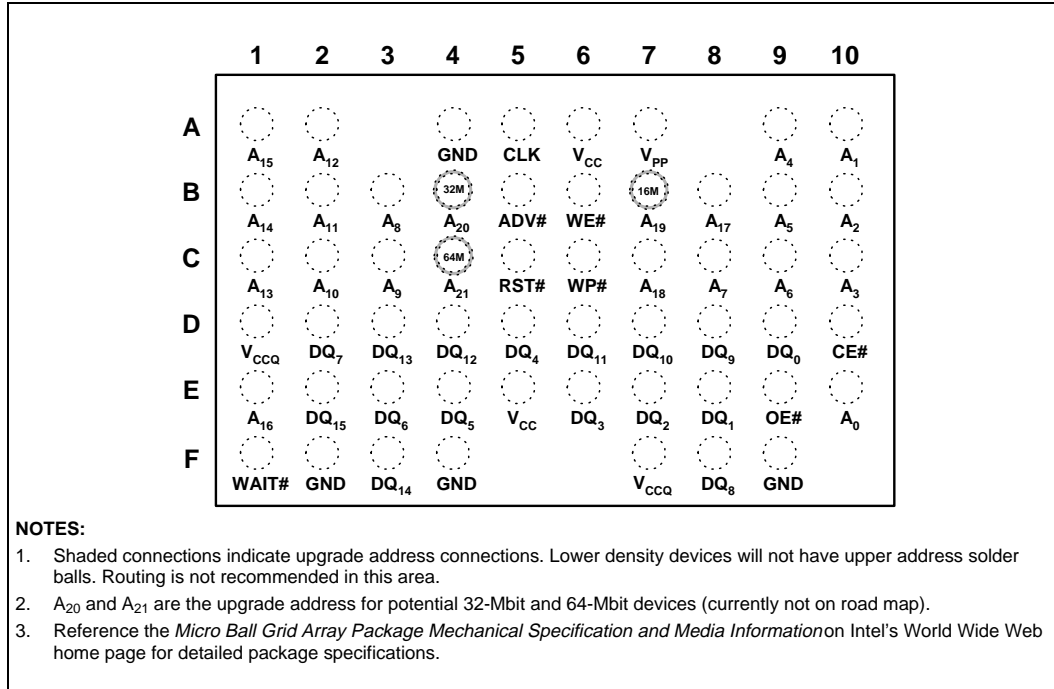

Figure 1. 56-Ball μ BGA* Package Pinout (Top View, Ball Down)

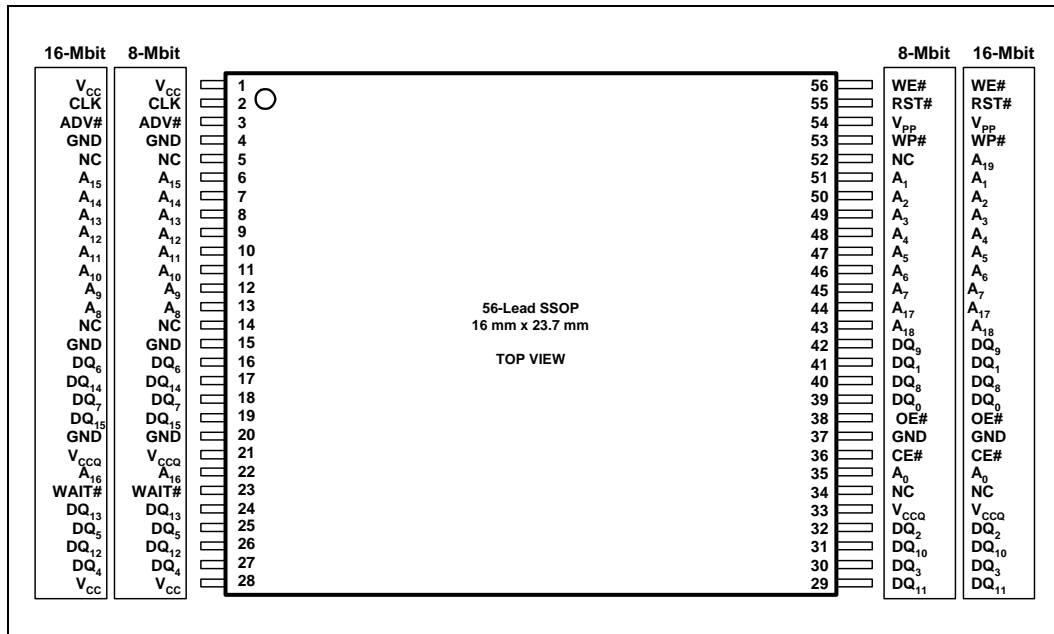

Figure 2. SSOP Pinout

Table 1. Pin Descriptions

Sym	Type	Name and Function
A ₀ –A ₁₉	INPUT	ADDRESS INPUTS: Inputs for addresses during read and write operations. Addresses are internally latched during read and write cycles. 8-Mbit: A ₀ –18, 16-Mbit: A ₀ –19
DQ ₀ – DQ ₁₅	INPUT/ OUTPUT	DATA INPUT/OUTPUTS: Inputs data and commands during write cycles, outputs data during memory array, status register (DQ ₀ –DQ ₇), and identifier code read cycles. Data pins float to high-impedance when the chip is deselected or outputs are disabled. Data is internally latched during a write cycle.
CLK	INPUT	CLOCK: Synchronizes the flash memory to the system operating frequency during synchronous burst-mode read operations. When configured for synchronous burst-mode reads, address is latched on the first rising (or falling, depending upon the read configuration register setting) CLK edge when ADV# is active or upon a rising ADV# edge, whichever occurs first. CLK is ignored during asynchronous page-mode read and write operations.
ADV#	INPUT	ADDRESS VALID: Indicates that a valid address is present on the address inputs. Addresses are latched on the rising edge of ADV# during read and write operations. ADV# may be tied active during asynchronous read and write operations.
CE#	INPUT	CHIP ENABLE: Activates the device's control logic, input buffers, decoders, and sense amplifiers. CE#-high deselected the device and reduces power consumption to standby levels.
RST#	INPUT	RESET: When driven low, RST# inhibits write operations which provides data protection during power transitions, and it resets internal automation. RST#-high enables normal operation. Exit from reset sets the device to asynchronous read array mode.
OE#	INPUT	OUTPUT ENABLE: Gates data outputs during a read cycle.
WE#	INPUT	WRITE ENABLE: Controls writes to the CUI and array. Addresses and data are latched on the rising edge of the WE# pulse.
WP#	INPUT	WRITE PROTECTION: Provides a method for locking and unlocking all main blocks and two parameter blocks. When WP# is at logic low, lockable blocks are locked. If a program or erase operation is attempted on a locked block, SR.1 and either SR.4 [program] or SR.5 [block erase] will be set to indicate the operation failed. When WP# is at logic high, the lockable blocks are unlocked and can be programmed or erased.
WAIT#	OUTPUT	WAIT: Provides data valid feedback when configured for synchronous burst-mode and the burst length is set to continuous. This signal is gated by OE# and CE# and is internally pull-up to V _{CCQ} via a resistor. WAIT# from several components can be tied together to form one system WAIT# signal.

Table 1. Pin Descriptions

Sym	Type	Name and Function
V _{PP}	SUPPLY	BLOCK ERASE AND PROGRAM POWER SUPPLY (2.7 V–3.6 V, 11.4 V–12.6 V): For erasing array blocks or programming data, a valid voltage must be applied to this pin. With $V_{PP} \leq V_{PPLK}$, memory contents cannot be altered. Block erase and program with an invalid V _{PP} voltage should not be attempted. Applying 11.4 V–12.6 V to V _{PP} can only be done for a maximum of 1000 cycles on main blocks and 2500 cycles on the parameter blocks. V _{PP} may be connected to 12 V for a total of 80 hours maximum (see Section 6.0 for details).
V _{CC}	SUPPLY	DEVICE POWER SUPPLY (2.7 V–3.6 V): With $V_{CC} \leq V_{LKO}$, all write attempts to the flash memory are inhibited. Device operations at invalid V _{CC} voltages should not be attempted.
V _{CCQ}	SUPPLY	OUTPUT POWER SUPPLY (1.65 V–2.5 V, 2.7 V–3.6 V): Enables all outputs to be driven to 1.65 V to 2.5 V or 2.7 V to 3.6 V. When V _{CCQ} equals 1.65 V–2.5 V, V _{CC} voltage must not exceed 3.3 V and should be regulated to 2.7 V–2.85 V to achieve lowest power operation (see <i>DC Characteristics</i> for detailed information). This input may be tied directly to V _{CC} .
GND	SUPPLY	GROUND: Do not float any ground pins.
NC		NO CONNECT: Lead is not internally connected; it may be driven or floated.

2.3 Memory Blocking Organization

The Fast Boot Block flash memory family is an asymmetrically-blocked architecture that enables system integration of code and data within a single flash device. For the address locations of each block, see the memory maps in Figure 3 (top boot blocking) and Figure 4 (bottom boot blocking).

2.3.1 PARAMETER BLOCKS

The Fast Boot Block flash memory architecture includes parameter blocks to facilitate storage of frequently updated small parameters that would

normally be stored in an EEPROM. By using software techniques, the word-rewrite functionality of EEPROMs can be emulated. Each 8- and 16-Mbit device contains eight 4-Kwords (4,096-words) parameter blocks.

2.3.2 MAIN BLOCKS

After the parameter blocks, the remainder of the array is divided into equal size main blocks for code and/or data storage. The 8-Mbit device contains fifteen 32-Kword (32,768-word) main blocks, and the 16-Mbit device contains thirty-one 32-Kword (32,768-word) main blocks.

8-Mbit			16-Mbit		
		Address Range			Address Range
Block 22	4-KWord	7F000h - 7FFFFh	Block 38	4-KWord	FF000h - FFFFFh
Block 21	4-KWord	7E000h - 7EFFFh	Block 37	4-KWord	FE000h - FEFFFh
Block 20	4-KWord	7D000h - 7DFFFh	Block 36	4-KWord	FD000h - FDFFFh
Block 19	4-KWord	7C000h - 7CFFFh	Block 35	4-KWord	FC000h - FCFFFh
Block 18	4-KWord	7B000h - 7BFFFh	Block 34	4-KWord	FB000h - FBFFFh
Block 17	4-KWord	7A000h - 7AFFFh	Block 33	4-KWord	FA000h - FAFFFh
Block 16	4-KWord	79000h - 79FFFh	Block 32	4-KWord	F9000h - F9FFFh
Block 15	4-KWord	78000h - 78FFFh	Block 31	4-KWord	F8000h - F8FFFh
Block 14	32-KWord	70000h - 77FFFh	Block 30	32-KWord	F0000h - F7FFFh
Block 13	32-KWord	68000h - 67FFFh	Block 29	32-KWord	E8000h - E7FFFh
Block 12	32-KWord	60000h - 67FFFh	Block 28	32-KWord	E0000h - E7FFFh
Block 11	32-KWord	58000h - 5FFFFh	Block 27	32-KWord	D8000h - D7FFFh
Block 10	32-KWord	50000h - 57FFFh	Block 26	32-KWord	D0000h - D7FFFh
Block 9	32-KWord	48000h - 4FFFFh	Block 25	32-KWord	C8000h - C7FFFh
Block 8	32-KWord	40000h - 47FFFh	Block 24	32-KWord	C0000h - C7FFFh
Block 7	32-KWord	38000h - 3FFFFh	Block 23	32-KWord	B8000h - B7FFFh
Block 6	32-KWord	30000h - 37FFFh	Block 22	32-KWord	B0000h - B7FFFh
Block 5	32-KWord	28000h - 2FFFFh	Block 21	32-KWord	A8000h - A7FFFh
Block 4	32-KWord	20000h - 27FFFh	Block 20	32-KWord	A0000h - A7FFFh
Block 3	32-KWord	18000h - 1FFFFh	Block 19	32-KWord	98000h - 97FFFh
Block 2	32-KWord	10000h - 17FFFh	Block 18	32-KWord	90000h - 97FFFh
Block 1	32-KWord	08000h - 0FFFFh	Block 17	32-KWord	88000h - 87FFFh
Block 0	32-KWord	00000h - 07FFFh	Block 16	32-KWord	80000h - 87FFFh
			Block 15	32-KWord	78000h - 77FFFh
			Block 14	32-KWord	70000h - 77FFFh
			Block 13	32-KWord	68000h - 67FFFh
			Block 12	32-KWord	60000h - 67FFFh
			Block 11	32-KWord	58000h - 5FFFFh
			Block 10	32-KWord	50000h - 57FFFh
			Block 9	32-KWord	48000h - 4FFFFh
			Block 8	32-KWord	40000h - 47FFFh
			Block 7	32-KWord	38000h - 37FFFh
			Block 6	32-KWord	30000h - 37FFFh
			Block 5	32-KWord	28000h - 2FFFFh
			Block 4	32-KWord	20000h - 27FFFh
			Block 3	32-KWord	18000h - 1FFFFh
			Block 2	32-KWord	10000h - 17FFFh
			Block 1	32-KWord	08000h - 0FFFFh
			Block 0	32-KWord	00000h - 07FFFh

Figure 3. 8- and 16-Mbit Top Boot Memory Map

			16-Mbit		Address Range	
			Block 38	32-KWord	F8000h - FFFFFh	
			Block 37	32-KWord	F0000h - F7FFFh	
			Block 36	32-KWord	E8000h - EFFFFh	
			Block 35	32-KWord	E0000h - E7FFFh	
			Block 34	32-KWord	D8000h - DFFFFh	
			Block 33	32-KWord	D0000h - D7FFFh	
			Block 32	32-KWord	C8000h - CFFFFh	
			Block 31	32-KWord	C0000h - C7FFFh	
			Block 30	32-KWord	B8000h - BFFFFh	
			Block 29	32-KWord	B0000h - B7FFFh	
			Block 28	32-KWord	A8000h - AFFFFh	
			Block 27	32-KWord	A0000h - A7FFFh	
			Block 26	32-KWord	98000h - 9FFFFh	
			Block 25	32-KWord	90000h - 97FFFh	
			Block 24	32-KWord	88000h - 8FFFFh	
			Block 23	32-KWord	80000h - 87FFFh	
			Block 22	32-KWord	78000h - 7FFFFh	
			Block 21	32-KWord	70000h - 77FFFh	
			Block 20	32-KWord	68000h - 6FFFFh	
			Block 19	32-KWord	60000h - 67FFFh	
			Block 18	32-KWord	58000h - 5FFFFh	
			Block 17	32-KWord	50000h - 57FFFh	
			Block 16	32-KWord	48000h - 4FFFFh	
			Block 15	32-KWord	40000h - 47FFFh	
			Block 14	32-KWord	38000h - 3FFFFh	
			Block 13	32-KWord	30000h - 37FFFh	
			Block 12	32-KWord	28000h - 2FFFFh	
			Block 11	32-KWord	20000h - 27FFFh	
			Block 10	32-KWord	18000h - 1FFFFh	
			Block 9	32-KWord	10000h - 17FFFh	
			Block 8	32-KWord	08000h - 0FFFFh	
			Block 7	4-KWord	07000h - 07FFFh	
			Block 6	4-KWord	06000h - 06FFFh	
			Block 5	4-KWord	05000h - 05FFFh	
			Block 4	4-KWord	04000h - 04FFFh	
			Block 3	4-KWord	03000h - 03FFFh	
			Block 2	4-KWord	02000h - 02FFFh	
			Block 1	4-KWord	01000h - 01FFFh	
			Block 0	4-KWord	00000h - 00FFFh	

			8-Mbit		Address Range	
			Block 22	32-KWord	78000h - 7FFFFh	
			Block 21	32-KWord	70000h - 77FFFh	
			Block 20	32-KWord	68000h - 6FFFFh	
			Block 19	32-KWord	60000h - 67FFFh	
			Block 18	32-KWord	58000h - 5FFFFh	
			Block 17	32-KWord	50000h - 57FFFh	
			Block 16	32-KWord	48000h - 4FFFFh	
			Block 15	32-KWord	40000h - 47FFFh	
			Block 14	32-KWord	38000h - 3FFFFh	
			Block 13	32-KWord	30000h - 37FFFh	
			Block 12	32-KWord	28000h - 2FFFFh	
			Block 11	32-KWord	20000h - 27FFFh	
			Block 10	32-KWord	18000h - 1FFFFh	
			Block 9	32-KWord	10000h - 17FFFh	
			Block 8	32-KWord	08000h - 0FFFFh	
			Block 7	4-KWord	07000h - 07FFFh	
			Block 6	4-KWord	06000h - 06FFFh	
			Block 5	4-KWord	05000h - 05FFFh	
			Block 4	4-KWord	04000h - 04FFFh	
			Block 3	4-KWord	03000h - 03FFFh	
			Block 2	4-KWord	02000h - 02FFFh	
			Block 1	4-KWord	01000h - 01FFFh	
			Block 0	4-KWord	00000h - 00FFFh	

Figure 4. 8- and 16-Mbit Bottom Boot Memory Map

3.0 PRINCIPLES OF OPERATION

The Fast Boot Block flash memory components include an on-chip WSM to manage block erase and program. It allows for CMOS-level control inputs, fixed power supplies, and minimal processor overhead with RAM-like interface timings.

3.1 Bus Operations

All bus cycles to and from flash memory conform to standard microprocessor bus cycles.

3.1.1 READ

The flash memory has three read modes available: read array, identifier codes, and status register. These modes are accessible independent of the V_{PP} voltage. The appropriate read command (Read Array, Read Identifier Codes, or Read Status Register) must be written to the CUI to enter the requested read mode. Upon initial power-up or exit from reset, the device defaults to read array mode.

When reading information from main blocks in read array mode, the device supports two high-performance read configurations: asynchronous page-mode and synchronous burst-mode. Asynchronous page-mode is the default state and provides high data transfer rate for non-clocked memory subsystems. In this state, data is internally read and stored in a high-speed page buffer. $A_{1:0}$ addresses data in the page buffer. The page size is four words. The other read configuration, synchronous burst-mode, is enabled by writing to read configuration register. This register sets the read configuration, burst order, frequency configuration, and burst length. In synchronous burst-mode, the device latches the initial address then outputs a sequence of data with respect to the input CLK and read configuration setting.

Read operations from the parameter blocks, identifier codes and status register transpire as single asynchronous or synchronous read cycles. The read configuration register setting determines whether or not read operations are asynchronous or synchronous.

For all read operations, CE# must be driven active to enable the devices, ADV# must be driven low to open the internal address latch, and OE# must be driven low to activate the outputs. In asynchronous mode, the address is latched when ADV# is driven high. In synchronous mode, the address is latched by ADV# going high or ADV# low in conjunction with a rising (falling) clock edge, whichever occurs first. WE# must be at V_{IH} . Figures 14 through 19 illustrate different read cycles.

3.1.2 OUTPUT DISABLE

With OE# at a logic-high level (V_{IH}), the device outputs are disabled. Output pins DQ₀–DQ₁₅ are placed in a high-impedance state.

3.1.3 STANDBY

Deselecting the device by bringing CE# to a logic-high level (V_{IH}) places the device in standby mode, which substantially reduces device power consumption. In standby, outputs are placed in a high-impedance state independent of OE#. If deselected during program or erase operation, the device continues to consume active power until the program or erase operation is complete.

3.1.4 WRITE

Commands are written to the CUI using standard microprocessor write timings when ADV#, WE#, and CE# are active and OE# inactive. The CUI does not occupy an addressable memory location. The address is latched on the rising edge of ADV#, WE#, or CE# (whichever occurs first) and data needed to execute a command is latched on the rising edge of WE# or CE# (whichever goes high first). Write operations are asynchronous. Therefore, CLK is ignored during write operations. Figure 20 illustrates a write operation.

3.1.5 RESET

The device enters a reset mode when RST# is driven low. In reset mode, internal circuitry is turned off and outputs are placed in a high-impedance state.

After return from reset, a time t_{PHQV} is required until outputs are valid, and a delay (t_{PHWL} or t_{PHL}) is required before a write sequence can be initiated. After this wake-up interval, normal operation is restored. The device defaults to read array mode, the status register is set to 80H, and the read configuration register defaults to asynchronous page-mode reads.

If RP# is taken low during a block erase or program operation, the operation will be aborted and the memory contents at the aborted location are no longer valid. See Figure 21 for detailed information regarding reset timings.

4.0 COMMAND DEFINITIONS

Device operations are selected by writing specific commands into the CUI. Table 3 defines these commands.

Table 2. Bus Operations

Mode	Notes	RST#	CE#	ADV#	OE#	WE#	Address	V _{PP}	DQ ₀₋₁₅
Reset		V _{IL}	X	X	X	X	X	X	High Z
Standby		V _{IH}	V _{IH}	X	X	X	X	X	High Z
Output Disable		V _{IH}	V _{IL}	X	V _{IH}	V _{IH}	X	X	High Z
Read	1,2	V _{IH}	V _{IL}	V _{IL}	V _{IL}	V _{IH}	X	X	D _{OUT}
Read Identifier Codes		V _{IH}	V _{IL}	V _{IL}	V _{IL}	V _{IH}	See Table 4	X	See Table 4
Write	3,4	V _{IH}	V _{IL}	V _{IL}	V _{IH}	V _{IL}	X	X	D _{IN}

NOTES:

1. Refer to *DC Characteristics*. When $V_{PP} \leq V_{PPLK}$, memory contents can be read, but not altered.
2. X can be V_{IL} or V_{IH} for control and address input pins and V_{PPLK} or V_{PPH1/2} for V_{PP}. See *DC Characteristics* for V_{PPLK} and V_{PPH1/2} voltages.
3. Command writes involving block erase or program are reliably executed when $V_{PP} = V_{PPH1/2}$ and $V_{CC} = V_{CC1/2}$ (see Section 8 for operating conditions at different temperatures).
4. Refer to Table 3 for valid D_{IN} during a write operation.

Table 3. Command Definitions⁽¹⁾

Command	Bus Cycles Req'd.	Notes	First Bus Cycle			Second Bus Cycle		
			Oper ⁽²⁾	Addr ⁽³⁾	Data ⁽⁴⁾	Oper ⁽²⁾	Addr ⁽³⁾	Data ⁽⁴⁾
Read Array/Reset	1		Write	X	FFH			
Read Identifier Codes	≥ 2	5	Write	X	90H	Read	IA	ID
Read Status Register	2		Write	X	70H	Read	X	SRD
Clear Status Register	1		Write	X	50H			
Block Erase	2	6,7	Write	X	20H	Write	BA	D0H
Program	2	6,7,8	Write	X	40H or 10H	Write	WA	WD
Block Erase and Program Suspend	1	6	Write	X	B0H			
Block Erase and Program Resume	1	6	Write	X	D0H			
Set Read Configuration	2		Write	X	60H	Write	RCD	03H

NOTES:

- Commands other than those shown above are reserved by Intel for future device implementations and should not be used.
- Bus operations are defined in Table 2.
- X = Any valid address within the device.
IA = Identifier Code Address.
BA = Address within the block being erased.
WA = Address of memory location to be written.
RCD = Data to be written to the read configuration register. This data is presented to the device on A_{5:0}; set all other address inputs to "0."
- SRD = Data read from status register. See Table 5 for a description of the status register bits.
WD = Data to be written at location WA. Data is latched on the rising edge of WE# or CE# (whichever goes high first).
ID = Data read from identifier codes. See Table 4 for manufacturer and device codes.
RCD = Data to be written to read configuration register. See Table 6 for a description of the read configuration register bits.
- Following the Read Identifier Codes command, read operations access manufacturer, device codes, and read configuration register.
- Following a block erase, program, and suspend operation, read operations access the status register.
- To issue a block erase, program, or suspend operation to a lockable block, hold WP# at V_{IL}.
- Either 40H or 10H are recognized by the WSM as the program setup.

4.1 Read Array Command

Upon initial device power-up or exit from reset, the device defaults to read array mode. The read configuration register defaults to asynchronous page-mode. The Read Array command also causes the device to enter read array mode. The device remains enabled for reads until another command is written. Once the internal WSM has started a block erase or program, the device will not recognize the Read Array command until the WSM completes its operation or unless the WSM is suspended via an Erase or Program Suspend command. The Read Array command functions independently of the V_{PP} voltage.

4.2 Read Identifier Codes Command

The identifier code operation is initiated by writing the Read Identifier Codes command. After writing the command, read cycles retrieve the manufacturer and device codes (see Table 4 for identifier code values). Page-mode and burst reads are not supported in this read mode. To terminate the operation, write another valid command, like the Read Array command. The Read Identifier Codes command functions independently of the V_{PP} voltage.

Table 4. Identifier Codes

Code		Address (Hex)	Data (Hex)
Manufacturer Code		00000	0089
Device Code	8 Mbit	-T	00001
		-B	00001
	16 Mbit	-T	00001
		-B	00001

4.3 Read Status Register Command

The status register can be read at any time by writing the Read Status Register command to the CUI. After writing this command, all subsequent read operations output status register data until

another valid command is written. Page-mode and burst reads are not supported in this read mode. The status register content is updated and latched on the rising edge of ADV# or rising (falling) CLK edge when ADV# is low during synchronous burst-mode or the falling edge of OE# or CE#, whichever occurs first. The Read Status Register command functions independently of the V_{PP} voltage.

4.4 Clear Status Register Command

Status register bits SR.5, SR.4, SR.3, and SR.1 are set to “1”s by the WSM and can only be cleared by issuing the Clear Status Register command. These bits indicate various error conditions. By allowing system software to reset these bits, several operations may be performed (such as cumulatively erasing or writing several bytes in sequence). The status register may be polled to determine if a problem occurred during the sequence. The Clear Status Register command functions independently of the applied V_{PP} voltage. After executing this command, the device returns to read array mode.

4.5 Block Erase Command

Erase is executed one block at a time and initiated by a two-cycle command. A block erase setup is written first, followed by a block erase confirm. This command sequence requires appropriate sequencing and address within the block to be erased (erase changes all block data to FFH). Block preconditioning, erase, and verify are handled internally by the WSM. After the two-cycle block erase sequence is written, the device automatically outputs status register data when read (see Figure 7, *Automated Block Erase Flowchart*). The CPU can detect block erase completion by analyzing status register bit SR.7.

When the block erase completes, check status register bit SR.5 for an error flag (“1”). If an error is detected, check status register bits SR.4, SR.3, and SR.1 to understand what caused the failure. After examining the status register, it should be cleared if an error was detected before issuing a new command. The device will remain in status register read mode until another command is written to the CUI.

Table 5. Status Register Definition

WSMS	ESS	ES	PS	VPPS	PSS	DPS	R
7	6	5	4	3	2	1	0
<p>SR.7 = WRITE STATE MACHINE STATUS (WSMS)</p> <p>1 = Ready 0 = Busy</p> <p>SR.6 = ERASE SUSPEND STATUS (ESS)</p> <p>1 = Block Erase Suspended 0 = Block Erase in Progress/Completed</p> <p>SR.5 = ERASE STATUS (ES)</p> <p>1 = Error in Block Erasure 0 = Successful Block Erase</p> <p>SR.4 = PROGRAM STATUS (PS)</p> <p>1 = Error in Program 0 = Successful Program</p> <p>SR.3 = V_{PP} STATUS (VPPS)</p> <p>1 = V_{PP} Low Detect, Operation Abort 0 = V_{PP} OK</p> <p>SR.2 = PROGRAM SUSPEND STATUS (PSS)</p> <p>1 = Program Suspended 0 = Program in Progress/Completed</p> <p>SR.1 = DEVICE PROTECT STATUS (DPS)</p> <p>1 = Block Erase or Program Attempted on a Locked Block, Operation Abort 0 = Unlocked</p> <p>SR.0 = RESERVED FOR FUTURE ENHANCEMENTS (R)</p>				<p>NOTES:</p> <p>Check SR.7 to determine block erase or program completion. SR.6–0 are invalid while SR.7 = “0.”</p> <p>When an Erase Suspend command is issued, the WSM halts execution and sets both SR.7 and SR.6 to “1.” SR.6 remains set until an Erase Resume command is written to the CUI.</p> <p>If both SR.5 and SR.4 are “1”s after a block erase or program attempt, an improper command sequence was entered.</p> <p>SR.3 does not provide a continuous V_{PP} feedback. The WSM interrogates and indicates the V_{PP} level only after a block erase or program operation. SR.3 is not guaranteed to reports accurate feedback when V_{PP} ≠ V_{PPH1/2} or V_{PPLK}.</p> <p>When an Program Suspend command is issued, the WSM halts execution and sets both SR.7 and SR.2 to “1.” SR.2 remains set until an Program Resume command is written to the CUI.</p> <p>If a block erase or program operation is attempted to a locked block, SR.1 is set by the WSM and aborts the operation if WP# = V_{IL}.</p> <p>SR.0 is reserved for future use and should be masked out when polling the status register.</p>			

4.6 Program Command

Program operation is executed by a two-cycle command sequence. Program setup (standard 40H or alternate 10H) is written, followed by a second write that specifies the address and data. The WSM then takes over, controlling the internal program algorithm. After the program sequence is written, the device automatically outputs status register data when read (see Figure 8, *Automated Program Flowchart*). The CPU can detect the completion of the program event by analyzing status register bit SR.7.

When the program operation completes, check status register bit SR.4 for an error flag ("1"). If an error is detected, check status register bits SR.5, SR.3, and SR.1 to understand what caused the problem. After examining the status register, it should be cleared if an error was detected before issuing a new command. The device will remain in status register read mode until another command is written to the CUI.

4.7 Block Erase Suspend/Resume Command

The Block Erase Suspend command allows block erase interruption to read or program data in another blocks. Once the block erase process starts, writing the Block Erase Suspend command requests that the WSM suspend the block erase operation after a certain latency period. The device continues to output status register data when read after the Block Erase Suspend command is issued. Status Register bits SR.7 and SR.6 indicate when the block erase operation has been suspended (both will be set to "1"). Specification t_{WHRH2} defines the block erase suspend latency.

At this point, a Read Array command can be written to read data from blocks other than that which is suspended. A Program command sequence can also be issued during erase suspend to program data in other blocks. Using the Program Suspend command (see Section 4.8), a program operation can be suspended during an erase suspend. The only other valid commands while block erase is suspended are Read Status Register and Block Erase Resume.

During a block erase suspend, the chip can go into a pseudo-standby mode by taking CE# to V_{IH} , which reduces active current draw. V_{PP} must remain at $V_{PPH1/2}$ while block erase is suspended. WP# must also remain at V_{IL} or V_{IH} .

To resume the block erase operation, write the Block Erase Resume command to the CUI. This will automatically clear status register bits SR.6 and SR.7. After the Erase Resume command is written, the device automatically outputs status register data when read (see Figure 9, *Block Erase Suspend/Resume Flowchart*). Block erase cannot resume until program operations initiated during block erase suspend have completed.

4.8 Program Suspend/Resume Command

The Program Suspend command allows program interruption to read data in other flash memory locations. Once the program process starts, writing the Program Suspend command requests that the WSM suspend the program operation after a certain latency period. The device continues to output status register data when read after issuing Program Suspend command. Status register bits SR.7 and SR.2 indicate when the block erase operation has been suspended (both will be set to "1"). Specification t_{WHRH1} defines the program suspend latency.

At this point, a Read Array command can be written to read data from blocks other than that which is suspended. The only other valid commands while block erase is suspended are Read Status Register and Program Resume.

During a program suspend, the chip can go into a pseudo-standby mode by taking CE# to V_{IH} , which reduces active current draw. V_{PP} must remain at $V_{PPH1/2}$ while program is suspended. WP# must also remain at V_{IL} or V_{IH} .

To resume the program, write the Program Resume command to the CUI. This will automatically clear status register bits SR.7 and SR.2. After the Erase Resume command is written, the device automatically outputs status register data when read (see Figure 10, *Program Suspend/Resume Flowchart*).

Table 6. Read Configuration Register Definition

RM	R	FC2	FC1	FC0	R	DOC	WC
15	14	13	12	11	10	9	8
BS	CC	R	R	R	BL2	BL1	BL0
7	6	5	4	3	2	1	0

<p>RCR.15 = READ MODE (RM) 0 = Synchronous Burst Reads Enabled 1 = Page-Mode Reads Enabled (Default)</p> <p>RCR.14 = RESERVED FOR FUTURE ENHANCEMENTS (R)</p> <p>RCR.13–11 = FREQUENCY CONFIGURATION (FC2-0) 001 = Code 1 reserved for future use 010 = Code 2 011 = Code 3 100 = Code 4 101 = Code 5 110 = Code 6</p> <p>RCR.10 = RESERVED FOR FUTURE ENHANCEMENTS (R)</p> <p>RCR.9 = DATA OUTPUT CONFIGURATION (DOC) 0 = Hold Data for One Clock 1 = Hold Data for Two Clocks</p> <p>RCR.8 = WAIT CONFIGURATION (WC) 0 = WAIT# Asserted During Delay 1 = WAIT# Asserted One Data Cycle Before Delay</p> <p>RCR.7 = BURST SEQUENCE (BS) 0 = Intel Burst Order 1 = Linear Burst Order</p> <p>RCR.6 = CLOCK CONFIGURATION (CC) 0 = Burst Starts and Data Output on Falling Clock Edge 1 = Burst Starts and Data Output on Rising Clock Edge</p> <p>RCR.5–3 = RESERVED FOR FUTURE ENHANCEMENTS (R)</p> <p>RCR.2–0 = BURST LENGTH (BL2–0) 001 = 4 Word Burst 010 = 8 Word Burst 111 = Continuous Burst</p>	<p>NOTES:</p> <p>Read mode configuration effects reads from main blocks. Parameter block, status register, and identifier reads support single read cycles.</p> <p>These bits are reserved for future use. Set these bits to “0.”</p> <p>See Section 4.9.2 for information about the frequency configuration and its effect on the initial read.</p> <p>Undocumented combinations of bits RCR.14–11 are reserved by Intel Corporation for future implementations and should not be used.</p> <p>These bits are reserved for future use. Set these bits to “0.”</p> <p>Undocumented combinations of bits RCR.10–9 are reserved by Intel Corporation for future implementations and should not be used.</p> <p>These bits are reserved for future use. Set these bits to “0.”</p> <p>In the asynchronous page mode, the burst length always equals four words. Undocumented combinations of bits RCR.2–0 are reserved by Intel Corporation for future implementations and should not be used</p>
--	---

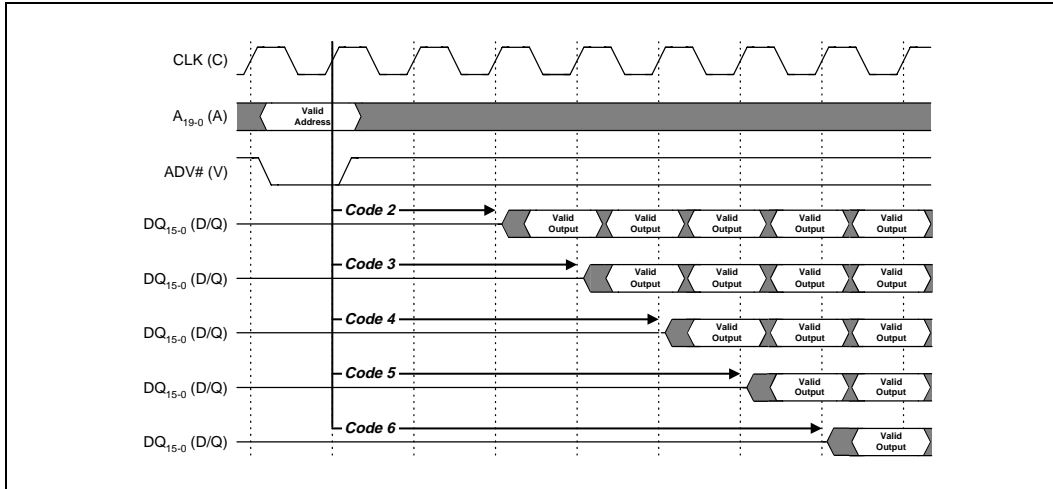

Figure 5. Frequency Configuration

Table 7. Frequency Configuration Settings⁽¹⁾

Frequency Configuration	Input CLK Frequency		
	Product = -90		Product = -120
	V _{CC} = 3.0 V-3.6 V	V _{CC} = 2.7 V-3.6 V	V _{CC} = 2.7 V-3.6 V
Code			
1	Reserved	Reserved	Reserved
2	≤ 27 MHz	≤ 25 MHz	≤ 20 MHz
3	≤ 40 MHz	≤ 33 MHz	≤ 28 MHz
4	≤ 54 MHz	≤ 50 MHz	≤ 40 MHz
5	≤ 66 MHz	≤ 60 MHz	≤ 50 MHz
6	-	≤ 66 MHz	≤ 60 MHz

NOTES:

- Reference Section 4.1. *Automotive Temperature Frequency Configuration Settings* for the corresponding frequency configuration codes to different input CLK frequencies.

4.9 Set Read Configuration Command

The Set Read Configuration command writes data to the read configuration register. This operation is initiated by a two-cycle command sequence. Read configuration setup is written, followed by a second write that specifies the data to be written to the read configuration register. This data is placed on the address bus, A_{15:0}, and is latched on the rising edge of ADV#, CE#, or WE# (whichever occurs

first). The read configuration data sets the device's read configuration, burst order, frequency configuration, and burst length. The command functions independently of the applied V_{PP} voltage. After executing this command, the device returns to read array mode.

4.9.1 READ CONFIGURATION

The device supports two high performance read configurations: asynchronous page-mode and

synchronous burst-mode. Bit RCR.15 in the read configuration register sets the read configuration. Asynchronous page-mode is the default read configuration state.

Parameter blocks, status register, and identifier only support single asynchronous and synchronous read operations.

4.9.2 FREQUENCY CONFIGURATION

The frequency configuration informs the device of the number of clocks that must elapse after ADV# is driven active before data will be available. This value is determined by the input clock frequency. See Table 7 for the specific input CLK frequency configuration code

Figure 5 illustrates data output latency from ADV# going active for different frequency configuration codes.

4.9.3 DATA OUTPUT CONFIGURATION

The output configuration determines how many clocks data will be held valid. The data hold time is configurable as either one or two clocks.

The data output configuration must be set to hold data valid for two clock cycles when the frequency configuration value 4 and burst length is greater than four words. Otherwise, its setting will depend on the system CPU's data setup requirement.

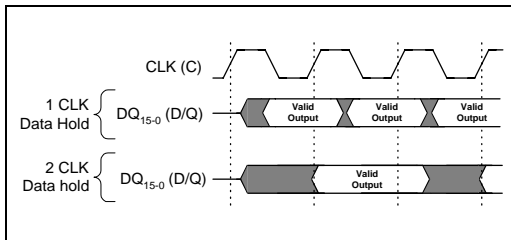

Figure 6. Output Configuration

4.9.4 WAIT# CONFIGURATION

The WAIT# configuration bit controls the behavior of the WAIT# output signal. This output signal can be set to be asserted during or one CLK cycle before an output delay when continuous burst

length is enabled. Its setting will depend on the system and CPU characteristic.

4.9.5 BURST SEQUENCE

The burst sequence specifies the order in which data is addressed in synchronous burst-mode. This order is programmable as either linear or Intel burst order. The continuous burst length only supports linear burst order. The order chosen will depend on the CPU characteristic. See Table 8 for more details.

4.9.6 CLOCK CONFIGURATION

The clock configuration configures the device to start a burst cycle, output data, and assert WAIT# on the rising or falling edge of the clock. CLK flexibility helps ease Fast Boot Block flash memory interface to wide range of burst CPUs.

4.9.7 BURST LENGTH

The burst length is the number of words that the device will output. The device supports burst lengths of four and eight words. It also supports a continuous burst mode. In continuous burst mode, the device will linearly output data until the internal burst counter reaches the end of the device's burstable address space. Bits RCR.2-0 in the read configuration register set the burst length.

4.9.7.1 Continuous Burst Length

When operating in the continuous burst mode, the flash memory may incur an output delay when the burst sequence crosses the first sixteen word boundary. The starting address dictates whether or not a delay will occur. If the starting address is aligned to a four word boundary, the delay will not be seen. If the starting address is the end of a four word boundary, the output delay will be equal to the frequency configuration setting; this is the worst case delay. The delay will only take place once during a continuous burst access, and if the burst sequence never crosses a sixteen word boundary, the delay will never happen. Using the WAIT# output pin in the continuous burst configuration, the system is informed if this output delay occurs.

Table 8. Sequence and Burst Length

Starting Addr. (Dec)	Burst Addressing Sequence (Dec)				
	4 Word Burst Length		8 Word Burst Length		Continuous Burst
	Linear	Intel	Linear	Intel	Linear
0	0-1-2-3	0-1-2-3	0-1-2-3-4-5-6-7	0-1-2-3-4-5-6-7	0-1-2-3-4-5-6-...
1	1-2-3-0	1-0-3-2	1-2-3-4-5-6-7-0	1-0-3-2-5-4-7-6	1-2-3-4-5-6-7-...
2	2-3-0-1	2-3-0-1	2-3-4-5-6-7-0-1	2-3-0-1-6-7-4-5	2-3-4-5-6-7-8-...
3	3-0-1-2	3-2-1-0	3-4-5-6-7-0-1-2	3-2-1-0-7-6-5-4	3-4-5-6-7-8-9-...
⋮	⋮	⋮	⋮	⋮	⋮
6			6-7-0-1-2-3-4-5	6-7-4-5-2-3-0-1	6-7-8-9-10-11-12-...
7			7-0-1-2-3-4-5-6	7-6-5-4-3-2-1-0	7-8-9-10-11-12-13-...
⋮					⋮
14					14-15-16-17-18-19-20-...
15					15-16-17-18-19-20-21-...
⋮					⋮

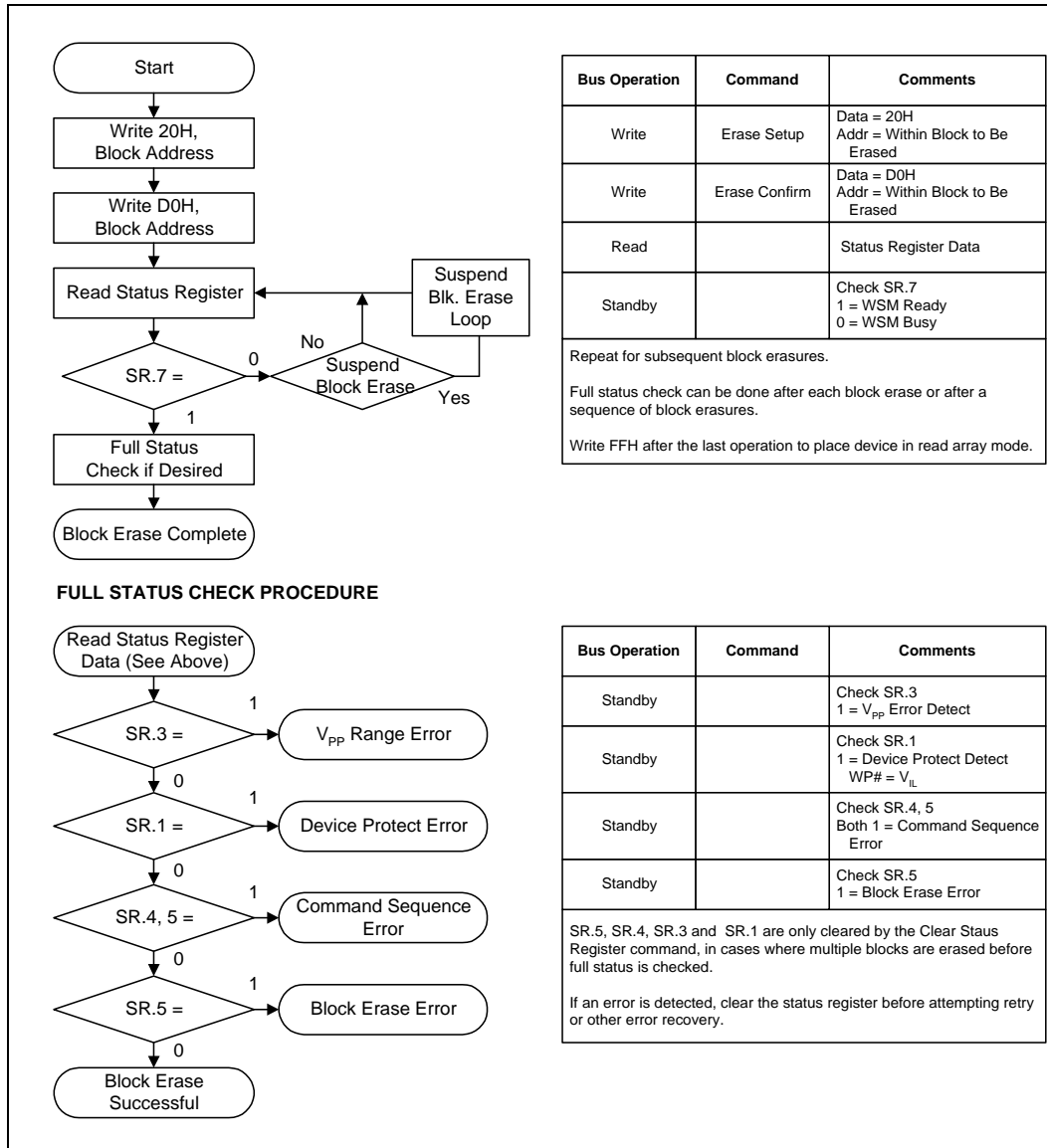

Figure 7. Automated Block Erase Flowchart

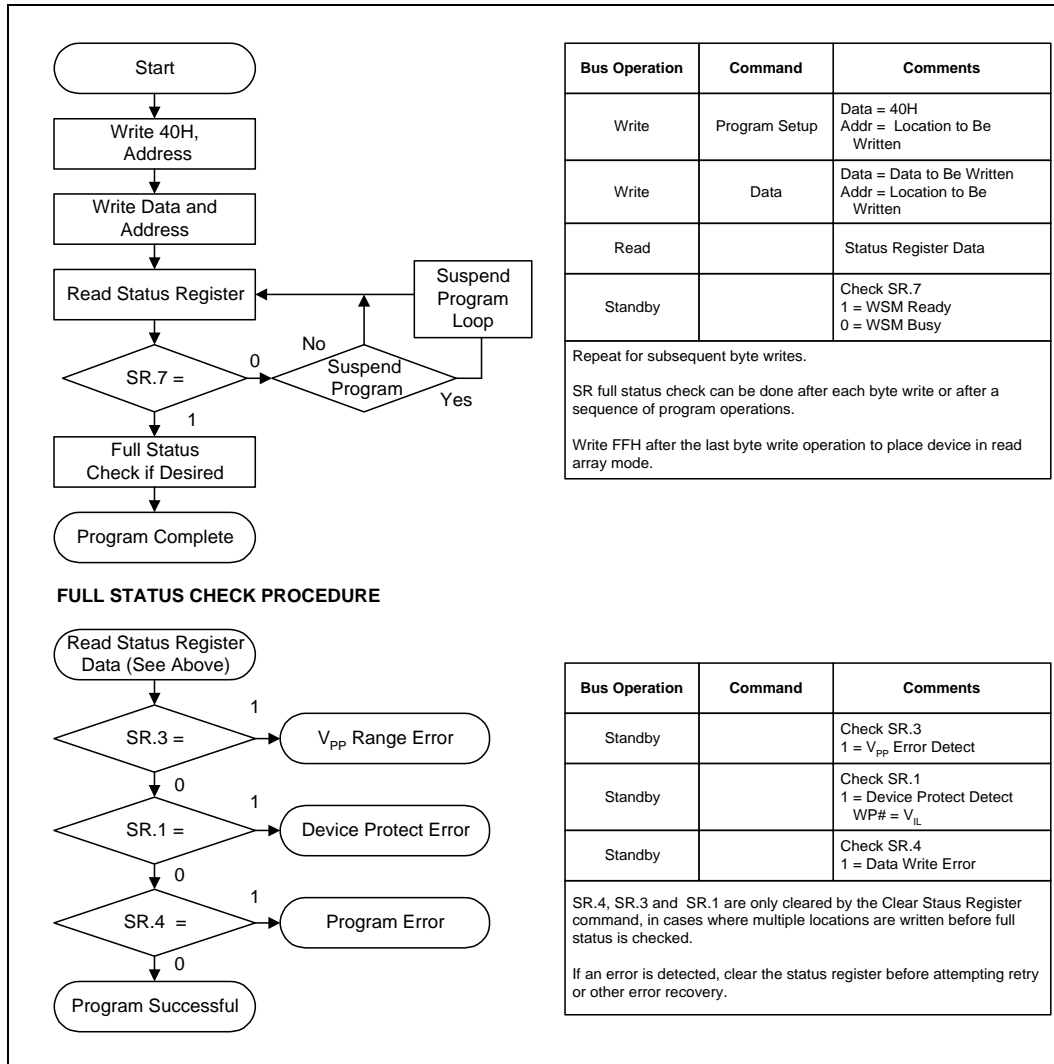

Figure 8. Automated Program Flowchart

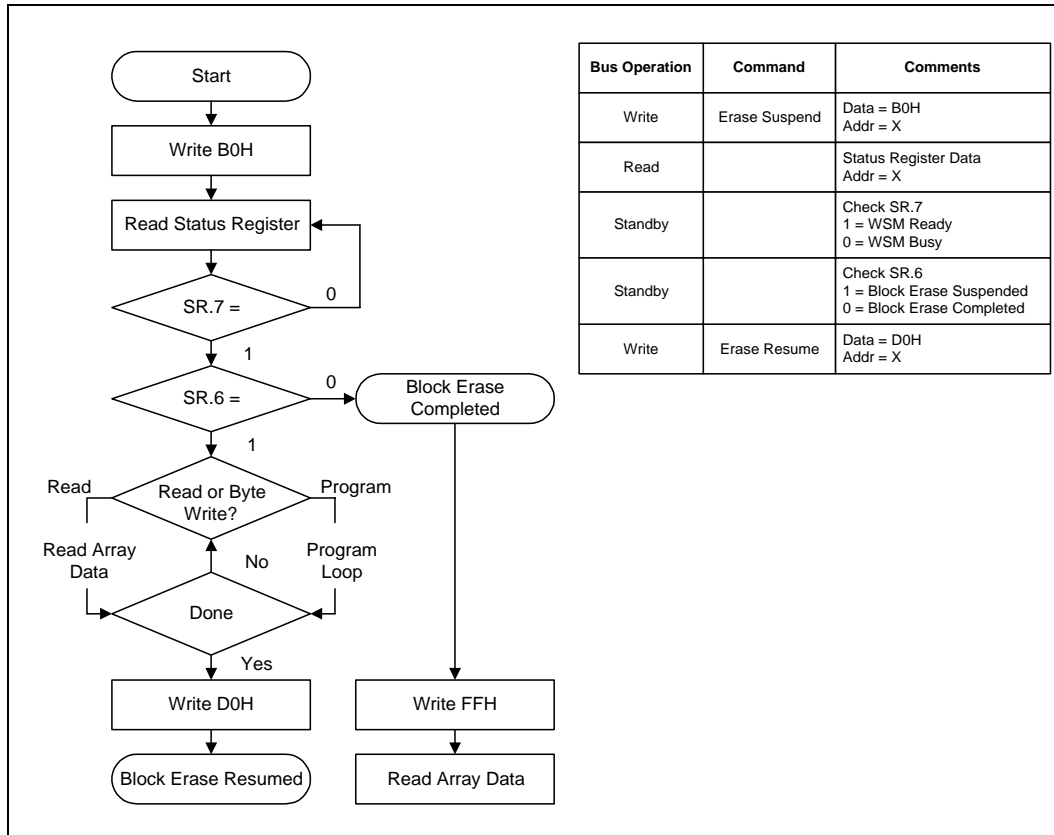

Figure 9. Block Erase Suspend/Resume Flowchart

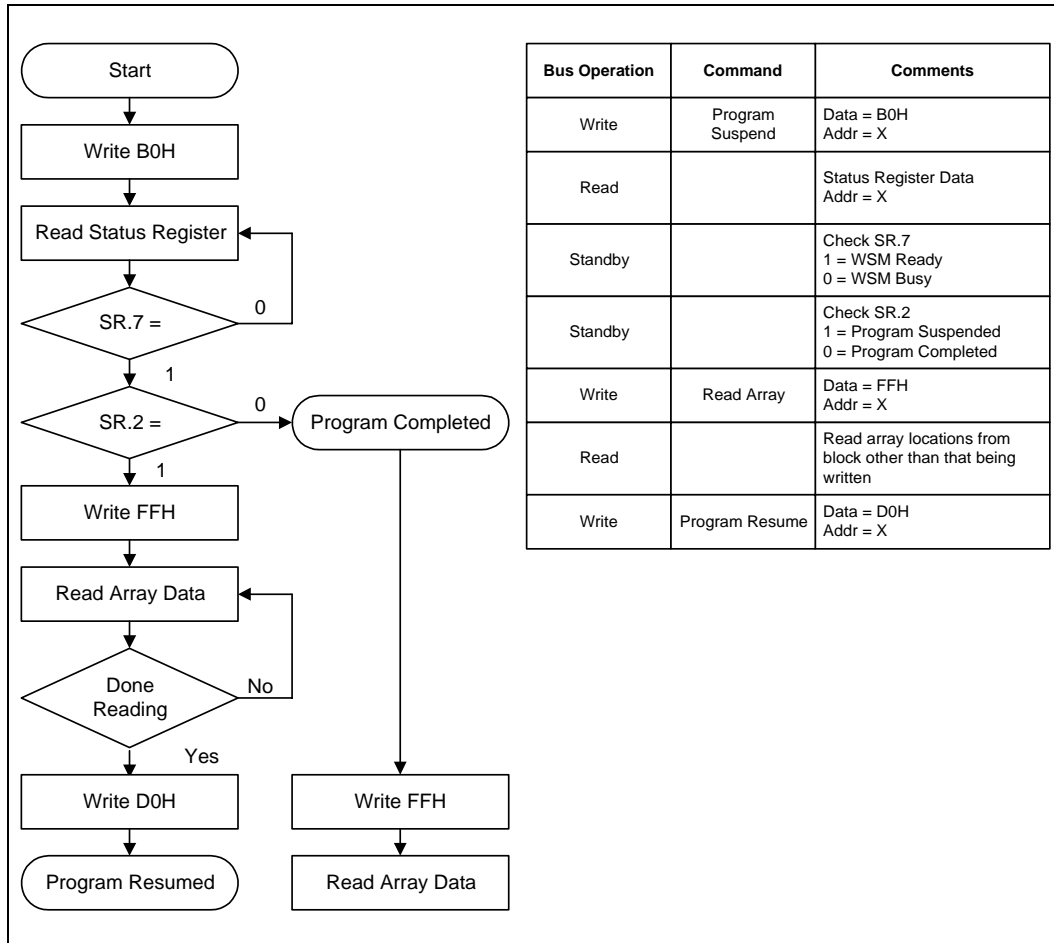

Figure 10. Program Suspend/Resume Flowchart

5.0 DATA PROTECTION

The Fast Boot Block flash memory architecture features hardware-lockable main blocks and two parameter blocks, so critical code can be kept secure while other parameter blocks are programmed or erased as necessary.

5.1 $V_{PP} \leq V_{PPLK}$ for Complete Protection

The V_{PP} programming voltage can be held low for complete write protection of all blocks in the flash device. When V_{PP} is below V_{PPLK} , any block erase or program operation will result in an error, prompting the corresponding status register bit (SR.3) to be set.

5.2 $WP\# = V_{IL}$ for Block Locking

The lockable blocks are locked when $WP\# = V_{IL}$; any block erase or program operation to a locked block will result in an error, which will be reflected in the status register. For top configuration, the top two parameter and all main blocks (blocks #37, #38, and #0 through 30 for the 16-Mbit, blocks #21, #22, and #0 through #14 for the 8-Mbit) are lockable. For the bottom configuration, the bottom two parameter and all main blocks (blocks #0, #1, and #8 through #38 for the 16-Mbit, blocks #0, #1, and #8 through #22 for the 8-Mbit) are lockable. Unlocked blocks can be programmed or erased normally (unless V_{PP} is below V_{PPLK}).

5.3 $WP\# = V_{IH}$ for Block Unlocking

$WP\#$ controls all block locking and V_{PP} provides protection against spurious writes. Table 9 defines the write protection methods.

Table 9. Write Protection Truth Table

V_{PP}	$WP\#$	$RST\#$	Write Protection Provided
X	X	V_{IL}	All Blocks Locked
V_{IL}	X	V_{IH}	All Blocks Locked
$\geq V_{PPLK}$	V_{IL}	V_{IH}	Lockable Blocks Locked
$\geq V_{PPLK}$	V_{IH}	V_{IH}	All Blocks Unlocked

26

6.0 V_{PP} VOLTAGES

Intel's Fast Boot Block flash memory family provides in-system programming and erase at 2.7 V–3.6 V (3.0 V–3.6 V for automotive temperature) V_{PP} . For customers requiring fast programming in their manufacturing environment, this family of products includes an additional low-cost, high-performance 12 V programming feature.

The 12 V V_{PP} mode enhances programming performance during short period of time typically found in manufacturing processes; however, it is not intended for extended use. 12 V may be applied to V_{PP} during block erase and program operations for a maximum of 1000 cycles on the main blocks and 2500 cycles on the parameter blocks. V_{PP} may be connected to 12 V for a total of 80 hours maximum. Stressing the device beyond these limits may cause permanent damage.

7.0 POWER CONSUMPTION

While in operation, the flash device consumes active power. However, Intel Flash devices have power savings that can significantly reduce overall system power consumption. The Automatic Power Savings (APS) feature reduces power consumption when the device is idle. If $CE\#$ is deasserted, the flash enters its standby mode, where current consumption is even lower. The combination of these features minimizes overall memory power and system power consumption.

7.1 Active Power

With $CE\#$ at a logic-low level and $RST\#$ at a logic-high level, the device is in active mode. Active power is the largest contributor to overall system power consumption. Minimizing active current has a profound effect on system power consumption, especially for battery-operated devices.

7.2 Automatic Power Savings

Automatic Power Savings (APS) provides low-power operation during active mode, allowing the flash to put itself into a low current state when not being accessed. After data is read from the memory array, the device's power consumption enters the APS mode where typical I_{CC} current is comparable to I_{CCS} . The flash stays in this static state with outputs valid until a new location is read.

7.3 Standby Power

With CE# at a logic-high level (V_{IH}) and the CUI in read mode, the flash memory is in standby mode, which disables much of the device's circuitry and substantially reduces power consumption. Outputs (DQ₀–DQ₁₅) are placed in a high-impedance state independent of the status of the OE# signal. If CE# transitions to a logic-high level during erase or program operations, the device will continue to perform the operation and consume corresponding active power until the operation is completed.

System engineers should analyze the breakdown of standby time versus active time and quantify the respective power consumption in each mode for their specific application. This will provide a more accurate measure of application-specific power and energy requirements.

7.4 Power-Up/Down Operation

The device is protected against accidental block erasure or programming during power transitions. Power supply sequencing is not required, since the device is indifferent as to which power supply, V_{PP} , V_{CC} , or V_{CCQ} , powers-up first.

7.4.1 RST# CONNECTION

The use of RST# during system reset is important with automated program/erase devices since the system expects to read from the flash memory when it comes out of reset. If a CPU reset occurs without a flash memory reset, proper CPU initialization will not occur because the flash memory may be providing status information instead of array data. Intel recommends connecting RST# to the system reset signal to allow proper CPU/flash initialization following system reset.

System designers must guard against spurious writes when V_{CC} voltages are above V_{LKO} and V_{PP} is active. Since both WE# and CE# must be low for a command write, driving either signal to V_{IH} will inhibit writes to the device. The CUI architecture provides additional protection since alteration of memory contents can only occur after successful completion of the two-step command sequences. The device is also disabled until RST# is brought to V_{IH} , regardless of the state of its control inputs. By holding the device in reset during power-up/down, invalid bus conditions during power-up can be masked, providing yet another level of memory protection.

7.4.2 V_{CC} , V_{PP} AND RST# TRANSITIONS

The CUI latches commands as issued by system software and is not altered by V_{PP} or CE# transitions or WSM actions. Its default state upon power-up, after exit from deep power-down mode or after V_{CC} transitions above V_{LKO} (Lockout voltage), is read array mode.

After any block erase or program operation is complete (even after V_{PP} transitions down to V_{PPLK}), the CUI must be reset to read array mode via the Read Array command if access to the flash memory array is desired.

7.5 Power Supply Decoupling

Flash memory's power switching characteristics require careful device decoupling. System designers should consider three supply current issues:

1. Standby current levels (I_{CCS})
2. Active current levels (I_{CCR})
3. Transient peaks produced by falling and rising edges of CE#.

Transient current magnitudes depend on the device outputs' capacitive and inductive loading. Two-line control and proper decoupling capacitor selection will suppress these transient voltage peaks. Each flash device should have a 0.1 μ F ceramic capacitor connected between each V_{CC} and GND, and between its V_{PP} and GND. These high-frequency, inherently low-inductance capacitors should be placed as close as possible to the package leads.

7.5.1 V_{PP} TRACE ON PRINTED CIRCUIT BOARDS

Designing for in-system writes to the flash memory requires special consideration of the V_{PP} power supply trace by the printed circuit board designer. The V_{PP} pin supplies the flash memory cells current for programming and erasing. V_{PP} trace widths and layout should be similar to that of V_{CC} . Adequate V_{PP} supply traces, and decoupling capacitors placed adjacent to the component, will decrease spikes and overshoots.

8.0 ELECTRICAL SPECIFICATIONS

8.1 Absolute Maximum Ratings*

Temperature under Bias -40 °C to +125 °C
 Storage Temperature..... -65 °C to +125 °C
 Voltage On Any Pin
 (except V_{CC}, V_{CCQ}, and V_{PP}) -0.5 V to +5.5 V⁽¹⁾
 V_{PP} Voltage -0.5 V to +13.5 V^(1,2,4)
 V_{CC} and V_{CCQ} Voltage -0.2 V to +5.0 V⁽¹⁾
 Output Short Circuit Current..... 100 mA⁽³⁾

NOTICE: This datasheet contains preliminary information on products in the design phase of development. The specifications are subject to change without notice. Verify with your local Intel Sales office that you have the latest datasheet before finalizing a design.

**WARNING: Stressing the device beyond the "Absolute Maximum Ratings" may cause permanent damage. These are stress ratings only. Operation beyond the "Operating Conditions" is not recommended and extended exposure beyond the "Operating Conditions" may affect device reliability.*

NOTES:

1. All specified voltages are with respect to GND. Minimum DC voltage is -0.5 V on input/output pins and -0.2 V on V_{CC} and V_{PP} pins. During transitions, this level may undershoot to -2.0 V for periods <20 ns. Maximum DC voltage on input/output pins and V_{CC} is V_{CC} +0.5 V which, during transitions, may overshoot to V_{CC} +2.0 V for periods <20 ns.
2. Maximum DC voltage on V_{PP} may overshoot to +14.0 V for periods <20 ns.
3. Output shorted for no more than one second. No more than one output shorted at a time.
4. V_{PP} Program voltage is normally 2.7 V-3.6 V. Connection to supply of 11.4 V-12.6 V can only be done for 1000 cycles on the main blocks and 2500 cycles on the parameter blocks during program/erase. V_{PP} may be connected to 12 V for a total of 80 hours maximum.

8.2 Extended Temperature Operating Conditions

Symbol	Parameter	Notes	Min	Max	Unit
T _A	Operating Temperature		-40	+85	°C
V _{CC1}	V _{CC} Supply Voltage	1	2.7	2.85	V
V _{CC2}	V _{CC} Supply Voltage	1	2.7	3.3	V
V _{CC3}	V _{CC} Supply Voltage	1,4	2.7	3.6	V
V _{CCQ1}	I/O Voltage	1,2	1.65	2.5	V
V _{CCQ2}	I/O Voltage	1,2	1.8	2.5	V
V _{CCQ3}	I/O Voltage	1,2,4	2.7	3.6	V
V _{PPH1}	V _{PP} Supply Voltage	1	2.7	3.6	V
V _{PPH2}	V _{PP} Supply Voltage	1,4	11.4	12.6	V
Cycling	Block Erase Cycling	3	10,000		Cycles

NOTES:

1. See DC Characteristics tables for voltage range-specific specifications.
2. The voltage swing on the inputs, V_{IN} is required to match V_{CCQ}.
3. Applying V_{PP} = 11.4 V-12.6 V during a program or erase can only be done for a maximum of 1000 cycles on the main blocks and 2500 cycles on the parameter blocks. A hard connection to V_{PP} = 11.4 V-12.6 V is not allowed and can cause damage to the device.
4. V_{CC}, V_{CCQ}, and V_{PP1} must share the same supply when all three are between 2.7V and 3.6 V.

8.3 Capacitance(1)

T_A = +25 °C, f = 1 MHz

Sym	Parameter	Typ	Max	Unit	Condition
C _{IN}	Input Capacitance	6	8	pF	V _{IN} = 0.0 V
C _{OUT}	Output Capacitance	8	12	pF	V _{OUT} = 0.0 V

NOTE:

1. Sampled, not 100% tested.

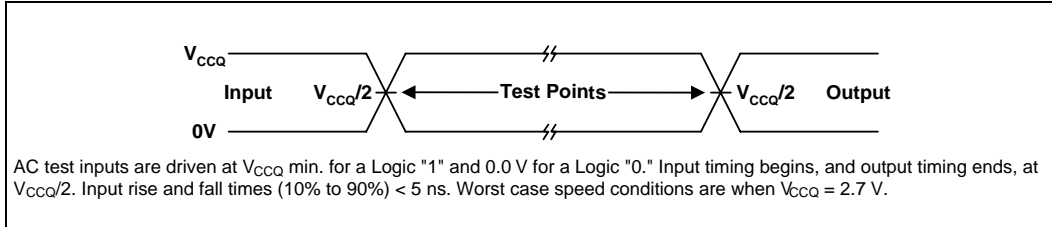
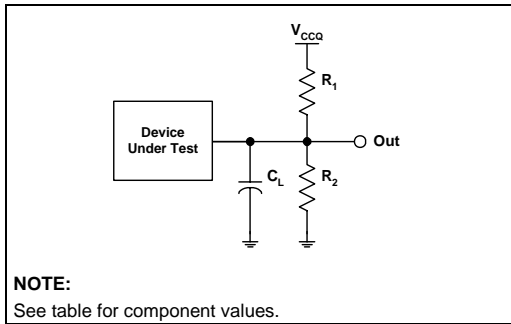

Figure 11. Transient Input/Output Reference Waveform for V_{CC} = 2.7 V–3.6 V



NOTE:

See table for component values.

Figure 12. Transient Equivalent Testing Load Circuit

Test Configuration Component Value for Worst Case Speed Conditions

Test Configuration	C _L (pF)	R ₁ (Ω)	R ₂ (Ω)
2.7 V Standard Test	50	25K	25K
1.65 V Standard Test	50	16.7K	16.7K

NOTE:

C_L includes jig capacitance.

8.4 DC Characteristics—Extended Temperature⁽¹⁾

Sym	Parameter	V _{CC}		2.7 V–3.6 V		2.7 V–2.85 V		2.7 V–3.3 V		Unit	Test Conditions
		Note	Typ	Max	Typ	Max	Typ	Max	Typ		
I _{LI}	Input Load Current	6		± 1		± 1		± 1		μA	V _{CC} = V _{CC} Max V _{CCQ} = V _{CCQ} Max V _{IN} = V _{CCQ} or GND
I _{LO}	Output Leakage Current	6		± 10		± 10		± 10		μA	V _{CC} = V _{CC} Max V _{CCQ} = V _{CCQ} Max V _{IN} = V _{CCQ} or GND
	Output Leakage Current for WAIT#			± 25		± 25		± 25			
I _{CCS}	V _{CC} Standby Current	6	30	50	20	50	150	250		μA	V _{CC} = V _{CC} Max CE# = RP# = V _{CC} or during Program/ Erase Suspend
I _{CCR}	V _{CC} Read Current	4,6	45	60	30	45	40	55		mA	Asynchronous t _{AVAV} = Min V _{IN} = V _{IH} or V _{IL}
			45	60	30	45	40	55		mA	Synchronous CLK = 33 MHz CE# = V _{IL} OE# = V _{IH} Burst length = 1
I _{CCW}	V _{CC} Program Current	3,6	8	20	8	20	8	20		mA	V _{PP} = V _{PP1, 2} Program in Progress
I _{CCE}	V _{CC} Erase Current	3,6	8	20	8	20	8	20		mA	V _{PP} = V _{PP1, 2} Erase in Progress
I _{PPR}	V _{PP} Read Current		2	±15	2	±15	2	±15		μA	V _{PP} ≤ V _{CC}
		3	50	200	50	200	50	200		μA	V _{PP} > V _{CC}
I _{PPW}	V _{PP} Program Current	3	10	35	10	35	10	35		mA	V _{PP} = V _{PP1} Program in Progress
			2	10	2	10	2	10		mA	V _{PP} = V _{PP2} Program in Progress
I _{PPE}	V _{PP} Erase Current	3	12	25	13	25	13	25		mA	V _{PP} = V _{PP1} Program in Progress
			8	25	8	25	8	25		mA	V _{PP} = V _{PP2} Program in Progress
I _{PPES} I _{PPWS}	V _{PP} Erase Suspend Current	3	50	200	50	200	50	200		μA	V _{PP} = V _{PP1, 2} Program or Erase Suspend in Progress

8.4 DC Characteristics—Extended Temperature (Continued)

Sym	Parameter	Note	V _{CC} 2.7 V–3.6 V		2.7 V–2.85 V		2.7 V–3.3 V		Unit	Test Conditions
			V _{CCQ} 2.7 V–3.6 V		1.65 V–2.5 V		1.8 V–2.5 V			
			Min	Max	Min	Max	Min	Max		
V _{IL}	Input Low Voltage		-0.4	0.4	-0.2	0.2	-0.2	0.2	V	
V _{IH}	Input High Voltage		V _{CCQ} - 0.4V		V _{CCQ} - 0.2V		V _{CCQ} - 0.2V		V	
V _{OL}	Output Low Voltage			0.10	-0.10	0.10	-0.10	0.10	V	V _{CC} = V _{CCMin} V _{CCQ} = V _{CCQMin} I _{OL} = 100 μA
V _{OH}	Output High Voltage		V _{CCQ} - 0.1V		V _{CCQ} - 0.1V		V _{CCQ} - 0.1V		V	V _{CC} = V _{CCMin} V _{CCQ} = V _{CCQMin} I _{OH} = -100 μA
V _{PPLK}	V _{PP} Lock-Out Voltage	2	1.5	1.5		1.5		1.5	V	Complete Write Protection
V _{PP1}	V _{PP} during	2	2.7	3.6					V	
V _{PP2}	Program and	2			2.7	2.85			V	
V _{PP3}	Erase Operations	2					2.7	3.3	V	
V _{PP4}		2,5	11.4	12.6	11.4	12.6	11.4	12.6	V	
V _{LKO}	V _{CC} Prog/Erase Lock Voltage		1.5		1.5		1.5		V	
V _{LKO2}	V _{CCQ} Prog/Erase Lock Voltage		1.2		1.2		1.2		V	

NOTES:

- All currents are in RMS unless otherwise noted. Typical values at normal V_{CC}, T = +25 °C.
- I_{CCES} is specified with device deselected. If device is read while in erase suspend, current draw is sum of I_{BCEs} and I_{CCR}.
- Erases and program operations are inhibited when V_{PP} ≤ V_{PPLK}, and not guaranteed outside the valid V_{PP} ranges of V_{PPH1} and V_{PPH2}.
- Sampled, not 100% tested.
- Automatic Power Savings (APS) reduces I_{CCR} to approximately standby levels, in static operation.
- Applying V_{PP} = 11.4 V–12.6 V during program/erase can only be done for a maximum of 1000 cycles on the main blocks and 2500 cycles on the parameter blocks. V_{PP} may be connected to 12 V for a total of 80 hours maximum.
- The specification is the sum of V_{CC} and V_{CCQ} currents.

8.5 AC Characteristics—Read-Only Operations^(1,6)—Extended Temperature

#	Sym	Parameter	Product	-95				-120		Unit
			V _{CC}	3.0 V–3.6 V		2.7 V–3.6 V		2.7 V–3.6 V		
			Notes	Min	Max	Min	Max	Min	Max	
R1	t _{CLK}	CLK Period		15		15		15		ns
R2	t _{CH(tCL)}	CLK High (Low) Time		2.5		2.5		2.5		ns
R3	t _{CHCL}	CLK Fall (Rise) Time			5		5		5	ns
R4	t _{AVCH}	Address Valid Setup to CLK		7		7		7		ns
R5	t _{VLCH}	ADV# Low Setup to CLK		7		7		7		ns
R6	t _{ELCH}	CE# Low Setup to CLK		7		7		7		ns
R7	t _{CHQV}	CLK to Output Delay			14		16		23	ns
R8	t _{CHQX}	Output Hold from CLK		5		5		5		ns
R9	t _{CHAX}	Address Hold from CLK	3	10		10		10		ns
R10	t _{CHTL}	CLK to WAIT# delay	5		13		16		23	ns
R11	t _{AVVH}	Address Setup to ADV# High		10		10		10		ns
R12	t _{ELVH}	CE# Low to ADV# High		10		10		10		ns
R13	t _{AVQV}	Address to Output Delay			90		95		120	ns
R14	t _{ELQV}	CE# Low to Output Delay	2		90		95		120	ns
R15	t _{VLQV}	ADV# Low to Output Delay			90		95		120	ns
R16	t _{VLVH}	ADV# Pulse Width Low		10		10		10		ns
R17	t _{VHVL}	ADV# Pulse Width High	4	10		10		10		ns
R18	t _{VHAX}	Address Hold from ADV# High	3	3		3		3		ns
R19	t _{APA}	Page Address Access Time			21		23		30	ns
R20	t _{GLQV}	OE# Low to Output Delay			25		25		30	ns
R21	t _{RHQV}	RST# High to Output Delay			600		600		600	ns
R22	t _{EHQZ} t _{GHQZ}	CE# or OE# High to Output in High Z, Whichever Occurs First	4		25		25		25	ns
R23	t _{OH}	Output Hold from Address, CE#, or OE# Change, Whichever Occurs First	4	0		0		0		ns

NOTES:

1. See AC Input/Output Reference Waveform for timing measurements and maximum allowable input slew rate.
2. OE# may be delayed up to t_{ELQV}–t_{GLQV} after the falling edge of CE# without impact on t_{ELQV}.
3. Address hold in synchronous burst-mode is defined as t_{CHAX} or t_{VHAX}, whichever timing specification is satisfied first.
4. Sampled, not 100% tested.
5. Output loading on WAIT# equals 15 pF.
6. Data bus voltage must be less than or equal to V_{CCQ} when a read operation is initiated to guarantee AC specifications.

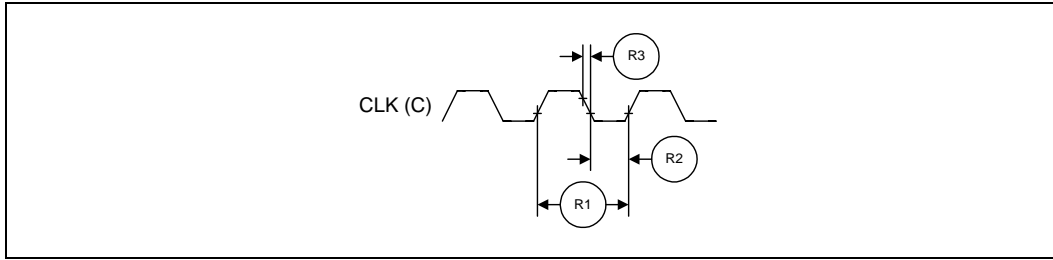

Figure 13. AC Waveform for CLK Input

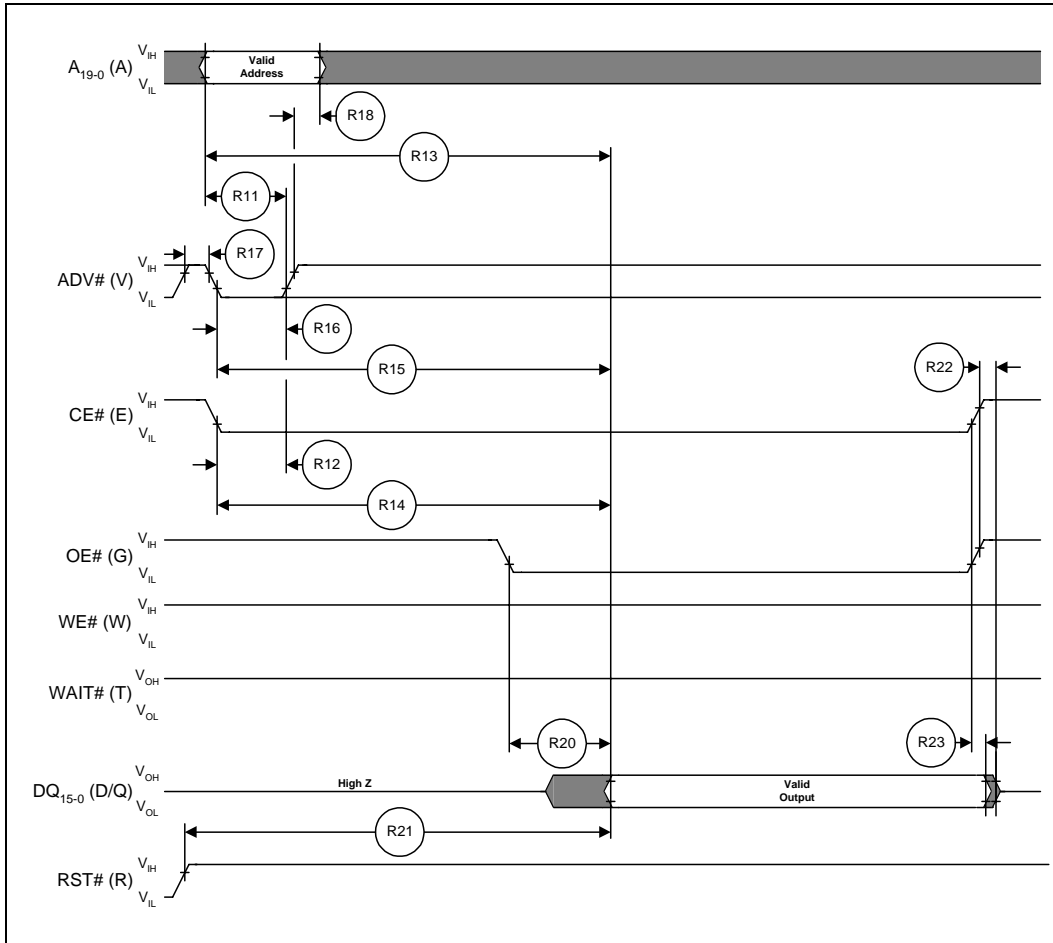

Figure 14. AC Waveform for Single Asynchronous Read Operation from Parameter Blocks, Status Register, Identifier Codes

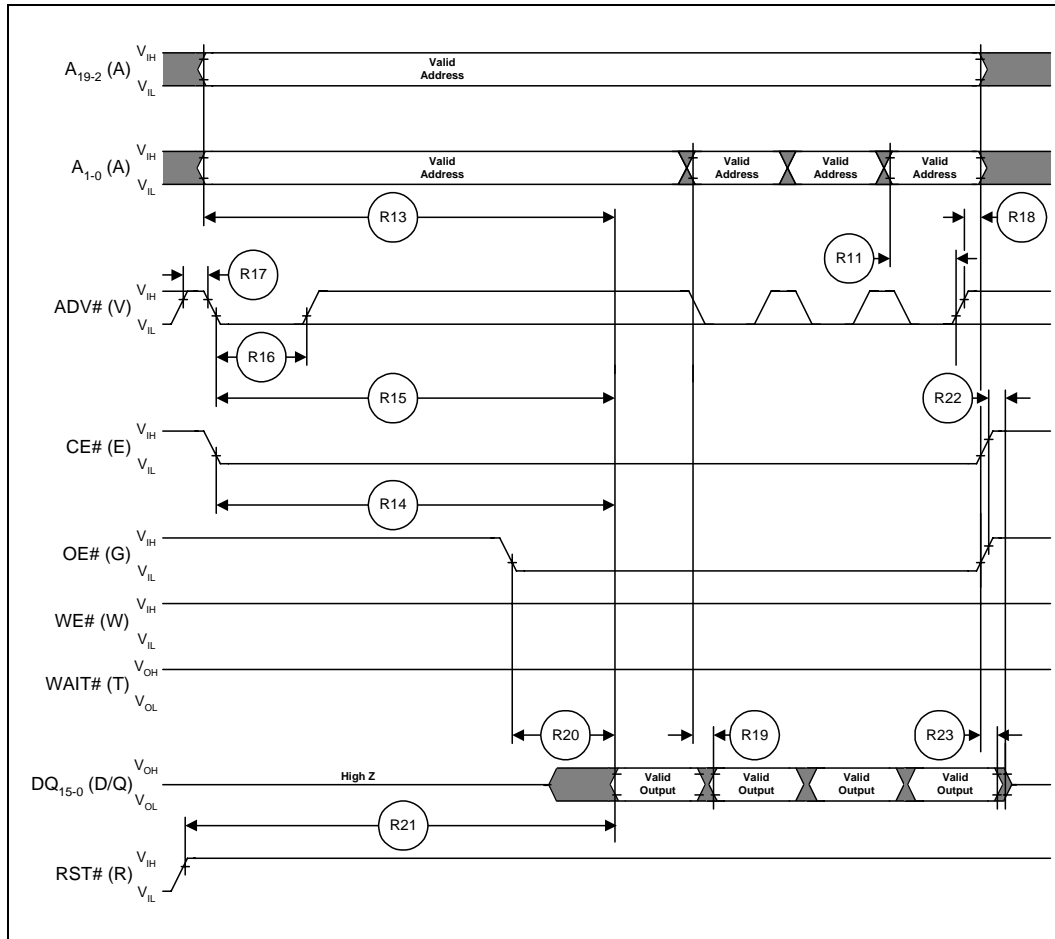

Figure 15. AC Waveform for Asynchronous Page-Mode Read Operations from Main Blocks

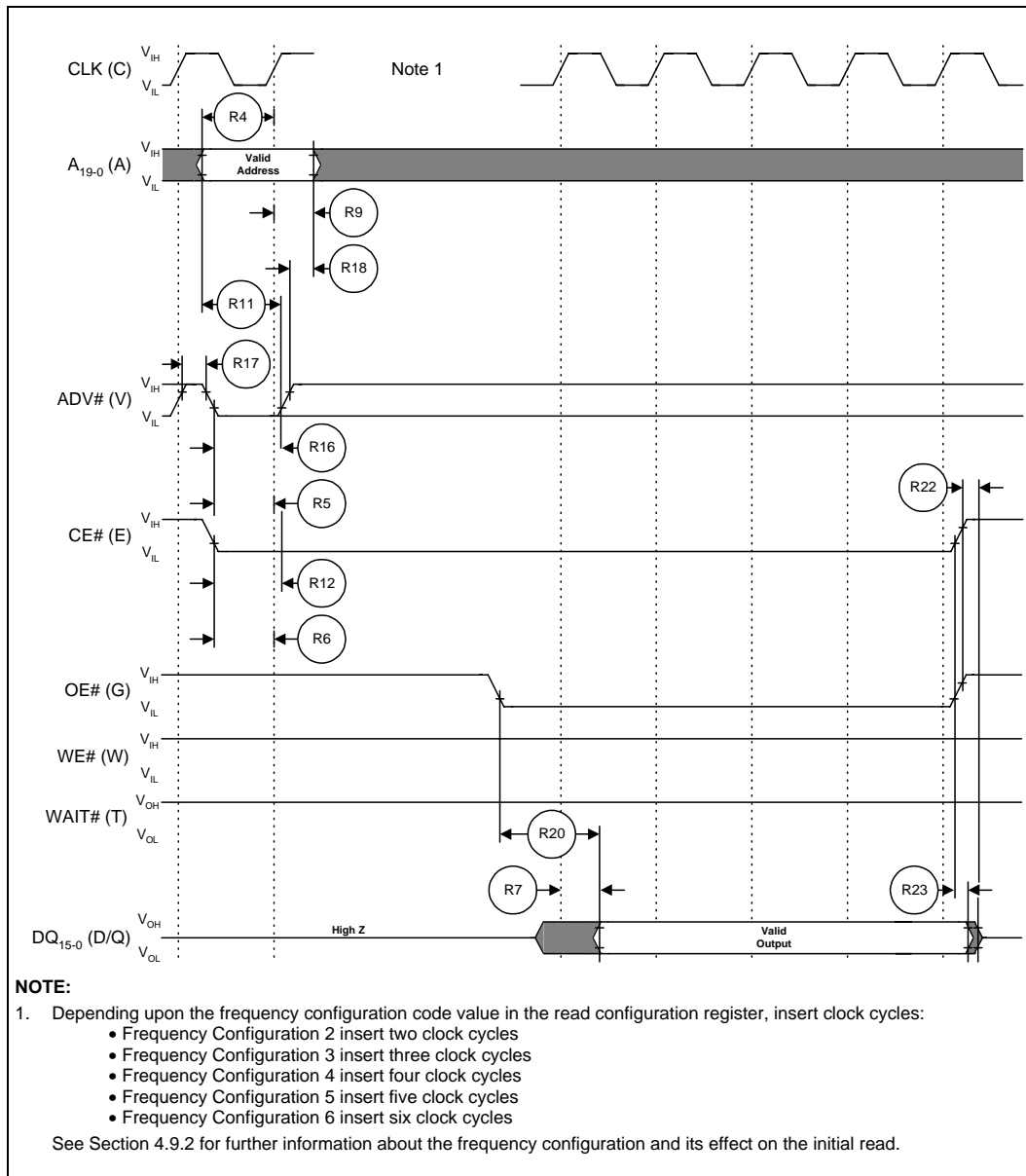

Figure 16. AC Waveform for Single Synchronous Read Operations from Parameter Blocks, Status Register, Identifier Codes

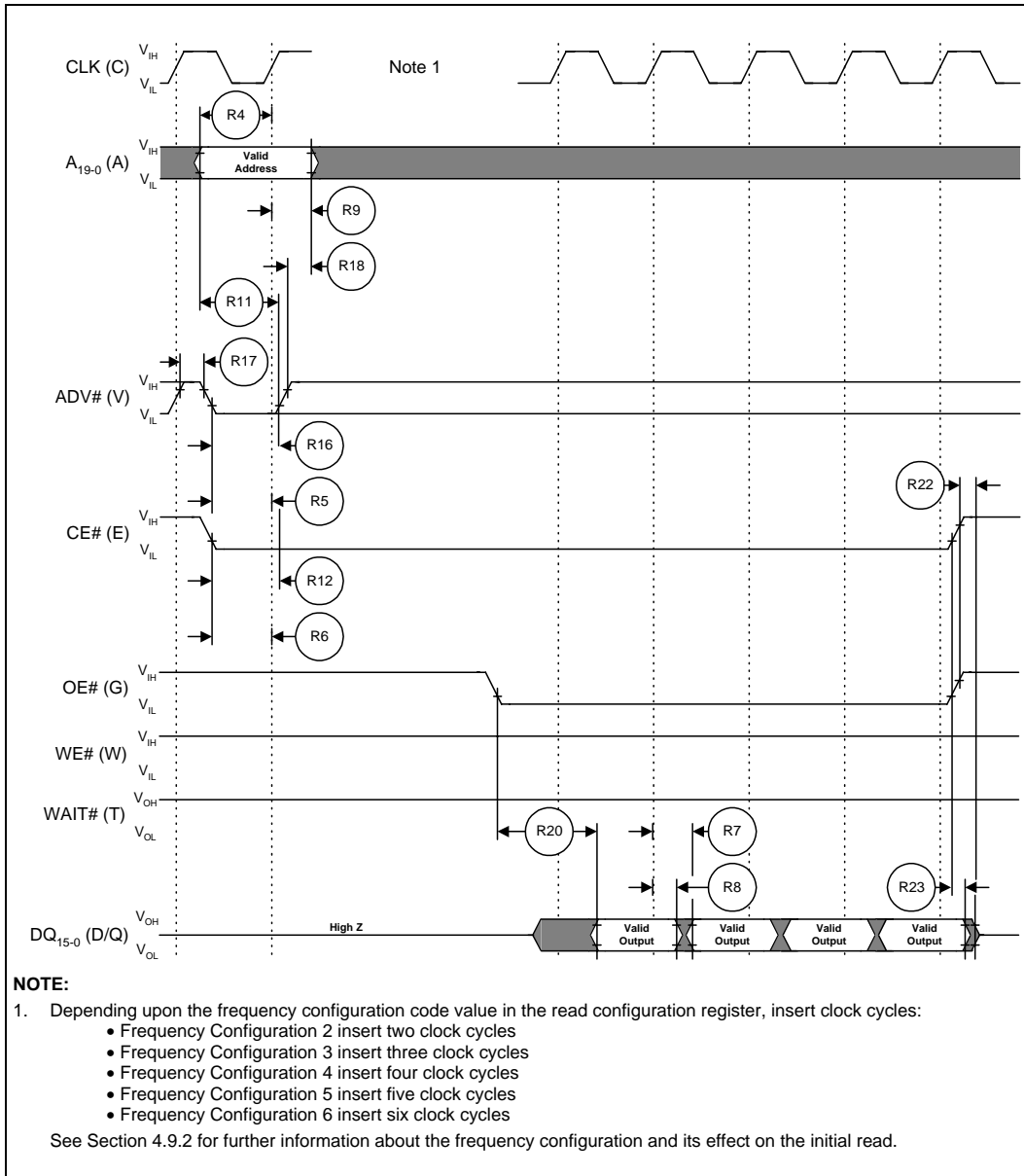

Figure 17. AC Waveform for Synchronous Burst Read Operations, Four Word Burst Length, from Main Blocks

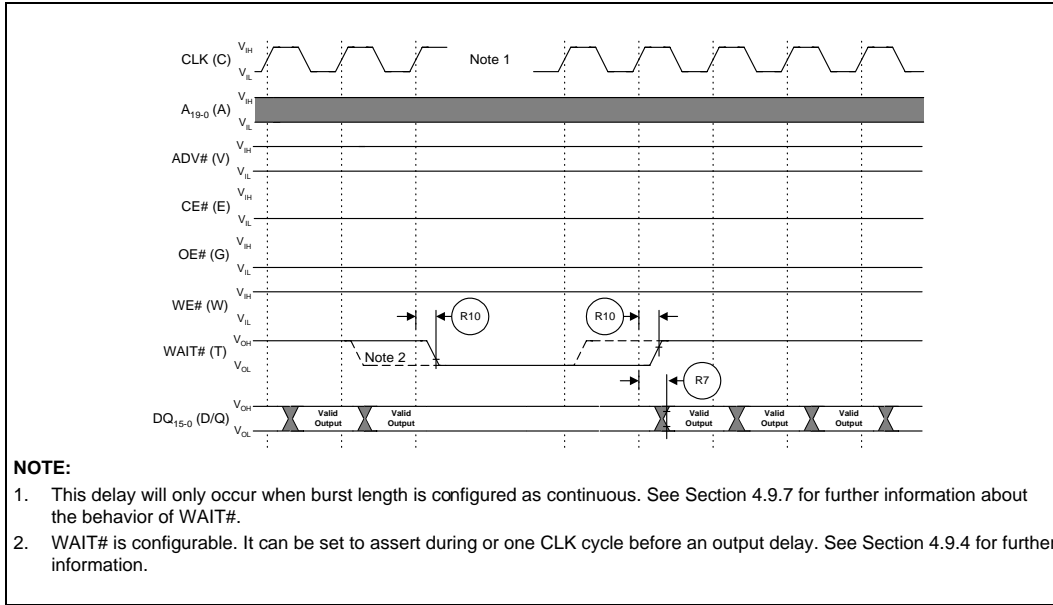

Figure 18. AC Waveform for Continuous Burst Read, Showing an Output Delay with Data Output Configuration Set to One Clock

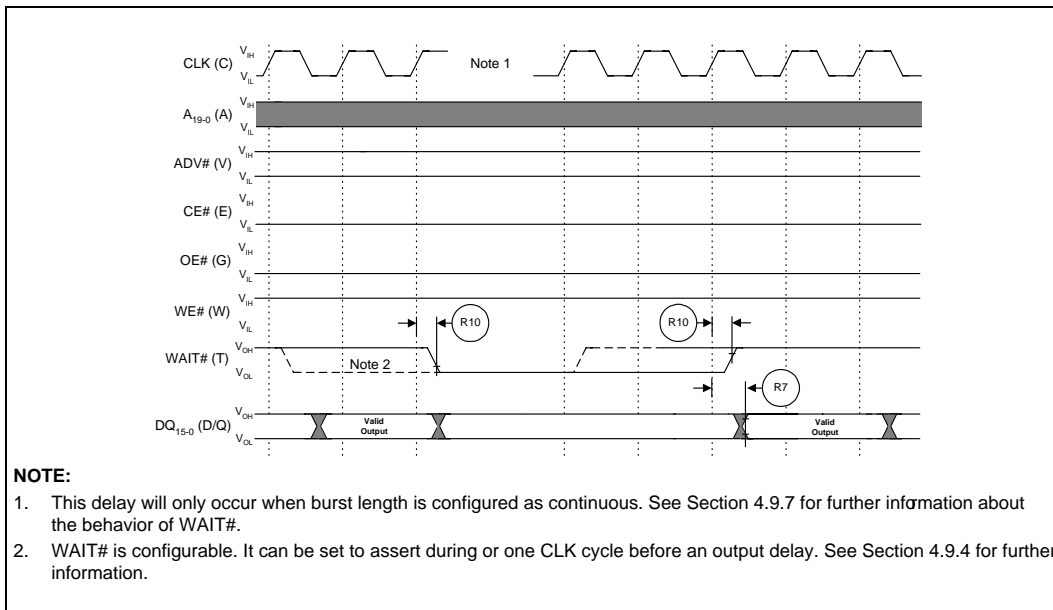

Figure 19. AC Waveform for Continuous Burst Read, Showing an Output Delay with Data Output Configuration Set to One Clock

8.6 AC Characteristics—Write Operations^(1, 2)—Extended Temperature

#	Sym	Parameter	Valid for All Speed and Voltage Combinations			Unit
			Notes	Min	Max	
W1	t _{PHWL} (t _{PHEL})	RST# High Recovery to WE# (CE#) Going Low	3	600		μs
W2	t _{ELWL} (t _{WLEL})	CE# (WE#) Setup to WE# (CE#) Going Low	6	0		ns
W3	t _{WP}	Write Pulse Width	6	75		ns
W4	t _{LVH}	ADV# Pulse Width		10		ns
W5	t _{DVWH} (t _{DVEH})	Data Setup to WE# (CE#) Going High	4	70		ns
W6	t _{AVWH} (t _{AVEH})	Address Setup to WE# (CE#) Going High	4	75		ns
W7	t _{VLEH} (t _{VLWH})	ADV# Setup to WE# (CE#) Going High		75		ns
W8	t _{AVVH}	Address Setup to ADV# Going High		10		ns
W9	t _{WHEH} (t _{EHWH})	CE# (WE#) Hold from WE# (CE#) High		0		ns
W10	t _{WHDX} (t _{EHDX})	Data Hold from WE# (CE#) High		0		ns
W11	t _{WHAX} (t _{EHAX})	Address Hold from WE# (CE#) High		0		ns
W12	t _{VHAX}	Address Hold from ADV# Going High		3		ns
W13	t _{WPH}	Write Pulse Width High	7	20		ns
W14	t _{PHWH} (t _{PHHEH})	WP# Setup to WE# (CE#) Going High	3	200		ns
W15	t _{VPWH} (t _{VPEH})	V _{PP} Setup to WE# (CE#) Going High	3	200		ns
W16	t _{WHGL} (t _{EHGL})	Write Recovery before Read		0		ns
W17	t _{QVBH}	WP# Hold from Valid SRD	3,5	0		ns
W18	t _{QVVL}	V _{PP} Hold from Valid SRD	3,5	0		ns

NOTES:

- Read timing characteristics during block erase and program operations are the same as during read-only operations. Refer to *AC Characteristics—Read-Only Operations*.
- A write operation can be initiated and terminated with either CE# or WE#.
- Sampled, not 100% tested.
- Refer to Table 3 for valid A_{IN} and D_{IN} for block erase or program.
- V_{PP} should be held at V_{PPH1/2} until determination of block erase or program success.
- Write pulse width (t_{WP}) is defined from CE# or WE# going low (whichever goes low last) to CE# or WE# going high (whichever goes high first). Hence, t_{WP} = t_{WLWH} = t_{LEH} = t_{WLEH} = t_{ELWH}.
- Write pulse width high (t_{WPH}) is defined from CE# or WE# going high (whichever goes high first) to CE# or WE# going low (whichever goes low last). Hence, t_{WPH} = t_{WHWL} = t_{EHEL} = t_{WHEL} = t_{EHWL}.

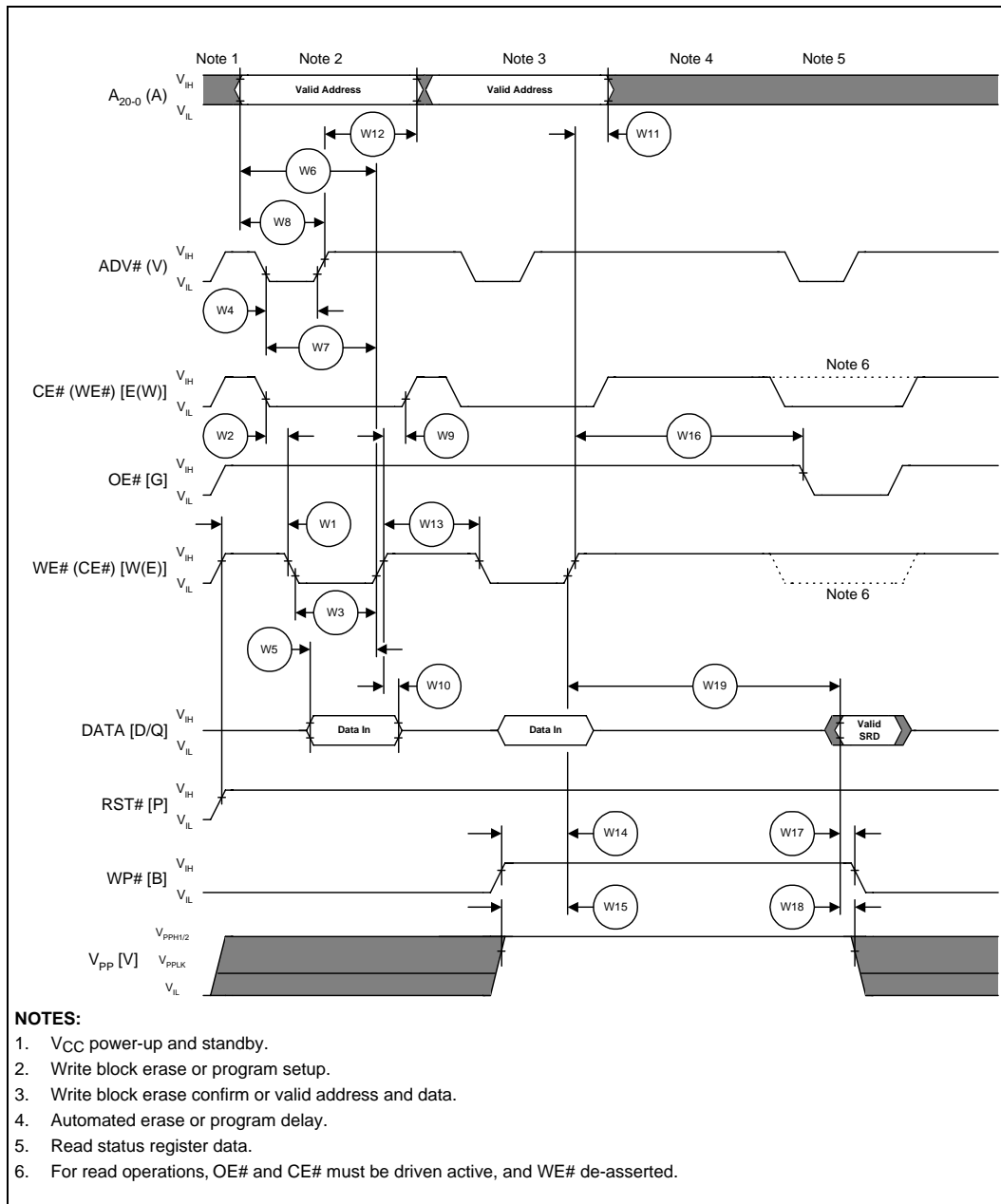

Figure 20. AC Waveform for Write Operations

8.7 AC Characteristics—Reset Operation—Extended Temperature

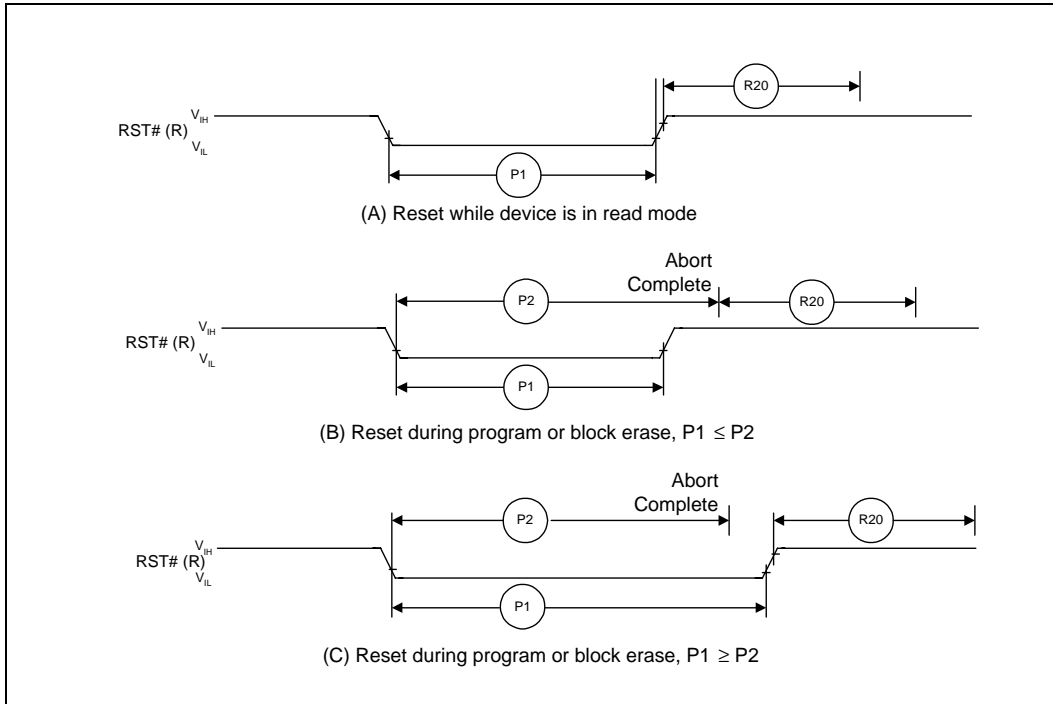

Figure 21. AC Waveform for Reset Operation

Table 10. Reset Specifications

#	Symbol	Parameter	Notes	Min	Max	Unit
P1	t_{PLPH}	RST# Low to Reset During Read (If RST# is tied to V_{CC} , this specification is not applicable)	2,4	100		ns
P2	t_{PLRH}	RST# Low to Reset during Block Erase or Program	3,4		22	μ s

NOTES:

1. These specifications are valid for all product versions (packages and speeds).
2. If t_{PLPH} is < 100 ns the device may still reset but this is not guaranteed.
3. If RST# is asserted while a block erase or word program operation is not executing, the reset will complete within 100 ns.
4. Sampled, but not 100% tested.

8.8 Extended Temperature Block Erase And Program Performance^(3, 4, 5)

#	Sym	Parameter	Notes	2.7 V V _{PP}		12 V V _{PP}		Unit
				Typ ⁽¹⁾	Max	Typ ⁽¹⁾	Max	
W19	t _{WHRH1} ,	Program Time	2	23.5	200	8	185	μs
	t _{EHRH1}	Block Program Time (Parameter)	2	0.10	0.30	0.03	0.10	sec
		Block Program Time (Main)	2	0.8	2.4	0.24	0.8	sec
	t _{WHRH2} ,	Block Erase Time (Parameter)	2	1	4	0.8	4	sec
	t _{EHRH2}	Block Erase Time (Main)	2	1.8	5	1.1	5	sec
		Program Suspend Latency		6	10	5	10	μs
	t _{WHRH5} ,	Program Suspend Latency		6	10	5	10	μs
	t _{EHRH5}	Program Suspend Latency		6	10	5	10	μs
	t _{WHRH6} ,	Erase Suspend Time		13	20	10	12	μs
	t _{EHRH6}	Erase Suspend Time		13	20	10	12	μs

NOTES:

1. Typical values measured at T_A = +25 °C and nominal voltages. Subject to change based on device characterization.
2. Excludes system-level overhead.
3. These performance numbers are valid for all speed versions.
4. Sampled, but not 100% tested.
5. Reference the *AC Waveform for Write Operations* Figure 20.

8.9 Automotive Temperature Operating Conditions

Except for the specifications given in this section, all DC and AC characteristics are identical to those listed in the extended temperature specifications. See Section 7.2 for extended temperature specifications.

Symbol	Parameter	Notes	Min	Max	Unit
T _A	Operating Temperature		-40	+125	°C
V _{CC1}	V _{CC} Supply Voltage	1	3.0	3.6	V
V _{CCQ1}	I/O Voltage	1,2	3.0	3.6	V
V _{PPH1}	V _{PP} Supply Voltage	1	3.0	3.6	V
V _{PPH2}	V _{PP} Supply Voltage	1,3	11.4	12.6	V
Cycling	Parameter Block Erase Cycling		30,000		Cycles
	Main Block Erase Cycling		1,000		Cycles

NOTES:

1. See DC Characteristics tables for voltage range-specific specifications.
2. The voltage swing on the inputs, V_{IN} is required to match V_{CCQ}.
3. Applying V_{PP} = 11.4 V–12.6 V during a program/erase can only be done for a maximum of 1000 cycles on the main and parameter blocks. A hard connection to V_{PP} = 11.4 V–12.6 V is not allowed and can cause damage to the device.

8.10 Capacitance⁽¹⁾

T_A = +25°C, f = 1 MHz

Sym	Parameter	Typ	Max	Unit	Condition
C _{IN}	Input Capacitance	6	8	pF	V _{IN} = 0.0 V
C _{OUT}	Output Capacitance	8	12	pF	V _{OUT} = 0.0 V

NOTE:

1. Sampled, not 100% tested.

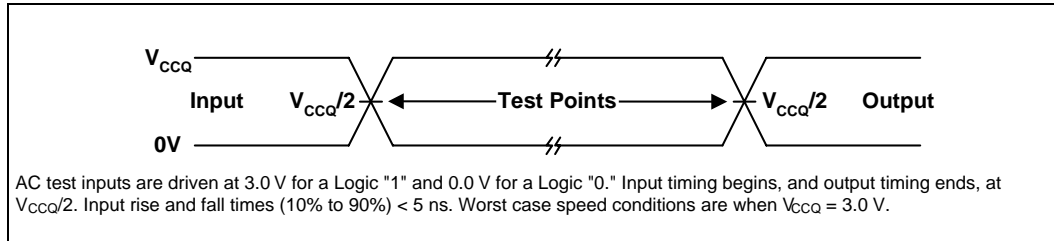
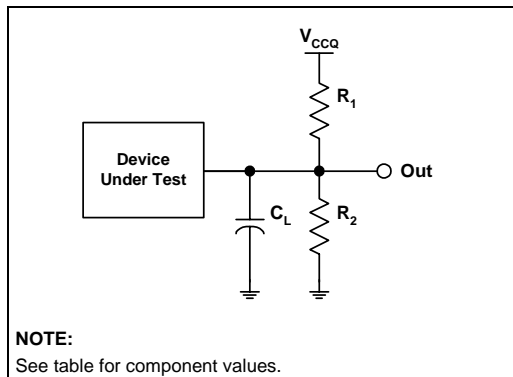

Figure 22. Transient Input/Output Reference Waveform for V_{CC} = 3.3 V ± 0.3 V



NOTE:

See table for component values.

Figure 23. Transient Equivalent Testing Load Circuit

Test Configuration Component Value for Worst Case Speed Conditions

Test Configuration	C _L (pF)	R ₁ (Ω)	R ₂ (Ω)
3 V Standard Test	80	25K	25K

NOTE:

C_L includes jig capacitance.

8.11 DC Characteristics⁽¹⁾—Automotive Temperature

Sym	Parameter	Note	Typ	Max	Unit	Test Condition
I_{CCS}	V_{CC} Standby Current	2,6	40	60	μ A	$V_{CC} = V_{CC} \text{ Max}$ $V_{CCQ} = V_{CCQ} \text{ Max}$ $CE\# = RST\# = V_{IH}$
I_{CCR}	V_{CC} Read Current	4,6	60	75	mA	Asynchronous $t_{AVAV} = \text{Min}$ $V_{CC} = V_{CC} \text{ Max}$ $V_{CCQ} = V_{CCQ} \text{ Max}$ $V_{IN} = V_{IH} \text{ or } V_{IL}$
			60	75	mA	Synchronous $CLK = 22 \text{ MHz}$ $CE\# = V_{IL}$ $OE\# = V_{IH}$ Burst length = 1
I_{CCW}	V_{CC} Program Current	3,5,7	8	20	mA	$V_{PP} = V_{PPH1} (3.0 \text{ V} - 3.6 \text{ V})$ Program in progress
			8	20	mA	$V_{PP} = V_{PPH2} (11.4 \text{ V} - 12.6 \text{ V})$ Program in progress
I_{CCE}	V_{CC} Block Erase Current	3,5,7	8	20	mA	$V_{PP} = V_{PPH1} (3.0 \text{ V} - 3.6 \text{ V})$ Block erase in progress
			8	20	mA	$V_{PP} = V_{PPH2} (11.4 \text{ V} - 12.6 \text{ V})$ Block erase in progress
I_{PPW}	V_{PP} Program Current	3,5,7	15	40	mA	$V_{PP} = V_{PPH1} (3.0 \text{ V} - 3.6 \text{ V})$ Program in progress
			10	25	mA	$V_{PP} = V_{PPH2} (11.4 \text{ V} - 12.6 \text{ V})$ Program in progress
I_{PPE}	V_{PP} Block Erase Current	3,5,7	13	25	mA	$V_{PP} = V_{PPH1} (3.0 \text{ V} - 3.6 \text{ V})$ Block erase in progress
			8	25	mA	$V_{PP} = V_{PPH2} (11.4 \text{ V} - 12.6 \text{ V})$ Block erase in progress

NOTES:

- All currents are in RMS unless otherwise noted. Typical values at normal V_{CC} , $T = +25 \text{ }^\circ\text{C}$.
- Erases and program operations are inhibited when $V_{PP} \leq V_{PPLK}$, and not guaranteed outside the valid V_{PP} ranges of V_{PPH1} and V_{PPH2} .
- Sampled, not 100% tested.
- Automatic Power Savings (APS) reduces I_{CCR} to approximately standby levels, in static operation.
- 12 V (11.4 V–12.6 V) can only be applied to V_{PP} for a maximum of 80 hours over the lifetime of the device. V_{PP} should not be permanently tied to 12 V.
- The specification is the sum of V_{CC} and V_{CCQ} currents.

8.12 AC Characteristics—Read-Only Operations⁽¹⁾—Automotive Temperature

#	Sym	Parameter	Notes	Min	Max	Unit
R1	t _{CLK}	CLK Period		15		ns
R2	t _{CH} (t _{CL})	CLK High (Low) Time		2.5		ns
R3	t _{CHCL} (t _{CLCH})	CLK Fall (Rise) Time			5	ns
R4	t _{AVCH}	Address Valid Setup to CLK		17		ns
R5	t _{VLCH}	ADV# Low Setup to CLK		17		ns
R6	t _{ELCH}	CE# Low Setup to CLK		17		ns
R7	t _{CHQV}	CLK to Output Delay			30	ns
R8	t _{CHQX}	Output Hold from CLK		5		ns
R9	t _{CHAX}	Address Hold from CLK	3	10		ns
R10	t _{CHTL} (t _{CHTH})	CLK to WAIT# delay	5		30	ns
R11	t _{AVVH}	Address Setup to ADV# Going High		19		ns
R12	t _{ELVH}	CE# Low to ADV# Going High		19		ns
R13	t _{AVQV}	Address to Output Delay			150	ns
R14	t _{ELQV}	CE# Low to Output Delay	2		150	ns
R15	t _{VLQV}	ADV# Low to Output Delay			150	ns
R16	t _{VLVH}	ADV# Pulse Width		19		ns
R17	t _{VHVL}	ADV# Pulse Width		19		ns
R18	t _{VHAX}	Address Hold from ADV# Going High	3	3		ns
R19	t _{APA}	Page Address Access Time			35	ns
R20	t _{GLQV}	OE# Low to Output Delay			50	ns
R21	t _{RHQV}	RST# High to Output Delay			600	ns
R22	t _{EHQZ} t _{GHQZ}	CE# or OE# High to Output in High Z, Whichever Occurs First	4		40	ns
R23	t _{OH}	Output Hold from Address, CE#, or OE# Change, Whichever Occurs First	4	0		ns

NOTES:

1. See AC Input/Output Reference Waveform for timing measurements and maximum allowable input slew rate.
2. OE# may be delayed up to t_{ELQV}-t_{GLQV} after the falling edge of CE# without impact on t_{ELQV}.
3. Sampled, not 100% tested.
4. Output loading on WAIT# equals 15 pF.

8.13 Automotive Temperature Frequency Configuration Settings

Table 11. Frequency Configuration Settings for Automotive Temperature Components

Frequency Configuration Code	Input CLK Frequency
1	Reserved
2	≤ 22 MHz
3	≤ 33 MHz
4	≤ 40 MHz
5	≤ 50 MHz
6	≤ 66 MHz

8.14 Automotive Temperature Block Erase and Program Performance^(3,4,5)

#	Sym	Parameter	Notes	3.3 V V _{PP}		12 V V _{PP}		Unit
				Typ ⁽¹⁾	Max	Typ ⁽¹⁾	Max	
W19	t _{WHRH1} , t _{EHRH1}	Program Time	2	23.5	TDB	8	TDB	μs
		Block Program Time (Parameter)	2	0.10	TDB	0.03	TDB	sec
		Block Program Time (Main)	2	0.8	TDB	0.24	TDB	sec
	t _{WHRH2} , t _{EHRH2}	Block Erase Time (Parameter)	2	1	TDB	0.8	TDB	sec
		Block Erase Time (Main)	2	1.8	TDB	1.1	TDB	sec
	t _{WHRH5} , t _{EHRH5}	Program Suspend Latency		6	TDB	5	TDB	μs
t _{WHRH6} , t _{EHRH6}	Erase Suspend Time		13	TDB	10	TDB	μs	

NOTES:

1. Typical values measured at T_A = +25°C and nominal voltages. Subject to change based on device characterization.
2. Excludes system-level overhead.
3. These performance numbers are valid for all speed versions.
4. Sampled, but not 100% tested.
5. Reference the *AC Waveform for Write Operations* Figure 20.

9.0 ORDERING INFORMATION

D	T	2	8	F	1	6	0	F	3	T	1	2	0
---	---	---	---	---	---	---	---	---	---	---	---	---	---

Package
 DT = Extended temp., 56-Lead SSOP
 DE = Automotive temp., 56-Lead SSOP
 GT = Extended temp., 56-Ball μBGA* CSP

Product line designator
 for all Intel Flash products

Device Density
 160 = x16 (16-Mbit)
 800 = x16 (8-Mbit)

Access Speed (ns)
 (95,120,150)

T = Top Blocking
B = Bottom Blocking

Product Family
 F3 = Fast Boot Block
 V_{CC} = 2.7V - 3.6V
 V_{PP} = 2.7V - 3.6V or 11.4V - 12.6V

VALID COMBINATIONS

		56-Lead SSOP	56-Ball μBGA CSP⁽¹⁾
Extended	16M	DT28F160F3T120	GT28F160F3T120
		DT28F160F3B120	GT28F160F3B120
		DT28F160F3T95	GT28F160F3T95
		DT28F160F3B95	GT28F160F3B95
Extended	8M	DT28F800F3T120	GT28F800F3T120
		DT28F800F3B120	GT28F800F3B120
		DT28F800F3T95	GT28F800F3T95
		DT28F800F3B95	GT28F800F3B95
Automotive	8M	DE28F800B3T150 DE28F800B3B150	

NOTE:

- The 56-Ball μBGA package top side mark reads F160F3 [or F800F3]. All product shipping boxes or trays provide the correct information regarding bus architecture.

10.0 ADDITIONAL INFORMATION(1,2)

Order Number	Document/Tool
210830	<i>Flash Memory Databook</i>
292213	<i>AP-655 Fast Boot Block Design Guide</i>
Contact Intel/Distribution Sales Office	Fast Boot Block CPU Design Guide
297846	<i>Comprehensive User's Guide for μBGA* Package</i>
See Intel's World Wide Web Home Page	Micro Ball Grid Array Package Mechanical Specification and Media Information

NOTES:

1. Please call the Intel Literature Center at (800) 548-4725 to request Intel documentation. International customers should contact their local Intel or distribution sales office.
2. Visit Intel's World Wide Web home page at <http://www.intel.com> for technical documentation and tools.

This datasheet has been downloaded from:

www.DatasheetCatalog.com

Datasheets for electronic components.



LittleDiode supplies new, hard to find or obsolete electronic components and semiconductors all over the world.

With over two million different components listed you are sure to find the part you need.

Feel free to visit us today at our online store:

LittleDiode.com

Looking forward to providing you with the best possible service.