



# 3 Volt Intel® StrataFlash™ Memory

28F128J3A, 28F640J3A, 28F320J3A (x8/x16)

## Preliminary Datasheet

### Product Features

- High-Density Symmetrically-Blocked Architecture
  - 128 128-Kbyte Erase Blocks (128 M)
  - 64 128-Kbyte Erase Blocks (64 M)
  - 32 128-Kbyte Erase Blocks (32 M)
- High Performance Interface Asynchronous Page Mode Reads
  - 110/25 ns Read Access Time (32 M)
  - 120/25 ns Read Access Time (64 M)
  - 150/25 ns Read Access Time (128 M)
- 2.7 V–3.6 V  $V_{CC}$  Operation
- 128-bit Protection Register
  - 64-bit Unique Device Identifier
  - 64-bit User Programmable OTP Cells
- Enhanced Data Protection Features Absolute Protection with  $V_{PEN} = GND$ 
  - Flexible Block Locking
  - Block Erase/Program Lockout during Power Transitions
- Packaging
  - 56-Lead TSOP Package
  - 64-Ball Intel® Easy BGA Package
- Cross-Compatible Command Support Intel Basic Command Set
  - Common Flash Interface
  - Scalable Command Set
- 32-Byte Write Buffer
  - 6  $\mu$ s per Byte Effective Programming Time
- 12.8M Total Min. Erase Cycles (128 Mbit)  
6.4M Total Min. Erase Cycles (64 Mbit)  
3.2M Total Min. Erase Cycles (32 Mbit)
  - 100K Minimum Erase Cycles per Block
- Automation Suspend Options
  - Block Erase Suspend to Read
  - Block Erase Suspend to Program
  - Program Suspend to Read
- 0.25  $\mu$  Intel® StrataFlash™ Memory Technology

Capitalizing on Intel's 0.25  $\mu$  generation two-bit-per-cell technology, second generation Intel® StrataFlash™ memory products provide 2X the bits in 1X the space, with new features for mainstream performance. Offered in 128-Mbit (16-Mbyte), 64-Mbit, and 32-Mbit densities, these devices bring reliable, two-bit-per-cell storage technology to the flash market segment.

Benefits include: more density in less space, high-speed interface, lowest cost-per-bit NOR devices, support for code and data storage, and easy migration to future devices.

Using the same NOR-based ETOX™ technology as Intel's one-bit-per-cell products, Intel StrataFlash memory devices take advantage of over one billion units of manufacturing experience since 1987. As a result, Intel StrataFlash components are ideal for code and data applications where high density and low cost are required. Examples include networking, telecommunications, digital set top boxes, audio recording, and digital imaging.

By applying FlashFile™ memory family pinouts, Intel StrataFlash memory components allow easy design migrations from existing Word-Wide FlashFile memory (28F160S3 and 28F320S3), and first generation Intel StrataFlash memory (28F640J5 and 28F320J5) devices.

Intel StrataFlash memory components deliver a new generation of forward-compatible software support. By using the Common Flash Interface (CFI) and the Scalable Command Set (SCS), customers can take advantage of density upgrades and optimized write capabilities of future Intel StrataFlash memory devices.

Manufactured on Intel® 0.25 micron ETOX™ VI process technology, Intel StrataFlash memory provides the highest levels of quality and reliability.

---

**Notice:** This document contains preliminary information on new products in production. The specifications are subject to change without notice. Verify with your local Intel sales office that you have the latest datasheet before finalizing a design.

---



Information in this document is provided in connection with Intel® products. No license, express or implied, by estoppel or otherwise, to any intellectual property rights is granted by this document. Except as provided in Intel's Terms and Conditions of Sale for such products, Intel assumes no liability whatsoever, and Intel disclaims any express or implied warranty, relating to sale and/or use of Intel products including liability or warranties relating to fitness for a particular purpose, merchantability, or infringement of any patent, copyright or other intellectual property right. Intel products are not intended for use in medical, life saving, or life sustaining applications.

Intel may make changes to specifications and product descriptions at any time, without notice.

Designers must not rely on the absence or characteristics of any features or instructions marked "reserved" or "undefined." Intel reserves these for future definition and shall have no responsibility whatsoever for conflicts or incompatibilities arising from future changes to them.

The 28F128J3A, 28F640J3A, 28F320J3A may contain design defects or errors known as errata which may cause the product to deviate from published specifications. Current characterized errata are available on request.

Contact your local Intel sales office or your distributor to obtain the latest specifications and before placing your product order.

Copies of documents which have an ordering number and are referenced in this document, or other Intel literature may be obtained by calling 1-800-548-4725 or by visiting Intel's website at <http://www.intel.com>.

Copyright © Intel Corporation, 1999–2001

\*Other names and brands may be claimed as the property of others.

**Preliminary**

# Contents

---

<b>1.0</b>	<b>Product Overview</b> .....	1
<b>2.0</b>	<b>Principles of Operation</b> .....	6
	2.1 Data Protection.....	6
<b>3.0</b>	<b>Bus Operations</b> .....	7
	3.1 Read.....	8
	3.2 Output Disable.....	8
	3.3 Standby .....	8
	3.4 Reset/Power-Down .....	8
	3.5 Read Query .....	9
	3.6 Read Identifier Codes.....	9
	3.7 Write .....	9
<b>4.0</b>	<b>Command Definitions</b> .....	9
	4.1 Read Array Command.....	13
	4.2 Read Query Mode Command .....	13
	4.2.1 Query Structure Output .....	13
	4.2.2 Query Structure Overview .....	14
	4.2.3 Block Status Register .....	15
	4.2.4 CFI Query Identification String .....	15
	4.2.5 System Interface Information .....	16
	4.2.6 Device Geometry Definition.....	17
	4.2.7 Primary-Vendor Specific Extended Query Table.....	18
	4.3 Read Identifier Codes Command .....	19
	4.4 Read Status Register Command.....	20
	4.5 Clear Status Register Command.....	22
	4.6 Block Erase Command.....	22
	4.7 Block Erase Suspend Command .....	22
	4.8 Write to Buffer Command.....	23
	4.9 Byte/Word Program Commands .....	24
	4.10 Program Suspend Command.....	24
	4.11 Set Read Configuration Command .....	24
	4.11.1 Read Configuration .....	25
	4.12 Configuration Command .....	25
	4.13 Set Block Lock-Bit Commands .....	26
	4.14 Clear Block Lock-Bits Command.....	27
	4.15 Protection Register Program Command .....	27
	4.15.1 Reading the Protection Register .....	27
	4.15.2 Programming the Protection Register .....	27
	4.15.3 Locking the Protection Register .....	28
<b>5.0</b>	<b>Design Considerations</b> .....	38
	5.1 Three-Line Output Control.....	38
	5.2 STS and Block Erase, Program, and Lock-Bit Configuration Polling .....	38
	5.3 Power Supply Decoupling .....	38
	5.4 Input Signal Transitions - Reducing Overshoots and Undershoots When Using	



	Buffers or Transceivers	39
5.5	VCC, VPEN, RP# Transitions .....	39
5.6	Power-Up/Down Protection.....	39
5.7	Power Dissipation .....	40
<b>6.0</b>	<b>Electrical Specifications</b> .....	<b>40</b>
6.1	Absolute Maximum Ratings .....	40
6.2	Operating Conditions .....	41
6.3	Capacitance .....	41
6.4	DC Characteristics .....	42
6.5	AC Characteristics— Read-Only Operations <sup>(1,2)</sup> .....	45
6.6	AC Characteristics— Write Operations <sup>(1,2)</sup> .....	47
6.7	Block Erase, Program, and Lock-Bit Configuration Performance <sup>(1,2,3)</sup> .....	48
<b>7.0</b>	<b>Ordering Information</b> .....	<b>51</b>
<b>8.0</b>	<b>Additional Information</b> .....	<b>52</b>

# Revision History

Date of Revision	Version	Description
07/07/99	-001	Original Version
08/03/99	-002	A <sub>0</sub> -A <sub>2</sub> indicated on block diagram
09/07/99	-003	Changed Minimum Block Erase time, I <sub>OL</sub> , I <sub>OH</sub> , Page Mode and Byte Mode currents. Modified RP# on AC Waveform for Write Operations
12/16/99	-004	Changed Block Erase time and t <sub>AVWH</sub> Removed all references to 5 V I/O operation Corrected <i>Ordering Information</i> , <i>Valid Combinations</i> entries Changed Min program time to 211 μs Added DU to Lead Descriptions table Changed Chip Scale Package to Ball Grid Array Package Changed default read mode to page mode Removed erase queuing from Figure 10, <i>Block Erase Flowchart</i>
03/16/00	-005	Added Program Max time Added Erase Max time Added Max page mode read current Moved tables to correspond with sections Fixed typographical errors in ordering information and DC parameter table Removed V <sub>CCQ1</sub> setting and changed V <sub>CCQ2/3</sub> to V <sub>CCQ1/2</sub> Added recommended resistor value for STS pin Change operation temperature range Removed note that rp# could go to 14 V Removed V <sub>OL</sub> of 0.45 V Removed V <sub>OH</sub> of 2.4 V Updated I <sub>CCR</sub> Typ values Added Max lock-bit program and lock times Added note on max measurements
06/26/00	-006	Updated cover sheet statement of 700 million units to one billion. Corrected Table 10 to show correct maximum program times. Corrected error in Max block program time in section 6.7 Corrected typical erase time in section 6.7
2/15/01	-007	Updated cover page to reflect 100K minimum erase cycles. Updated cover page to reflect 110 ns 32M read speed. Removed Set Read Configuration command from Table 4. Updated Table 8 to reflect reserved bits are 1-7; not 2-7. Updated Table 16 bit 2 definition from R to PSS. Changed V <sub>PENLK</sub> Max voltage from 0.8 V to 2.0 V, Section 6.4, <i>DC Characteristics</i> Updated 32Mbit Read Parameters R1, R2 and R3 to reflect 110ns, Section 6.5, <i>AC Characteristics—Read-Only Operations</i> <sup>(1,2)</sup> Updated write parameter W13 (t <sub>WHRL</sub> ) from 90 ns to 500 ns, Section 6.6, <i>AC Characteristics—Write Operations</i> Updated Max. Program Suspend Latency W16 (t <sub>WHRH1</sub> ) from 30 to 75 μs, Section 6.7, <i>Block Erase, Program, and Lock-Bit Configuration Performance</i> <sup>(1,2,3)</sup>
04/13/01	-008	Revised Section 7.0, <i>Ordering Information</i>



## 1.0 Product Overview

---

The 0.25  $\mu$  3 Volt Intel StrataFlash memory family contains high-density memories organized as 16 Mbytes or 8 Mwords (128-Mbit), 8 Mbytes or 4 Mwords (64-Mbit), and 4 Mbytes or 2 Mwords (32-Mbit). These devices can be accessed as 8- or 16-bit words. The 128-Mbit device is organized as one-hundred-twenty-eight 128-Kbyte (131,072 bytes) erase blocks. The 64-Mbit device is organized as sixty-four 128-Kbyte erase blocks while the 32-Mbits device contains thirty-two 128-Kbyte erase blocks. Blocks are selectively and individually lockable and unlockable in-system. A 128-bit protection register has multiple uses, including unique flash device identification.

The device's optimized architecture and interface dramatically increases read performance by supporting page-mode reads. This read mode is ideal for non-clock memory systems.

A Common Flash Interface (CFI) permits software algorithms to be used for entire families of devices. This allows device-independent, JEDEC ID-independent, and forward- and backward-compatible software support for the specified flash device families. Flash vendors can standardize their existing interfaces for long-term compatibility.

Scalable Command Set (SCS) allows a single, simple software driver in all host systems to work with all SCS-compliant flash memory devices, independent of system-level packaging (e.g., memory card, SIMM, or direct-to-board placement). Additionally, SCS provides the highest system/device data transfer rates and minimizes device and system-level implementation costs.

A Command User Interface (CUI) serves as the interface between the system processor and internal operation of the device. A valid command sequence written to the CUI initiates device automation. An internal Write State Machine (WSM) automatically executes the algorithms and timings necessary for block erase, program, and lock-bit configuration operations.

A block erase operation erases one of the device's 128-Kbyte blocks typically within one second— independent of other blocks. Each block can be independently erased 100,000 times. Block erase suspend mode allows system software to suspend block erase to read or program data from any other block. Similarly, program suspend allows system software to suspend programming (byte/ word program and write-to-buffer operations) to read data or execute code from any other block that is not being suspended.

Each device incorporates a Write Buffer of 32 bytes (16 words) to allow optimum programming performance. By using the Write Buffer, data is programmed in buffer increments. This feature can improve system program performance more than 20 times over non-Write Buffer writes.

Individual block locking uses block lock-bits to lock and unlock blocks. Block lock-bits gate block erase and program operations. Lock-bit configuration operations set and clear lock-bits (Set Block Lock-Bit and Clear Block Lock-Bits commands).

The status register indicates when the WSM's block erase, program, or lock-bit configuration operation is finished.

The STS (STATUS) output gives an additional indicator of WSM activity by providing both a hardware signal of status (versus software polling) and status masking (interrupt masking for background block erase, for example). Status indication using STS minimizes both CPU overhead and system power consumption. When configured in level mode (default mode), it acts as a RY/ BY# pin. When low, STS indicates that the WSM is performing a block erase, program, or lock-bit configuration. STS-high indicates that the WSM is ready for a new command, block erase is

suspended (and programming is inactive), program is suspended, or the device is in reset/power-down mode. Additionally, the configuration command allows the STS pin to be configured to pulse on completion of programming and/or block erases.

Three CE pins are used to enable and disable the device. A unique CE logic design (see [Table 2, “Chip Enable Truth Table” on page 7](#)) reduces decoder logic typically required for multi-chip designs. External logic is not required when designing a single chip, a dual chip, or a 4-chip miniature card or SIMM module.

The BYTE# pin allows either x8 or x16 read/writes to the device. BYTE# at logic low selects 8-bit mode; address  $A_0$  selects between the low byte and high byte. BYTE# at logic high enables 16-bit operation; address  $A_1$  becomes the lowest order address and address  $A_0$  is not used (don't care). A device block diagram is shown in [Figure 1 on page 2](#).

When the device is disabled (see [Table 2 on page 7](#)) and the RP# pin is at  $V_{CC}$ , the standby mode is enabled. When the RP# pin is at GND, a further power-down mode is enabled which minimizes power consumption and provides write protection during reset. A reset time ( $t_{PHQV}$ ) is required from RP# switching high until outputs are valid. Likewise, the device has a wake time ( $t_{PHWL}$ ) from RP#-high until writes to the CUI are recognized. With RP# at GND, the WSM is reset and the status register is cleared.

3 Volt Intel StrataFlash memory devices are available in two package types. Both 56-lead TSOP (Thin Small Outline Package) and BGA (Ball Grid Array Package) support all offered densities. [Figure 2](#) and [Figure 3](#) show the pinouts.

**Figure 1. 3 Volt Intel® StrataFlash™ Memory Block Diagram**

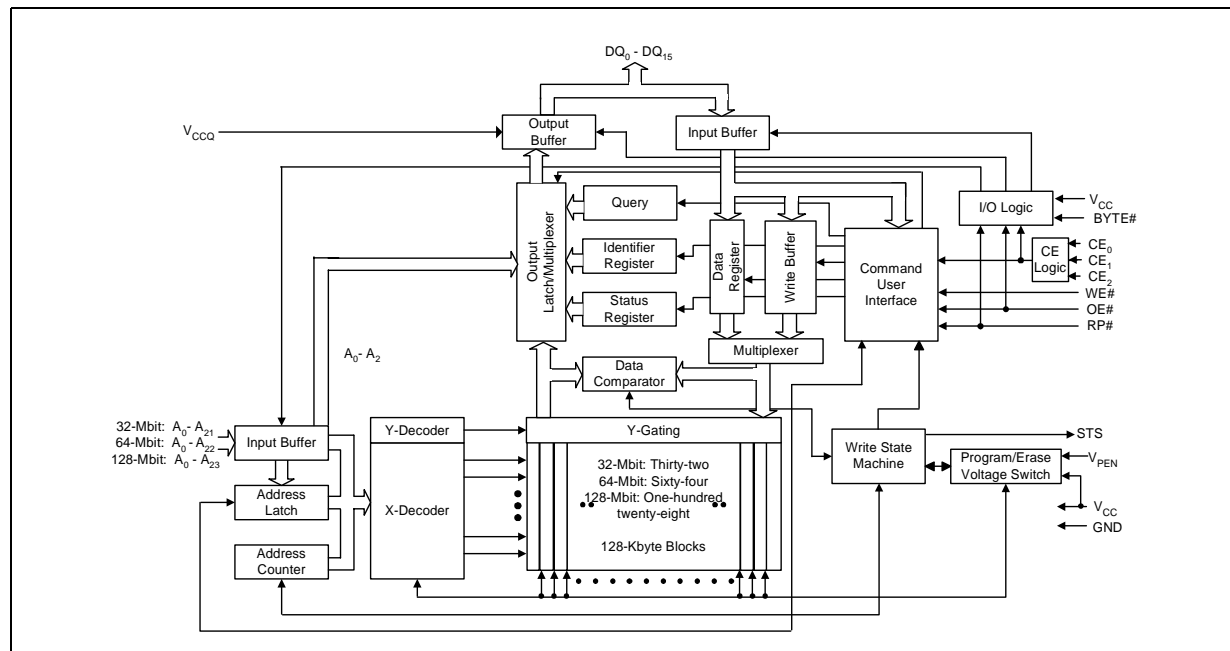
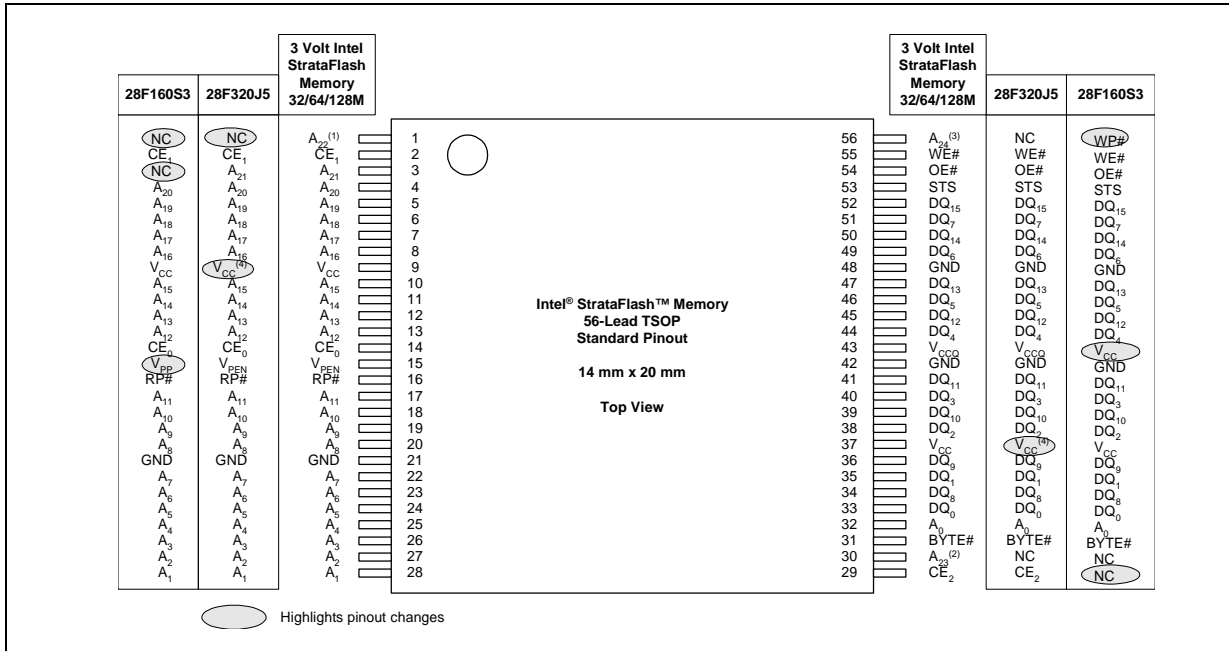

**Table 1. Lead Descriptions**

Symbol	Type	Name and Function
A <sub>0</sub>	INPUT	<b>BYTE-SELECT ADDRESS:</b> Selects between high and low byte when the device is in x8 mode. This address is latched during a x8 program cycle. Not used in x16 mode (i.e., the A <sub>0</sub> input buffer is turned off when BYTE# is high).
A <sub>1</sub> –A <sub>23</sub>	INPUT	<b>ADDRESS INPUTS:</b> Inputs for addresses during read and program operations. Addresses are internally latched during a program cycle. 32-Mbit: A <sub>0</sub> –A <sub>21</sub> 64-Mbit: A <sub>0</sub> –A <sub>22</sub> 128-Mbit: A <sub>0</sub> –A <sub>23</sub>
DQ <sub>0</sub> –DQ <sub>7</sub>	INPUT/ OUTPUT	<b>LOW-BYTE DATA BUS:</b> Inputs data during buffer writes and programming, and inputs commands during Command User Interface (CUI) writes. Outputs array, query, identifier, or status data in the appropriate read mode. Floated when the chip is de-selected or the outputs are disabled. Outputs DQ <sub>6</sub> –DQ <sub>0</sub> are also floated when the Write State Machine (WSM) is busy. Check SR.7 (status register bit 7) to determine WSM status.
DQ <sub>8</sub> – DQ <sub>15</sub>	INPUT/ OUTPUT	<b>HIGH-BYTE DATA BUS:</b> Inputs data during x16 buffer writes and programming operations. Outputs array, query, or identifier data in the appropriate read mode; not used for status register reads. Floated when the chip is de-selected, the outputs are disabled, or the WSM is busy.
CE <sub>0</sub> , CE <sub>1</sub> , CE <sub>2</sub>	INPUT	<b>CHIP ENABLES:</b> Activates the device's control logic, input buffers, decoders, and sense amplifiers. When the device is de-selected (see <a href="#">Table 2 on page 7</a> ), power reduces to standby levels. All timing specifications are the same for these three signals. Device selection occurs with the first edge of CE <sub>0</sub> , CE <sub>1</sub> , or CE <sub>2</sub> that enables the device. Device deselection occurs with the first edge of CE <sub>0</sub> , CE <sub>1</sub> , or CE <sub>2</sub> that disables the device (see <a href="#">Table 2 on page 7</a> ).
RP#	INPUT	<b>RESET/ POWER-DOWN:</b> Resets internal automation and puts the device in power-down mode. RP#-high enables normal operation. Exit from reset sets the device to read array mode. When driven low, RP# inhibits write operations which provides data protection during power transitions.
OE#	INPUT	<b>OUTPUT ENABLE:</b> Activates the device's outputs through the data buffers during a read cycle. OE# is active low.
WE#	INPUT	<b>WRITE ENABLE:</b> Controls writes to the Command User Interface, the Write Buffer, and array blocks. WE# is active low. Addresses and data are latched on the rising edge of the WE# pulse.
STS	OPEN DRAIN OUTPUT	<b>STATUS:</b> Indicates the status of the internal state machine. When configured in level mode (default mode), it acts as a RY/BY# pin. When configured in one of its pulse modes, it can pulse to indicate program and/or erase completion. For alternate configurations of the STATUS pin, see the Configurations command. Tie STS to V <sub>CCQ</sub> with a pull-up resistor.
BYTE#	INPUT	<b>BYTE ENABLE:</b> BYTE# low places the device in x8 mode. All data is then input or output on DQ <sub>0</sub> –DQ <sub>7</sub> , while DQ <sub>8</sub> –DQ <sub>15</sub> float. Address A <sub>0</sub> selects between the high and low byte. BYTE# high places the device in x16 mode, and turns off the A <sub>0</sub> input buffer. Address A <sub>1</sub> then becomes the lowest order address.
V <sub>PEN</sub>	INPUT	<b>ERASE / PROGRAM / BLOCK LOCK ENABLE:</b> For erasing array blocks, programming data, or configuring lock-bits. With V <sub>PEN</sub> ≤ V <sub>PENLK</sub> , memory contents cannot be altered.
V <sub>CC</sub>	SUPPLY	<b>DEVICE POWER SUPPLY:</b> With V <sub>CC</sub> ≤ V <sub>LKO</sub> , all write attempts to the flash memory are inhibited.
V <sub>CCQ</sub>	OUTPUT BUFFER SUPPLY	<b>OUTPUT BUFFER POWER SUPPLY:</b> This voltage controls the device's output voltages. To obtain output voltages compatible with system data bus voltages, connect V <sub>CCQ</sub> to the system supply voltage.
GND	SUPPLY	<b>GROUND:</b> Do not float any ground pins.
NC		<b>NO CONNECT:</b> Lead is not internally connected; it may be driven or floated.
DU		<b>DON'T USE: Do not drive ball to V<sub>IH</sub> or V<sub>IL</sub>, leave disconnected</b>



**Figure 3. 3 Volt Intel® StrataFlash™ Memory 56-Lead TSOP (32/64/128 Mbit) Offers an Easy Migration from the 32-Mbit Intel StrataFlash Component (28F320J5) or the 16-Mbit FlashFile™ Component (28F160S3)**



0667-03

- NOTES:**
1. A<sub>22</sub> exists on 64-, 128- and 256-Mbit densities. On 32-Mbit densities this pin is a no-connect (NC).
  2. A<sub>23</sub> exists on 128-Mbit densities. On 32- and 64-Mbit densities this pin is a no-connect (NC).
  3. A<sub>24</sub> exists on 256-Mbit densities. On 32-, 64- and 128-Mbit densities this pin is a no-connect (NC).
  4. V<sub>CC</sub> = 5 V ± 10% for the 28F640J5/28F320J5.

## 2.0 Principles of Operation

---

The Intel StrataFlash memory devices include an on-chip WSM to manage block erase, program, and lock-bit configuration functions. It allows for 100% TTL-level control inputs, fixed power supplies during block erasure, program, lock-bit configuration, and minimal processor overhead with RAM-like interface timings.

After initial device power-up or return from reset/power-down mode (see [Section 3.0, “Bus Operations” on page 7](#)), the device defaults to read array mode. Manipulation of external memory control pins allows array read, standby, and output disable operations.

Read array, status register, query, and identifier codes can be accessed through the CUI (Command User Interface) independent of the  $V_{PEN}$  voltage.  $V_{PENH}$  on  $V_{PEN}$  enables successful block erasure, programming, and lock-bit configuration. All functions associated with altering memory contents—block erase, program, lock-bit configuration—are accessed via the CUI and verified through the status register.

Commands are written using standard micro-processor write timings. The CUI contents serve as input to the WSM, which controls the block erase, program, and lock-bit configuration. The internal algorithms are regulated by the WSM, including pulse repetition, internal verification, and margining of data. Addresses and data are internally latched during program cycles.

Interface software that initiates and polls progress of block erase, program, and lock-bit configuration can be stored in any block. This code is copied to and executed from system RAM during flash memory updates. After successful completion, reads are again possible via the Read Array command. Block erase suspend allows system software to suspend a block erase to read or program data from/to any other block. Program suspend allows system software to suspend a program to read data from any other flash memory array location.

## 2.1 Data Protection

Depending on the application, the system designer may choose to make the  $V_{PEN}$  switchable (available only when memory block erases, programs, or lock-bit configurations are required) or hardwired to  $V_{PENH}$ . The device accommodates either design practice and encourages optimization of the processor-memory interface.

When  $V_{PEN} \leq V_{PENLK}$ , memory contents cannot be altered. The CUI's two-step block erase, byte/word program, and lock-bit configuration command sequences provide protection from unwanted operations even when  $V_{PENH}$  is applied to  $V_{PEN}$ . All program functions are disabled when  $V_{CC}$  is below the write lockout voltage  $V_{LKO}$  or when  $RP\#$  is  $V_{IL}$ . The device's block locking capability provides additional protection from inadvertent code or data alteration by gating erase and program operations.

### 3.0 Bus Operations

The local CPU reads and writes flash memory in-system. All bus cycles to or from the flash memory conform to standard microprocessor bus cycles.

Figure 4. Memory Map

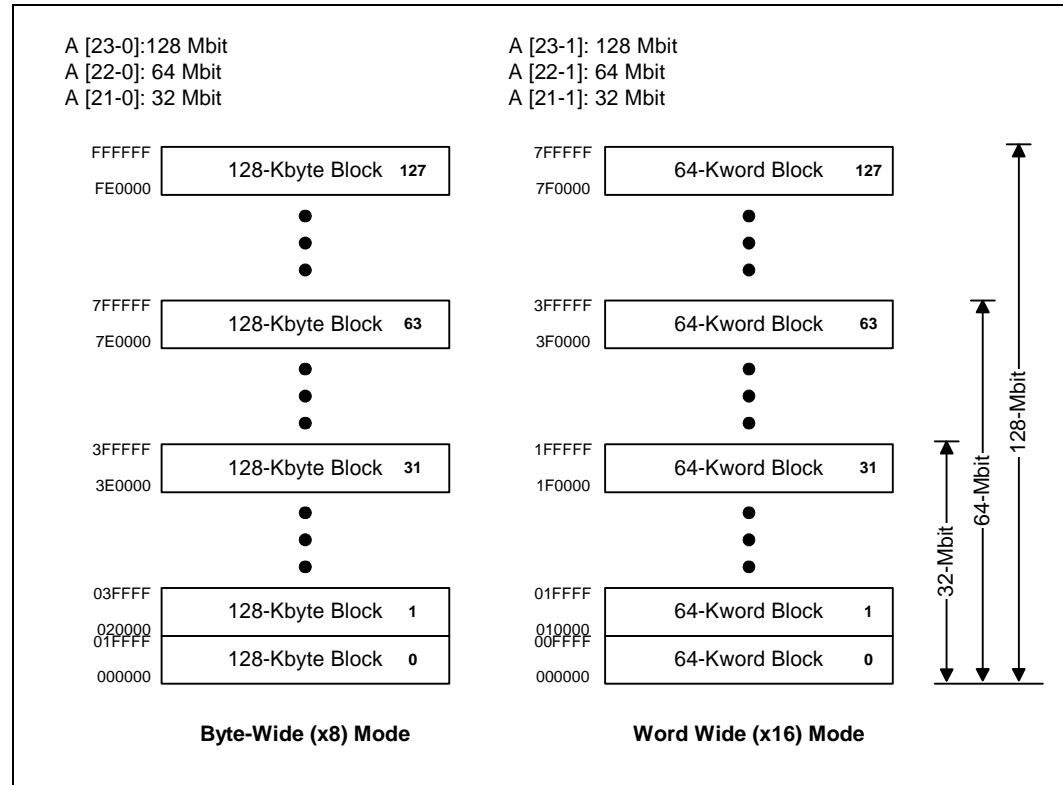

Table 2. Chip Enable Truth Table

CE <sub>2</sub>	CE <sub>1</sub>	CE <sub>0</sub>	DEVICE
V <sub>IL</sub>	V <sub>IL</sub>	V <sub>IL</sub>	Enabled
V <sub>IL</sub>	V <sub>IL</sub>	V <sub>IH</sub>	Disabled
V <sub>IL</sub>	V <sub>IH</sub>	V <sub>IL</sub>	Disabled
V <sub>IL</sub>	V <sub>IH</sub>	V <sub>IH</sub>	Disabled
V <sub>IH</sub>	V <sub>IL</sub>	V <sub>IL</sub>	Enabled
V <sub>IH</sub>	V <sub>IL</sub>	V <sub>IH</sub>	Enabled
V <sub>IH</sub>	V <sub>IH</sub>	V <sub>IL</sub>	Enabled
V <sub>IH</sub>	V <sub>IH</sub>	V <sub>IH</sub>	Disabled

NOTE: For single-chip applications, CE<sub>2</sub> and CE<sub>1</sub> can be strapped to GND.

### 3.1 Read

Information can be read from any block, query, identifier codes, or status register independent of the  $V_{PEN}$  voltage.

Upon initial device power-up or after exit from reset/power-down mode, the device automatically resets to read array mode. Otherwise, write the appropriate read mode command (Read Array, Read Query, Read Identifier Codes, or Read Status Register) to the CUI. Six control pins dictate the data flow in and out of the component:  $CE_0$ ,  $CE_1$ ,  $CE_2$ ,  $OE\#$ ,  $WE\#$ , and  $RP\#$ . The device must be enabled (see Table 2, “Chip Enable Truth Table” on page 7), and  $OE\#$  must be driven active to obtain data at the outputs.  $CE_0$ ,  $CE_1$ , and  $CE_2$  are the device selection controls and, when enabled (see Table 2), select the memory device.  $OE\#$  is the data output ( $DQ_0$ – $DQ_{15}$ ) control and, when active, drives the selected memory data onto the I/O bus.  $WE\#$  must be at  $V_{IH}$ .

When reading information in read array mode, the device defaults to asynchronous page mode. This mode provides high data transfer rate for memory subsystems. In this state, data is internally read and stored in a high-speed page buffer.  $A_{2:0}$  addresses data in the page buffer. The page size is four words or eight bytes. Asynchronous word/byte mode is supported with no additional commands required.

### 3.2 Output Disable

With  $OE\#$  at a logic-high level ( $V_{IH}$ ), the device outputs are disabled. Output pins  $DQ_0$ – $DQ_{15}$  are placed in a high-impedance state.

### 3.3 Standby

$CE_0$ ,  $CE_1$ , and  $CE_2$  can disable the device (see Table 2) and place it in standby mode which substantially reduces device power consumption.  $DQ_0$ – $DQ_{15}$  outputs are placed in a high-impedance state independent of  $OE\#$ . If deselected during block erase, program, or lock-bit configuration, the WSM continues functioning, and consuming active power until the operation completes.

### 3.4 Reset/Power-Down

$RP\#$  at  $V_{IL}$  initiates the reset/power-down mode.

In read modes,  $RP\#$ -low deselects the memory, places output drivers in a high-impedance state, and turns off numerous internal circuits.  $RP\#$  must be held low for a minimum of  $t_{PLPH}$ . Time  $t_{PHQV}$  is required after return from reset mode until initial memory access outputs are valid. After this wake-up interval, normal operation is restored. The CUI is reset to read array mode and status register is set to 80H.

During block erase, program, or lock-bit configuration modes,  $RP\#$ -low will abort the operation. In default mode,  $STS$  transitions low and remains low for a maximum time of  $t_{PLPH} + t_{PHRH}$  until the reset operation is complete. Memory contents being altered are no longer valid; the data may be partially corrupted after a program or partially altered after an erase or lock-bit configuration. Time  $t_{PHWL}$  is required after  $RP\#$  goes to logic-high ( $V_{IH}$ ) before another command can be written.

As with any automated device, it is important to assert RP# during system reset. When the system comes out of reset, it expects to read from the flash memory. Automated flash memories provide status information when accessed during block erase, program, or lock-bit configuration modes. If a CPU reset occurs with no flash memory reset, proper initialization may not occur because the flash memory may be providing status information instead of array data. Intel<sup>®</sup> Flash memories allow proper initialization following a system reset through the use of the RP# input. In this application, RP# is controlled by the same RESET# signal that resets the system CPU.

### 3.5 Read Query

The read query operation outputs block status information, CFI (Common Flash Interface) ID string, system interface information, device geometry information, and Intel-specific extended query information.

### 3.6 Read Identifier Codes

The read identifier codes operation outputs the manufacturer code, device code and the block lock configuration codes for each block (see [Figure 5 on page 10](#)). Using the manufacturer and device codes, the system CPU can automatically match the device with its proper algorithms. The block lock configuration codes identify locked and unlocked blocks.

### 3.7 Write

Writing commands to the CUI enables reading of device data, query, identifier codes, inspection and clearing of the status register, and, when  $V_{PEN} = V_{PENH}$ , block erasure, program, and lock-bit configuration.

The Block Erase command requires appropriate command data and an address within the block to be erased. The Byte/Word Program command requires the command and address of the location to be written. Set Block Lock-Bit commands require the command and block within the device to be locked. The Clear Block Lock-Bits command requires the command and address within the device.

The CUI does not occupy an addressable memory location. It is written when the device is enabled and WE# is active. The address and data needed to execute a command are latched on the rising edge of WE# or the first edge of CE<sub>0</sub>, CE<sub>1</sub>, or CE<sub>2</sub> that disables the device (see [Table 2](#)). Standard microprocessor write timings are used.

## 4.0 Command Definitions

---

When the  $V_{PEN}$  voltage  $\leq V_{PENLK}$ , only read operations from the status register, query, identifier codes, or blocks are enabled. Placing  $V_{PENH}$  on  $V_{PEN}$  additionally enables block erase, program, and lock-bit configuration operations.

Device operations are selected by writing specific commands into the CUI. [Table 4](#) defines these commands.

Figure 5. Device Identifier Code Memory Map

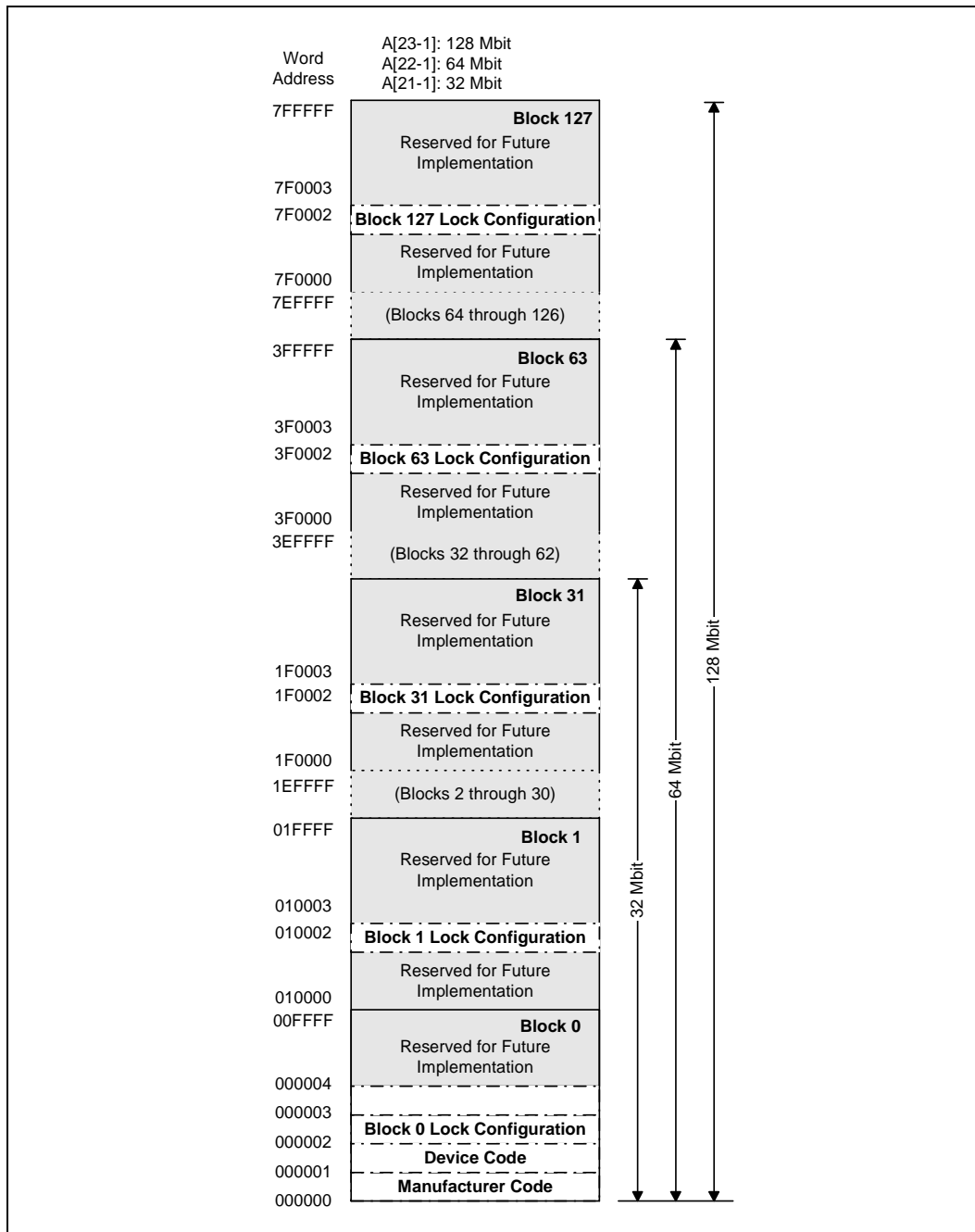

0606-06a

**NOTE:**  $A_0$  is not used in either x8 or x16 modes when obtaining these identifier codes. Data is always given on the low byte in x16 mode (upper byte contains 00h).

**Table 3. Bus Operations**

Mode	Notes	RP#	CE <sub>0,1,2</sub> <sup>(1)</sup>	OE# <sup>(2)</sup>	WE# <sup>(2)</sup>	Address	V <sub>PEN</sub>	DQ <sup>(3)</sup>	STS (default mode)
Read Array	4,5,6	V <sub>IH</sub>	Enabled	V <sub>IL</sub>	V <sub>IH</sub>	X	X	D <sub>OUT</sub>	High Z <sup>(7)</sup>
Output Disable		V <sub>IH</sub>	Enabled	V <sub>IH</sub>	V <sub>IH</sub>	X	X	High Z	X
Standby		V <sub>IH</sub>	Disabled	X	X	X	X	High Z	X
Reset/Power-Down Mode		V <sub>IL</sub>	X	X	X	X	X	High Z	High Z <sup>(7)</sup>
Read Identifier Codes		V <sub>IH</sub>	Enabled	V <sub>IL</sub>	V <sub>IH</sub>	See Figure 5	X	Note 8	High Z <sup>(7)</sup>
Read Query		V <sub>IH</sub>	Enabled	V <sub>IL</sub>	V <sub>IH</sub>	See Table 7	X	Note 9	High Z <sup>(7)</sup>
Read Status (WSM off)		V <sub>IH</sub>	Enabled	V <sub>IL</sub>	V <sub>IH</sub>	X	X	D <sub>OUT</sub>	
Read Status (WSM on)		V <sub>IH</sub>	Enabled	V <sub>IL</sub>	V <sub>IH</sub>	X	X	DQ <sub>7</sub> = D <sub>OUT</sub> DQ <sub>15-8</sub> = High Z DQ <sub>6-0</sub> = High Z	
Write	6,10,11	V <sub>IH</sub>	Enabled	V <sub>IH</sub>	V <sub>IL</sub>	X	V <sub>PENH</sub>	D <sub>IN</sub>	X

**NOTES:**

- See Table 2 for valid CE configurations.
- OE# and WE# should never be enabled simultaneously.
- DQ refers to DQ<sub>0</sub>-DQ<sub>7</sub> if BYTE# is low and DQ<sub>0</sub>-DQ<sub>15</sub> if BYTE# is high.
- Refer to *DC Characteristics*. When V<sub>PEN</sub> ≤ V<sub>PENLK</sub>, memory contents can be read, but not altered.
- X can be V<sub>IL</sub> or V<sub>IH</sub> for control and address pins, and V<sub>PENLK</sub> or V<sub>PENH</sub> for V<sub>PEN</sub>. See *DC Characteristics* for V<sub>PENLK</sub> and V<sub>PENH</sub> voltages.
- In default mode, STS is V<sub>OL</sub> when the WSM is executing internal block erase, program, or lock-bit configuration algorithms. It is V<sub>OH</sub> when the WSM is not busy, in block erase suspend mode (with programming inactive), program suspend mode, or reset/power-down mode.
- High Z will be V<sub>OH</sub> with an external pull-up resistor.
- See Section 3.6 for read identifier code data.
- See Section 4.2 for read query data.
- Command writes involving block erase, program, or lock-bit configuration are reliably executed when V<sub>PEN</sub> = V<sub>PENH</sub> and V<sub>CC</sub> is within specification.
- Refer to Table 4 for valid D<sub>IN</sub> during a write operation.

Table 4. Intel® StrataFlash™ Memory Command Set Definitions<sup>(1)</sup>

Command	Scalable or Basic Command Set <sup>(2)</sup>	Bus Cycles Req'd.	Notes	First Bus Cycle			Second Bus Cycle		
				Oper <sup>(3)</sup>	Addr <sup>(4)</sup>	Data <sup>(5,6)</sup>	Oper <sup>(3)</sup>	Addr <sup>(4)</sup>	Data <sup>(5,6)</sup>
Read Array	SCS/BCS	1		Write	X	FFH			
Read Identifier Codes	SCS/BCS	≥ 2	7	Write	X	90H	Read	IA	ID
Read Query	SCS	≥ 2		Write	X	98H	Read	QA	QD
Read Status Register	SCS/BCS	2	8	Write	X	70H	Read	X	SRD
Clear Status Register	SCS/BCS	1		Write	X	50H			
Write to Buffer	SCS/BCS	> 2	9, 10, 11	Write	BA	E8H	Write	BA	N
Word/Byte Program	SCS/BCS	2	12,13	Write	X	40H or 10H	Write	PA	PD
Block Erase	SCS/BCS	2	11,12	Write	BA	20H	Write	BA	D0H
Block Erase, Program Suspend	SCS/BCS	1	12,14	Write	X	B0H			
Block Erase, Program Resume	SCS/BCS	1	12	Write	X	D0H			
Configuration	SCS	2		Write	X	B8H	Write	X	CC
Set Block Lock-Bit	SCS	2		Write	X	60H	Write	BA	01H
Clear Block Lock-Bits	SCS	2	15	Write	X	60H	Write	X	D0H
Protection Program		2		Write	X	C0H	Write	PA	PD

**NOTES:**

- Commands other than those shown above are reserved by Intel for future device implementations and should not be used.
- The Basic Command Set (BCS) is the same as the 28F008SA Command Set or Intel Standard Command Set. The Scalable Command Set (SCS) is also referred to as the Intel Extended Command Set.
- Bus operations are defined in [Table 3](#).
- X = Any valid address within the device.  
BA = Address within the block.  
IA = Identifier Code Address: see [Figure 5](#) and [Table 15](#).  
QA = Query database Address.  
PA = Address of memory location to be programmed.  
RCD = Data to be written to the read configuration register. This data is presented to the device on A<sub>16-1</sub>; all other address inputs are ignored.
- ID = Data read from Identifier Codes.  
QD = Data read from Query database.  
SRD = Data read from status register. See [Table 16](#) for a description of the status register bits.  
PD = Data to be programmed at location PA. Data is latched on the rising edge of WE#.  
CC = Configuration Code.
- The upper byte of the data bus (DQ<sub>8</sub>-DQ<sub>15</sub>) during command writes is a "Don't Care" in x16 operation.
- Following the Read Identifier Codes command, read operations access manufacturer, device and block lock codes. See [Section 4.3](#) for read identifier code data.
- If the WSM is running, only DQ<sub>7</sub> is valid; DQ<sub>15</sub>-DQ<sub>8</sub> and DQ<sub>6</sub>-DQ<sub>0</sub> float, which places them in a high-impedance state.
- After the Write to Buffer command is issued check the XSR to make sure a buffer is available for writing.

10. The number of bytes/words to be written to the Write Buffer =  $N + 1$ , where  $N$  = byte/word count argument. Count ranges on this device for byte mode are  $N = 00H$  to  $N = 1FH$  and for word mode are  $N = 0000H$  to  $N = 000FH$ . The third and consecutive bus cycles, as determined by  $N$ , are for writing data into the Write Buffer. The Confirm command (D0H) is expected after exactly  $N + 1$  write cycles; any other command at that point in the sequence aborts the write to buffer operation. Please see [Figure 7, "Write to Buffer Flowchart"](#) on [page 30](#) for additional information.
11. The write to buffer or erase operation does not begin until a Confirm command (D0h) is issued.
12. Attempts to issue a block erase or program to a locked block.
13. Either 40H or 10H are recognized by the WSM as the byte/word program setup.
14. Program suspends can be issued after either the Write-to-Buffer or Word-/Byte-Program operation is initiated.
15. The clear block lock-bits operation simultaneously clears all block lock-bits.

## 4.1 Read Array Command

Upon initial device power-up and after exit from reset/power-down mode, the device defaults to read array mode. The read configuration register defaults to asynchronous read page mode. The Read Array command also causes the device to enter read array mode. The device remains enabled for reads until another command is written. Once the internal WSM has started a block erase, program, or lock-bit configuration, the device will not recognize the Read Array command until the WSM completes its operation unless the WSM is suspended via an Erase or Program Suspend command. The Read Array command functions independently of the  $V_{PEN}$  voltage.

## 4.2 Read Query Mode Command

This section defines the data structure or "database" returned by the Common Flash Interface (CFI) Query command. System software should parse this structure to gain critical information such as block size, density, x8/x16, and electrical specifications. Once this information has been obtained, the software will know which command sets to use to enable flash writes, block erases, and otherwise control the flash component. The Query is part of an overall specification for multiple command set and control interface descriptions called Common Flash Interface, or CFI.

### 4.2.1 Query Structure Output

The Query "database" allows system software to gain information for controlling the flash component. This section describes the device's CFI-compliant interface that allows the host system to access Query data.

Query data are always presented on the lowest-order data outputs ( $DQ_{0-7}$ ) only. The numerical offset value is the address relative to the maximum bus width supported by the device. On this family of devices, the Query table device starting address is a 10h, which is a word address for x16 devices.

For a word-wide (x16) device, the first two bytes of the Query structure, "Q" and "R" in ASCII, appear on the low byte at word addresses 10h and 11h. This CFI-compliant device outputs 00H data on upper bytes. Thus, the device outputs ASCII "Q" in the low byte ( $DQ_{0-7}$ ) and 00h in the high byte ( $DQ_{8-15}$ ).

At Query addresses containing two or more bytes of information, the least significant data byte is presented at the lower address, and the most significant data byte is presented at the higher address.

In all of the following tables, addresses and data are represented in hexadecimal notation, so the “h” suffix has been dropped. In addition, since the upper byte of word-wide devices is always “00h,” the leading “00” has been dropped from the table notation and only the lower byte value is shown. Any x16 device outputs can be assumed to have 00h on the upper byte in this mode.

**Table 5. Summary of Query Structure Output as a Function of Device and Mode**

Device Type/ Mode	Query start location in maximum device bus width addresses	Query data with maximum device bus width addressing			Query data with byte addressing		
		Hex Offset	Hex Code	ASCII Value	Hex Offset	Hex Code	ASCII Value
x16 device x16 mode	10h	10:	0051	“Q”	20:	51	“Q”
		11:	0052	“R”	21:	00	“Null”
		12:	0059	“Y”	22:	52	“R”
x16 device x8 mode	N/A <sup>(1)</sup>	N/A <sup>(1)</sup>			20:	51	“Q”
					21:	51	“Q”
					22:	52	“R”

**NOTE:**

1. The system must drive the lowest order addresses to access all the device’s array data when the device is configured in x8 mode. Therefore, word addressing, where these lower addresses are not toggled by the system, is “Not Applicable” for x8-configured devices.

**Table 6. Example of Query Structure Output of a x16- and x8-Capable Device**

Word Addressing			Byte Addressing		
Offset	Hex Code	Value	Offset	Hex Code	Value
A <sub>15</sub> –A <sub>0</sub>	D <sub>15</sub> –D <sub>0</sub>		A <sub>7</sub> –A <sub>0</sub>	D <sub>7</sub> –D <sub>0</sub>	
0010h	0051	“Q”	20h	51	“Q”
0011h	0052	“R”	21h	51	“Q”
0012h	0059	“Y”	22h	52	“R”
0013h	P_ID <sub>LO</sub>	PrVendor	23h	52	“R”
0014h	P_ID <sub>HI</sub>	ID #	24h	59	“Y”
0015h	P <sub>LO</sub>	PrVendor	25h	59	“Y”
0016h	P <sub>HI</sub>	TblAdr	26h	P_ID <sub>LO</sub>	PrVendor
0017h	A_ID <sub>LO</sub>	AltVendor	27h	P_ID <sub>LO</sub>	ID #
0018h	A_ID <sub>HI</sub>	ID #	28h	P_ID <sub>HI</sub>	ID #
...	...	...	...	...	...

## 4.2.2 Query Structure Overview

The Query command causes the flash component to display the Common Flash Interface (CFI) Query structure or “database.” The structure sub-sections and address locations are summarized below. See *AP-646 Common Flash Interface (CFI) and Command Sets* (order number 292204) for a full description of CFI.

The following sections describe the Query structure sub-sections in detail.

**Table 7. Query Structure<sup>(1)</sup>**

Offset	Sub-Section Name	Description
00h		Manufacturer Code
01h		Device Code
(BA+2)h <sup>(2)</sup>	Block Status Register	Block-Specific Information
04-0Fh	Reserved	<i>Reserved for Vendor-Specific Information</i>
10h	CFI Query Identification String	<i>Reserved for Vendor-Specific Information</i>
1Bh	System Interface Information	Command Set ID and Vendor Data Offset
27h	Device Geometry Definition	Flash Device Layout
P <sup>(3)</sup>	Primary Intel-Specific Extended Query Table	Vendor-Defined Additional Information Specific to the Primary Vendor Algorithm

**NOTES:**

1. Refer to the Query Structure Output section and offset 28h for the detailed definition of offset address as a function of device bus width and mode.
2. BA = Block Address beginning location (i.e., 02000h is block 2's beginning location when the block size is 128 Kbyte).
3. Offset 15 defines "P" which points to the *Primary Intel-Specific Extended Query Table*.

### 4.2.3 Block Status Register

The block status register indicates whether an erase operation completed successfully or whether a given block is locked or can be accessed for flash program/erase operations.

**Table 8. Block Status Register**

Offset	Length	Description	Address	Value
(BA+2)h <sup>(1)</sup>	1	Block Lock Status Register	BA+2:	--00 or --01
		BSR.0 Block Lock Status 0 = Unlocked 1 = Locked	BA+2:	(bit 0): 0 or 1
		BSR 1–7: <i>Reserved for Future Use</i>	BA+2:	(bit 1–7): 0

**NOTE:**

1. BA = The beginning location of a Block Address (i.e., 008000h is block 1's (64-KB block) beginning location in word mode).

### 4.2.4 CFI Query Identification String

The CFI Query Identification String provides verification that the component supports the Common Flash Interface specification. It also indicates the specification version and supported vendor-specified command set(s).

**Table 9. CFI Identification**

Offset	Length	Description	Add.	Hex Code	Value
10h	3	Query-unique ASCII string "QRY"	10	--51	"Q"
			11:	--52	"R"
			12:	--59	"Y"
13h	2	Primary vendor command set and control interface ID code. 16-bit ID code for vendor-specified algorithms	13:	--01	
			14:	--00	
15h	2	Extended Query Table primary algorithm address	15:	--31	
			16:	--00	

Table 9. CFI Identification

Offset	Length	Description	Add.	Hex Code	Value
17h	2	Alternate vendor command set and control interface ID code. 0000h means no second vendor-specified algorithm exists	17: 18:	--00 --00	
19h	2	Secondary algorithm Extended Query Table address. 0000h means none exists	19: 1A:	--00 --00	

## 4.2.5 System Interface Information

The following device information can optimize system interface software.

Table 10. System Interface Information

Offset	Length	Description	Add.	Hex Code	Value
1Bh	1	V <sub>CC</sub> logic supply minimum program/erase voltage bits 0–3 BCD 100 mV bits 4–7 BCD volts	1B:	--27	2.7 V
1Ch	1	V <sub>CC</sub> logic supply maximum program/erase voltage bits 0–3 BCD 100 mV bits 4–7 BCD volts	1C:	--36	3.6 V
1Dh	1	V <sub>PP</sub> [programming] supply minimum program/erase voltage bits 0–3 BCD 100 mV bits 4–7 HEX volts	1D:	--00	0.0 V
1Eh	1	V <sub>PP</sub> [programming] supply maximum program/erase voltage bits 0–3 BCD 100 mV bits 4–7 HEX volts	1E:	--00	0.0 V
1Fh	1	"n" such that typical single word program time-out = 2 <sup>n</sup> μs	1F:	--07	128 μs
20h	1	"n" such that typical max. buffer write time-out = 2 <sup>n</sup> μs	20:	--07	128 μs
21h	1	"n" such that typical block erase time-out = 2 <sup>n</sup> ms	21:	--0A	1 s
22h	1	"n" such that typical full chip erase time-out = 2 <sup>n</sup> ms	22:	--00	NA
23h	1	"n" such that maximum word program time-out = 2 <sup>n</sup> times typical	23:	--04	2 ms
24h	1	"n" such that maximum buffer write time-out = 2 <sup>n</sup> times typical	24:	--04	2 ms
25h	1	"n" such that maximum block erase time-out = 2 <sup>n</sup> times typical	25:	--04	16 s
26h	1	"n" such that maximum chip erase time-out = 2 <sup>n</sup> times typical	26:	--00	NA

### 4.2.6 Device Geometry Definition

This field provides critical details of the flash device geometry.

**Table 11. Device Geometry Definition**

Offset	Length	Description	Code See Table Below		
27h	1	"n" such that device size = 2 <sup>n</sup> in number of bytes	27:		
28h	2	Flash device interface: <u>x8 async</u> <u>x16 async</u> <u>x8/x16 async</u> 28:00,29:00 28:01,29:00 28:02,29:00	28:	--02	x8/ x16
2Ah	2	"n" such that maximum number of bytes in write buffer = 2 <sup>n</sup>	29:	--00	
			2A:	--05	32
			2B:	--00	
2Ch	1	Number of erase block regions within device: 1. x = 0 means no erase blocking; the device erases in "bulk" 2. x specifies the number of device or partition regions with one or more contiguous same-size erase blocks 3. Symmetrically blocked partitions have one blocking region 4. Partition size = (total blocks) x (individual block size)	2C:	--01	1
2Dh	4	Erase Block Region 1 Information bits 0–15 = y, y+1 = number of identical-size erase blocks bits 16–31 = z, region erase block(s) size are z x 256 bytes	2D:		
			2E:		
			2F:		
			30:		

#### Device Geometry Definition

Address	32 Mbit	64 Mbit	128 Mbit
27:	--16	--17	--18
28:	--02	--02	--02
29:	--00	--00	--00
2A:	--05	--05	--05
2B:	--00	--00	--00
2C:	--01	--01	--01
2D:	--1F	--3F	--7F
2E:	--00	--00	--00
2F:	--00	--00	--00
30:	--02	--02	--02

## 4.2.7 Primary-Vendor Specific Extended Query Table

Certain flash features and commands are optional. The *Primary Vendor-Specific Extended Query* table specifies this and other similar information.

**Table 12. Primary Vendor-Specific Extended Query**

Offset <sup>(1)</sup> P = 31h	Length	Description (Optional Flash Features and Commands)	Add.	Hex Code	Value
(P+0)h (P+1)h (P+2)h	3	Primary extended query table Unique ASCII string "PRI"	31: 32: 33:	--50 --52 --49	"P" "R" "I"
(P+3)h	1	Major version number, ASCII	34:	--31	"1"
(P+4)h	1	Minor version number, ASCII	35:	--31	"1"
(P+5)h (P+6)h (P+7)h (P+8)h	4	Optional feature and command support (1=yes, 0=no) <i>bits 9–31 are reserved; undefined bits are "0." If bit 31 is "1" then another 31 bit field of optional features follows at the end of the bit-30 field.</i>	36: 37: 38: 39:	--0A --00 --00 --00	
		bit 0 Chip erase supported bit 1 Suspend erase supported bit 2 Suspend program supported bit 3 Legacy lock/unlock supported bit 4 Queued erase supported bit 5 Instant Individual block locking supported bit 6 Protection bits supported bit 7 Page-mode read supported bit 8 Synchronous read supported	bit 0 = 0 bit 1 = 1 bit 2 = 1 bit 3 = 1 <sup>(1)</sup> bit 4 = 0 bit 5 = 0 bit 6 = 1 bit 7 = 1 bit 8 = 0	No Yes Yes Yes <sup>(1)</sup> No No Yes Yes No	
(P+9)h	1	Supported functions after suspend: read Array, Status, Query Other supported operations are: <i>bits 1–7 reserved; undefined bits are "0"</i>	3A:	--01	
		bit 0 Program supported after erase suspend	bit 0 = 1		Yes
(P+A)h (P+B)h	2	Block status register mask <i>bits 2–15 are Reserved; undefined bits are "0"</i>	3B: 3C:	--01 --00	
		bit 0 Block Lock-Bit Status register active bit 1 Block Lock-Down Bit Status active	bit 0 = 1 bit 1 = 0		Yes No
(P+C)h	1	V <sub>CC</sub> logic supply highest performance program/erase voltage bits 0–3 BCD value in 100 mV bits 4–7 BCD value in volts	3D:	--33	3.3 V
(P+D)h	1	V <sub>PP</sub> optimum program/erase supply voltage bits 0–3 BCD value in 100 mV bits 4–7 HEX value in volts	3E:	--00	0.0 V

**NOTE:**

- Future devices may not support the described "Legacy Lock/Unlock" function. Thus bit 3 would have a value of "0."

**Table 13. Protection Register Information**

Offset <sup>(1)</sup> P = 31h	Length	Description (Optional Flash Features and Commands)	Add.	Hex Code	Value
(P+E)h	1	Number of Protection register fields in JEDEC ID space. "00h," indicates that 256 protection bytes are available	3F:	--01	01
(P+F)h (P+10)h (P+11)h (P+12)h	4	Protection Field 1: Protection Description This field describes user-available One Time Programmable (OTP) protection register bytes. Some are pre-programmed with device-unique serial numbers. Others are user-programmable. Bits 0-15 point to the protection register lock byte, the section's first byte. The following bytes are factory pre-programmed and user-programmable.  bits 0-7 = Lock/bytes JEDEC-plane physical low address bits 8-15 = Lock/bytes JEDEC-plane physical high address bits 16-23 = "n" such that 2 <sup>n</sup> = factory pre-programmed bytes bits 24-31 = "n" such that 2 <sup>n</sup> = user-programmable bytes	40:	--00	00h

**NOTE:**

- The variable P is a pointer which is defined at CFI offset 15h.

**Table 14. Burst Read Information**

Offset <sup>(1)</sup> P = 31h	Length	Description (Optional Flash Features and Commands)	Add.	Hex Code	Value
(P+13)h	1	Page Mode Read capability bits 0–7 = "n" such that 2 <sup>n</sup> HEX value represents the number of read-page bytes. See offset 28h for device word width to determine page-mode data output width. 00h indicates no read page buffer.	44:	--03	8 byte
(P+14)h	1	Number of synchronous mode read configuration fields that follow. 00h indicates no burst capability.	45:	--00	0
(P+15)h		<i>Reserved for future use</i>	46:		

**NOTE:**

- The variable P is a pointer which is defined at CFI offset 15h.

## 4.3 Read Identifier Codes Command

The identifier code operation is initiated by writing the Read Identifier Codes command. Following the command write, read cycles from addresses shown in [Figure 5 on page 10](#) retrieve the manufacturer, device and block lock configuration codes (see [Table 15](#) for identifier code values). Page-mode reads are not supported in this read mode. To terminate the operation, write another valid command. Like the Read Array command, the Read Identifier Codes command functions independently of the V<sub>PEN</sub> voltage. This command is valid only when the WSM is off or the device is suspended. Following the Read Identifier Codes command, the following information can be read:

Table 15. Identifier Codes

Code		Address <sup>(1)</sup>	Data
Manufacture Code		00000	(00) 89
Device Code	32-Mbit	00001	(00) 16
	64-Mbit	00001	(00) 17
	128-Mbit	00001	(00) 18
Block Lock Configuration		x0002 <sup>(2)</sup>	
• Block Is Unlocked			DQ <sub>0</sub> = 0
• Block Is Locked			DQ <sub>0</sub> = 1
• Reserved for Future Use			DQ <sub>1-7</sub>

**NOTES:**

1. A<sub>0</sub> is not used in either x8 or x16 modes when obtaining the identifier codes. The lowest order address line is A<sub>1</sub>. Data is always presented on the low byte in x16 mode (upper byte contains 00h).
2. X selects the specific block's lock configuration code. See [Figure 5](#) for the device identifier code memory map.

## 4.4 Read Status Register Command

The status register may be read to determine when a block erase, program, or lock-bit configuration is complete and whether the operation completed successfully. It may be read at any time by writing the Read Status Register command. After writing this command, all subsequent read operations output data from the status register until another valid command is written. Page-mode reads are not supported in this read mode. The status register contents are latched on the falling edge of OE# or the first edge of CE<sub>0</sub>, CE<sub>1</sub>, or CE<sub>2</sub> that enables the device (see [Table 2, “Chip Enable Truth Table” on page 7](#)). OE# must toggle to V<sub>IH</sub> or the device must be disabled (see [Table 2](#)) before further reads to update the status register latch. The Read Status Register command functions independently of the V<sub>PEN</sub> voltage.

During a program, block erase, set lock-bit, or clear lock-bit command sequence, only SR.7 is valid until the Write State Machine completes or suspends the operation. Device I/O pins DQ<sub>0</sub>–DQ<sub>6</sub> and DQ<sub>8</sub>–DQ<sub>15</sub> are placed in a high-impedance state. When the operation completes or suspends (check status register bit 7), all contents of the status register are valid when read.

**Table 16. Status Register Definitions**

WSMS	ESS	ECLBS	PSLBS	VPENS	PSS	DPS	R
bit 7	bit 6	bit 5	bit 4	bit 3	bit 2	bit 1	bit 0
<b>High Z When Busy?</b>	<b>Status Register Bits</b>				<b>Notes</b>		
<b>No</b>	SR.7 = WRITE STATE MACHINE STATUS 1 = Ready 0 = Busy				<p>Check STS or SR.7 to determine block erase, program, or lock-bit configuration completion. SR.6–SR.0 are not driven while SR.7 = “0.”</p> <p>If both SR.5 and SR.4 are “1”s after a block erase or lock-bit configuration attempt, an improper command sequence was entered.</p> <p>SR.3 does not provide a continuous programming voltage level indication. The WSM interrogates and indicates the programming voltage level only after Block Erase, Program, Set Block Lock-Bit, or Clear Block Lock-Bits command sequences.</p> <p>SR.1 does not provide a continuous indication of block lock-bit values. The WSM interrogates the block lock-bits only after Block Erase, Program, or Lock-Bit configuration command sequences. It informs the system, depending on the attempted operation, if the block lock-bit is set. Read the block lock configuration codes using the Read Identifier Codes command to determine block lock-bit status.</p> <p>SR.0 is reserved for future use and should be masked when polling the status register.</p>		
<b>Yes</b>	SR.6 = ERASE SUSPEND STATUS 1 = Block Erase Suspended 0 = Block Erase in Progress/Completed						
<b>Yes</b>	SR.5 = ERASE AND CLEAR LOCK-BITS STATUS 1 = Error in Block Erasure or Clear Lock-Bits 0 = Successful Block Erase or Clear Lock-Bits						
<b>Yes</b>	SR.4 = PROGRAM AND SET LOCK-BIT STATUS 1 = Error in Setting Lock-Bit 0 = Successful Set Block Lock Bit						
<b>Yes</b>	SR.3 = PROGRAMMING VOLTAGE STATUS 1 = Low Programming Voltage Detected, Operation Aborted 0 = Programming Voltage OK						
<b>Yes</b>	SR.2 = PROGRAM SUSPEND STATUS 1 = Program suspended 0 = Program in progress/completed						
<b>Yes</b>	SR.1 = DEVICE PROTECT STATUS 1 = Block Lock-Bit Detected, Operation Abort 0 = Unlock						
<b>Yes</b>	SR.0 = RESERVED FOR FUTURE ENHANCEMENTS						

**Table 17. eXtended Status Register Definitions**

WBS	<b>Reserved</b>	
bit 7	<b>bits 6—0</b>	
<b>High Z When Busy?</b>	<b>Status Register Bits</b>	<b>Notes</b>
<b>No</b>	XSR.7 = WRITE BUFFER STATUS 1 = Write buffer available 0 = Write buffer not available	<p>After a Buffer-Write command, XSR.7 = 1 indicates that a Write Buffer is available.</p> <p>SR.6–SR.0 are reserved for future use and should be masked when polling the status register.</p>
<b>Yes</b>	XSR.6–XSR.0 = RESERVED FOR FUTURE ENHANCEMENTS	

## 4.5 Clear Status Register Command

Status register bits SR.5, SR.4, SR.3, and SR.1 are set to “1”s by the WSM and can only be reset by the Clear Status Register command. These bits indicate various failure conditions (see [Table 16](#)). By allowing system software to reset these bits, several operations (such as cumulatively erasing or locking multiple blocks or writing several bytes in sequence) may be performed. The status register may be polled to determine if an error occurred during the sequence.

To clear the status register, the Clear Status Register command (50H) is written. It functions independently of the applied  $V_{PEN}$  voltage. The Clear Status Register command is only valid when the WSM is off or the device is suspended.

## 4.6 Block Erase Command

Erase is executed one block at a time and initiated by a two-cycle command. A block erase setup is first written, followed by an block erase confirm. This command sequence requires an appropriate address within the block to be erased (erase changes all block data to FFH). Block preconditioning, erase, and verify are handled internally by the WSM (invisible to the system). After the two-cycle block erase sequence is written, the device automatically outputs status register data when read (see [Figure 10, “Block Erase Flowchart” on page 33](#)). The CPU can detect block erase completion by analyzing the output of the STS pin or status register bit SR.7. Toggle OE#, CE<sub>0</sub>, CE<sub>1</sub>, or CE<sub>2</sub> to update the status register.

When the block erase is complete, status register bit SR.5 should be checked. If a block erase error is detected, the status register should be cleared before system software attempts corrective actions. The CUI remains in read status register mode until a new command is issued.

This two-step command sequence of set-up followed by execution ensures that block contents are not accidentally erased. An invalid Block Erase command sequence will result in both status register bits SR.4 and SR.5 being set to “1.” Also, reliable block erasure can only occur when  $V_{CC}$  is valid and  $V_{PEN} = V_{PENH}$ . If block erase is attempted while  $V_{PEN} \leq V_{PENLK}$ , SR.3 and SR.5 will be set to “1.” Successful block erase requires that the corresponding block lock-bit be cleared. If block erase is attempted when the corresponding block lock-bit is set, SR.1 and SR.5 will be set to “1.”

## 4.7 Block Erase Suspend Command

The Block Erase Suspend command allows block-erase interruption to read or program data in another block of memory. Once the block erase process starts, writing the Block Erase Suspend command requests that the WSM suspend the block erase sequence at a predetermined point in the algorithm. The device outputs status register data when read after the Block Erase Suspend command is written. Polling status register bit SR.7 then SR.6 can determine when the block erase operation has been suspended (both will be set to “1”). In default mode, STS will also transition to  $V_{OH}$ . Specification  $t_{WHRH}$  defines the block erase suspend latency.

At this point, a Read Array command can be written to read data from blocks other than that which is suspended. A program command sequence can also be issued during erase suspend to program data in other blocks. During a program operation with block erase suspended, status register bit SR.7 will return to “0” and STS output (in default mode) will transition to  $V_{OL}$ . However, SR.6 will remain “1” to indicate block erase suspend status. Using the Program Suspend command, a program operation can also be suspended. Resuming a suspended programming operation by

issuing the Program Resume command allows continuing of the suspended programming operation. To resume the suspended erase, the user must wait for the programming operation to complete before issuing the Block Erase Resume command.

The only other valid commands while block erase is suspended are Read Query, Read Status Register, Clear Status Register, Configure, and Block Erase Resume. After a Block Erase Resume command is written to the flash memory, the WSM will continue the block erase process. Status register bits SR.6 and SR.7 will automatically clear and STS (in default mode) will return to  $V_{OL}$ . After the Erase Resume command is written, the device automatically outputs status register data when read (see [Figure 11, “Block Erase Suspend/Resume Flowchart”](#) on page 34).  $V_{PEN}$  must remain at  $V_{PENH}$  (the same  $V_{PEN}$  level used for block erase) while block erase is suspended. Block erase cannot resume until program operations initiated during block erase suspend have completed.

## 4.8 Write to Buffer Command

To program the flash device, a Write to Buffer command sequence is initiated. A variable number of bytes, up to the buffer size, can be loaded into the buffer and written to the flash device. First, the Write to Buffer Setup command is issued along with the Block Address (see [Figure 7, “Write to Buffer Flowchart”](#) on page 30). At this point, the eXtended Status Register (XSR, see [Table 17](#)) information is loaded and XSR.7 reverts to “buffer available” status. If XSR.7 = 0, the write buffer is not available. To retry, continue monitoring XSR.7 by issuing the Write to Buffer setup command with the Block Address until XSR.7 = 1. When XSR.7 transitions to a “1,” the buffer is ready for loading.

Now a word/byte count is given to the part with the Block Address. On the next write, a device start address is given along with the write buffer data. Subsequent writes provide additional device addresses and data, depending on the count. All subsequent addresses must lie within the start address plus the count.

Internally, this device programs many flash cells in parallel. Because of this parallel programming, maximum programming performance and lower power are obtained by aligning the start address at the beginning of a write buffer boundary (i.e.,  $A_4-A_0$  of the start address = 0).

After the final buffer data is given, a Write Confirm command is issued. This initiates the WSM (Write State Machine) to begin copying the buffer data to the flash array. If a command other than Write Confirm is written to the device, an “Invalid Command/Sequence” error will be generated and Status Register bits SR.5 and SR.4 will be set to a “1.” For additional buffer writes, issue another Write to Buffer Setup command and check XSR.7.

If an error occurs while writing, the device will stop writing, and status register bit SR.4 will be set to a “1” to indicate a program failure. The internal WSM verify only detects errors for “1”s that do not successfully program to “0”s. If a program error is detected, the status register should be cleared. Any time SR.4 and/or SR.5 is set (e.g., a media failure occurs during a program or an erase), the device will not accept any more Write to Buffer commands. Additionally, if the user attempts to program past an erase block boundary with a Write to Buffer command, the device will abort the write to buffer operation. This will generate an “Invalid Command/Sequence” error and status register bits SR.5 and SR.4 will be set to a “1.”

Reliable buffered writes can only occur when  $V_{PEN} = V_{PENH}$ . If a buffered write is attempted while  $V_{PEN} \leq V_{PENLK}$ , status register bits SR.4 and SR.3 will be set to “1.” Buffered write attempts with invalid  $V_{CC}$  and  $V_{PEN}$  voltages produce spurious results and should not be attempted. Finally, successful programming requires that the corresponding block lock-bit be reset. If a buffered write is attempted when the corresponding block lock-bit is set, SR.1 and SR.4 will be set to “1.”

## 4.9 Byte/Word Program Commands

Byte/Word program is executed by a two-cycle command sequence. Byte/Word program setup (standard 40H or alternate 10H) is written followed by a second write that specifies the address and data (latched on the rising edge of WE#). The WSM then takes over, controlling the program and program verify algorithms internally. After the program sequence is written, the device automatically outputs status register data when read (see [Figure 8, “Byte/Word Program Flowchart” on page 31](#)). The CPU can detect the completion of the program event by analyzing the STS pin or status register bit SR.7.

When program is complete, status register bit SR.4 should be checked. If a program error is detected, the status register should be cleared. The internal WSM verify only detects errors for “1”s that do not successfully program to “0”s. The CUI remains in read status register mode until it receives another command.

Reliable byte/word programs can only occur when  $V_{CC}$  and  $V_{PEN}$  are valid. If a byte/word program is attempted while  $V_{PEN} \leq V_{PENLK}$ , status register bits SR.4 and SR.3 will be set to “1.” Successful byte/word programs require that the corresponding block lock-bit be cleared. If a byte/word program is attempted when the corresponding block lock-bit is set, SR.1 and SR.4 will be set to “1.”

## 4.10 Program Suspend Command

The Program Suspend command allows program interruption to read data in other flash memory locations. Once the programming process starts (either by initiating a write to buffer or byte/word program operation), writing the Program Suspend command requests that the WSM suspend the program sequence at a predetermined point in the algorithm. The device continues to output status register data when read after the Program Suspend command is written. Polling status register bits SR.7 can determine when the programming operation has been suspended. When SR.7 = 1, SR.2 should also be set to “1”, indicating that the device is in the program suspend mode. STS in level RY/BY# mode will also transition to  $V_{OH}$ . Specification  $t_{WHRH1}$  defines the program suspend latency.

At this point, a Read Array command can be written to read data from locations other than that which is suspended. The only other valid commands while programming is suspended are Read Query, Read Status Register, Clear Status Register, Configure, and Program Resume. After a Program Resume command is written, the WSM will continue the programming process. Status register bits SR.2 and SR.7 will automatically clear and STS in RY/BY# mode will return to  $V_{OL}$ . After the Program Resume command is written, the device automatically outputs status register data when read.  $V_{PEN}$  must remain at  $V_{PENH}$  and  $V_{CC}$  must remain at valid  $V_{CC}$  levels (the same  $V_{PEN}$  and  $V_{CC}$  levels used for programming) while in program suspend mode. Refer to [Figure 9, “Program Suspend/Resume Flowchart” on page 32](#).

## 4.11 Set Read Configuration Command

This command is not support on this product. This device will default to the asynchronous page mode. If this command is given to the device it will not effect the operation of the device.

### 4.11.1 Read Configuration

The device will support both asynchronous page mode and standard word/byte reads. No configuration is required.

Status register and identifier only support standard word/byte single read operations.

**Table 18. Read Configuration Register Definition**

RM	R	R	R	R	R	R	R
16 (A <sub>16</sub> )	15	14	13	12	11	10	9
R	R	R	R	R	R	R	R
8	7	6	5	4	3	2	1
				<b>Notes</b>			
RCR.16 = READ MODE (RM) 0 = Standard Word/Byte Reads Enabled (Default) 1 = Page-Mode Reads Enabled				Read mode configuration effects reads from the flash array. Status register, query, and identifier reads support standard word/byte read cycles.			
RCR.15–1 = RESERVED FOR FUTURE ENHANCEMENTS (R)				These bits are reserved for future use. Set these bits to “0.”			

### 4.12 Configuration Command

The Status (STS) pin can be configured to different states using the Configuration command. Once the STS pin has been configured, it remains in that configuration until another configuration command is issued or RP# is asserted low. Initially, the STS pin defaults to RY/BY# operation where RY/BY# low indicates that the state machine is busy. RY/BY# high indicates that the state machine is ready for a new operation or suspended. [Table 19, “Configuration Coding Definitions” on page 26](#) displays the possible STS configurations.

To reconfigure the Status (STS) pin to other modes, the Configuration command is given followed by the desired configuration code. The three alternate configurations are all pulse mode for use as a system interrupt as described below. For these configurations, bit 0 controls Erase Complete interrupt pulse, and bit 1 controls Program Complete interrupt pulse. Supplying the 00h configuration code with the Configuration command resets the STS pin to the default RY/BY# level mode. The possible configurations and their usage are described in [Table 19, “Configuration Coding Definitions” on page 26](#). The Configuration command may only be given when the device is not busy or suspended. Check SR.7 for device status. An invalid configuration code will result in both status register bits SR.4 and SR.5 being set to “1.” When configured in one of the pulse modes, the STS pin pulses low with a typical pulse width of 250 ns.

Table 19. Configuration Coding Definitions

Reserved	Pulse on Program Complete <sup>(1)</sup>	Pulse on Erase Complete <sup>(1)</sup>
bits 7—2	bit 1	bit 0
DQ <sub>7</sub> _DQ <sub>2</sub> = Reserved DQ <sub>1</sub> _DQ <sub>0</sub> = STS Pin Configuration Codes 00 = default, level mode RY/BY# (device ready) indication 01 = pulse on Erase complete 10 = pulse on Program complete 11 = pulse on Erase or Program Complete Configuration Codes 01b, 10b, and 11b are all pulse mode such that the STS pin pulses low then high when the operation indicated by the given configuration is completed. Configuration Command Sequences for STS pin configuration (masking bits DQ <sub>7</sub> _DQ <sub>2</sub> to 00h) are as follows: Default RY/BY# level mode: B8h, 00h ER INT (Erase Interrupt): B8h, 01h Pulse-on-Erase Complete PR INT (Program Interrupt): B8h, 02h Pulse-on-Program Complete ER/PR INT (Erase or Program Interrupt): B8h, 03h Pulse-on-Erase or Program Complete	DQ <sub>7</sub> _DQ <sub>2</sub> are reserved for future use. default (DQ <sub>1</sub> _DQ <sub>0</sub> = 00) RY/BY#, level mode — used to control HOLD to a memory controller to prevent accessing a flash memory subsystem while any flash device's WSM is busy. configuration 01 ER INT, pulse mode — used to generate a system interrupt pulse when any flash device in an array has completed a Block Erase. Helpful for reformatting blocks after file system free space reclamation or “cleanup” configuration 10 PR INT, pulse mode — used to generate a system interrupt pulse when any flash device in an array has complete a Program operation. Provides highest performance for servicing continuous buffer write operations. configuration 11 ER/PR INT, pulse mode — used to generate system interrupts to trigger servicing of flash arrays when either erase or program operations are completed when a common interrupt service routine is desired.	

**NOTE:** 1. When the device is configured in one of the pulse modes, the STS pin pulses low with a typical pulse width of 250 ns.

## 4.13 Set Block Lock-Bit Commands

A flexible block locking and unlocking scheme is enabled via block lock-bits. The block lock-bits gate program and erase operations. Individual block lock-bits can be set using the Set Block Lock-Bit command. This command is invalid while the WSM is running or the device is suspended.

Set block lock-bit commands are executed by a two-cycle sequence. The set block setup along with appropriate block address is followed by either the set block lock-bit confirm (and an address within the block to be locked). The WSM then controls the set lock-bit algorithm. After the sequence is written, the device automatically outputs status register data when read (see [Figure 12 on page 35](#)). The CPU can detect the completion of the set lock-bit event by analyzing the STS pin output or status register bit SR.7.

When the set lock-bit operation is complete, status register bit SR.4 should be checked. If an error is detected, the status register should be cleared. The CUI will remain in read status register mode until a new command is issued.

This two-step sequence of set-up followed by execution ensures that lock-bits are not accidentally set. An invalid Set Block Lock-Bit command will result in status register bits SR.4 and SR.5 being set to “1.” Also, reliable operations occur only when  $V_{CC}$  and  $V_{PEN}$  are valid. With  $V_{PEN} \leq V_{PENLK}$ , lock-bit contents are protected against alteration.

## 4.14 Clear Block Lock-Bits Command

All set block lock-bits are cleared in parallel via the Clear Block Lock-Bits command. Block lock-bits can be cleared using only the Clear Block Lock-Bits command. This command is invalid while the WSM is running or the device is suspended.

Clear block lock-bits command is executed by a two-cycle sequence. A clear block lock-bits setup is first written. The device automatically outputs status register data when read (see [Figure 13 on page 36](#)). The CPU can detect completion of the clear block lock-bits event by analyzing the STS pin output or status register bit SR.7.

When the operation is complete, status register bit SR.5 should be checked. If a clear block lock-bit error is detected, the status register should be cleared. The CUI will remain in read status register mode until another command is issued.

This two-step sequence of set-up followed by execution ensures that block lock-bits are not accidentally cleared. An invalid Clear Block Lock-Bits command sequence will result in status register bits SR.4 and SR.5 being set to “1.” Also, a reliable clear block lock-bits operation can only occur when  $V_{CC}$  and  $V_{PEN}$  are valid. If a clear block lock-bits operation is attempted while  $V_{PEN} \leq V_{PENLK}$ , SR.3 and SR.5 will be set to “1.”

If a clear block lock-bits operation is aborted due to  $V_{PEN}$  or  $V_{CC}$  transitioning out of valid range, block lock-bit values are left in an undetermined state. A repeat of clear block lock-bits is required to initialize block lock-bit contents to known values.

## 4.15 Protection Register Program Command

The 3 Volt Intel StrataFlash memory includes a 128-bit protection register that can be used to increase the security of a system design. For example, the number contained in the protection register can be used to “mate” the flash component with other system components such as the CPU or ASIC, preventing device substitution.

The 128-bits of the protection register are divided into two 64-bit segments. One of the segments is programmed at the Intel factory with a unique 64-bit number, which is unchangeable. The other segment is left blank for customer designers to program as desired. Once the customer segment is programmed, it can be locked to prevent reprogramming.

### 4.15.1 Reading the Protection Register

The protection register is read in the identification read mode. The device is switched to this mode by writing the Read Identifier command (90H). Once in this mode, read cycles from addresses shown in [Table 20](#) or [Table 21](#) retrieve the specified information. To return to read array mode, write the Read Array command (FFH).

### 4.15.2 Programming the Protection Register

The protection register bits are programmed using the two-cycle Protection Program command. The 64-bit number is programmed 16 bits at a time for word-wide parts and eight bits at a time for byte-wide parts. First write the Protection Program Setup command, C0H. The next write to the

device will latch in address and data and program the specified location. The allowable addresses are shown in Table 20 or Table 21. See Figure 14, “Protection Register Programming Flowchart” on page 37

Any attempt to address Protection Program commands outside the defined protection register address space will result in a status register error (program error bit SR.4 will be set to 1). Attempting to program a locked protection register segment will result in a status register error (program error bit SR.4 and lock error bit SR.1 will be set to 1).

### 4.15.3 Locking the Protection Register

The user-programmable segment of the protection register is lockable by programming Bit 1 of the PR-LOCK location to 0. Bit 0 of this location is programmed to 0 at the Intel factory to protect the unique device number. Bit 1 is set using the Protection Program command to program “FFFD” to the PR-LOCK location. After these bits have been programmed, no further changes can be made to the values stored in the protection register. Protection Program commands to a locked section will result in a status register error (program error bit SR.4 and Lock Error bit SR.1 will be set to 1). Protection register lockout state is not reversible.

Figure 6. Protection Register Memory Map

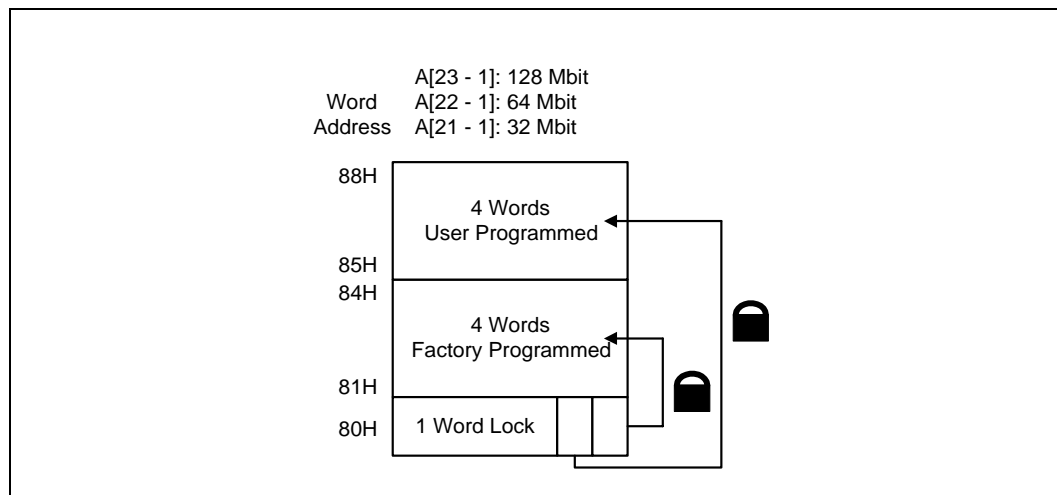

**NOTE:** A<sub>0</sub> is not used in x16 mode when accessing the protection register map (See Table 20 for x16 addressing). For x8 mode A<sub>0</sub> is used (See Table 21 for x8 addressing).

0667\_06

**Table 20. Word-Wide Protection Register Addressing**

Word	Use	A8	A7	A6	A5	A4	A3	A2	A1
LOCK	Both	1	0	0	0	0	0	0	0
0	Factory	1	0	0	0	0	0	0	1
1	Factory	1	0	0	0	0	0	1	0
2	Factory	1	0	0	0	0	0	1	1
3	Factory	1	0	0	0	0	1	0	0
4	User	1	0	0	0	0	1	0	1
5	User	1	0	0	0	0	1	1	0
6	User	1	0	0	0	0	1	1	1
7	User	1	0	0	0	1	0	0	0

**NOTE:** 1. All address lines not specified in the above table must be 0 when accessing the Protection Register, i.e.,  $A_{23}-A_9 = 0$ .

**Table 21. Byte-Wide Protection Register Addressing**

Byte	Use	A8	A7	A6	A5	A4	A3	A2	A1
LOCK	Both	1	0	0	0	0	0	0	0
LOCK	Both	1	0	0	0	0	0	0	0
0	Factory	1	0	0	0	0	0	0	1
1	Factory	1	0	0	0	0	0	0	1
2	Factory	1	0	0	0	0	0	1	0
3	Factory	1	0	0	0	0	0	1	0
4	Factory	1	0	0	0	0	0	1	1
5	Factory	1	0	0	0	0	0	1	1
6	Factory	1	0	0	0	0	1	0	0
7	Factory	1	0	0	0	0	1	0	0
8	User	1	0	0	0	0	1	0	1
9	User	1	0	0	0	0	1	0	1
A	User	1	0	0	0	0	1	1	0
B	User	1	0	0	0	0	1	1	0
C	User	1	0	0	0	0	1	1	1
D	User	1	0	0	0	0	1	1	1
E	User	1	0	0	0	1	0	0	0
F	User	1	0	0	0	1	0	0	0

**NOTE:** 1. All address lines not specified in the above table must be 0 when accessing the Protection Register, i.e.,  $A_{23}-A_9 = 0$ .

Figure 7. Write to Buffer Flowchart

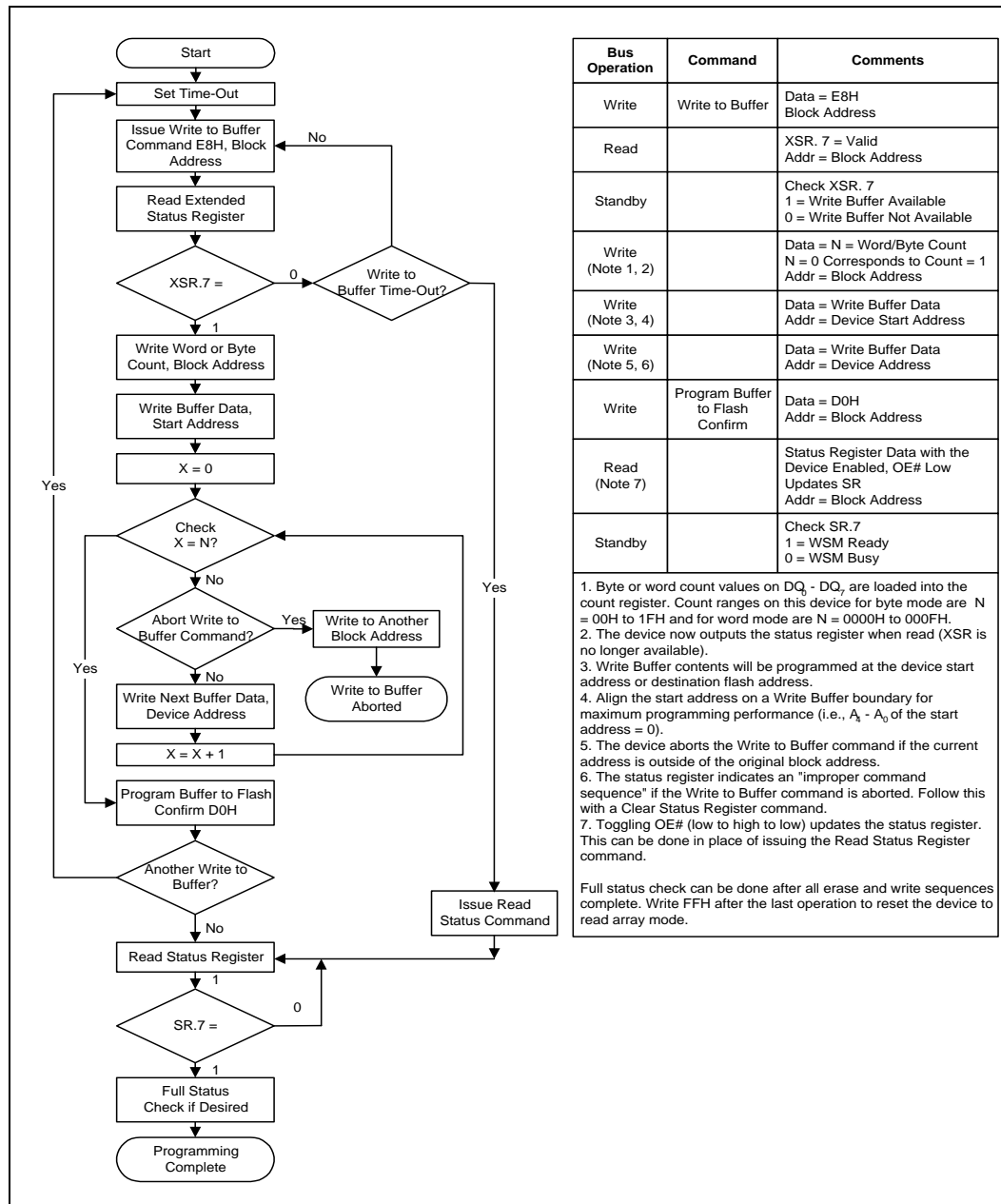

0606\_07A

Figure 8. Byte/Word Program Flowchart

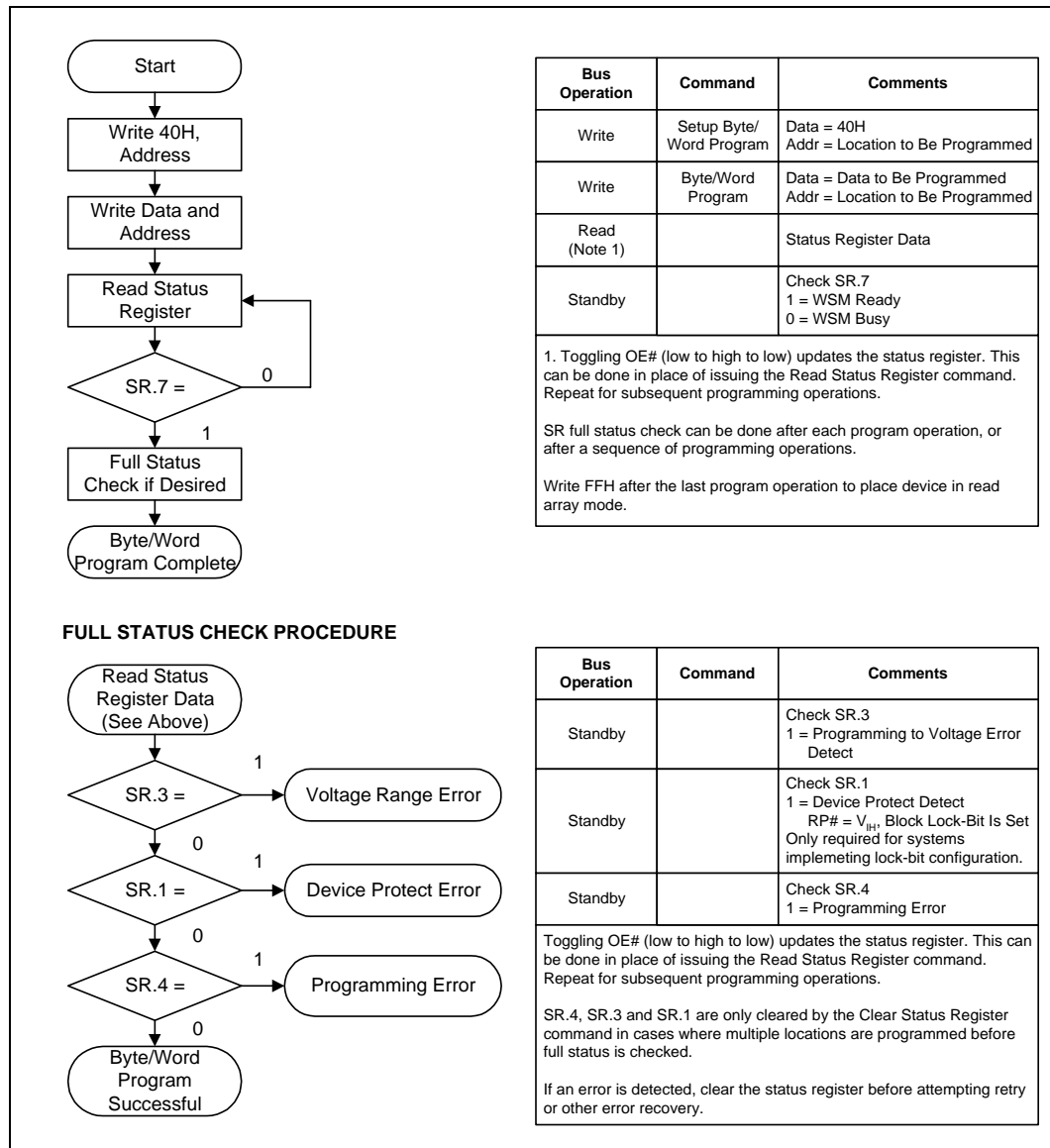
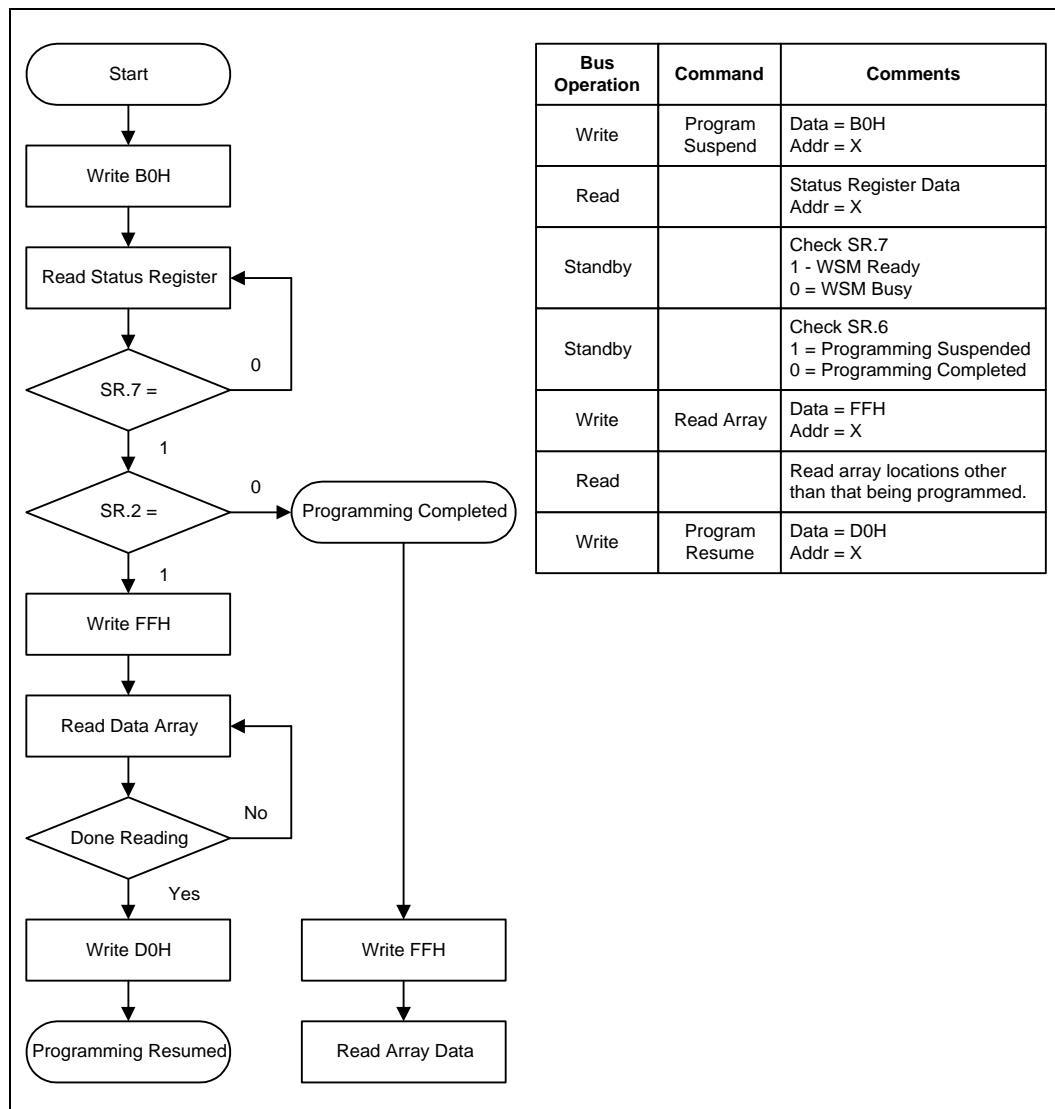
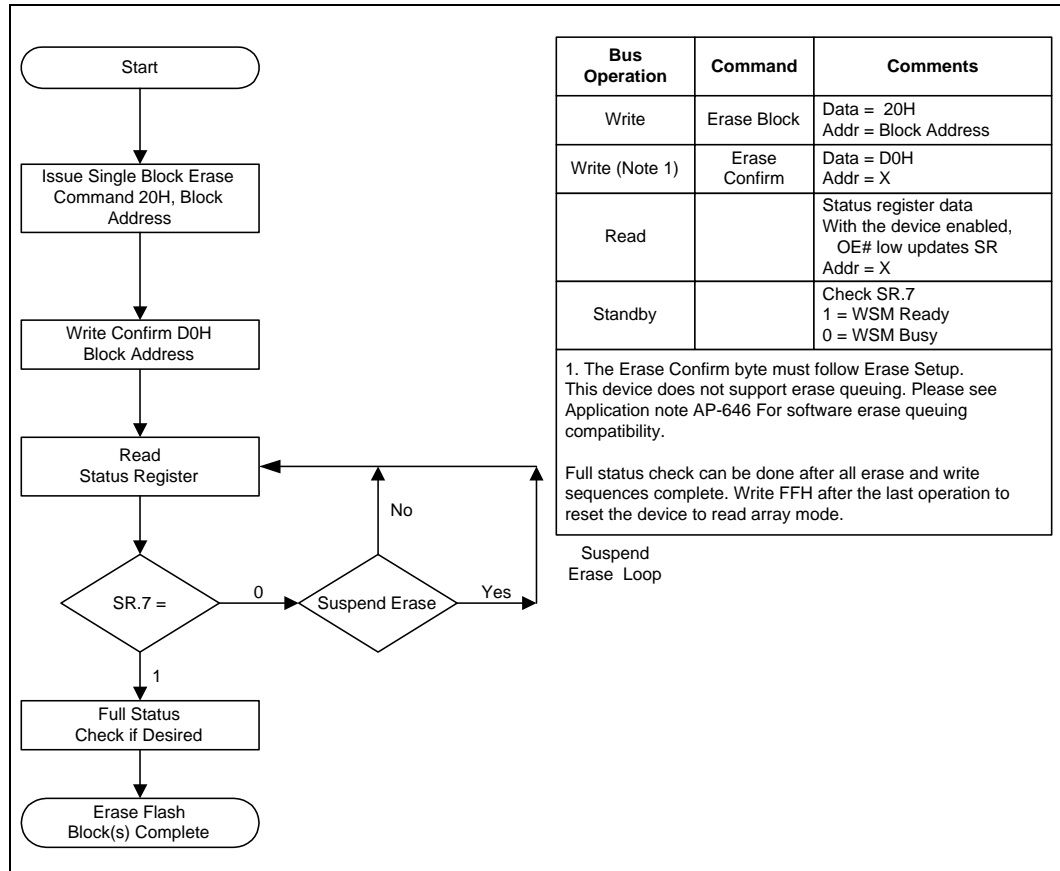

Figure 9. Program Suspend/Resume Flowchart



0606\_08

Figure 10. Block Erase Flowchart



0606\_09

Figure 11. Block Erase Suspend/Resume Flowchart

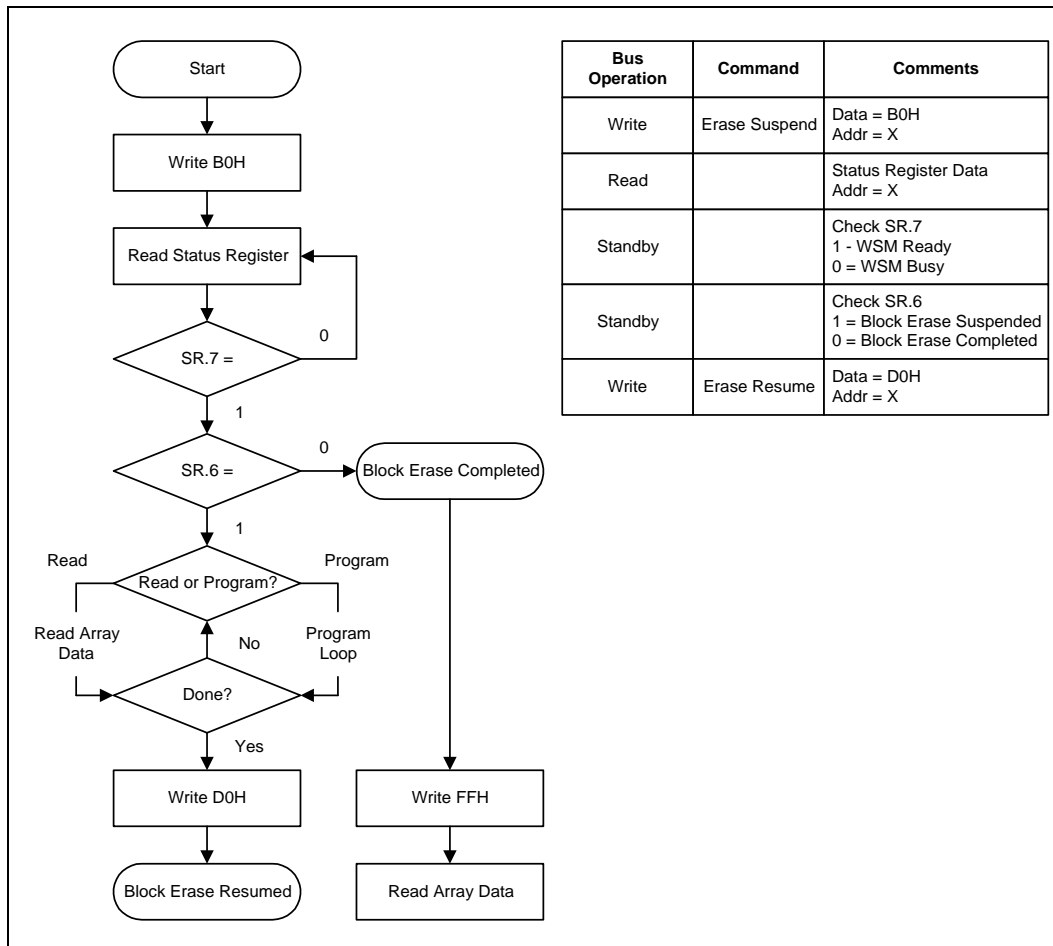

0606\_10

Figure 12. Set Block Lock-Bit Flowchart

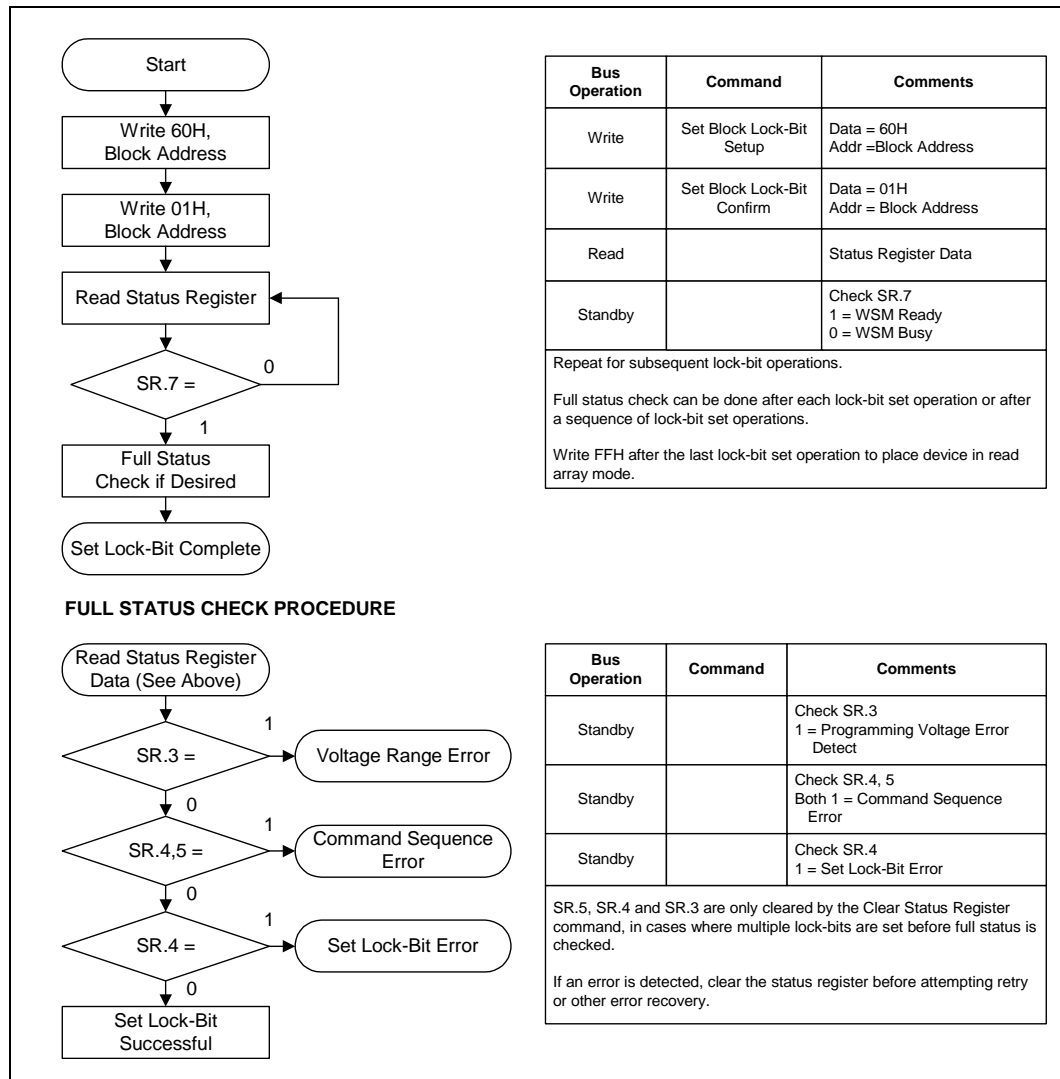

0606\_11b

Figure 13. Clear Lock-Bit Flowchart

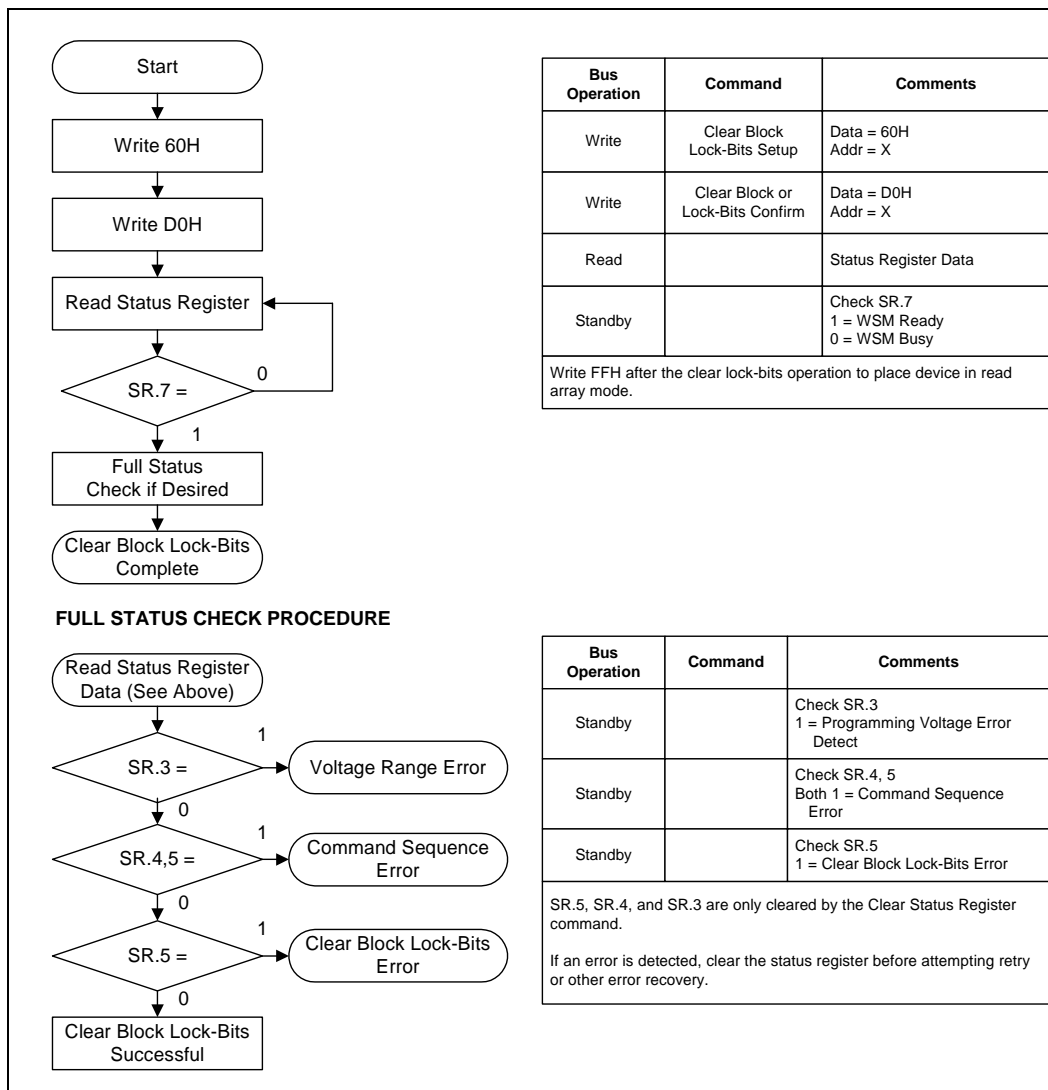

0606\_12b

Figure 14. Protection Register Programming Flowchart

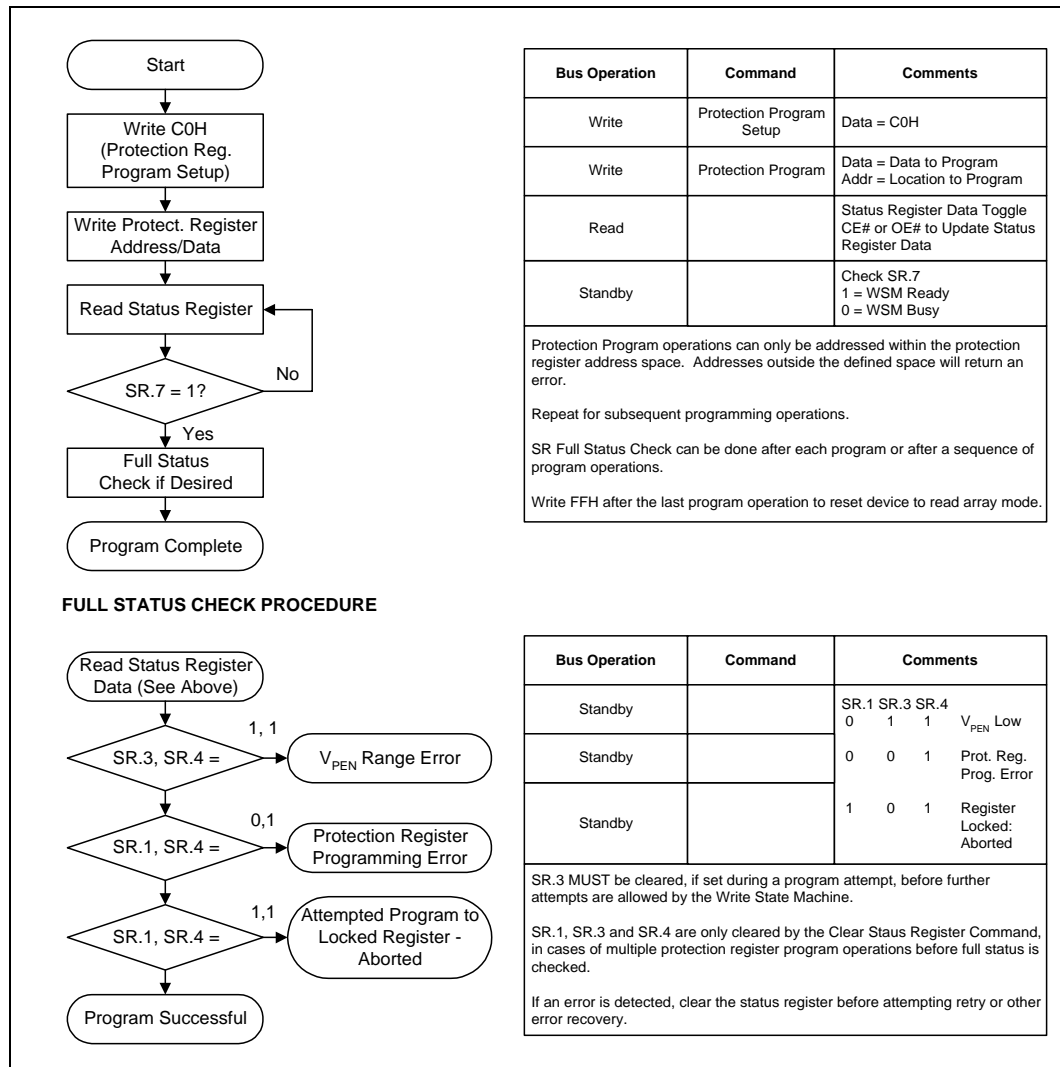

## 5.0 Design Considerations

---

### 5.1 Three-Line Output Control

The device will often be used in large memory arrays. Intel provides five control inputs ( $CE_0$ ,  $CE_1$ ,  $CE_2$ ,  $OE\#$ , and  $RP\#$ ) to accommodate multiple memory connections. This control provides for:

- a. Lowest possible memory power dissipation.
- b. Complete assurance that data bus contention will not occur.

To use these control inputs efficiently, an address decoder should enable the device (see [Table 2](#)) while  $OE\#$  should be connected to all memory devices and the system's  $READ\#$  control line. This assures that only selected memory devices have active outputs while de-selected memory devices are in standby mode.  $RP\#$  should be connected to the system  $POWERGOOD$  signal to prevent unintended writes during system power transitions.  $POWERGOOD$  should also toggle during system reset.

### 5.2 STS and Block Erase, Program, and Lock-Bit Configuration Polling

STS is an open drain output that should be connected to  $V_{CCQ}$  by a pull-up resistor to provide a hardware method of detecting block erase, program, and lock-bit configuration completion. It is recommended that a 2.5k resistor be used between  $STS\#$  and  $V_{CCQ}$ . In default mode, it transitions low after block erase, program, or lock-bit configuration commands and returns to High Z when the WSM has finished executing the internal algorithm. For alternate configurations of the STS pin, see the Configuration command.

STS can be connected to an interrupt input of the system CPU or controller. It is active at all times. STS, in default mode, is also High Z when the device is in block erase suspend (with programming inactive), program suspend, or in reset/power-down mode.

### 5.3 Power Supply Decoupling

Flash memory power switching characteristics require careful device decoupling. System designers are interested in three supply current issues; standby current levels, active current levels and transient peaks produced by falling and rising edges of  $CE_0$ ,  $CE_1$ ,  $CE_2$ , and  $OE\#$ . Transient current magnitudes depend on the device outputs' capacitive and inductive loading. Two-line control and proper decoupling capacitor selection will suppress transient voltage peaks. Since Intel StrataFlash memory devices draw their power from three  $V_{CC}$  pins (these devices do not include a  $V_{PP}$  pin), it is recommended that systems without separate power and ground planes attach a 0.1  $\mu F$  ceramic capacitor between each of the device's three  $V_{CC}$  pins (this includes  $V_{CCQ}$ ) and ground. These high-frequency, low-inductance capacitors should be placed as close as possible to package leads on each Intel StrataFlash memory device. Each device should have a 0.1  $\mu F$  ceramic capacitor connected between its  $V_{CC}$  and GND. These high-frequency, low inductance capacitors should be placed as close as possible to package leads. Additionally, for every eight devices, a 4.7  $\mu F$  electrolytic capacitor should be placed between  $V_{CC}$  and GND at the array's power supply connection. The bulk capacitor will overcome voltage slumps caused by PC board trace inductance.

## 5.4 Input Signal Transitions - Reducing Overshoots and Undershoots When Using Buffers or Transceivers

As faster, high-drive devices such as transceivers or buffers drive input signals to flash memory devices, overshoots and undershoots can sometimes cause input signals to exceed flash memory specifications. (See “Absolute Maximum Ratings” on page 40.) Many buffer/transceiver vendors now carry bus-interface devices with internal output-damping resistors or reduced-drive outputs. Internal output-damping resistors diminish the nominal output drive currents, while still leaving sufficient drive capability for most applications. These internal output-damping resistors help reduce unnecessary overshoots and undershoots. Transceivers or buffers with balanced- or light-drive outputs also reduce overshoots and undershoots by diminishing output-drive currents. When considering a buffer/transceiver interface design to flash, devices with internal output-damping resistors or reduced-drive outputs should be used to minimize overshoots and undershoots. For additional information, please refer to the *AP-647 5 Volt Intel StrataFlash™ Memory Design Guide*.

## 5.5 $V_{CC}$ , $V_{PEN}$ , RP# Transitions

Block erase, program, and lock-bit configuration are not guaranteed if  $V_{PEN}$  or  $V_{CC}$  falls outside of the specified operating ranges, or  $RP\# \neq V_{IH}$ . If  $RP\#$  transitions to  $V_{IL}$  during block erase, program, or lock-bit configuration, STS (in default mode) will remain low for a maximum time of  $t_{PLPH} + t_{PHRH}$  until the reset operation is complete. Then, the operation will abort and the device will enter reset/power-down mode. The aborted operation may leave data partially corrupted after programming, or partially altered after an erase or lock-bit configuration. Therefore, block erase and lock-bit configuration commands must be repeated after normal operation is restored. Device power-off or  $RP\# = V_{IL}$  clears the status register.

The CUI latches commands issued by system software and is not altered by  $V_{PEN}$ ,  $CE_0$ ,  $CE_1$ , or  $CE_2$  transitions, or WSM actions. Its state is read array mode upon power-up, after exit from reset/power-down mode, or after  $V_{CC}$  transitions below  $V_{LKO}$ .  $V_{CC}$  must be kept at or above  $V_{PEN}$  during  $V_{CC}$  transitions.

After block erase, program, or lock-bit configuration, even after  $V_{PEN}$  transitions down to  $V_{PENLK}$ , the CUI must be placed in read array mode via the Read Array command if subsequent access to the memory array is desired.  $V_{PEN}$  must be kept at or below  $V_{CC}$  during  $V_{PEN}$  transitions.

## 5.6 Power-Up/Down Protection

The device is designed to offer protection against accidental block erasure, programming, or lock-bit configuration during power transitions. Internal circuitry resets the CUI to read array mode at power-up.

A system designer must guard against spurious writes for  $V_{CC}$  voltages above  $V_{LKO}$  when  $V_{PEN}$  is active. Since  $WE\#$  must be low and the device enabled (see [Table 2](#)) for a command write, driving  $WE\#$  to  $V_{IH}$  or disabling the device will inhibit writes. The CUI's two-step command sequence architecture provides added protection against data alteration.

Keeping  $V_{PEN}$  below  $V_{PENLK}$  prevents inadvertent data alteration. In-system block lock and unlock capability protects the device against inadvertent programming. The device is disabled while  $RP\# = V_{IL}$  regardless of its control inputs.

## 5.7 Power Dissipation

When designing portable systems, designers must consider battery power consumption not only during device operation, but also for data retention during system idle time. Flash memory's nonvolatility increases usable battery life because data is retained when system power is removed.

## 6.0 Electrical Specifications

---

### 6.1 Absolute Maximum Ratings

Parameter	Maximum Rating
Temperature under Bias Expanded	-25 °C to +85 °C
Storage Temperature	-65 °C to +125 °C
Voltage On Any Pin	-2.0 V to +5.0 V <sup>(1)</sup>
Output Short Circuit Current	100 mA <sup>(2)</sup>

**NOTES:**

1. All specified voltages are with respect to GND. Minimum DC voltage is -0.5 V on input/output pins and -0.2 V on  $V_{CC}$  and  $V_{PEN}$  pins. During transitions, this level may undershoot to -2.0 V for periods <20 ns. Maximum DC voltage on input/output pins,  $V_{CC}$ , and  $V_{PEN}$  is  $V_{CC} + 0.5$  V which, during transitions, may overshoot to  $V_{CC} + 2.0$  V for periods <20 ns.
2. Output shorted for no more than one second. No more than one output shorted at a time.

NOTICE: This datasheet contains preliminary information on new products in production. The specifications are subject to change without notice. Verify with your local Intel Sales office that you have the latest datasheet before finalizing a design.

**Warning:** Stressing the device beyond the “Absolute Maximum Ratings” may cause permanent damage. These are stress ratings only. Operation beyond the “Operating Conditions” is not recommended and extended exposure beyond the “Operating Conditions” may affect device reliability.

## 6.2 Operating Conditions

**Table 22. Temperature and  $V_{CC}$  Operating Conditions**

Symbol	Parameter	Notes	Min	Max	Unit	Test Condition
$T_A$	Operating Temperature		-25	+85	°C	Ambient Temperature
$V_{CC1}$	$V_{CC1}$ Supply Voltage (2.7 V–3.6 V)		2.70	3.60	V	
$V_{CC2}$	$V_{CC2}$ Supply Voltage (3.0 V–3.6 V)		3.00	3.60	V	
$V_{CCQ1}$	$V_{CCQ1}$ Supply Voltage (2.7 V–3.6 V)		2.70	3.60	V	
$V_{CCQ2}$	$V_{CCQ2}$ Supply Voltage (3.0 V–3.6 V)		3.00	3.60	V	

## 6.3 Capacitance

$T_A = +25\text{ °C}$ ,  $f = 1\text{ MHz}$

Symbol	Parameter <sup>(1)</sup>	Typ	Max	Unit	Condition
$C_{IN}$	Input Capacitance	6	8	pF	$V_{IN} = 0.0\text{ V}$
$C_{OUT}$	Output Capacitance	8	12	pF	$V_{OUT} = 0.0\text{ V}$

**NOTES:**

1. Sampled, not 100% tested.

## 6.4 DC Characteristics

Symbol	Parameter	Notes	Typ	Max	Unit	Test Conditions
$I_{LI}$	Input and $V_{PEN}$ Load Current	1		$\pm 1$	$\mu A$	$V_{CC} = V_{CC} \text{ Max}; V_{CCQ} = V_{CCQ} \text{ Max}$ $V_{IN} = V_{CCQ} \text{ or GND}$
$I_{LO}$	Output Leakage Current	1		$\pm 10$	$\mu A$	$V_{CC} = V_{CC} \text{ Max}; V_{CCQ} = V_{CCQ} \text{ Max}$ $V_{IN} = V_{CCQ} \text{ or GND}$
$I_{LO}$	Output Leakage Current	1		$\pm 10$	$\mu A$	$V_{CC} = V_{CC} \text{ Max}; V_{CCQ} = V_{CCQ} \text{ Max}$ $V_{IN} = V_{CCQ} \text{ or GND}$
$I_{CCS}$	$V_{CC}$ Standby Current	1,2,3,4	50	120	$\mu A$	CMOS Inputs, $V_{CC} = V_{CC} \text{ Max}$ , Device is enabled (see Table 2, "Chip Enable Truth Table" on page 7), $RP\# = V_{CCQ} \pm 0.2 V$
			0.71	2	mA	TTL Inputs, $V_{CC} = V_{CC} \text{ Max}$ , Device is enabled (see Table 2), $RP\# = V_{IH}$
$I_{CCD}$	$V_{CC}$ Power-Down Current	4	50	120	$\mu A$	$RP\# = GND \pm 0.2 V, I_{OUT} (STS) = 0 \text{ mA}$
$I_{CCR}$	$V_{CC}$ Page Mode Read Current	1,3,4	15	20	mA	CMOS Inputs, $V_{CC} = V_{CC} \text{ Max}, V_{CCQ} = V_{CCQ} \text{ Max}$ using standard 4 word page mode reads. Device is enabled (see Table 2) $f = 5 \text{ MHz}, I_{OUT} = 0 \text{ mA}$
			24	29	mA	CMOS Inputs, $V_{CC} = V_{CC} \text{ Max}, V_{CCQ} = V_{CCQ} \text{ Max}$ using standard 4 word page mode reads. Device is enabled (see Table 2) $f = 33 \text{ MHz}, I_{OUT} = 0 \text{ mA}$
$I_{CCR}$	$V_{CC}$ Byte Mode Read Current	1,3,4	40	50	mA	CMOS Inputs, $V_{CC} = V_{CC} \text{ Max}, V_{CCQ} = V_{CCQ} \text{ Max}$ using standard word/byte single reads Device is enabled (see Table 2) $f = 5 \text{ MHz}, I_{OUT} = 0 \text{ mA}$
$I_{CCW}$	$V_{CC}$ Program or Set Lock-Bit Current	1,4,5	35	60	mA	CMOS Inputs, $V_{PEN} = V_{CC}$
			40	70	mA	TTL Inputs, $V_{PEN} = V_{CC}$
$I_{CCE}$	$V_{CC}$ Block Erase or Clear Block Lock-Bits Current	1,4,5	35	70	mA	CMOS Inputs, $V_{PEN} = V_{CC}$
			40	80	mA	TTL Inputs, $V_{PEN} = V_{CC}$
$I_{CCWS}$ $I_{CCES}$	$V_{CC}$ Program Suspend or Block Erase Suspend Current	1,4,6		10	mA	Device is disabled (see Table 2)

## DC Characteristics, Continued

Symbol	Parameter	Notes	Min	Max	Unit	Test Conditions
$V_{IL}$	Input Low Voltage	5	-0.5	0.8	V	
$V_{IH}$	Input High Voltage	5	2.0	$V_{CCQ} + 0.5$	V	
$V_{OL}$	Output Low Voltage	2,5		0.4	V	$V_{CCQ} = V_{CCQ2/3}$ Min $I_{OL} = 2$ mA
				0.2	V	$V_{CCQ} = V_{CCQ2/3}$ Min $I_{OL} = 100$ $\mu$ A
$V_{OH}$	Output High Voltage	2,5	$0.85 \times V_{CCQ}$		V	$V_{CCQ} = V_{CCQ}$ Min $I_{OH} = -2.5$ mA
			$V_{CCQ} - 0.2$		V	$V_{CCQ} = V_{CCQ}$ Min $I_{OH} = -100$ $\mu$ A
$V_{PENLK}$	$V_{PEN}$ Lockout during Program, Erase and Lock-Bit Operations	5,7,8		2.0	V	
$V_{PENH}$	$V_{PEN}$ during Block Erase, Program, or Lock-Bit Operations	7,8	2.7	3.6	V	
$V_{LKO}$	$V_{CC}$ Lockout Voltage	9	2.0		V	

**NOTES:**

- All currents are in RMS unless otherwise noted. These currents are valid for all product versions (packages and speeds). Contact Intel's Application Support Hotline or your local sales office for information about typical specifications.
- Includes STS.
- CMOS inputs are either  $V_{CC} \pm 0.2$  V or  $GND \pm 0.2$  V. TTL inputs are either  $V_{IL}$  or  $V_{IH}$ .
- Current values are specified over the temperature range (0 °C to 70 °C) and may increase slightly at -25 °C.
- Sampled, not 100% tested.
- $I_{CCWS}$  and  $I_{CCES}$  are specified with the device de-selected. If the device is read or written while in erase suspend mode, the device's current draw is  $I_{CCR}$  or  $I_{CCW}$ .
- Block erases, programming, and lock-bit configurations are inhibited when  $V_{PEN} \leq V_{PENLK}$ , and not guaranteed in the range between  $V_{PENLK}$  (max) and  $V_{PENH}$  (min), and above  $V_{PENH}$  (max).
- Typically,  $V_{PEN}$  is connected to  $V_{CC}$  (2.7 V–3.6 V).
- Block erases, programming, and lock-bit configurations are inhibited when  $V_{CC} < V_{LKO}$ , and not guaranteed in the range between  $V_{LKO}$  (min) and  $V_{CC}$  (min), and above  $V_{CC}$  (max).

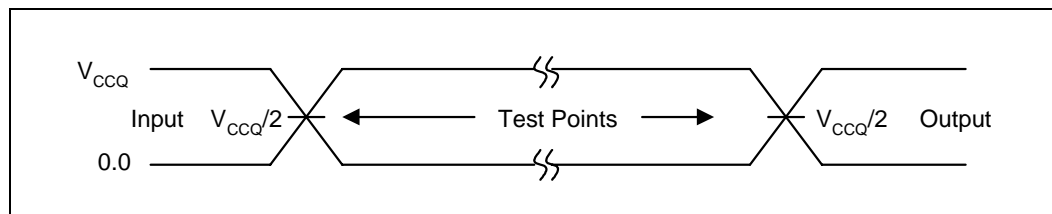
**Figure 15. Transient Input/Output Reference Waveform for  $V_{CCQ} = 3.0$  V–3.6 V or  $V_{CCQ} = 2.7$  V–3.6 V**

**NOTE:** AC test inputs are driven at  $V_{CCQ}$  for a Logic "1" and 0.0 V for a Logic "0." Input timing begins, and output timing ends, at  $V_{CCQ}/2$  V (50% of  $V_{CCQ}$ ). Input rise and fall times (10% to 90%) < 5 ns.

Figure 16. Transient Equivalent Testing Load Circuit

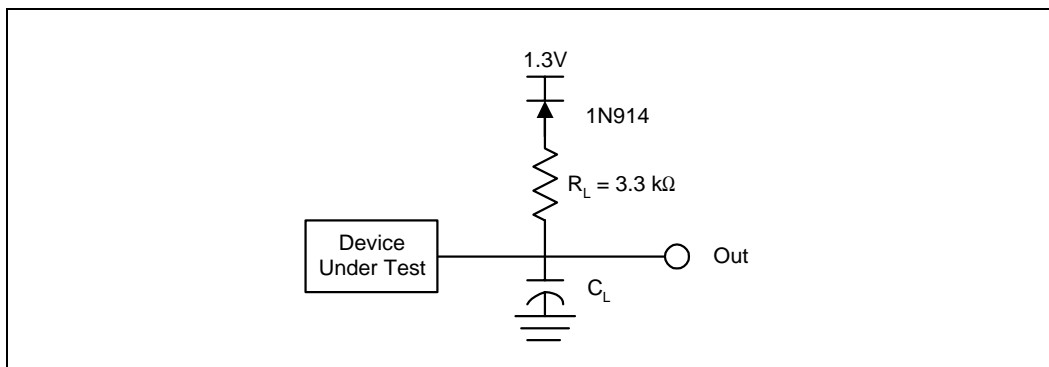

NOTE:  $C_L$  Includes Jig Capacitance

Test Configuration	$C_L$ (pF)
$V_{CCQ} = V_{CC} = 3.0\text{ V} - 3.6\text{ V}$	30
$V_{CCQ} = V_{CC} = 2.7\text{ V} - 3.6\text{ V}$	30

## 6.5 AC Characteristics— Read-Only Operations<sup>(1,2)</sup>

Versions (All units in ns unless otherwise noted)			V <sub>CC</sub>		3.0 V–3.6 V <sup>(3)</sup>		2.7 V–3.6 V <sup>(3)</sup>	
			V <sub>CCQ</sub>		3.0 V–3.6 V <sup>(3)</sup>		2.7 V–3.6 V <sup>(3)</sup>	
#	Sym	Parameter		Notes	Min	Max	Min	Max
R1	t <sub>AVAV</sub>	Read/Write Cycle Time	32 Mbit		110		110	
			64 Mbit		120		120	
			128 Mbit		150		150	
R2	t <sub>AVQV</sub>	Address to Output Delay	32 Mbit			110		110
			64 Mbit			120		120
			128 Mbit			150		150
R3	t <sub>ELQV</sub>	CE <sub>X</sub> to Output Delay	32 Mbit	2		110		110
			64 Mbit	2		120		120
			128 Mbit	2		150		150
R4	t <sub>GLQV</sub>	OE# to Non-Array Output Delay		2, 4		50		50
R5	t <sub>PHQV</sub>	RP# High to Output Delay	32 Mbit			150		150
			64 Mbit			180		180
			128 Mbit			210		210
R6	t <sub>ELQX</sub>	CE <sub>X</sub> to Output in Low Z		5	0		0	
R7	t <sub>GLQX</sub>	OE# to Output in Low Z		5	0		0	
R8	t <sub>EHQZ</sub>	CE <sub>X</sub> High to Output in High Z		5		55		55
R9	t <sub>GHQZ</sub>	OE# High to Output in High Z		5		15		15
R10	t <sub>OH</sub>	Output Hold from Address, CE <sub>X</sub> , or OE# Change, Whichever Occurs First		5	0		0	
R11	t <sub>ELFL</sub> /t <sub>ELFH</sub>	CE <sub>X</sub> Low to BYTE# High or Low		5		10		10
R12	t <sub>FLQV</sub> /t <sub>FHQV</sub>	BYTE# to Output Delay				1000		1000
R13	t <sub>FLQZ</sub>	BYTE# to Output in High Z		5		1000		1000
R14	t <sub>EHEL</sub>	CE <sub>X</sub> High to CE <sub>X</sub> Low		5	0		0	
R15	t <sub>APA</sub>	Page Address Access Time		5, 6		25		30
R16	t <sub>GLQV</sub>	OE# to Array Output Delay		4		25		30

### NOTES:

CE<sub>X</sub> low is defined as the first edge of CE<sub>0</sub>, CE<sub>1</sub>, or CE<sub>2</sub> that enables the device. CE<sub>X</sub> high is defined as the first edge of CE<sub>0</sub>, CE<sub>1</sub>, or CE<sub>2</sub> that disables the device (see Table 2).

- See AC Input/Output Reference Waveforms for the maximum allowable input slew rate.
- OE# may be delayed up to t<sub>ELQV</sub>-t<sub>GLQV</sub> after the first edge of CE<sub>0</sub>, CE<sub>1</sub>, or CE<sub>2</sub> that enables the device (see Table 2) without impact on t<sub>ELQV</sub>.
- See Figures 14–16, Transient Input/Output Reference Waveform for V<sub>CCQ</sub> = 3.0 V –3.6 V or V<sub>CCQ</sub> = 2.7 V –3.6 V, and Transient Equivalent Testing Load Circuit for testing characteristics.
- When reading the flash array a faster t<sub>GLQV</sub> (R16) applies. Non-array reads refer to status register reads, query reads, or device identifier reads.
- Sampled, not 100% tested.
- For devices configured to standard word/byte read mode, R15 (t<sub>APA</sub>) will equal R2 (t<sub>AVQV</sub>).

Figure 17. AC Waveform for Both Page-Mode and Standard Word/Byte Read Operations

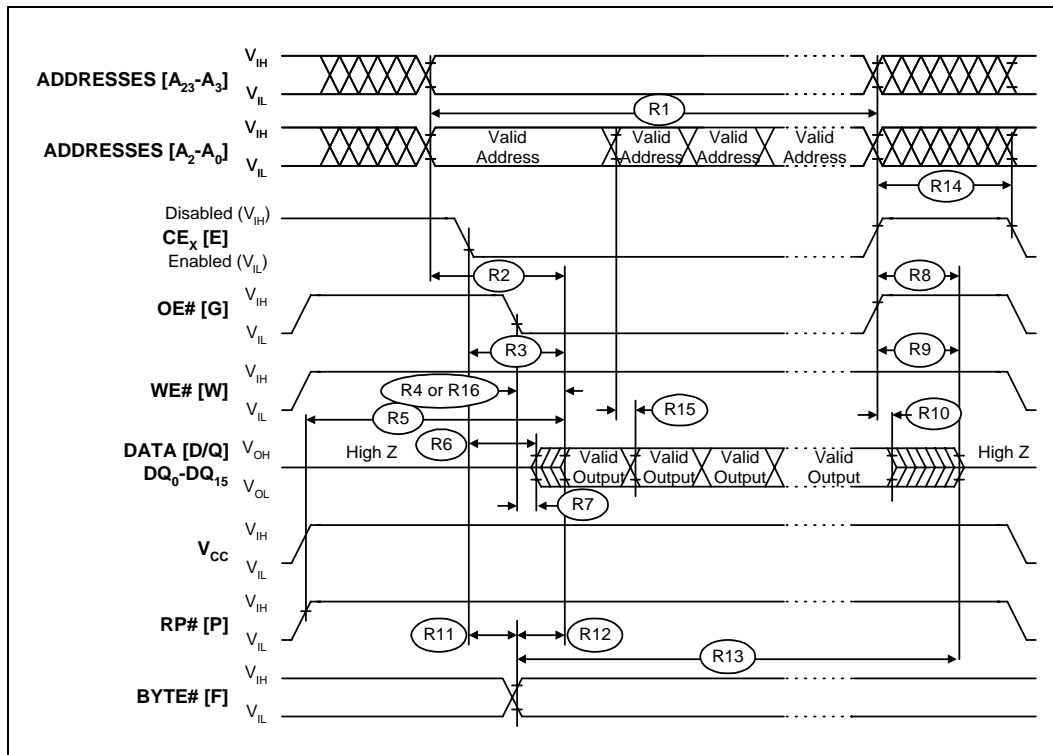

0606\_16

**NOTE:** CE<sub>x</sub> low is defined as the first edge of CE<sub>0</sub>, CE<sub>1</sub>, or CE<sub>2</sub> that enables the device. CE<sub>x</sub> high is defined at the first edge of CE<sub>0</sub>, CE<sub>1</sub>, or CE<sub>2</sub> that disables the device (see Table 2).  
 For standard word/byte read operations, R15 (t<sub>APA</sub>) will equal R2 (t<sub>AVQV</sub>).  
 When reading the flash array a faster t<sub>GLQV</sub> (R16) applies. Non-array reads refer to status register reads, query reads, or device identifier reads.

## 6.6 AC Characteristics— Write Operations<sup>(1,2)</sup>

Versions				Valid for All Speeds		Unit
#	Symbol	Parameter	Notes	Min	Max	
W1	$t_{PHWL}$ ( $t_{PHEL}$ )	RP# High Recovery to WE# ( $CE_X$ ) Going Low	3	1		$\mu$ s
W2	$t_{ELWL}$ ( $t_{WLEL}$ )	$CE_X$ (WE#) Low to WE# ( $CE_X$ ) Going Low	4	0		ns
W3	$t_{WP}$	Write Pulse Width	4	70		ns
W4	$t_{DVWH}$ ( $t_{DVEH}$ )	Data Setup to WE# ( $CE_X$ ) Going High	5	50		ns
W5	$t_{AVWH}$ ( $t_{AVEH}$ )	Address Setup to WE# ( $CE_X$ ) Going High	5	55		ns
W6	$t_{WHEH}$ ( $t_{EHWH}$ )	$CE_X$ (WE#) Hold from WE# ( $CE_X$ ) High		10		ns
W7	$t_{WHDX}$ ( $t_{EHDX}$ )	Data Hold from WE# ( $CE_X$ ) High		0		ns
W8	$t_{WHAX}$ ( $t_{EHAX}$ )	Address Hold from WE# ( $CE_X$ ) High		0		ns
W9	$t_{WPH}$	Write Pulse Width High	6	30		ns
W11	$t_{VPWH}$ ( $t_{VPEH}$ )	$V_{PEN}$ Setup to WE# ( $CE_X$ ) Going High	3	0		ns
W12	$t_{WHGL}$ ( $t_{EHGL}$ )	Write Recovery before Read	7	35		ns
W13	$t_{WHRL}$ ( $t_{EHRL}$ )	WE# ( $CE_X$ ) High to STS Going Low	8		500	ns
W15	$t_{QVVL}$	$V_{PEN}$ Hold from Valid SRD, STS Going High	3,8,9	0		ns

### NOTES:

$CE_X$  low is defined as the first edge of  $CE_0$ ,  $CE_1$ , or  $CE_2$  that enables the device.  $CE_X$  high is defined at the first edge of  $CE_0$ ,  $CE_1$ , or  $CE_2$  that disables the device (see Table 2).

1. Read timing characteristics during block erase, program, and lock-bit configuration operations are the same as during read-only operations. Refer to *AC Characteristics—Read-Only Operations*.
2. A write operation can be initiated and terminated with either  $CE_X$  or WE#.
3. Sampled, not 100% tested.
4. Write pulse width ( $t_{WP}$ ) is defined from  $CE_X$  or WE# going low (whichever goes low first) to  $CE_X$  or WE# going high (whichever goes high first). Hence,  $t_{WP} = t_{WLWH} = t_{ELEH} = t_{WLEH} = t_{ELWH}$ . If  $CE_X$  is driven low 10 ns before WE# going low, WE# pulse width requirement decreases to  $t_{WP} - 10$  ns.
5. Refer to Table 4 for valid  $A_{IN}$  and  $D_{IN}$  for block erase, program, or lock-bit configuration.
6. Write pulse width high ( $t_{WPH}$ ) is defined from  $CE_X$  or WE# going high (whichever goes high first) to  $CE_X$  or WE# going low (whichever goes low first). Hence,  $t_{WPH} = t_{WHWL} = t_{EHHL} = t_{WHEL} = t_{EHWL}$ .
7. For array access,  $t_{AVQV}$  is required in addition to  $t_{WHGL}$  for any accesses after a write.
8. STS timings are based on STS configured in its RY/BY# default mode.
9.  $V_{PEN}$  should be held at  $V_{PENH}$  until determination of block erase, program, or lock-bit configuration success (SR.1/3/4/5 = 0).

## 6.7 Block Erase, Program, and Lock-Bit Configuration Performance<sup>(1,2,3)</sup>

#	Sym	Parameter	Notes	Typ	Max	Unit
W16		Write Buffer Byte Program Time (Time to Program 32 bytes/16 words)	4,5,6,7	218	654	μs
W16	$t_{WHQV3}$ $t_{EHQV3}$	Byte Program Time (Using Word/Byte Program Command)	4	210	630	μs
		Block Program Time (Using Write to Buffer Command)	4	0.8	2.4	sec
W16	$t_{WHQV4}$ $t_{EHQV4}$	Block Erase Time	4	1.0	5.0	sec
W16	$t_{WHQV5}$ $t_{EHQV5}$	Set Lock-Bit Time	4	64	75	μs
W16	$t_{WHQV6}$ $t_{EHQV6}$	Clear Block Lock-Bits Time	4	0.5	0.70	sec
W16	$t_{WHRH1}$ $t_{EHRH1}$	Program Suspend Latency Time to Read		25	75	μs
W16	$t_{WHRH}$ $t_{EHRH}$	Erase Suspend Latency Time to Read		26	35	μs

### NOTES:

1. Typical values measured at  $T_A = +25\text{ }^\circ\text{C}$  and nominal voltages. Assumes corresponding lock-bits are not set. Subject to change based on device characterization.
2. These performance numbers are valid for all speed versions.
3. Sampled but not 100% tested.
4. Excludes system-level overhead.
5. These values are valid when the buffer is full, and the start address is aligned on a 32-byte boundary.
6. Effective per-byte program time ( $t_{WHQV1}$ ,  $t_{EHQV1}$ ) is 6.8 μs/byte (typical)
7. Effective per-word program time ( $t_{WHQV2}$ ,  $t_{EHQV2}$ ) is 13.6 μs/word (typical)
8. Max values are measured at worst case temperature and  $V_{CC}$  corner after 100k cycles

Figure 18. AC Waveform for Write Operations

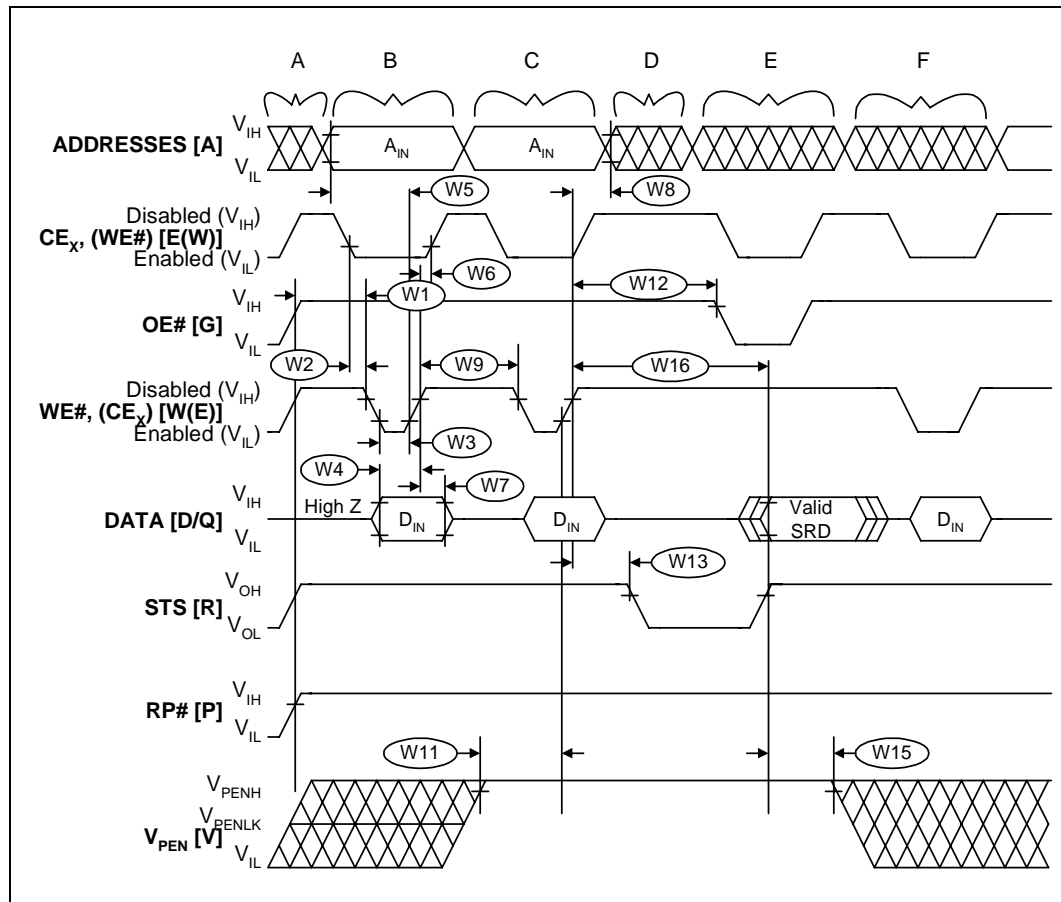

0606\_17

**NOTES:**

$CE_x$  low is defined as the first edge of  $CE_0$ ,  $CE_1$ , or  $CE_2$  that enables the device.  $CE_x$  high is defined at the first edge of  $CE_0$ ,  $CE_1$ , or  $CE_2$  that disables the device (see Table 2).

STS is shown in its default mode (RY/BY#).

- $V_{CC}$  power-up and standby.
- Write block erase, write buffer, or program setup.
- Write block erase or write buffer confirm, or valid address and data.
- Automated erase delay.
- Read status register or query data.
- Write Read Array command.

Figure 19. AC Waveform for Reset Operation

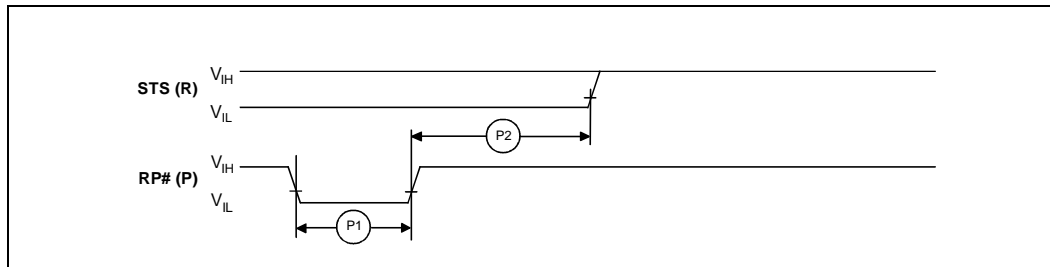

0606\_18

NOTE: STS is shown in its default mode (RY/BY#).

Reset Specifications<sup>(1)</sup>

#	Sym	Parameter	Notes	Min	Max	Unit
P1	t <sub>PLPH</sub>	RP# Pulse Low Time (If RP# is tied to V <sub>CC</sub> , this specification is not applicable)	2	35		μs
P2	t <sub>PHRH</sub>	RP# High to Reset during Block Erase, Program, or Lock-Bit Configuration	3		100	ns

NOTES:

1. These specifications are valid for all product versions (packages and speeds).
2. If RP# is asserted while a block erase, program, or lock-bit configuration operation is not executing then the minimum required RP# Pulse Low Time is 100 ns.
3. A reset time, t<sub>PHQV</sub>, is required from the latter of STS (in RY/BY# mode) or RP# going high until outputs are valid.

## 7.0 Ordering Information

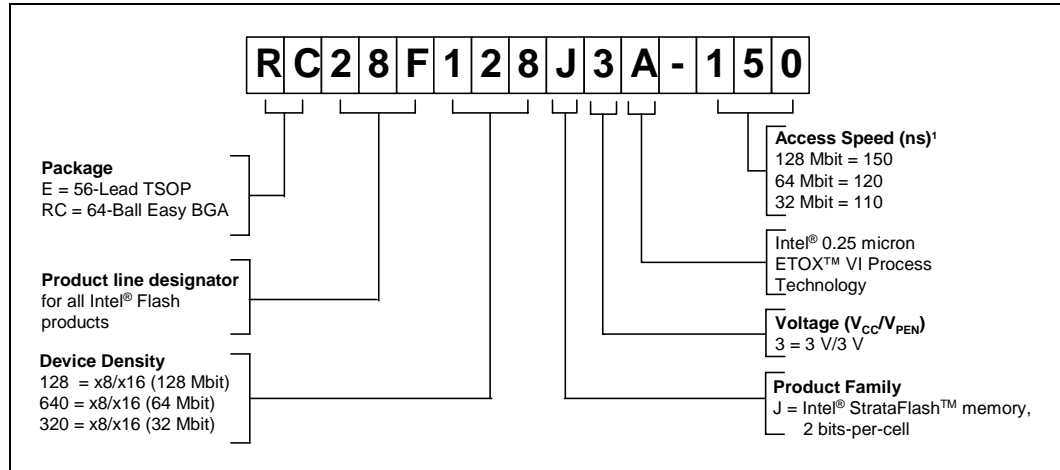

**NOTE:**

1. These speeds are for either the standard asynchronous read access times or for the first access of a page-mode read sequence.

**VALID COMBINATIONS**

56-Lead TSOP	64-Ball Easy BGA
E28F128J3A-150	RC28F128J3A-150
E28F640J3A-120	RC28F640J3A-120
E28F320J3A-110	RC28F320J3A-110

## 8.0 Additional Information

Order Number	Document/Tool
298130	3 Volt Intel® StrataFlash™ Memory 28F128J3A, 28F640J3A, 320J3A Specification Update
290668	Intel® Persistent Storage Manager datasheet
292237	AP-689 Using Intel® Persistent Storage Manager
Note 3	AP-707 3 Volt Intel® StrataFlash™ Memory CPU Interface Design Guide
290606	5 Volt Intel® StrataFlash™ Memory 28F320J5 and 28F640J5 datasheet
290608	3 Volt FlashFile™ Memory; 28F160S3 and 28F320S3 datasheet
290609	5 Volt FlashFile™ Memory; 28F160S5 and 28F320S5 datasheet
290429	5 Volt FlashFile™ Memory; 28F008SA datasheet
290598	3 Volt FlashFile™ Memory; 28F004S3, 28F008S3, 28F016S3 datasheet
290597	5 Volt FlashFile™ Memory; 28F004S5, 28F008S5, 28F016S5 datasheet
297859	AP-677 Intel® StrataFlash™ Memory Technology
292222	AP-664 Designing Intel® StrataFlash™ Memory into Intel® Architecture
292221	AP-663 Using the Intel® StrataFlash™ Memory Write Buffer
292218	AP-660 Migration Guide to 3 Volt Intel® StrataFlash™ Memory
292205	AP-647 5 Volt Intel® StrataFlash™ Memory Design Guide
292204	AP-646 Common Flash Interface (CFI) and Command Sets
292202	AP-644 Migration Guide to 5 Volt Intel® StrataFlash™ Memory
298161	Intel® Flash Memory Chip Scale Package User's Guide
Note 4	Preliminary Mechanical Specification for Easy BGA Package

**NOTE:**

1. Please call the Intel Literature Center at (800) 548-4725 to request Intel documentation. International customers should contact their local Intel or distribution sales office.
2. Visit Intel's World Wide Web home page at <http://www.intel.com> for technical documentation and tools.
3. For the most current information on Intel StrataFlash memory, visit our website at <http://developer.intel.com/design/flash/isf>.
4. This document is available on the web at <http://developer.intel.com/design/flcomp/packdata/298049.htm>.

This datasheet has been downloaded from:

[www.DatasheetCatalog.com](http://www.DatasheetCatalog.com)

Datasheets for electronic components.



LittleDiode supplies new, hard to find or obsolete electronic components and semiconductors all over the world.

With over two million different components listed you are sure to find the part you need.

Feel free to visit us today at our online store:

[LittleDiode.com](http://LittleDiode.com)

Looking forward to providing you with the best possible service.