

## Ultrafast Plastic Rectifier

Reverse Voltage 400 to 600V

Forward Current 4.0A

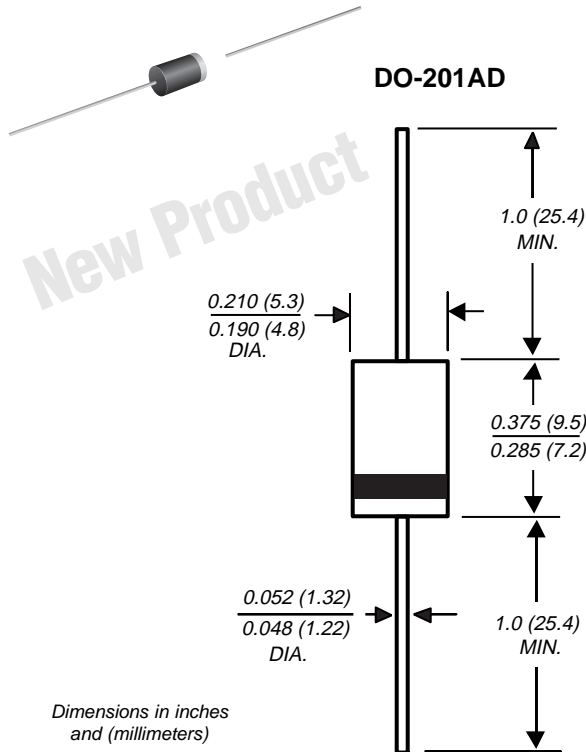

### Features

- Plastic package has Underwriters Laboratories Flammability Classification 94V-0
- Ideally suited for use in very high frequency switching power supplies, inverters and as free wheeling diodes
- Ultrafast recovery time for high efficiency
- Excellent high temperature switching
- Glass passivated junction
- High temperature soldering guaranteed: 250°C/10 seconds, 0.375" (9.5mm) lead length, 5 lbs. (2.3kg) tension

### Mechanical Data

**Case:** JEDEC DO-201AD molded plastic body over passivated chip

**Terminals:** Plated axial leads, solderable per MIL-STD-750, Method 2026

**Polarity:** Color band denotes cathode end

**Mounting Position:** Any

**Weight:** 0.045 ounce, 1.2 grams

## Maximum Ratings & Thermal Characteristics

Ratings at 25°C ambient temperature unless otherwise specified.

	Symbols	MUR440	MUR460	Units
Maximum repetitive peak reverse voltage	$V_{RRM}$	400	600	V
Working peak reverse voltage	$V_{RWM}$	400	600	V
Maximum DC blocking voltage	$V_{DC}$	400	600	V
Maximum average forward rectified current at $T_A = 40^\circ\text{C}$ See figure 1	$I_{F(AV)}$	4.0		A
Peak forward surge current 8.3 ms single half sine-wave superimposed on rated load (JEDEC Method)	$I_{FSM}$	125		A
Typical thermal resistance junction to ambient (NOTE 2)	$R_{\theta JA}$	28		$^\circ\text{C}/\text{W}$
Operating junction and storage temperature range	$T_J, T_{STG}$	-65 to +175°C		$^\circ\text{C}$

## Electrical Characteristics

Ratings at 25°C ambient temperature unless otherwise specified.

	Symbols	MUR440	MUR460	Units
Maximum instantaneous forward voltage (NOTE 1) at 3.0A, $T_J=150^\circ\text{C}$ at 3.0A, $T_J=25^\circ\text{C}$ at 4.0A, $T_J=25^\circ\text{C}$	$V_F$	1.05 1.25 1.28		V
Maximum instantaneous reverse current at rated DC blocking voltage (NOTE 1) $T_J=25^\circ\text{C}$ $T_J=150^\circ\text{C}$	$I_R$	10 250		$\mu\text{A}$
Maximum reverse recovery time at $I_F=0.5\text{A}$ , $I_R=1.0\text{A}$ , $I_{rr}=0.25\text{A}$	$t_{rr}$	50		ns
Maximum reverse recovery time at, $I_F=1.0\text{A}$ , $di/dt=50\text{A}/\mu\text{s}$ , $V_R=30\text{V}$ , $I_{rr}=10\% I_{RM}$	$t_{rr}$	75		ns
Maximum forward recovery time ( $I_F=1.0\text{A}$ , $di/dt=100\text{A}/\mu\text{s}$ , Rec. to 1.0V)	$t_{fr}$	50		ns

### NOTES:

(1) Pulse test:  $t_p=300\mu\text{s}$ , duty cycle  $\leq 2\%$

(2) Lead length = 1/2" on P.C. board with 1.5" x 1.5" copper surface

## Ratings & Characteristic Curves

**Figure 1 – Forward Current Derating Curve**

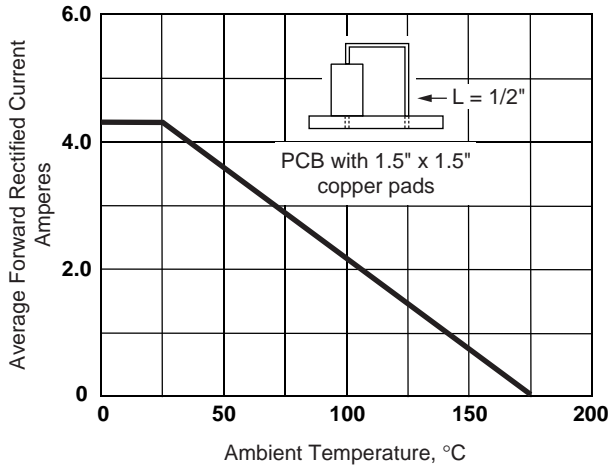

**Figure 2 – Maximum Non-Repetitive Peak Forward Surge Current**

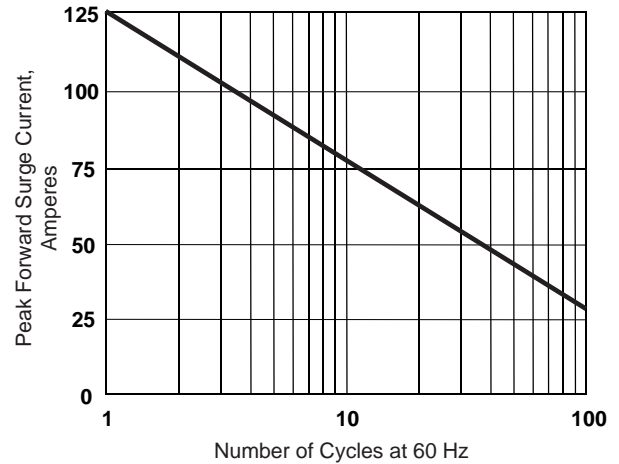

**Figure 3 – MUR460 Typical Instantaneous Forward Characteristics**

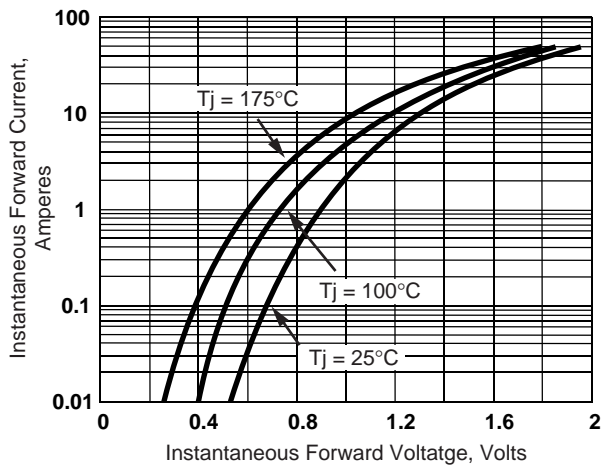

**Figure 4 – MUR460 Typical Reverse Characteristics**

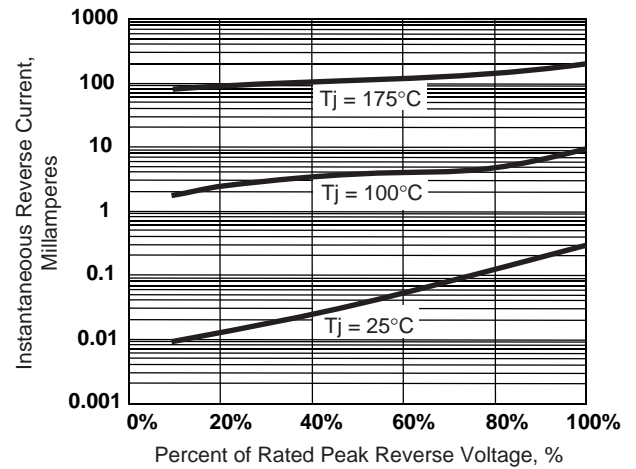

**Figure 5 – Typical Junction Capacitance per Leg**

