

MBR15xxCT, MBRF15xxCT & MBRB15xxCT Series

Dual Schottky Barrier Rectifier

Reverse Voltage 35 to 60 V
Forward Current 15 A

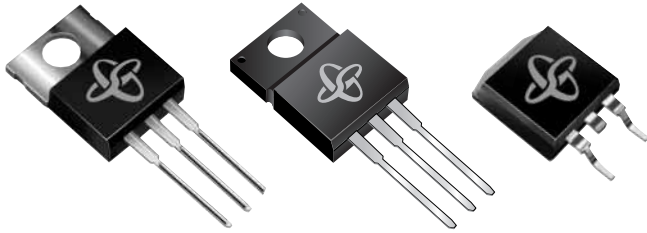

TO-220AB (MBR15xxCT)

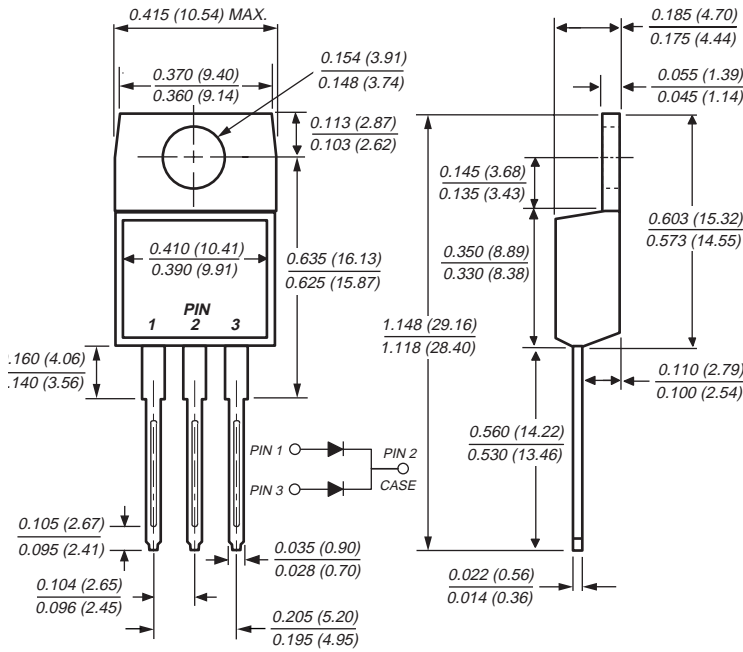

Mounting Pad Layout TO-263AB

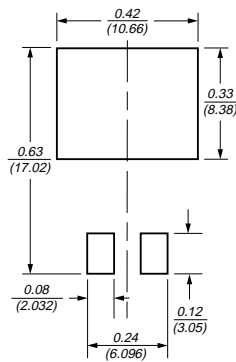

Dimensions in inches and (millimeters)

Features

- Plastic package has Underwriters Laboratory Flammability Classification 94V-0
- Dual rectifier construction, positive center tap
- Metal silicon junction, majority carrier conduction
- Low power loss, high efficiency
- Guardring for overvoltage protection
- For use in low voltage, high frequency inverters, free wheeling, and polarity protection applications
- High temperature soldering guaranteed: 250°C/10 seconds, 0.25" (6.35mm) from case

ITO-220AB (MBRF15xxCT)

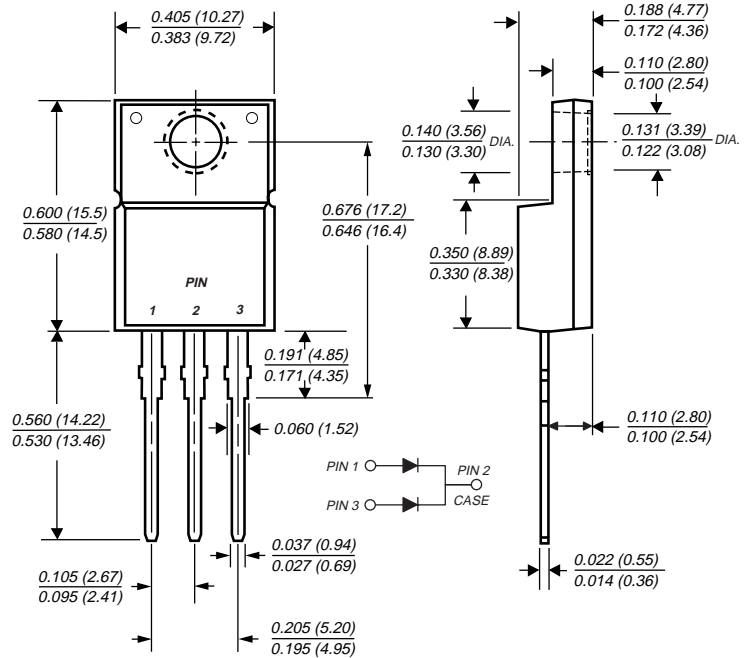

TO-263AB (MBRB15xxCT)

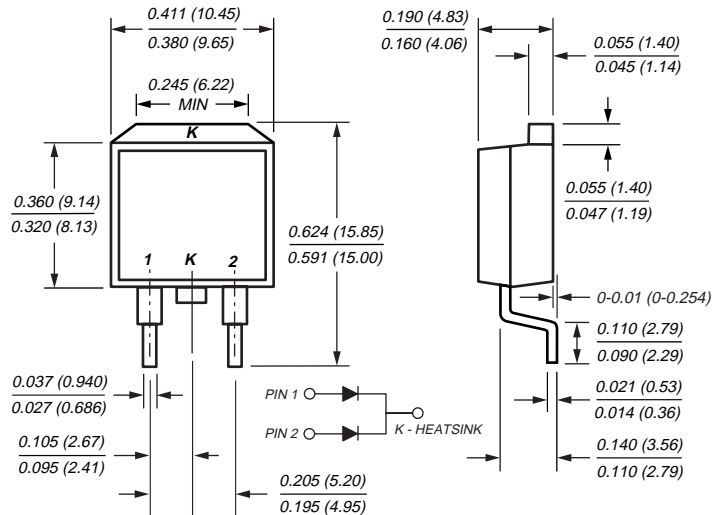

Mechanical Data

Case: JEDEC TO-220AB, ITO-220AB & TO-263AB molded plastic body

Terminals: Plated leads, solderable per MIL-STD-750, Method 2026

Polarity: As marked

Mounting Position: Any

Mounting Torque: 10 in-lbs maximum

Weight: 0.08 ounce, 2.24 grams

MBR15xxCT, MBRF15xxCT & MBRB15xxCT Series

Dual Schottky Barrier Rectifier

Maximum Ratings (T_C = 25°C unless otherwise noted)

Parameter	Symbol	MBR1535CT	MBR1545CT	MBR1550CT	MBR1560CT	Unit
Maximum repetitive peak reverse voltage	V _{RRM}	35	45	50	60	V
Working peak reverse voltage	V _{RWM}	35	45	50	60	V
Maximum DC blocking voltage	V _{DC}	35	45	50	60	V
Maximum average forward rectified current <i>Total device at TC = 105°C Per leg</i>	I _{F(AV)}	15 7.5				A
Peak repetitive forward current at T _C = 105°C per leg (rated V _R , 20 KHz sq. wave)	I _{FRM}	15				A
Peak forward surge current 8.3ms single half sine-wave superimposed on rated load (JEDEC Method)	I _{FSM}	150				A
Peak repetitive reverse surge current per leg at t _p = 2.0μs, 1KHz	I _{RRM}	1.0		0.5		A
Voltage rate of change (rated V _R)	dv/dt	10,000				V/μs
Operating junction temperature range	T _J	-65 to +150				°C
Storage temperature range	T _{STG}	-65 to +175				°C
RMS Isolation voltage (MBRF type only) from terminals to heatsink with t = 1.0 second, RH ≤ 30%	V _{ISOL}	4500 (NOTE 1) 3500 (NOTE 2) 1500 (NOTE 3)				V

Electrical Characteristics (T_C = 25°C unless otherwise noted)

Parameter	Symbol	MBR1535CT	MBR1545CT	MBR1550CT	MBR1560CT	Unit
Maximum instantaneous forward voltage per leg (Note 4) at I _F = 7.5A, T _C = 25°C at I _F = 7.5A, T _C = 125°C at I _F = 15A, T _C = 25°C at I _F = 15A, T _C = 125°C	V _F	– 0.57 0.84 0.72		0.75 0.65 – –		V
Maximum instantaneous reverse current at rated DC blocking voltage per leg (Note 4)	I _R	0.1 15		1.0 50		mA

Thermal Characteristics (T_C = 25°C unless otherwise noted)

Parameter	Symbol	MBR	MBRF	MBRB	Unit
Maximum thermal resistance per leg	R _{θJA} R _{θJC}	60 3.0	– 5.0	60 3.0	°C/W

Notes:

- (1) Clip mounting (on case), where lead does not overlap heatsink with 0.110" offset
- (2) Clip mounting (on case), where leads do overlap heatsink
- (3) Screw mounting with 4-40 screw, where washer diameter is ≤ 4.9 mm (0.19")
- (4) Pulse test: 300μs pulse width, 1% duty cycle

Ordering Information

Product	Case	Package Code	Package Option
MBR1535CT - MBR1560CT	TO-220AB	45	Anti-Static tube, 50/tube, 2K/carton
MBRF1535CT - MBRF1560CT	ITO-220AB	45	Anti-Static tube, 50/tube, 2K/carton
MBRB1535CT - MBRB1560CT	TO-263AB	31	13" reel, 800/reel, 4.8K/carton
		45	Anti-Static tube, 50/tube, 2K/carton
		81	Anti-Static 13" reel, 800/reel, 4.8K/carton

MBR15xxCT, MBRF15xxCT & MBRB15xxCT Series

Ratings and Characteristic Curves ($T_A = 25^\circ\text{C}$ unless otherwise noted)

