

**Features**

- Drives 360mA at 16V<sub>P-P</sub> on ±12V supplies
- 40V<sub>P-P</sub> differential output drive into 100Ω
- -75dBc typical driver output distortion driving 50Ω at 1MHz and ½-I<sub>S</sub> bias current
- Low quiescent current of 3.5mA per amplifier in ½-I<sub>S</sub> mode
- Power down disable mode

**Applications**

- ADSL G.DMT and G.lite CO line driving
- G.SHDSL, HDSL2 line driver
- ADSL CPE line driving
- Video distribution amplifier
- Video twisted-pair line driver

**Ordering Information**

Part No	Package	Tape & Reel	Outline #
EL1507CS	16-Pin SO		MDP0027
EL1507CL	16-Pin LPP		MDP0046

**General Description**

The EL1507C is a very low power dual operational amplifier designed for central office and customer premise line driving for DMT ADSL solutions. This device features a high drive capability of 400mA while consuming only 7.5mA of supply current per amplifier from ±12V supplies. This driver achieves a typical distortion of less than -75dBc, at 1MHz into a 50Ω load. The EL1507C is available in the thermally-enhanced 16-pin SO package, as well as a 16-pin LPP package. Both are specified for operation over the full -40°C to +85°C temperature range.

The EL1507C has two control pins, C0 and C1. With the selection of C0 and C1, the device can be set into full-I<sub>S</sub> power, ¾-I<sub>S</sub> power, ½-I<sub>S</sub> power, and power down disable modes. The EL1507C maintains excellent distortion and load driving capabilities even in the lowest power settings.

**Connection Diagram**

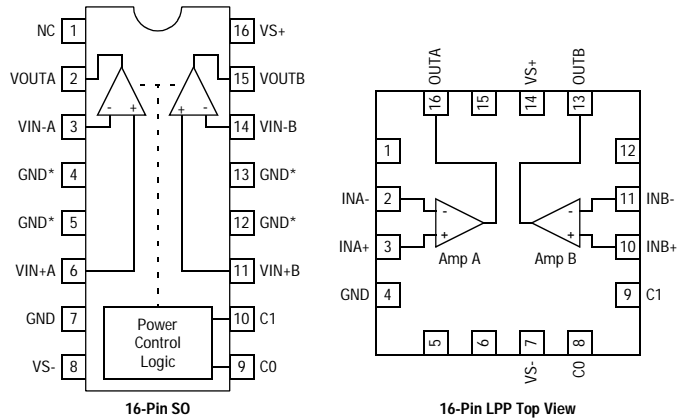

\* These GND pins are heat spreaders

Note: All information contained in this data sheet has been carefully checked and is believed to be accurate as of the date of publication; however, this data sheet cannot be a "controlled document". Current revisions, if any, to these specifications are maintained at the factory and are available upon your request. We recommend checking the revision level before finalization of your design documentation.

# ***EL1507C - Product Brief***

*Medium Power Differential Line Driver*

## **General Disclaimer**

Specifications contained in this data sheet are in effect as of the publication date shown. Elantec, Inc. reserves the right to make changes in the circuitry or specifications contained herein at any time without notice. Elantec, Inc. assumes no responsibility for the use of any circuits described herein and makes no representations that they are free from patent infringement.

***élantec***

HIGH PERFORMANCE ANALOG INTEGRATED CIRCUITS

## **Elantec Semiconductor, Inc.**

675 Trade Zone Blvd.

Milpitas, CA 95035

Telephone: (408) 945-1323

(888) ELANTEC

Fax: (408) 945-9305

European Office: +44-118-977-6020

Japan Technical Center: +81-45-682-5820

## **WARNING - Life Support Policy**

Elantec, Inc. products are not authorized for and should not be used within Life Support Systems without the specific written consent of Elantec, Inc. Life Support systems are equipment intended to support or sustain life and whose failure to perform when properly used in accordance with instructions provided can be reasonably expected to result in significant personal injury or death. Users contemplating application of Elantec, Inc. Products in Life Support Systems are requested to contact Elantec, Inc. factory headquarters to establish suitable terms & conditions for these applications. Elantec, Inc.'s warranty is limited to replacement of defective components and does not cover injury to persons or property or other consequential damages.



LittleDiode supplies new, hard to find or obsolete electronic components and semiconductors all over the world.

With over two million different components listed you are sure to find the part you need.

Feel free to visit us today at our online store:

[LittleDiode.com](http://LittleDiode.com)

Looking forward to providing you with the best possible service.