

MAXIM

High Accuracy Fast Buffer

MAX460

General Description

The MAX460 is a high speed, JFET input voltage follower similar and pin compatible to the LH0033, but with input specifications significantly improved over the older device. This device is a direct pin-for-pin replacement for the EL2005. The cascode input stage maintains a constant high input resistance over the full $\pm 10V$ input voltage range. The input loading can be characterized as a $1000G\Omega$ resistance in parallel with a $3pF$ capacitor to ground. In most practical applications this can be considered a negligible load.

Applications

- Fast Sample/Hold Amplifiers
- High Source Impedance Accurate Buffering
- Flash A/D Input Buffering
- Video Distribution
- CRT Drive
- Coaxial Line Driver

Features

- ◆ Pin for Pin Second Source!
- ◆ Pin Compatible with LH0033 and EL2005
- ◆ Low Input Current 50pA
- ◆ Low Offset Voltage 2mV
- ◆ Low Offset Drift $25\mu V/^\circ C$
- ◆ High Slew Rate 1500V/ μs
- ◆ Fast Rise & Fall Times 2.5ns
- ◆ High Input Resistance 1000G Ω
- ◆ Wide Bandwidth 140MHz

Ordering Information

PART	TEMP. RANGE	PACKAGE
MAX460MGC	-55°C to +125°C	12 Lead TO-8
MAX460IGC	-25°C to +85°C	12 Lead TO-8
EL2005G	-55°C to +125°C	12 Lead TO-8
EL2005CG	-25°C to +85°C	12 Lead TO-8

(Note: The EL2005G is equivalent to the MAX460MGC, and the EL2005CG is equivalent to the MAX460IGC.)

Typical Operating Circuit

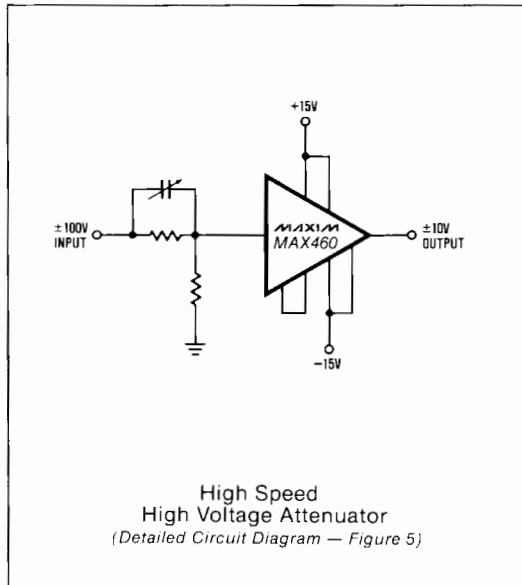

Pin Configuration

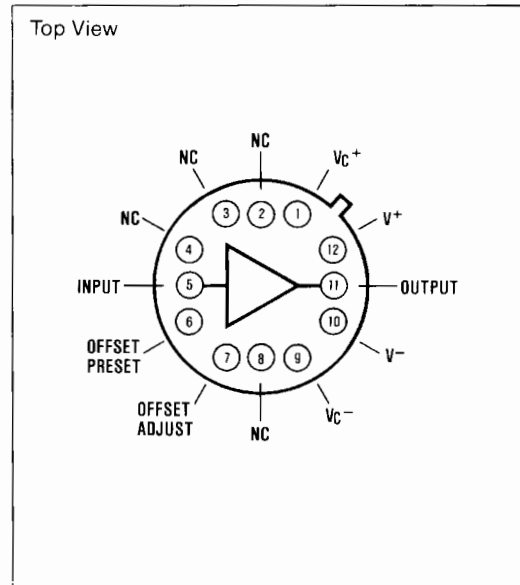

MAXIM

Maxim Integrated Products 1

MAXIM is a registered trademark of Maxim Integrated Products.

High Accuracy Fast Buffer

ABSOLUTE MAXIMUM RATINGS

Supply Voltage ($V^+ - V^-$)	40V	Peak Output Current	±250mA
Maximum Power Dissipation	1.5W (See Graph)	Operating Temperature Range	
Maximum Junction Temperature	+175°C	MAX460MGC	-55°C to +125°C
Input Voltage Range	± V_S	MAX460IGC	-25°C to +85°C
Continuous Output Current	±100mA	Storage Temperature Range	-65°C to +150°C
		Lead Temperature (Soldering, 10 sec.)	+300°C

Stresses above those listed under "Absolute Maximum Ratings" may cause permanent damage to the device. These are stress ratings only and functional operation of the device at these or any other conditions above those indicated in the operational sections of the specifications is not implied. Exposure to absolute maximum rating conditions for extended periods may affect device reliability.

ELECTRICAL CHARACTERISTICS ($V_S = \pm 15V$, $V_{IN} = 0V$, $T_{MIN} \leq T_A \leq T_{MAX}$) (Note 1)

PARAMETER	SYMBOL	CONDITIONS	MAX460MGC			MAX460IGC			UNITS
			MIN	TYP	MAX	MIN	TYP	MAX	
Output Offset Voltage	V_{OS}	$R_S = 100\Omega$, $T_J = +25^\circ C$		2	5		3	10	mV
		$R_S = 100\Omega$			10			15	
Offset Tempco	$\Delta V_{OS}/\Delta T$	$R_S = 100\Omega$ (Note 3)		25			25		$\mu V/^\circ C$
Supply Rejection	PSRR	$+10V < V_S < \pm 20V$	66	75		60	75		dB
Input bias current	I_B	$T_J = +25^\circ C$ (Notes 2 and 7)		2	50		5	100	pA
		$T_A = +25^\circ C$, (Notes 4 and 7)		50	500		100	1000	
		$T_J = T_A = T_{MAX}$		2	5		0.5	5	nA
Voltage Gain	A_V	$R_L = 1k\Omega$	0.97	0.98	1	0.96	0.98	1	V/V
		$R_L = 100\Omega$	0.92	0.95	0.98	0.91	0.95	0.99	
Input Impedance	R_{IN}	-10V to +10V	2	1000		2	1000		G Ω
		$T_J = +25^\circ C$	10	1000		10	1000		
Output Resistance	R_{OUT}	$V_{IN} = \pm 1V$		4	8		4	8	Ω
Output Voltage Swing	V_{OUT}	$V_{IN} = \pm 14V$, $R_L = 1k\Omega$	12	12.5		12	12.5		V
		$V_{IN} = \pm 10.5V$, $R_L = 100\Omega$, $T_A = +25^\circ C$	9	9.8		9	9.8		
External Offset Resistance	R_{EXT}	$V_{OS} = 0mV$, $T_A = +25^\circ C$ (Note 6)	0	75	200	0	75	200	Ω
Supply Current	I_S	$V_{IN} = 0V$ (Note 5)		19	22		19	24	mA
Power Consumption	P_S	$V_{IN} = 0V$		570	660		570	720	mW

AC ELECTRICAL CHARACTERISTICS ($T_C = +25^\circ C$, $V_S = \pm 15V$, $R_S = 50\Omega$, $R_L = 1k\Omega$)

PARAMETER	SYMBOL	CONDITIONS	MAX460MGC			MAX460IGC			UNIT
			MIN	TYP	MAX	MIN	TYP	MAX	
Slew Rate	SR	$V_{IN} = \pm 10V$, $V_{OUT} = \pm 5V$	1000	1500		1000	1500		V/ μs
Bandwidth	BW	$V_{IN} = 1V_{RMS}$		140			140		MHz
Phase Non-Linearity		BW = 1 to 20MHz		2			2		deg.
Rise Time	t_r	$\Delta V_{IN} = 0.5V$		2.5			2.5		ns
Fall Time	t_f	$\Delta V_{IN} = 0.5V$		1			1		ns
Distortion	HD	F = 1kHz		< 0.1			< 0.1		%
Voltage Gain	A_V	$R_S = 100\Omega$, $V_{IN} = 1V_{RMS}$, F = 1kHz	0.97	0.99	1	0.96	0.99	1	V/V
Output Resistance	R_{OUT}	$V_{IN} = 1V_{RMS}$, F = 1kHz		4	8		4	8	Ω

Note 1: The MAX460MGC is 100% tested at +25°C, +125°C and -55°C. The MAX460IGC is 100% production tested at +25°C only. Specifications at temperature extremes are verified by sample testing to 10% LTPD, but these limits are not used to calculate outgoing quality level.

Note 2: Specification is at +25°C junction temperature due to requirements of high speed automatic testing.

Note 3: Temperature coefficient measured from +25°C to T_{MAX} .

Note 4: Measured in still air 7 minutes after application of power. Guaranteed through correlated automatic pulse testing.

Note 5: Guaranteed through correlated automatic pulse testing at $T_J = +25^\circ C$.

Note 6: Offset adjust resistor connects between device pin 7 and V^- .

Note 7: Input bias current is guaranteed for $-10V \leq V_{IN} \leq +10V$.

High Accuracy Fast Buffer

MAX460

Circuit Description

The MAX460 combines a cascode JFET input stage with a high current bipolar output stage to form an analog buffer amplifier with very high input impedance and very low output resistance over a wide range of conditions.

In normal operation, the source of Q1 will be offset from the input voltage by the V_{gs} of Q1. The output is offset from the Q1 source voltage by the IR drop across R1 and the V_{be} of Q5. The total of these offsets has been actively trimmed during the assembly process to be nearly zero.

Q8 sets the drain to source voltage of Q1 to a low voltage that is virtually independent of input voltage, so that the input bias current only changes slightly when the input voltage is changed. (This is the primary difference between the MAX460 and the LH0033.)

Q4, Q7 and Q9 are devices similar to Q1, Q5 and Q8. The current forced by the drain of Q9 will have the proper temperature coefficient to balance the temperature coefficient of the main amplifier stage, Q1.

Diode connected transistors Q2 and Q3 provide a two V_{be} voltage difference between the bases of the two output transistors, setting the quiescent current through Q5 and Q6. Resistors R3 and R4 provide a small amount of degeneration to stabilize the quiescent current over temperature.

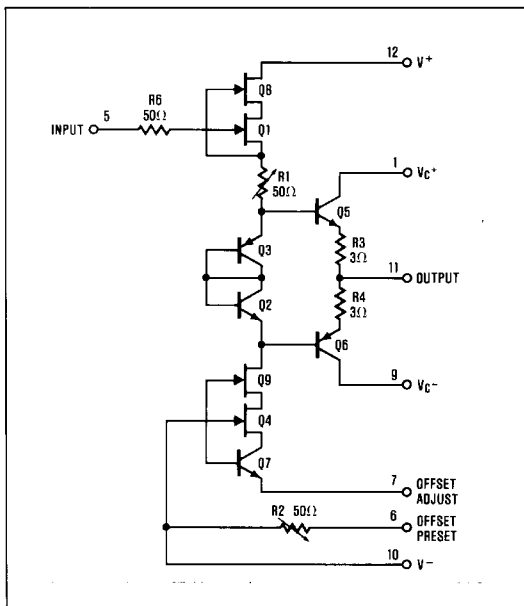

Figure 1.

Applications

Layout Precautions

The MAX460 should be treated as a high frequency amplifier when designing a printed circuit layout. Power supply bypassing to a ground plane with low inductance capacitors should be within a half inch of the device. For applications where the input capacitance is critical, connect the case of the device to the output so that the case capacitance is bootstrapped. For most applications, the case may be left unconnected or grounded. There is no internal connection to the case.

In addition to the high frequency concerns, one must consider the effects of any possible leakage paths if the full input resistance of the MAX460 is to be utilized. Ordinary printed circuit board materials may need a coating to prevent board leakage at high humidities or when dirty. The input in some situations may not even go to the printed circuit board, but instead be connected directly to a sensor or input connector. Lastly, consider the possibility of a guard structure surrounding the input node connected to the MAX460 output: since there will be little or no voltage differential between the input and output, there can be little input current flow even if there is some parasitic leakage resistance.

Offset Voltage Adjustment

For most normal applications of the MAX460, connect pin 6 to pin 7 and use the internally adjusted and guaranteed offset adjustment. When this is not acceptable, or there is a system offset to be absorbed, an external 200 ohm trim pot may be connected from pin 7 to V^- .

Power Dissipation Considerations

The MAX460 package is rated for 0.5W in still air at 125°C and 0.75W with an infinite heat sink. Since the quiescent power is in the neighborhood of 600mW, a heat sink is needed for most 125°C applications and some heavy load applications at lower temperatures. Note that several degrees rise in device temperature can have an adverse effect on the input current and resistance. Several suitable commercial heat sinks are available including the Thermalloy 2241, the Wakefield 215CB and the IERC UP-TO8-48CB. Please note that the can diameter is 0.55 inches nominal as opposed to the JEDEC TO-8 can which is 0.45 inches nominal. (See the outline drawing for detailed dimensions.)

High Accuracy Fast Buffer

Operation from Single or Asymmetrical Power Supplies

Since the MAX460 has no ground pin, an asymmetrical power supply is indistinguishable from a symmetrical supply with a DC level on the input. The single supply case is simply the asymmetrical case taken to the extreme of one of the supplies being zero. In either case, an offset error will be generated corresponding directly to the gain of the circuit times the apparent DC level with respect to a pseudo ground point halfway between the supplies.

$$\text{Output Offset} = 0.5(1 - \text{gain})(|V^+| - |V^-|)$$

For example, a device operating on supplies of +5V and -12V would have an apparent offset error due to the gain of about -35mV. This could easily be corrected with an offset adjust pot connected from pin 7 to V^- as discussed in the offset voltage adjustment section.

Capacitive Loading

The MAX460 is designed to drive heavy capacitive loads without susceptibility to oscillation. Note that the absolute maximum current rating must still be observed, thus the output slew rate times the load capacitance must be less than 250mA. For example, a 1000V/ μ s slew rate with a 250pF load would fall just within the absolute maximum peak current specification. If a heavier capacitive load needs to be driven, the slew rate must be externally limited. Power dissipation resulting from capacitive load currents must be considered independently. The real power dissipated in a circuit driving a sine wave into a pure capacitive load is:

$$P_{ac} = (V_{p-p})^2 \times \text{Frequency} \times C_1$$

This dissipation adds directly to the device's quiescent power and any DC load power that might be present. The sum of all these terms must be less than

the absolute maximum power rating at the temperature of operation. For example, a 250pF load driven to 20V peak to peak at 1MHz adds a reactive power dissipation in the MAX460 of:

$$(20)^2 \times 10^6 \times 250 \times 10^{-12} = 100\text{mW.}$$

This additional power is not often a severe application problem with the MAX460.

Short Circuit Protection

The MAX460 is not internally short circuit protected as most of the possibilities involve some compromise in output swing or transient response. The output stage collectors are available separately, so there are several options open to the user. The simplest and most commonly used is the simple resistor in each output stage collector. For worst case protection these resistors may be calculated by:

$$R_{LIM} = V^+/100\text{mA} = V^-/100\text{mA} = 150\Omega \text{ for } 15\text{V supplies}$$

Unfortunately, a resistor this large severely restricts the voltage swing into a heavy load and the slew rate into a capacitive load. Decoupling the V_C^+ and V_C^- pins with capacitors will retain full output swing for transient pulses, but if the capacitors are made too large (to hold up long pulses) the protection is lost. A better but more complex circuit is shown in figure 4. Here, each output stage collector is driven by a current source set to a safe current, in this case, about 70mA. Ordinarily, the actual output current demand is less than that, so the current source saturates, applies $+V_s$ and $-V_s$ to the output collectors and the MAX460 behaves normally. In the event of a short on the output, however, the current source comes into play and reduces the output stage collector voltage as required to keep the current to a safe level. The output stage collectors may be bypassed with a small capacitor to give additional current capacity for short periods, as would be required in driving a capacitive load.

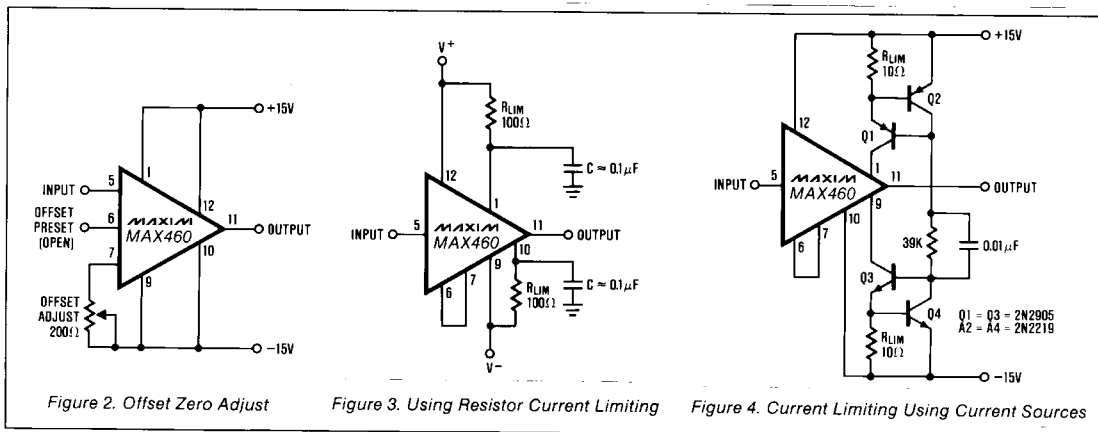

High Accuracy Fast Buffer

MAX460

Typical Applications

High Resistance Compensated Divider to Monitor $\pm 100V$

The circuit in Figure 5 is intended to interface an A/D converter with a maximum input voltage of $\pm 10V$ to an input signal of $\pm 100V$ with a minimum of loading on the signal. Resistors R1 and R2 and capacitor C1 form a frequency compensated 10:1 voltage divider so that the buffer never sees more than its rated $\pm 10V$. For optimum transient response, C1 should be adjusted to compensate for variations in stray capacitance.

Note that this circuit will work with the LH0033 device, but there will be a tendency for the negative gain to be in error due to the rise in the input current for negative input voltages. (See the curve of input bias current vs. input voltage on the LH0033 data sheet.) This non-linearity at the input can cause apparent offset voltage changes in response to an AC signal that would cause the input current to be higher at some parts of the cycle than at others.

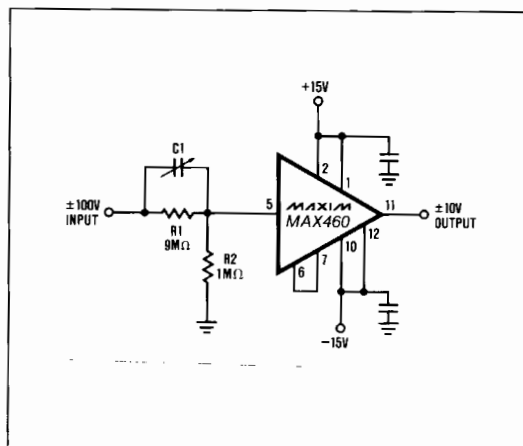
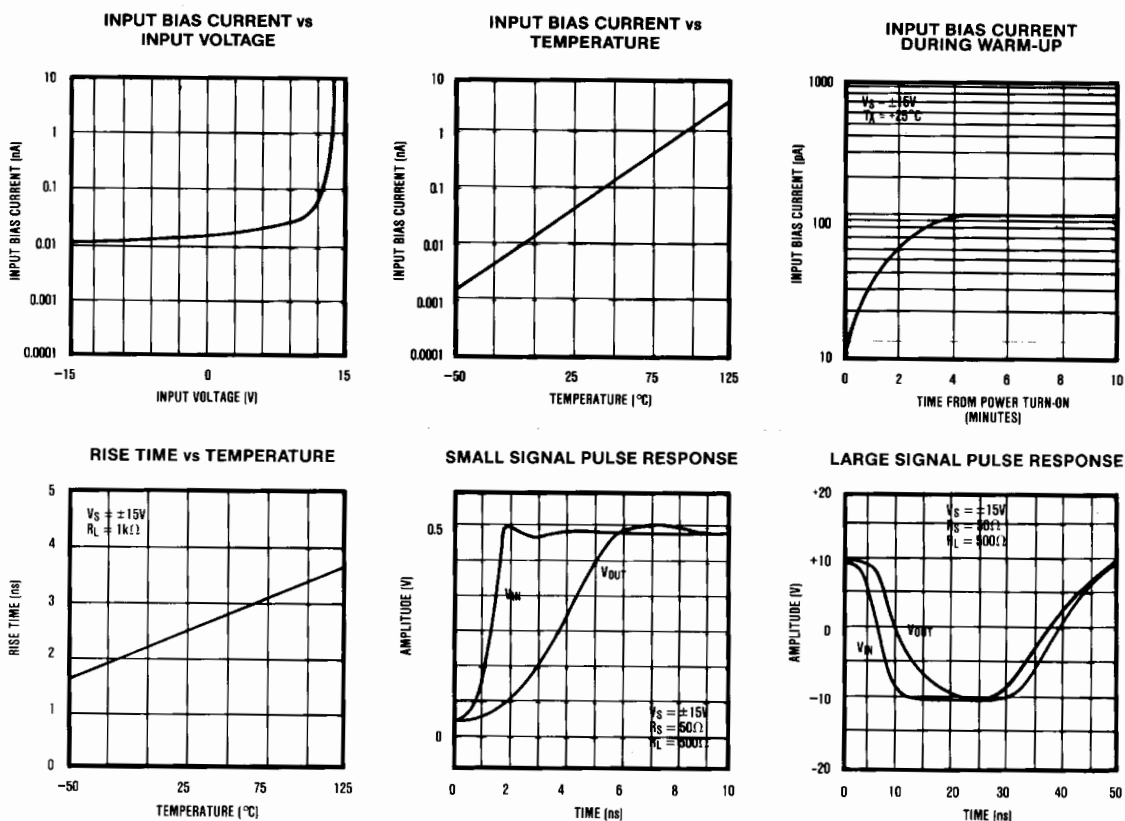

Figure 5. High Speed High Voltage Attenuator

Typical Operating Characteristics



High Accuracy Fast Buffer

MAX460

Typical Operating Characteristics

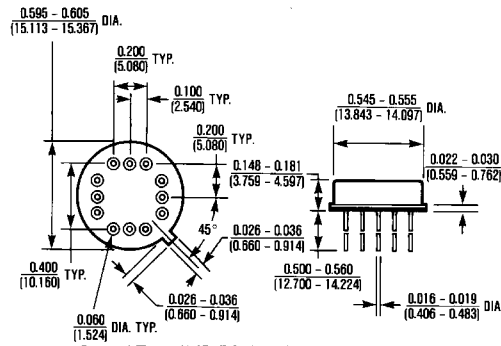
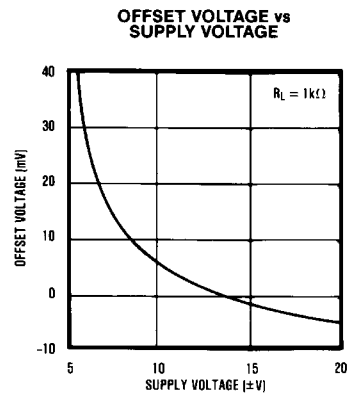
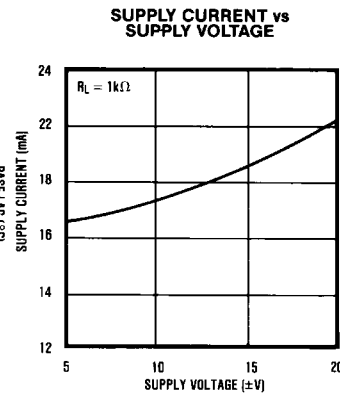
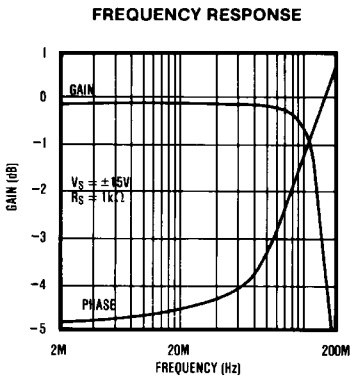
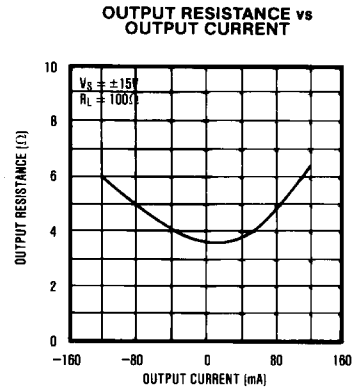
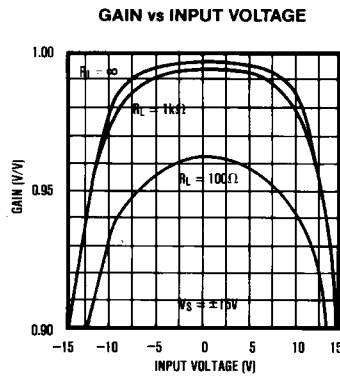
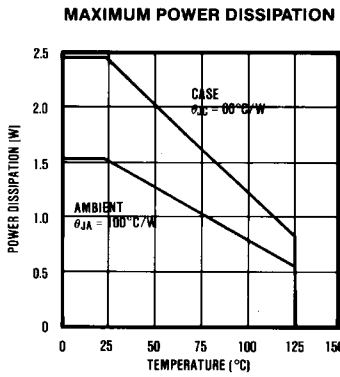

This datasheet has been downloaded from:

www.DatasheetCatalog.com

Datasheets for electronic components.



LittleDiode supplies new, hard to find or obsolete electronic components and semiconductors all over the world.

With over two million different components listed you are sure to find the part you need.

Feel free to visit us today at our online store:

LittleDiode.com

Looking forward to providing you with the best possible service.