

**Features**

- Low input current—50 pA
- Low offset and drift—  
2 mV/25  $\mu$ V/°C
- High slew rate—1500 V/ $\mu$ s
- Fast rise and fall time—2.5 ns
- High input resistance—1000 G $\Omega$
- Bandwidth—140 MHz
- Pin compatible with ELH0033
- MIL-STD-883 Revision C devices  
manufactured in U.S.A.

**Advantages**

- No input loading
- Input current independent of  
input voltage
- Eliminates offset adjustments
- Drives cables directly

**Ordering Information**

Part No.	Temp. Range	Package	Outline #
EL2005CG	-25°C to +85°C	TO-8	MDP0002
EL2005G	-55°C to +125°C	TO-8	MDP0002
EL2005G/883B	-55°C to +125°C	TO-8	MDP0002

**Connection Diagram**

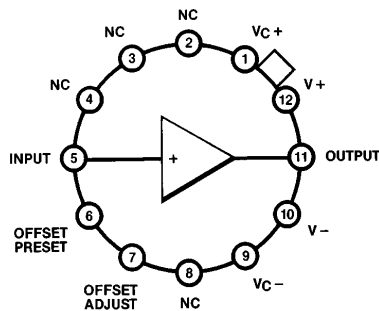

**Top View**

Note: Case is electrically isolated.

2005-1

**General Description**

The EL2005 is a high-speed, FET input buffer similar to ELH0033 and EL2004 but with input specifications significantly improved over the previous types. The input stage employs a cascode configuration to maintain constant input characteristics over the full  $\pm 10$ V input range. The input looks like a 3 pF capacitor to ground in almost all cases since the DC bias current is constant with input voltage. In sample and hold circuits this results in an order of magnitude improvement in hold characteristics. Input offset voltage and offset voltage drift are also improved a factor of two over previous types.

These excellent DC characteristics are complemented by a wide 140 MHz bandwidth while the 1500 V/ $\mu$ s slew rate and excellent phase linearity of the ELH0033 family are preserved allowing direct plug-in replacement for upgraded performance. (For even faster operation see EL2004.)

Elantec facilities comply with MIL-I-45208A and are MIL-STD-1772 certified. Elantec's Military devices comply with MIL-STD-883B Revision C and are manufactured in our rigidly controlled, ultra-clean facilities in Milpitas, California. For additional information on Elantec's Quality and Reliability Assurance Policy and procedures request brochure QRA-1.

**Simplified Schematic**

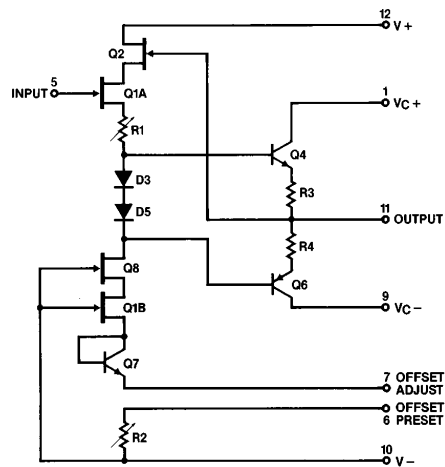

2005-2

Note: All information contained in this data sheet has been carefully checked and is believed to be accurate as of the date of publication; however, this data sheet cannot be a "controlled document". Current revisions, if any, to these specifications are maintained at the factory and are available upon your request. We recommend checking the revision level before finalization of your design documentation. Patent pending. CMS # 2005DS

# EL2005/EL2005C

## High Accuracy Fast Buffer

### Absolute Maximum Ratings ( $T_A = 25^\circ\text{C}$ )

$V_S$	Supply Voltage ( $V_+ - V_-$ )	40V	$T_A$	Operating Temperature Range	
$V_{IN}$	Input Voltage	40V		EL2005	$-55^\circ\text{C}$ to $+125^\circ\text{C}$
$P_D$	Power Dissipation (See curves)	1.5W		EL2005C	$-25^\circ\text{C}$ to $+85^\circ\text{C}$
$I_{OC}$	Continuous Output Current	$\pm 100$ mA	$T_J$	Operating Junction Temperature	175°C
$I_{OP}$	Peak Output Current	$\pm 250$ mA	$T_{ST}$	Storage Temperature	$-65^\circ\text{C}$ to $+150^\circ\text{C}$
				Lead Temperature	
				(Soldering, 10 seconds)	300°C

#### Important Note:

All parameters having Min/Max specifications are guaranteed. The Test Level column indicates the specific device testing actually performed during production and Quality inspection. Elantec performs most electrical tests using modern high-speed automatic test equipment, specifically the LTX77 Series system. Unless otherwise noted, all tests are pulsed tests, therefore  $T_J = T_C = T_A$ .

Test Level	Test Procedure
I	100% production tested and QA sample tested per QA test plan QCX0002.
II	100% production tested at $T_A = 25^\circ\text{C}$ and QA sample tested at $T_A = 25^\circ\text{C}$ , $T_{MAX}$ and $T_{MIN}$ per QA test plan QCX0002.
III	QA sample tested per QA test plan QCX0002.
IV	Parameter is guaranteed (but not tested) by Design and Characterization Data.
V	Parameter is typical value at $T_A = 25^\circ\text{C}$ for information purposes only.

### DC Electrical Characteristics $V_S = \pm 15\text{V}$ , $V_{IN} = 0\text{V}$ , $T_{MIN} \leq T_A \leq T_{MAX}$

Parameter	Description	Test Conditions	EL2005				EL2005C				Units
			Min	Typ	Max	Test Level	Min	Typ	Max	Test Level	
$V_{OS}$	Output Offset Voltage	$R_S \leq 100$ k $\Omega$ , $T_J = 25^\circ\text{C}$ (Note 1)		2	5	I		3	10	I	mV
		$R_S \leq 100$ k $\Omega$			10	I			15	III	mV
$\Delta V_{OS}/\Delta T$	Average Temperature Coefficient of Offset Voltage	$R_S = 100\Omega$		25		V		25		V	$\mu\text{V}/^\circ\text{C}$
PSRR	Supply Rejection	$\pm 10\text{V} \leq V_S \leq \pm 20\text{V}$	65	75		I	60	75		II	dB
$I_B$	Input Bias Current	$T_J = 25^\circ\text{C}$ (Notes 1 and 3)		2	50	I		5	100	I	pA
		$T_A = 25^\circ\text{C}$ (Notes 2 and 3)		50	500	IV		100	1000	IV	pA
		$T_J = T_A = T_{MAX}$		2	5	I		0.5	5	III	nA
$A_V$	Voltage Gain	$R_S = 100\Omega$ , $R_L = 1$ k $\Omega$ , $V_{IN} = \pm 10\text{V}$	0.97	0.98	1.0	I	0.96	0.98	1.0	II	V/V
		$R_S = 100\Omega$ , $R_L = 100\Omega$ , $V_{IN} = \pm 10\text{V}$	0.88	0.95	0.98	I	0.88	0.95	0.99	II	V/V
$R_{IN}$	Input Impedance	$R_L = 1$ k $\Omega$ , $-10\text{V} \leq V_{IN} \leq \pm 10\text{V}$	$2 \times 10^9$	$10^{12}$		I	$2 \times 10^9$	$10^{12}$		IV	$\Omega$
		$T_J = 25^\circ\text{C}$ (Note 1), $R_L = 1$ k $\Omega$	$10^{10}$	$10^{12}$		I	$10^{10}$	$10^{12}$		I	$\Omega$
$R_O$	Output Impedance	$R_L = 1$ k $\Omega$ , $V_{IN} = \pm 1\text{V}$		4	8	I		4	9	II	$\Omega$

# EL2005/EL2005C

## High Accuracy Fast Buffer

### DC Electrical Characteristics $V_S = \pm 15V, V_{IN} = 0V, T_{MIN} \leq T_A \leq T_{MAX}$ — Contd.

Parameter	Description	Test Conditions	EL2005				EL2005C				Units
			Min	Typ	Max	Test Level	Min	Typ	Max	Test Level	
V <sub>O</sub>	Output Voltage Swing	V <sub>IN</sub> = ±14V, R <sub>L</sub> = 1 kΩ		±12.5		V		±12.5		V	V
		V <sub>IN</sub> = ±10.5V, R <sub>L</sub> = 100Ω, T <sub>A</sub> = 25°C	±9	±9.8		I	±9	±9.8		I	V
I <sub>S</sub>	Supply Current	V <sub>IN</sub> = 0 (Note 1)		19	22	I		19	24	II	mA
PD	Power Consumption	V <sub>IN</sub> = 0		570	660	I		570	720	II	mW

### AC Electrical Characteristics $T_C = 25^\circ C, V_S = \pm 15V, R_S = 50\Omega, R_L = 1\text{ k}\Omega$

Parameter	Description	Test Conditions	EL2005				EL2005C				Units
			Min	Typ	Max	Test Level	Min	Typ	Max	Test Level	
SR	Slew Rate	V <sub>IN</sub> = ±10V, V <sub>OUT</sub> = ±5V	1000	1500		III	1000	1500		III	V/μs
BW	Bandwidth	V <sub>IN</sub> = 1 V <sub>rms</sub>		140		V		140		V	MHz
φ <sub>NL</sub>	Phase Non-Linearity	BW = 1 MHz to 20 MHz		2		V		2		V	Degree
t <sub>r</sub>	Rise Time	ΔV <sub>IN</sub> = 0.5V		2.5		V		2.5		V	ns
t <sub>p</sub>	Propagation Delay	ΔV <sub>IN</sub> = 0.5V		1.0		V		1.0		V	ns
HD	Harmonic Distortion	f > 1 kHz		<0.1		V		<0.1		V	%
A <sub>v</sub>	Voltage Gain	R <sub>S</sub> = 100Ω, V <sub>IN</sub> = 1 V <sub>rms</sub> , f = 1 kHz	0.97	0.99	1.0	I	0.96	0.99	1.0	II	V/V
R <sub>O</sub>	Output Impedance	V <sub>IN</sub> = 1 V <sub>rms</sub> , f = 1 kHz		4	8	I		4	9	II	Ω

Note 1: Specification is at 25°C junction temperature due to requirements of high-speed automatic testing. Actual values at operating temperatures will exceed the value at T<sub>J</sub> = 25°C. When supply voltages are ±15V, no-load operating junction temperatures may rise 40°C to 60°C above ambient and more under load conditions. Accordingly, V<sub>OS</sub> may change one to several mV, and I<sub>B</sub> will change significantly during warm-up. Refer to I<sub>B</sub> vs Temperature graph for expected values.

Note 2: Measured in still air seven minutes after application of power.

Note 3: Input bias current is guaranteed over the input range of -10V ≤ V<sub>IN</sub> ≤ +10V.

# EL2005/EL2005C

## High Accuracy Fast Buffer

### Typical Performance Curves

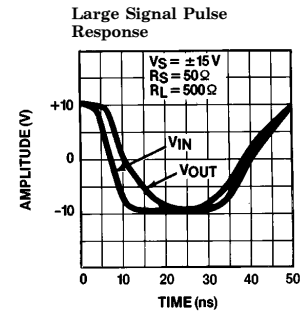
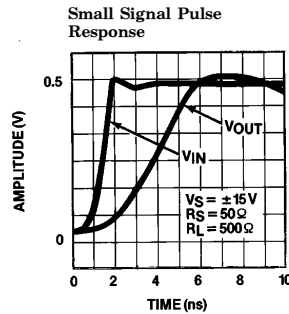
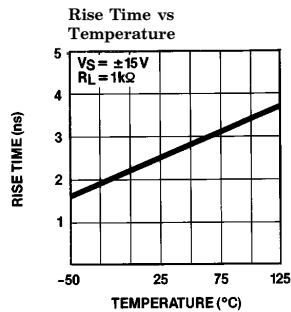
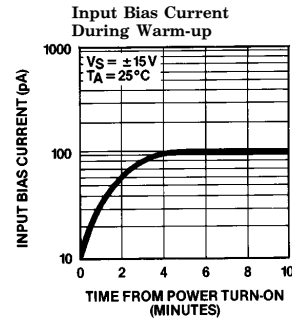
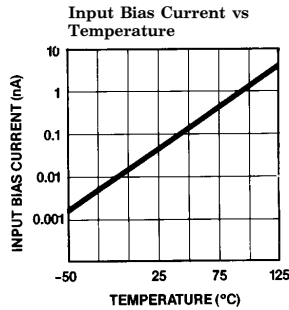
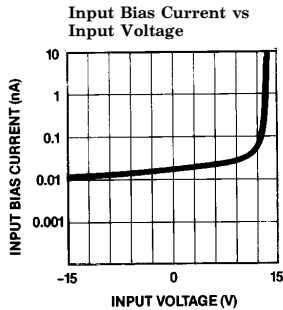
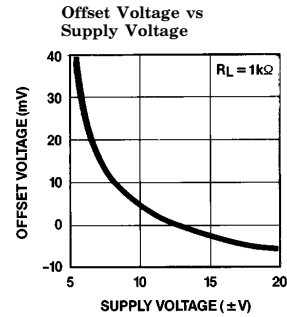
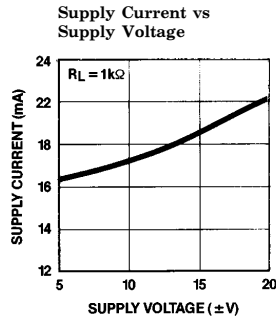
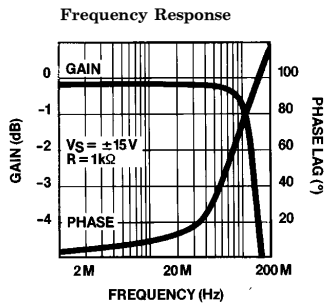
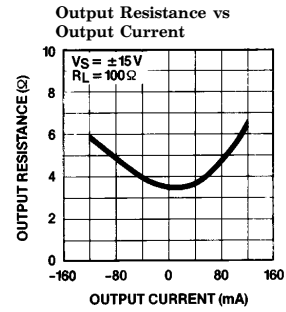
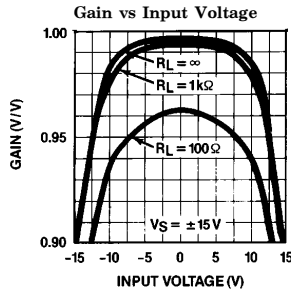
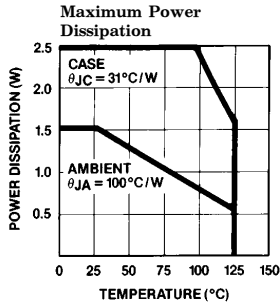

2005-3

2005-4

# EL2005/EL2005C

## High Accuracy Fast Buffer

### Typical Applications

Offset Zero Adjust

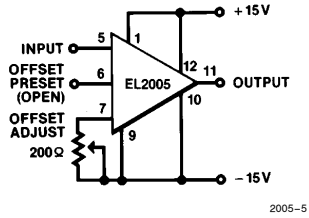

Using Resistor Current Limiting

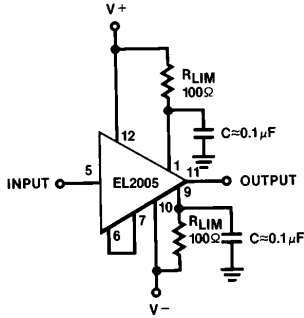

Current Limiting Using Current Sources

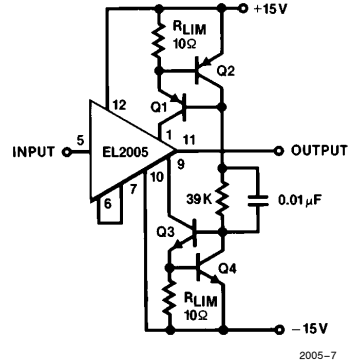

Q1 = Q2 = 2N2905  
Q3 = Q4 = 2N2219

High Input Impedance AC Coupled Amplifier

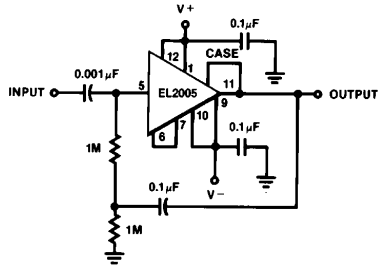

Coaxial Cable Driver

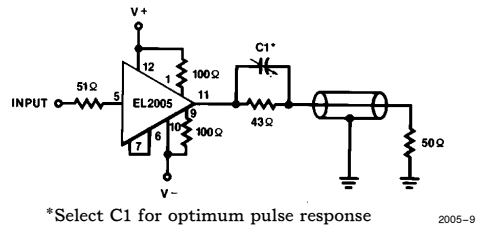

# EL2005/EL2005C

## High Accuracy Fast Buffer

### Typical Applications — Contd.

**50Ω Cable Driver with Short Circuit Protection**

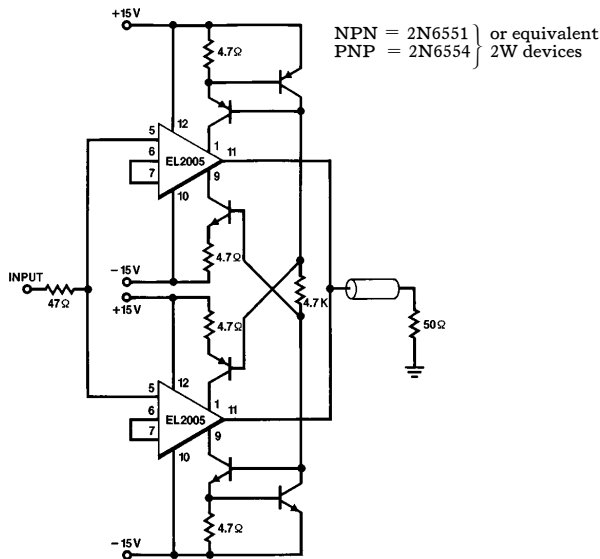

2005-10

**Bootstrapped Supplies for High Voltage Applications**

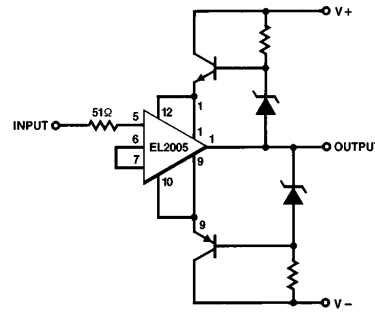

2005-11

**High-Speed Sample and Hold**

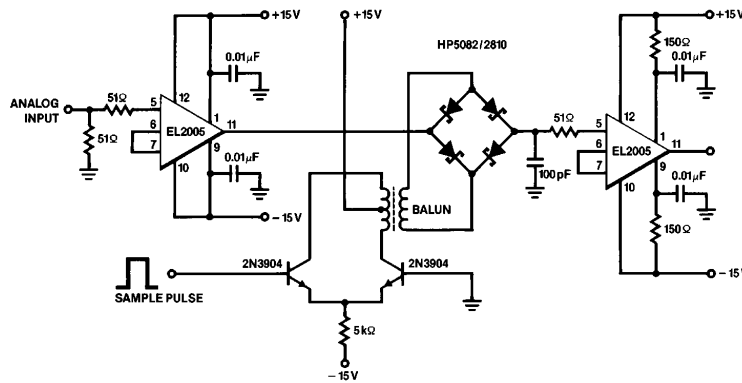

2005-12

# *EL2005/EL2005C*

## *High Accuracy Fast Buffer*

### Applications Information

#### Recommended Layout Precautions

RF/video printed circuit board layout rules should be followed when using the EL2005 since it will provide power gain to frequencies over 100 MHz. Ground planes are recommended and power supplies should be decoupled at each device with low inductance capacitors. In addition, ground plane shielding may be extended to the metal case of the device since it is electrically isolated from internal circuitry. Alternatively, the case should be connected to the output to minimize input capacitance.

#### Offset Voltage Adjustment

The EL2005's offset voltages have been actively trimmed by laser to meet guaranteed specifications when the offset preset pin is shorted to the offset adjust pin. The pre-calibration allows the devices to be used in most DC or AC applications without individually offset nulling each device. If offset null is desirable, it is simply obtained by leaving the offset preset pin open and connecting a trim pot of 200Ω between the offset adjust pin and V<sup>-</sup> as illustrated on page 4.

#### Operation from Single or Asymmetrical Power Supplies

This device type may be readily used in applications where symmetrical supplies are unavailable or not desirable. In this case, an apparent output offset occurs due to the device's voltage gain of less than unity. This additional output offset error may be predicted by:

$$\Delta V_O \cong (1 - A_V) \frac{(V^+ - V^-)}{2} = 0.005 (V^+ - V^-)$$

where: A<sub>V</sub> = No load voltage gain, typically 0.99  
V<sup>+</sup> = Positive supply voltage  
V<sup>-</sup> = Negative supply voltage

For example, with V<sup>+</sup> = +5V and V<sup>-</sup> = -12V, ΔV<sub>O</sub> would be -35 mV. This may be adjusted to zero as described above.

#### Short Circuit Protection

In order to optimize transient response and output swing, output current limit has been omitted from the EL2005. Short circuit protection may be added by inserting appropriate value resistors between V<sup>+</sup> and V<sub>C+</sub> pins and V<sup>-</sup> and V<sub>C-</sub> pins as shown on page 4.

Resistor values may be predicted by:

$$R_{LIM} \cong \frac{V^+}{I_{SC}} = \frac{V^-}{I_{SC}}$$

where: I<sub>SC</sub> ≤ 100 mA for EL2005

The inclusion of limiting resistors in the collectors of the output transistors reduces output voltage swing. Decoupling V<sub>C+</sub> and V<sub>C-</sub> pins with capacitors to ground will retain full output swing for transient pulses. An alternate active current limit technique that retains full DC output swing is also shown on page 4. In this circuit, the current sources are saturated during normal operation thus applying full supply voltage to the V<sub>C</sub> pins. Under fault conditions, the voltage decreases as required by the overload.

$$R_{LIM} \cong \frac{V_{BE}}{I_{SC}} = \frac{0.6V}{60 \text{ mA}} = 10\Omega$$

#### Capacitive Loading

The EL2005 is designed to drive capacitive loads such as coaxial cables in excess of several thousand picofarads without susceptibility to oscillation. However, peak current resulting from (C × dV/dt) should be limited below absolute maximum peak current ratings for the devices.

Thus:

$$\frac{\Delta V_{IN}}{\Delta t} \times C_L \leq I_{OUT} \leq \pm 250 \text{ mA}$$

In addition, power dissipation resulting from driving capacitive loads plus standby power should be kept below the total package power rating:

$$P_{Dpkg} \geq P_{DC} + P_{AC}$$

$$P_{Dpkg} \geq (V^+ - V^-) \times I_S + P_{AC}$$

$$P_{AC} \cong (V_{P-P})^2 \times f \times C_L$$

where: V<sub>P-P</sub> = Peak-to-peak output voltage swing

f = Frequency

C<sub>L</sub> = Load Capacitance

# EL2005/EL2005C

## High Accuracy Fast Buffer

### Applications Information — Contd.

#### Operation within an Op Amp Loop

The EL2005 may be used as a current booster or isolation buffer within a closed loop with op amps such as the ELH0032 and HA2500 and HA2600 series. An isolation resistor of  $47\Omega$  should be used between the op amp output and the input of EL2005. The wide bandwidth and high slew rates of the EL2005 assure that the loop has the characteristics of the op amp and that additional rolloff is not required.

#### Burn-In Circuit

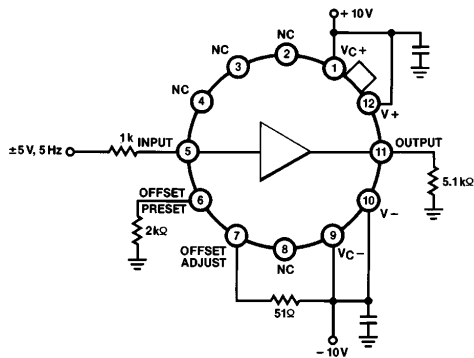

2005-13

#### Hardware

In order to utilize the full drive capabilities of the EL2005, it should be mounted with a heatsink, particularly for extended temperature operation. The case is isolated from the circuit and may be connected to system chassis.

#### IMPORTANT!

Power supply bypassing is necessary to prevent oscillation with the EL2005 in all circuits. Low inductance ceramic disc capacitors with the shortest practical lead lengths must be connected from each supply lead (within  $\frac{1}{4}$ " to  $\frac{1}{2}$ " of the device package) to a ground plane. Capacitors should be one or two  $0.1\mu\text{F}$  in parallel; adding a  $4.7\mu\text{F}$  solid tantalum capacitor will help in troublesome instances.

# ***EL2005/EL2005C***

## ***High Accuracy Fast Buffer***

### **EL2005 Macromodel**

```

* Connections:      input
*                  |
*                  | V+
*                  |
*                  | +Vc+
*                  |
*                  | V-
*                  |
*                  | Vc-
*                  |
*                  | output
*                  |
.subckt M2005      5      12      1      10      9      11
* Models
.model qn npn (is = 5e-14 bf = 150 vaf = 100 rc = 1 rb = 5 re = 1 ikf = 200mA
+ cje = 5pF cjc = 5pF mje = .42 mjc = .23 tf = .3nS tr = 200nS br = 5 vtf = 0)
.model qp npn (is = 5e-14 bf = 150 vaf = 100 rc = .2 rb = 3 re = 1 ikf = 100mA
+ cje = 5.7pF cjc = 4pF tf = .3nS mje = .32 mjc = .43 tr = 170nS br = 5 vtf = 0)
.model qfa njf (vto = -8V beta = 2.344e-3 cgd = 10pF cgs = 7pF lambda = 671e-6)
.model qfb njf(vto = -4V beta = 1.06e-3 cgd = 3pF cgs = 3pF)
* Resistors
r1 21 22 30
r2 7 10 30
r3 25 11 3
r4 11 26 3
* Transistors
j1a 20 5 21 qfb
j1b 28 10 27 qfb
j2 12 11 20 qfa
j4 24 10 28 qfa
q3 22 22 23 qn
q4 1 22 25 qn
q5 24 24 23 qp
q6 9 24 26 qp
q7 27 27 7 qn
.ends

```

# *EL2005/EL2005C*

*High Accuracy Fast Buffer*

## EL2005 Macromodel — Contd.

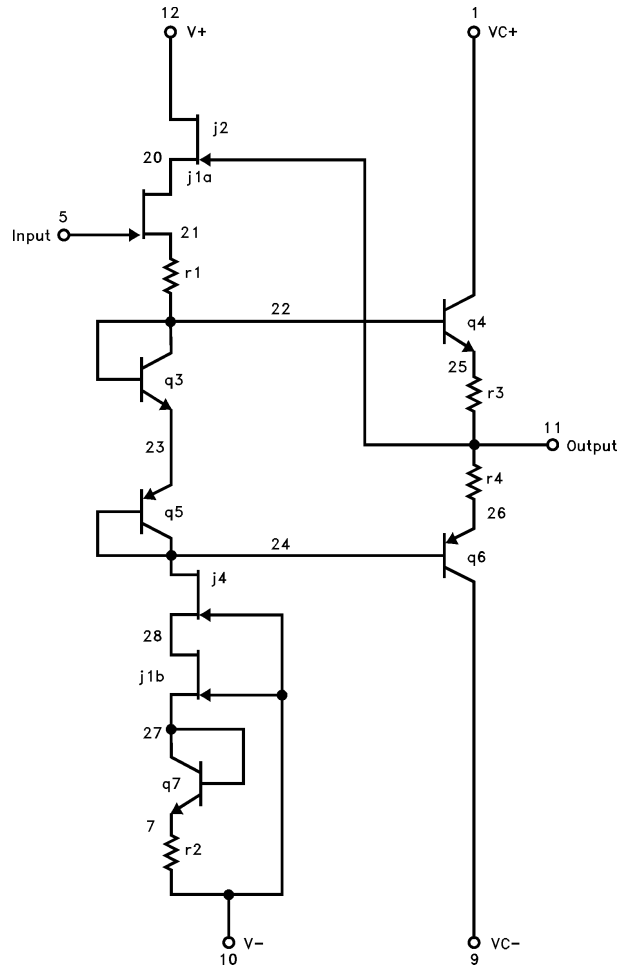

2005-14

**BLANK**

# ***EL2005/EL2005C***

## ***High Accuracy Fast Buffer***

### **General Disclaimer**

Specifications contained in this data sheet are in effect as of the publication date shown. Elantec, Inc. reserves the right to make changes in the circuitry or specifications contained herein at any time without notice. Elantec, Inc. assumes no responsibility for the use of any circuits described herein and makes no representations that they are free from patent infringement.

***élantec***  
HIGH PERFORMANCE ANALOG INTEGRATED CIRCUITS

### **Elantec, Inc.**

1996 Tarob Court

Milpitas, CA 95035

Telephone: (408) 945-1323

(800) 333-6314

Fax: (408) 945-9305

European Office: 44-71-482-4596

### **WARNING — Life Support Policy**

Elantec, Inc. products are not authorized for and should not be used within Life Support Systems without the specific written consent of Elantec, Inc. Life Support systems are equipment intended to support or sustain life and whose failure to perform when properly used in accordance with instructions provided can be reasonably expected to result in significant personal injury or death. Users contemplating application of Elantec, Inc. products in Life Support Systems are requested to contact Elantec, Inc. factory headquarters to establish suitable terms & conditions for these applications. Elantec, Inc.'s warranty is limited to replacement of defective components and does not cover injury to persons or property or other consequential damages.



LittleDiode supplies new, hard to find or obsolete electronic components and semiconductors all over the world.

With over two million different components listed you are sure to find the part you need.

Feel free to visit us today at our online store:

[LittleDiode.com](http://LittleDiode.com)

Looking forward to providing you with the best possible service.