

## Features

- Novel current mode design  
Virtual ground current summing inputs  
Differential ground referenced current outputs
- High speed (both inputs)  
200 MHz bandwidth  
12 ns 1% settling time
- Low distortion  
THD < 0.03% @ 1 MHz  
THD < 0.1% @ 10 MHz
- Low noise ( $R_L = 50\Omega$ )  
100 dB dynamic range  
10 Hz to 20 kHz  
73 dB dynamic range  
10 Hz to 10 MHz
- Wide supply conditions  
 $\pm 5$  to  $\pm 15V$  operation  
Programmable bias current
- 0.2 dB gain tolerance to 25 MHz

## Applications

- Four quadrant multiplication
- Gain control
- Controlled signal summing and multiplexing
- HDTV video fading and switching
- Mixing/modulating/demodulating (phase detection)
- Frequency doubling
- Division
- Squaring
- Square rooting
- RMS and power measurement
- Vector addition-RMS summing
- CRT focus and geometry correction
- Polynomial function generation
- AGC circuits

## Ordering Information

Part No.	Temp. Range	Package	Outline #
EL4083CN	-40°C to +85°C	8-Pin P-DIP	MDP0031
EL4083CS	-40°C to +85°C	8-Pin SO	MDP0027

## General Description

The 4083C makes use of an Elantec fully complimentary oxide isolated bipolar process to produce a patent pending current in, current out four quadrant multiplier. Input and output signal summing and direct interface to other current mode devices can be accomplished by simple connection to reduce component count and preserve bandwidth. The selection of an appropriate series resistor value allows an input to accept a voltage signal of any size and optimize dynamic range. The differential outputs offer significant performance improvements which greatly extend the usable gain control range at high frequencies. The bias current is programmable to accommodate the voltage and power dissipation constraints of the package and available systems supplies.

The devices can implement all the classic four quadrant multiplier applications and are uniquely well suited to gain control and signal summing of broadband signals.

## Connection Diagram

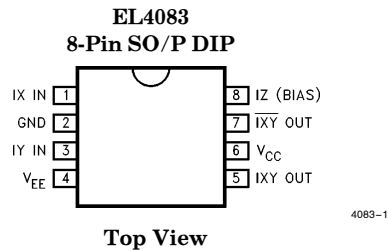

Manufactured under U.S. Patent No. 5,389,840

Note: All information contained in this data sheet has been carefully checked and is believed to be accurate as of the date of publication; however, this data sheet cannot be a "controlled document". Current revisions, if any, to these specifications are maintained at the factory and are available upon your request. We recommend checking the revision level before finalization of your design documentation.

© 1993 Elantec, Inc.

# EL4083C

## Current Mode Four Quadrant Multiplier

### Absolute Maximum Ratings ( $T_A = 25^\circ\text{C}$ )

$V_S$	Voltage between $V_S+$ and $V_S-$	+33V	$T_J$	Operating Junction Temperature	
$I_Z(\text{BIAS})$	Z, Bias Current	+2.4 mA		EL4083	150°C
$I_X$	X Input Current	$\pm 2.4$ mA	$T_{ST}$	Storage Temperature	-65°C to +150°C
$I_Y$	Y Input Current	$\pm 2.4$ mA			
$P_D$	Maximum Power Dissipation	See Curves			
$T_A$	Operating Temperature Range	-40°C to +85°C			

#### Important Note:

All parameters having Min/Max specifications are guaranteed. The Test Level column indicates the specific device testing actually performed during production and Quality inspection. Elantec performs most electrical tests using modern high-speed automatic test equipment, specifically the LTX77 Series system. Unless otherwise noted, all tests are pulsed tests, therefore  $T_J = T_C = T_A$ .

Test Level	Test Procedure
I	100% production tested and QA sample tested per QA test plan QCX0002.
II	100% production tested at $T_A = 25^\circ\text{C}$ and QA sample tested at $T_A = 25^\circ\text{C}$ , $T_{MAX}$ and $T_{MIN}$ per QA test plan QCX0002.
III	QA sample tested per QA test plan QCX0002.
IV	Parameter is guaranteed (but not tested) by Design and Characterization Data.
V	Parameter is typical value at $T_A = 25^\circ\text{C}$ for information purposes only.

### Electrical Characteristics ( $T_A = 25^\circ\text{C}$ , $V_S = \pm 5$ , $I_Z = 1.6$ mA) unless otherwise specified

Parameter	Conditions	Min	Typ	Max	Test Level	Units
<b>Power Supplies</b>						
Operating Supply Voltage Range		$\pm 4.5$		$\pm 16.5$	I	V
$I_{CC}$	$V_S = \pm 15\text{V}$ , $I_Z = 0.2$ mA	7.2	8.5	9.5	I	mA
$I_{CC}$	$V_S = \pm 5\text{V}$ , $I_Z = 1.6$ mA	42.0	44.0	45	I	mA
$I_{EE}$	$V_S = \pm 15\text{V}$ , $I_Z = 0.2$ mA	9.5	10.0	12	I	mA
$I_{EE}$	$V_S = \pm 5\text{V}$ , $I_Z = 1.6$ mA	45	47	48	I	mA
<b>Multiplier Performance</b>						
Transfer Function (Note 5)	$(I_{XY} - I_{\overline{XY}}) = K(I_X \times I_Y) / I_Z$					
K Value		0.92	0.965	1.01	I	
Total Error (Note 1)	$-2$ mA $< I_X, I_Y < 2$ mA		$\pm 0.5$	$\pm 2$	I	%FS
vs. Temp	$T_{MIN}$ to $T_{MAX}$		$\pm 1.5$	$\pm 3$	IV	%FS
Linearity (Note 2)			0.25	0.5	I	%FS
Bandwidth (Note 3)	-3 dB (See Figure 2)	200	225		III	MHz
X Feedthrough DC to $I_{XY}$ or $I_{\overline{XY}}$ (Note 5)	$I_X = \pm 2$ mA, $I_Y = 0$ (unnullified)		0.15	1.6	I	%FS
Y Feedthrough DC to $I_{XY}$ or $I_{\overline{XY}}$ (Note 5)	$I_Y = \pm 2$ mA, $I_X = 0$ (unnullified)		0.15	1.6	I	%FS
AC Feedthrough, X to $I_{XY}$ or $I_{\overline{XY}}$ (Note 4)	$I_X = 4$ mApp, $I_Y =$ nulled					
	$f = 3.58$ MHz			-80	V	dB
	$f = 100$ MHz			-28	V	dB
AC Feedthrough, X to $(I_{XY} - I_{\overline{XY}})$ (Note 4)	$I_X = 4$ mApp, $I_Y =$ nulled			-50	V	dB
	DC $< f < 1$ GHz					
AC Feedthrough, Y to $I_{XY}$ or $I_{\overline{XY}}$ (Note 4)	$I_Y = 4$ mApp, $I_X =$ nulled					
	$f = 3.58$ MHz			-64	V	dB
	$f = 100$ MHz			-26	V	dB
AC Feedthrough, Y to $(I_{XY} - I_{\overline{XY}})$ (Note 4)	$I_Y = 4$ mApp, $I_X =$ nulled			-50	V	dB
	DC $< f < 1$ GHz					

# EL4083C

## Current Mode Four Quadrant Multiplier

### Electrical Characteristics — Contd. ( $T_A = 25^\circ\text{C}$ , $V_S = \pm 5$ , $I_Z = 1.6\text{ mA}$ ) unless otherwise specified

Parameter	Conditions	Min	Typ	Max	Test Level	Units
<b>Inputs (<math>I_X</math>, <math>I_Y</math>)</b>						
Full Scale Range	FRS = $1.25 \times I_Z$ (Nominal)		$\pm 2$		I	mA
Clipping Level	$C_L = 2 \times I_Z$	2.85	3.2		I	mA
$Z_{IN}$ ( $I_X$ )		30	40	48	I	$\Omega$
$Z_{IN}$ ( $I_Y$ )		30	36	48	I	$\Omega$
Input Offset Voltages ( $V_{OSX}, V_{OSY}$ )	at Input Pins, $I_Z = 1.6\text{ mA}$	-4		+4		mV
Input Offset Currents (Note 5)	$I_Z = 0.2\text{ mA}$	-12		+12		mV
$I_{XOS}, I_{YOS}$	$R_{SX} = R_{SY} = 1\text{K}$ , $V_X = V_Y = 0$ , $T_{MIN}$ to $T_{MAX}$		$\pm 10$	$\pm 40$	I	$\mu\text{A}$
Nonlinearity			$\pm 20$		V	nA/ $^\circ\text{C}$
$I_X$	$I_Y = 2\text{ mA}$ , $-2\text{ mA} < I_X < 2\text{ mA}$		0.1	0.6	I	%FS
$I_Y$	$I_X = 2\text{ mA}$ , $-2\text{ mA} < I_Y < 2\text{ mA}$		0.1	0.4	I	%FS
Distortion, $I_X$ (to $I_{XY}$ or $I_{\overline{XY}}$ )	$I_Y = 2\text{ mA}$ , $-2\text{ mA} < I_X < 2\text{ mA}$					
	$f = 3.58\text{ MHz}$			-55	V	dB
	$f = 100\text{ MHz}$			-25	V	dB
Distortion, $I_Y$ (to $I_{XY}$ or $I_{\overline{XY}}$ )	$I_X = 2\text{ mA}$ , $-2\text{ mA} < I_Y < 2\text{ mA}$					
	$f = 3.58\text{ MHz}$			-56	V	dB
	$f = 100\text{ MHz}$			-26	V	dB
Distortion, $I_X$ (to $(I_{XY} - I_{\overline{XY}})$ )	$I_Y = 2\text{ mA}$ , $-2\text{ mA} < I_X < 2\text{ mA}$					
	$f = 3.58\text{ MHz}$			-66	V	dB
	$f = 100\text{ MHz}$			-35	V	dB
Distortion, $I_Y$ (to $(I_{XY} - I_{\overline{XY}})$ )	$I_X = 2\text{ mA}$ , $-2\text{ mA} < I_Y < 2\text{ mA}$					
	$f = 3.58\text{ MHz}$			-66	V	dB
	$f = 100\text{ MHz}$			-34	V	dB
Diff Gain	@3.58 MHz					
$I_X$	$I_Z = 0.2\text{ mA}$ , $I_Y = 0.25\text{ mA}$		0.2		V	%
$I_Y$	$I_Z = 0.2\text{ mA}$ , $I_X = 0.25\text{ mA}$		0.17		V	%
$I_X$	$I_Z = 1.6\text{ mA}$ , $I_Y = 2\text{ mA}$		0.1		V	%
$I_Y$	$I_Z = 1.6\text{ mA}$ , $I_X = 2\text{ mA}$		0.05		V	%
Diff Phase	@3.58 MHz					
$I_X$	$I_Z = 0.2\text{ mA}$ , $I_Y = 0.25\text{ mA}$		0.5		V	deg $^\circ$
$I_Y$	$I_Z = 0.2\text{ mA}$ , $I_X = 0.25\text{ mA}$		0.5		V	deg $^\circ$
$I_X$	$I_Z = 1.6\text{ mA}$ , $I_Y = 2\text{ mA}$		0.05		V	deg $^\circ$
$I_Y$	$I_Z = 1.6\text{ mA}$ , $I_X = 2\text{ mA}$		0.05		V	deg $^\circ$
<b>Outputs (<math>I_{XY}</math>, <math>I_{\overline{XY}}</math>)</b>						
Output $I_{OS}$ (Note 5)	$I_X = I_Y = 0$		-15	$\pm 120$	I	$\mu\text{A}$
Diff Output $I_{OS}$ (Note 5)	$I_X = I_Y = 0$ , $(I_{XY} - I_{\overline{XY}})$		$\pm 0.1$	$\pm 80$	I	$\mu\text{A}$
Voltage Compliance		$\pm 1.5$	$\pm 2.0$		V	V
Max Output Current Swing		$\pm 2.85$	$\pm 3.2$		I	mA
Noise Spectral Density 10 Hz < f < 10 MHz	$R_L = 50\Omega$			125	V	pA/rootHz
<b><math>I_Z</math> (Bias)</b>						
Current Range	Tested	0.2		1.6	I	mA
Input Voltage	$I_Z = 0.2\text{ mA}$			$\pm 25$	I	mV
Input Voltage	$I_Z = 1.6\text{ mA}$			$\pm 25$	I	mV

Note 1: Error is defined as the maximum deviation from the ideal transfer function expressed as a percentage of the full scale output.

Note 2: Linearity is defined as the error remaining after compensating for scale factor (gain) variation and input and output referred offset errors.

Note 3: Bandwidth is guaranteed using the squaring mode test circuit of Figure 4.

Note 4: Relative to full scale output with full scale sine wave on signal input and zero port input nulled. Specification represents feedthrough of the fundamental.

Note 5: Specifications are provisional for the EL4083.

# EL4083C

## Current Mode Four Quadrant Multiplier

### EL4083 Block Diagram

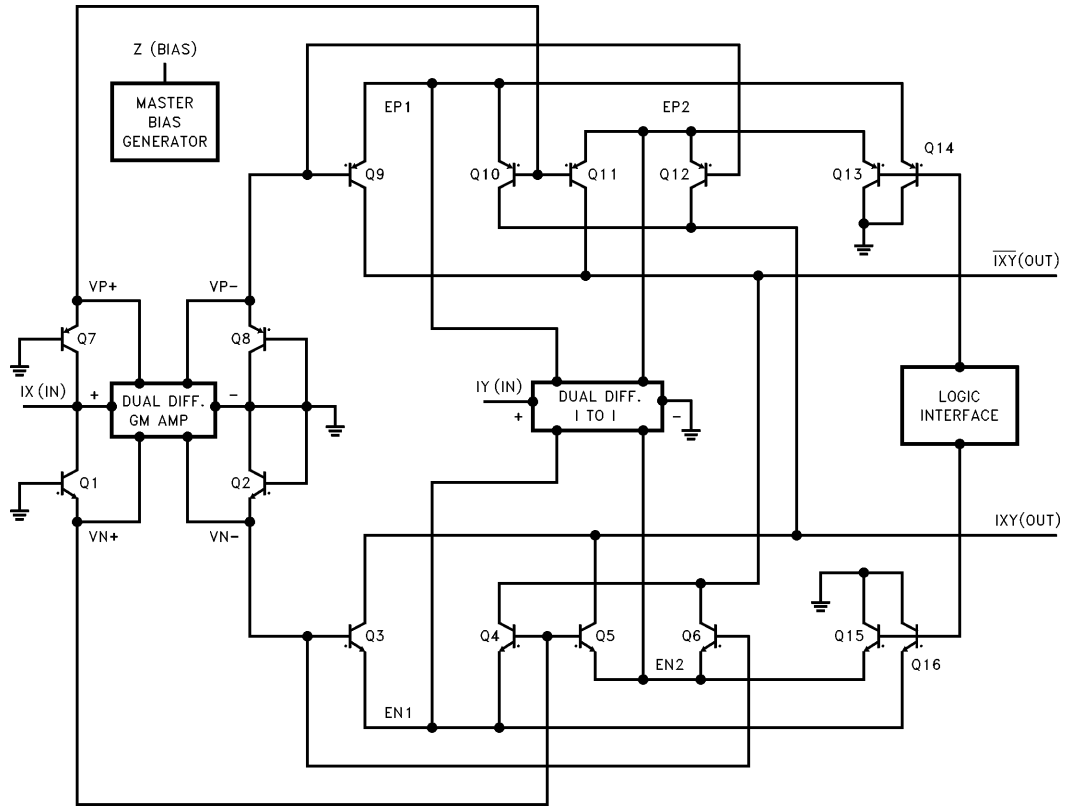

Figure 1

4083-3

# *EL4083C*

## *Current Mode Four Quadrant Multiplier*

### AC Test Fixture

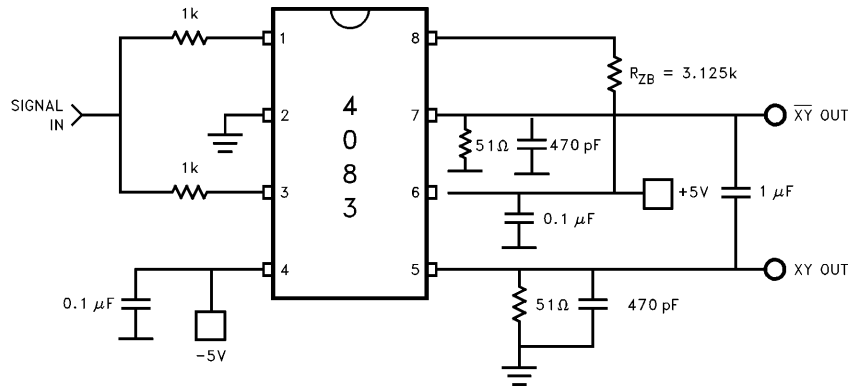
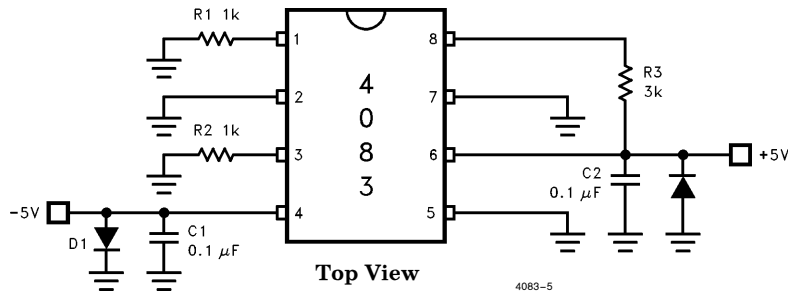

Figure 2. AC Bandwidth Test Fixture

4083-4

### Burn-In Circuit



Top View

4083-5

Figure 3. Burn-In Circuit P-DIP

# EL4083C

## Current Mode Four Quadrant Multiplier

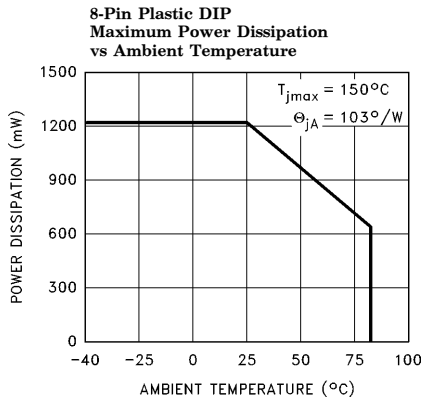

Figure 4

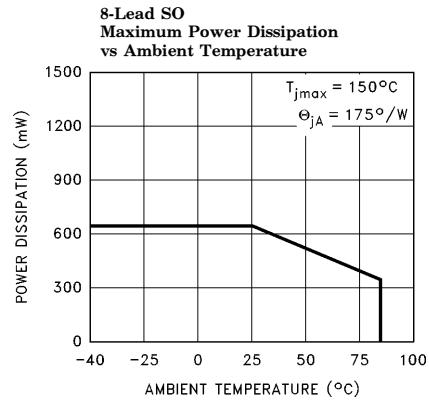

Figure 5

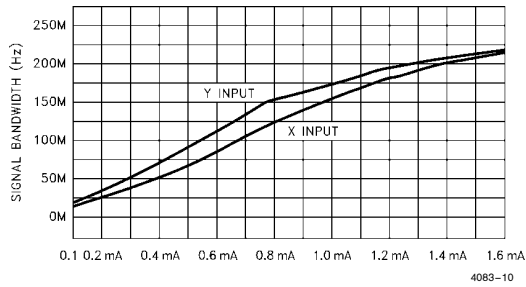

Figure 6. ( $I_X$ ,  $I_Y$  Bandwidth vs  $I_Z$ )

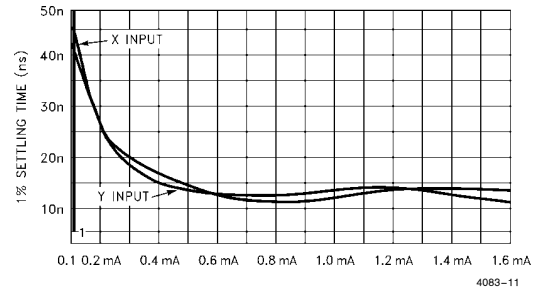

Figure 7. ( $I_X$ ,  $I_Y$  1% Settling Time vs  $I_Z$ )

# EL4083C

## Current Mode Four Quadrant Multiplier

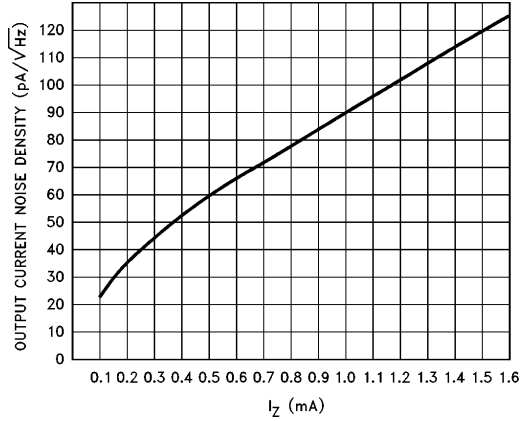

Figure 8. Output Noise Density vs  $I_Z$  Bias

4083-12



$$R_{TI} = (V_S \times 1.6 \text{ mA}) / (16 \mu\text{A} \times I_Z)$$

4083-13

$$R_{TO} = (V_S \times 1.6 \text{ mA}) / (30 \mu\text{A} \times I_Z)$$

4083-14

Figure 9. Optional External Trim Networks

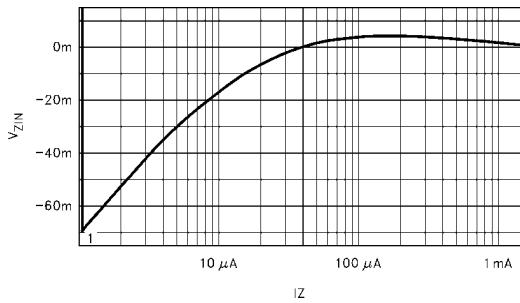

Figure 10.  $V_{ZIN}$  vs  $I_Z$  (Typical)

4083-15

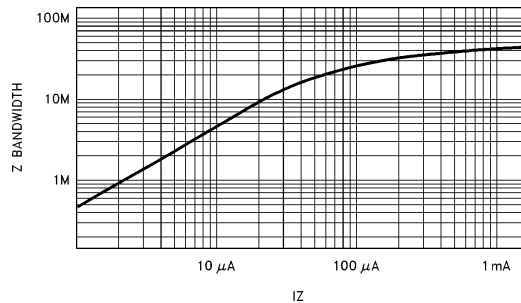

Figure 11.  $I_{ZIN}$  Bandwidth vs  $I_Z$

4083-16

# EL4083C

## Current Mode Four Quadrant Multiplier

### General Operating Information

#### I<sub>Z</sub> Input (Bias, Divisor) and Power Supplies

The I<sub>Z</sub> pin is a low impedance (< 20Ω) virtual ground current input. It can accept positive current from a resistor connected to a positive voltage source or the positive supply. The instantaneous bias for the multiplier gain core is proportional to this current value. Negative applied current will put the multiplier portion of the circuit in a zero bias state and the voltage at the pin will be clamped at a diode drop below ground. The part will respond in a similar manner to currents from a current source such as the output of a transconductance amplifier or one of its own outputs. The overall transfer equation for the EL4083 is:

$$K(I_X \times I_Y)/I_Z = (I_{XY} - I_{\overline{XY}}), K \sim 1$$

As can be seen from the equation, the Z input can serve as a divisor input. However, it is different from the other two inputs in that the value of its current determines the supply current of the part and the bandwidth and compliance range of the outputs and other two inputs. Table 1 gives the equations describing these and other important relationships. These dependencies can complicate and/or limit the usefulness of this pin as a computational input. The I<sub>Z</sub> dependence of the impedance of the multiplying inputs can be particularly troublesome. See the I<sub>Z</sub> divider and the RMS#2 circuit sections of the application note for some ways of dealing with this.

The primary intended use for the Z input is as a programming pin similar in function to those on programmable op amps. This enables one to trade off power consumption against bandwidth and settling time and allow the part to function within its power dissipation rating over its full operational supply range ( $\pm 4.5V - \pm 16.5V$ ). The E4083 has been designed to function well for I<sub>Z</sub> values in the range of  $200 \mu A < I_Z < 1.6 \text{ mA}$  which corresponds to I<sub>X</sub> and I<sub>Y</sub> signal bandwidths of about 50 MHz to over 200 MHz. Higher values of I<sub>Z</sub> may cause problems at temperature extremes while lower values down to zero will progressively degrade the input referred D.C. offsets and reduce speed. Below about 50  $\mu A$  of bias current the internal servo amplifier loop which maintains the I<sub>Z</sub> pin at ground will lose regulation and the voltage at the pin will start to move negative (see Figure 10). This is accompanied by a significant increase in input impedance of the pin. Figure 11 shows the A.C. bandwidth of the I<sub>Z</sub> input as a function of the D.C. value of I<sub>Z</sub>. Figures 6 and 7 show the bandwidth and 1% settling time of the multiplying inputs, I<sub>X</sub> and I<sub>Y</sub>, as functions of I<sub>Z</sub>.

#### I<sub>X</sub> and I<sub>Y</sub> (Multiplier) Inputs and Offset Trimming

The I<sub>X</sub> and I<sub>Y</sub> pins are low impedance (I<sub>Z</sub> dependent) virtual ground current inputs that accept bipolar signals. The input referred clip value is equal to I<sub>Z</sub> × 2 while the full scale value has been chosen to be 1.25 × I<sub>Z</sub> to maintain excellent distortion and linearity performance. Operating at higher full scale values will degrade these two pa-

Table 1. Basic Design Equations and Relationships

Positive Supply Current	I <sub>S+</sub> = 3.4 mA + I <sub>Z</sub> × 26
Negative Supply Current	I <sub>S-</sub> = 4.5 mA + I <sub>Z</sub> × 27
Power Dissipation (See Figures 4 and 5)	PWR = (+V <sub>S</sub> - (-V <sub>S</sub> )) × (4 mA + I <sub>Z</sub> × 26.5)
Multiplying Input(s) Impedance	R <sub>ZX</sub> = R <sub>ZY</sub> = (32Ω) × 1.6 mA/I <sub>Z</sub>
Multiplying Input(s) Clip Point	I <sub>X</sub> (clip) = I <sub>Y</sub> (clip) = I <sub>Z</sub> × 2
Multiplying Input(s) Full Scale Value	I <sub>X</sub> (fs) = I <sub>Y</sub> (fs) = I <sub>Z</sub> × 1.25 (nominal)
Multiplying Input Resistor Values (In Terms of Peak Input Signal)	R <sub>X</sub> = V <sub>X</sub> (peak)/I <sub>X</sub> (fs) R <sub>Y</sub> = V <sub>Y</sub> (peak)/I <sub>Y</sub> (fs)
Full Scale Output (Single Ended)	I <sub>XY</sub> = I <sub><math>\overline{XY}</math></sub> = I <sub>X</sub> (fs) × I <sub>Y</sub> (fs)/(I <sub>Z</sub> × 2)
Full Scale Output (Differential)	(I <sub>XY</sub> - I <sub><math>\overline{XY}</math></sub> ) = I <sub>X</sub> (fs) × I <sub>Y</sub> (fs)/I <sub>Z</sub>
I <sub>Z</sub> (Bias) Input Voltage vs I <sub>Z</sub>	(See Figure 10)
I <sub>Z</sub> Signal Bandwidth vs I <sub>Z</sub>	(See Figure 11)
I <sub>X</sub> , I <sub>Y</sub> Signal Bandwidth vs I <sub>Z</sub>	(See Figure 6)
I <sub>X</sub> , I <sub>Y</sub> 1% Settling Time vs I <sub>Z</sub>	(See Figure 7)

# EL4083C

## Current Mode Four Quadrant Multiplier

### General Operating Information

— Contd.

rameters and, to some extent, bandwidth while improving the signal to noise performance, feedthrough and control range.

The EL4083 is fundamentally different from conventional voltage mode multipliers in that the available input range can be tailored to accommodate voltage sources of almost any size by selecting appropriate input series resistor values. If desired, one can interface with voltages that are much greater than the supplies from which the part is powered. Current source signals can be connected directly to the multiplier inputs. The parts' dynamic range can also be tailored to a large extent for a current signal by the appropriate selection of  $I_Z$ . These inputs act in the same manner as a virtual ground input of an operational amplifier and thus can serve as a summing node for any number of voltage and/or current signals. Outputs of components such as current output DACs, transconductance amplifiers and current conveyors can be directly connected to the inputs.

Ideally, a multiplier should give zero output if either one of its multiplying inputs is zero. A nonzero output under these conditions is caused by a combination of input and output referred offsets. An output referred offset can be thought of as a fixed value added to the output and thus only affects D.C. accuracy. An input referred offset at a multiplying input allows signal to feedthrough from the other multiplying input to the output(s). The EL4083 is trimmed during testing at Elantec for X and Y input referred offset for  $I_Z = 1.6$  mA. The internal trim networks provide a current to each input which nulls the feedthrough caused by internal device mismatches. These current values are ratioed to the value of  $I_Z$  so that the input referred nulls are largely maintained at different values of  $I_Z$ . However, there will be some mistracking in the trim networks so that the input referred null point will deviate away from zero at values of  $I_Z$  lower than 1.6 mA. Figure 9 shows optional external input and output referred offset trim networks which can be used as needed to improve performance.

As mentioned, the output referred offset only affects D.C. accuracy which may not be an issue in A.C. applications. In gain control applications one may only need to null feedthrough with respect to the gain control input.

In gain control (VCA) applications the X input should be used as the control input and the signal applied to the Y input since it has slightly higher bandwidth and better linearity and distortion performance.

### Current Outputs ( $I_{XY}$ , $I_{\overline{XY}}$ ), Feedthrough and Distortion

Another unique feature of the EL4083 is the differential ground referenced current output structure. These outputs can drive 50 $\Omega$  terminated lines and reactive loads such as transformers, baluns, and LC tank and filter circuits directly.\* Unlike low impedance follower buffers, these outputs do not interact with the load to produce ringing or instability. If a high level low impedance output is required, the outputs can be recovered differentially and converted to a single ended output with a fast op amp such as the EL2075 (see Figure 19). The outputs can also drive current input devices such as CMF amps, current conveyors and its own inputs directly by simple connection.

Figures 12 and 14 show the nulled gain and feedthrough characteristics of the  $I_{XY}$  and  $I_{\overline{XY}}$  outputs which are virtually identical and differ only in phase. Figure 12 is with the A.C. signal applied to the X input with Y used as the gain control and in Figure 14 these signals are reversed. Note that in both cases the signal feedthrough rolls up and peaks near the cutoff frequency. This is quite typical of the performance of all previous four quadrant multipliers. Figures 13 and 15 show the corresponding gain/feedthrough characteristics for the differentially recovered output signal  $I_{XY} - I_{\overline{XY}}$ . Note that in this case the peak feedthrough at high frequencies is lower by more than 40 dB.

\* See EL2082 Data Sheet—Receiver IF Amplifier (Figure 19). The EL2082 also has a current output.

# ***EL4083C***

## ***Current Mode Four Quadrant Multiplier***

### **General Operating Information**

— Contd.

Figures 16 and 17 show the total harmonic distortion for the single-ended and differential recovered outputs for a full scale A.C. input signal on one input and a full scale D.C. control signal on the other. Note that above about one megahertz to the cutoff frequency the THD of the differentially recovered signal is as much as 10 dB lower than the single-ended signals.

# EL4083C

## Current Mode Four Quadrant Multiplier

### General Operating Information — Contd.

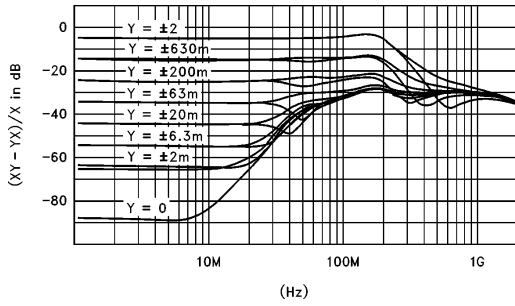

**Figure 12. Nulled  $I_{XY}$  and  $I_{\overline{XY}}$  Frequency Response (Signal on XIN, Gain Controlled by YIN)**

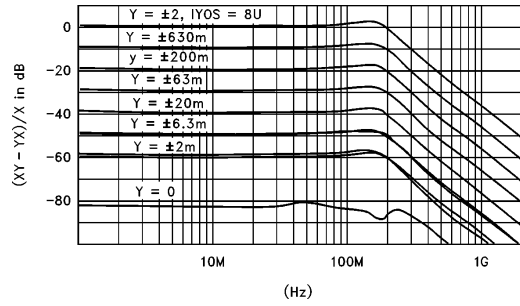

**Figure 13. Nulled  $(I_{XY} - I_{\overline{XY}})$  Frequency Response (Signal on XIN, Gain Controlled by YIN)**

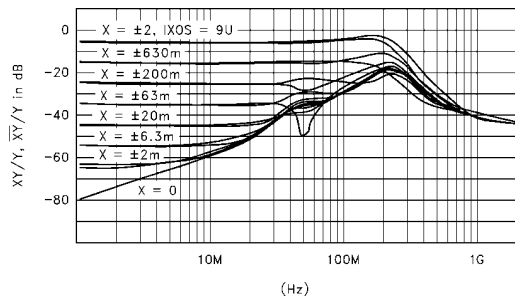

**Figure 14. Nulled  $I_{XY}$  and  $I_{\overline{XY}}$  Frequency Response (Signal on YIN, Gain Controlled by XIN)**

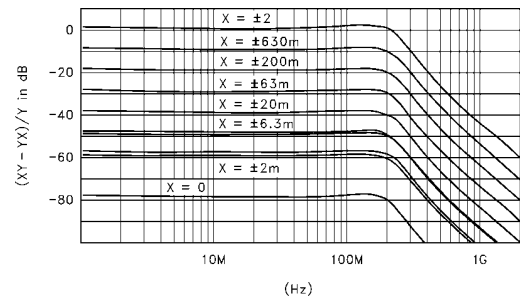

**Figure 15. Nulled  $(I_{XY} - I_{\overline{XY}})$  Frequency Response (Signal on YIN, Gain Controlled by XIN)**

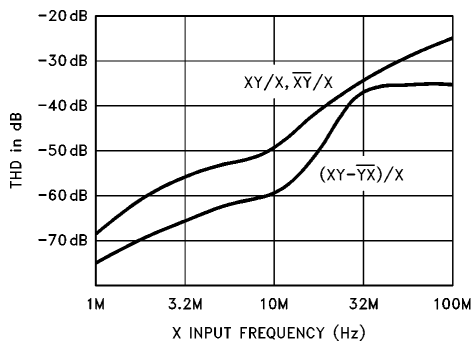

**Figure 16. (Full Level XIN THD vs Frequency)**

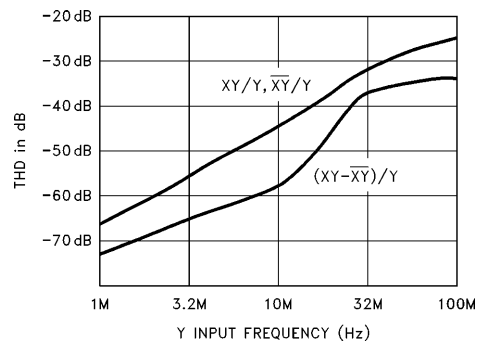

**Figure 17. (Full Level YIN THD vs Frequency)**

# ***EL4083C***

## ***Current Mode Four Quadrant Multiplier***

### **Applications**

#### **Basic Product Functions**

Figures 18 and 19 are the basic schematics for many of the applications of the EL4083. These can perform signal mixing, frequency doubling, modulation, demodulation, gain control/voltage-controlled amplification, multiplication and squaring. Figure 18 has resistively terminated differential outputs and has the widest bandwidth. The figure also shows the option of using the EL2260 dual CMF amplifier to recover the outputs differentially at very low impedance.

This has a maximum 3 dB bandwidth of 130 MHz and settles to 1% in 25 ns. Figure 19 uses an EL2075 at the outputs as a differential to single ended converter with gain to take advantage of the performance enhancements of the differentially recovered output mentioned above and to provide a high level low impedance drive. The  $-3$  dB bandwidth of this circuit is over 150 MHz using good layout techniques. However, to achieve this bandwidth one must restrict the output swing to little more than 1 V<sub>pp</sub> to avoid running into the 500V/ $\mu$ s minimum slew rate of the EL2075. Table 2 shows the input signal assignments for the applications listed above.

**Table 2. Input Signal Assignments for Figures 18 and 19 Circuits**

<b>Application</b>	<b>V<sub>X</sub></b>	<b>V<sub>Y</sub></b>
Mixer	Signal 1	Signal 2
Frequency Doubler	Signal	Signal
Modulator	Modulating Signal	Carrier
Demodulator	Local Oscillator	Modulated Signal
Gain Control/VCA	Gain Control	Signal
Multiplier	Signal 1	Signal 2
Squarer	Signal	Signal

\*X means not connected if function is not used.

# EL4083C

## Current Mode Four Quadrant Multiplier

### Applications — Contd.

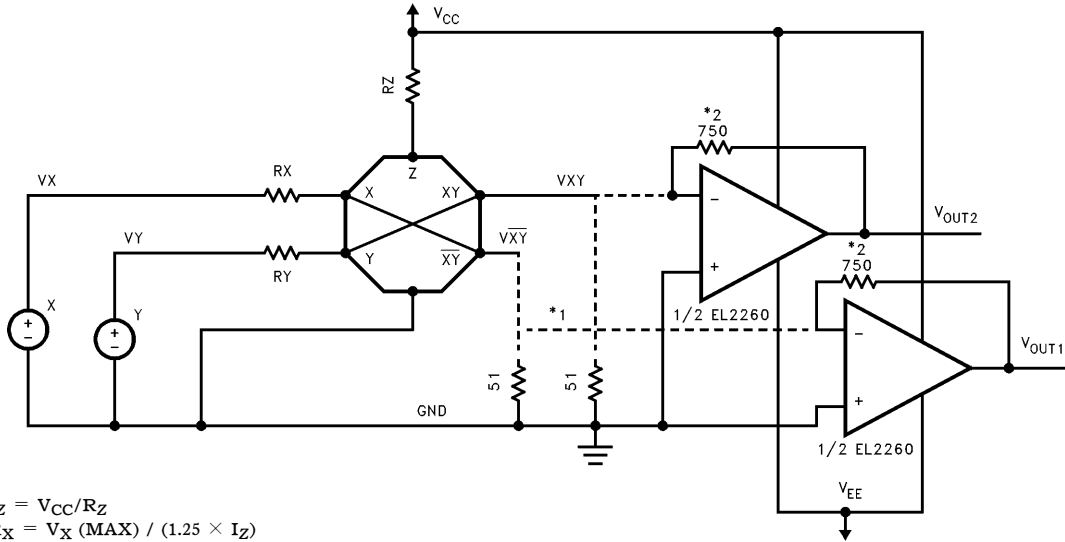

$I_Z = V_{CC}/R_Z$   
 $R_X = V_X(\text{MAX}) / (1.25 \times I_Z)$   
 $R_Y = V_Y(\text{MAX}) / (1.25 \times I_Z)$

- \*1. 51Ω Resistors omitted when using EL2260
- \*2. Optimum value of  $R_F$  determined by supplies and amount of tolerable peaking  
 (-3 dB BW ~ 90 MHz @  $V_S = \pm 5V$ , BW ~ 150 MHz @  $\pm 15V$ )

4083-27

**Figure 18. Basic Schematic (Dual Diff Outs)**

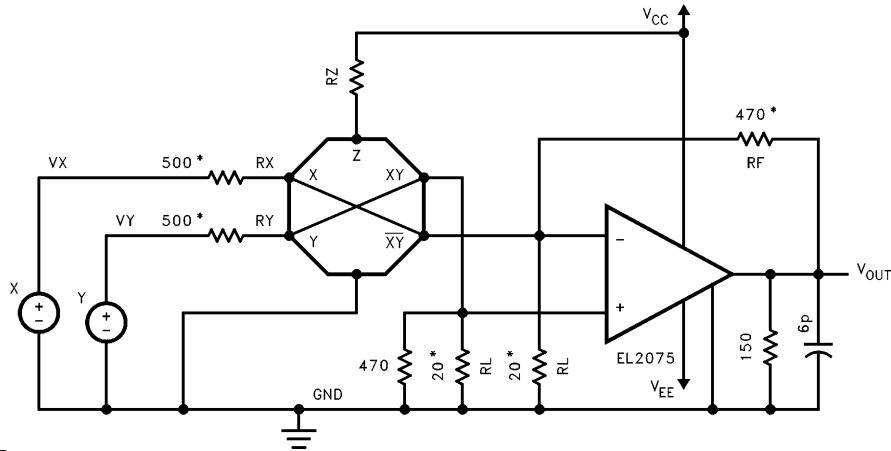

$I_Z = V_{CC}/R_Z$   
 $R_X = V_X(\text{MAX}) / (1.25 \times I_Z)$   
 $R_Y = V_Y(\text{MAX}) / (1.25 \times I_Z)$

- \*Optimized for Wide Bandwidth

4083-28

**Figure 19. Basic Schematic (Single Ended Converted)  
(150 MHz VCA)**

# EL4083C

## Current Mode Four Quadrant Multiplier

### Other Applications

Elantec has also published an applications note covering other applications of the EL4083. These include dividers, squaring and square rooting circuits, several RMS and power measurement circuits, and a wideband AGC circuit. Also presented are two polynomial computation examples for video and some HDTV quality fader and summing circuits. The EL4083 has been found flexible enough to easily implement all of the classic four quadrant multiplier applications and also offer interesting new applications possibilities.

### EL4083 Macromodel

This macromodel is compatible with PSPICE (copyrighted by Microsim Corporation). It has been designed to work accurately for fixed values of  $I_Z$  (bias) in the range of  $200 \mu\text{A}$  to  $1.6 \text{ mA}$ . The additional simulation burden imposed by including provision for a time varying  $I_Z$  was thought not worthwhile. The value of  $I_Z$  is specified to the model by the parameter NS. The relation be-

tween  $I_Z$  and NS is;  $I_Z = 200 \mu\text{A} \times \text{NS}$ . All other inputs can accept time varying signals.

The model will provide good transient and frequency response and settling time estimates as well as time domain switching results. Input and output impedance and overload responses are correctly modeled. The D.C. current drawn from supplies for a given value of  $I_Z$  is also correct.

Noise, PSRR and the temperature dependence of A.C. parameters such as frequency response and settling time are not modeled. Linearity and distortion results from the model will be worse than the real part by about a factor of three and do not show the correct frequency dependence.

The macromodel is constructed from simple controlled sources, passive components and stripped transistor and diode models. As such it should be usable, perhaps with slight modification, on all but student or demonstration simulators where the model's size may be a problem.

### Macromodel

\*EL4083 Macromodel

\*Revision A, August 22, 1994

\*

\*Connection: IZ(BIAS)

```
*      | IX(in)
*      | | IY(in)
*      | | | VEE
*      | | | | VCC
*      | | | | | IXY
*      | | | | | | /IXY
*      | | | | | | |
```

.subckt EL4083 ZIN XIN YIN VEE VCC IXY IYX

.MODEL M1MP5DIODE D TT=60p IS=1f CJO=300f  
VJ=600m XTI=3 EG=1.11 RS=80m

.MODEL M2MDCAP D TT=100n IS=2e-17 CJO=1p  
VJ=800m RS=300

.MODEL M3MNP1 NPN CJC=1.3p TF=120p IS=1.04f  
BF=120 CJS=480f

.MODEL M4MPNP1 PNP CJC=1.79p TF=50.166666666667p  
IS=1f BF=90 CJS=480f

C1 N9 N7 9p

C2 N7 0 350f

C3 N19 N16 9p

C4 N16 0 350f

```
D1 0 N15 M2MDCAP 12
D10 0 N26 M1MP5DIODE 1
D11 N26 N27 M1MP5DIODE 1
D12 N29 N30 M1MP5DIODE 1
D13 0 N31 M1MP5DIODE 1
D14 VBP N34 M1MP5DIODE 2
D15 N34 VBP M1MP5DIODE 2
D16 0 N34 M2MDCAP 12.5
D17 N35 0 M2MDCAP 12.5
D18 N35 VBN M1MP5DIODE 2
D19 VBN N35 M1MP5DIODE 2
D2 N15 0 M2MDCAP 12
D20 N42 N10 M2MDCAP 4
D21 N10 0 M2MDCAP 4
D22 0 N20 M2MDCAP 4
D23 N20 N45 M2MDCAP 4
D3 0 N12 M1MP5DIODE 8
D4 N55 N13 M1MP5DIODE 8
D5 0 N25 M2MDCAP 6
D6 N25 0 M2MDCAP 6
D7 0 N22 M1MP5DIODE 8
D8 N54 N23 M1MP5DIODE 8
D9 0 N28 M1MP5DIODE 1
EV94 0 VBN 0 N45 1
```

# EL4083C

## Current Mode Four Quadrant Multiplier

### Macromodel — Contd.

```

EV95 VBP 0 N42 0 1
EV96 N54 0 N21 0 650m
EV97 N55 0 N11 0 650m
EV98 N27 0 N28 0 1
EV99 N29 0 SWIN 0 1
FI10 VN-VEE VFI10 1
FI11 VCC VP-VFI11 1
FI12 VCC N39 VFI12 1
FI13 N37 VEE VFI13 1
FI14 VCC N38 VFI14 1
FI15 N36 VEE VFI15 1
FI16 N45 VEE VFI16 1
FI17 VCC N42 VFI17 1
FI18 N37 N36 VFI18 500m
FI19 N38 N39 VFI19 500m
FI20 VN+ VN- VFI20 500m
FI21 VP+ VP- VFI21 500m
FI22 0 N21 VFI22 1
FI23 N21 0 VFI23 1
FI24 N24 0 VFI24 2
FI25 N14 0 VFI25 2
FI26 N11 0 VFI26 1
FI27 0 N11 VFI27 1
FI28 VCC VEE VFI28 21
FI 29 N28 ZB1 VFI29 1
FI5 N33 0 VFI5 1
FI6 0 N33 VFI6 1
FI7 N35 N34 VFI7 1
FI8 VN+ VEE VFI8 1
FI9 VCC VP+ VFI9 1
IIBGN 0 VEE 2.2m
IIBGP VCC 0 2.46m
IISWB N32 VEE 629u
IISWI SWIN VEE 555u
IIZSU N28 VEE 10u
L1 N7 IXA 71n
L2 XIN N7 4n
L3 N16 IYA 71n
L4 YIN N16 4n
L5 N46 IYX 4n
L6 N47 IXY 4n
Q10 N10 VP+ [VEE] M4MPNP1 2
Q10 N46 VN+ N36[VEE] M3MNP1 2
Q11 N47 VN+ N37 [VEE] M3MNP1 2
Q12 N46 VN- N37 [VEE] M3MNP1 2
Q13 0 N34 N56 [VEE] M4MPNP1 400m
Q14 0 N34 N57 [VEE] M4MPNP1 400m
Q15 0 N35 N58 [VEE] M3MNP1 400m
Q16 0 N35 N59 [VEE] M3MNP1 400m
Q2 0 N10 VP- [VEE] M4MPNP1 2
Q3 0 N20 VN+ [VEE] M3MNP1 2
Q4 0 N20 VN- [VEE] M3MNP1 2
Q5 N46 VP- N39 [VEE] M4MPNP1 2
Q6 N47 VP+ N39 [VEE] M4MPNP1 2
Q7 N46 VP+ N38 [VEE] M4MPNP1 2
Q8 N47 VP- N38 [VEE] M4MPNP1 2
Q9 N47 VN- N36 [VEE] M3MNP1 2
R1 N15 N7 60 TC=824u 7.67u
R10 N16 N17 450 TC=0 0
R11 YIN N16 100 TC=0 0
R12 0 SWIN 500 TC=824u 7.67u
R13 N56 N38 35 TC=0 0
R14 N57 N39 35 TC=0 0
R15 N37 N58 35 TC=0 0
R16 N36 N59 35 TC=0 0
R17 N46 IYX 100 TC=0 0
R18 N47 IXY 100 TC=0 0
R2 N11 IXC 6.25 TC=0 0
R3 N9 IXC 4.5 TC=0 0
R4 N7 IXA 1.5K TC=0 0
R5 XIN N7 100 TC=0 0
R6 N25 N16 156 TC=824u 7.67u
R7 N21 IYC 6.25 TC=0 0
R8 ITC N19 45 TC=0 0
R9 N17 IYA 45 TC=0 0
RSU VEE 0 16K TC=0 0
VFI10 N43 N44 0.0
VFI11 N40 N41 0.0
VFI12 ZB4 ZB5 0.0
VFI13 ZB5 ZB6 0.0
VFI14 ZB3 ZB4 0.0
VFI15 ZB6 ZB7 0.0
VFI16 N44 ZB9 0.0
VFI17 N41 ZB8 0.0
VFI18 IYB IYC 0.0
VFI19 IYA IYB 0.0
VFI20 IXB IXC 0.0
VFI21 IXA IXB 0.0
VFI22 N22 N24 0.0
VFI23 N23 N24 0.0
VFI24 ZB2 ZB3 0.0
VFI25 ZB1 ZB2 0.0
VFI26 N13 N14 0.0
VFI27 N12 N14 0.0
VFI28 ZB9 VEE 0.0
VFI29 ZIN N26 0.0
VF15 N30 N32 0.0
VF16 N31 N32 0.0
VF17 N33 0 0.0
VF18 ZB8 N43 0.0
VF19 ZB7 N40 0.0
.ENDS

```

# ***EL4083C***

## ***Current Mode Four Quadrant Multiplier***

### **General Disclaimer**

Specifications contained in this data sheet are in effect as of the publication date shown. Elantec, Inc. reserves the right to make changes in the circuitry or specifications contained herein at any time without notice. Elantec, Inc. assumes no responsibility for the use of any circuits described herein and makes no representations that they are free from patent infringement.

***élantec***  
HIGH PERFORMANCE ANALOG INTEGRATED CIRCUITS

### **Elantec, Inc.**

1996 Tarob Court

Milpitas, CA 95035

Telephone: (408) 945-1323

(800) 333-6314

Fax: (408) 945-9305

European Office: 44-71-482-4596

### **WARNING — Life Support Policy**

Elantec, Inc. products are not authorized for and should not be used within Life Support Systems without the specific written consent of Elantec, Inc. Life Support systems are equipment intended to support or sustain life and whose failure to perform when properly used in accordance with instructions provided can be reasonably expected to result in significant personal injury or death. Users contemplating application of Elantec, Inc. products in Life Support Systems are requested to contact Elantec, Inc. factory headquarters to establish suitable terms & conditions for these applications. Elantec, Inc.'s warranty is limited to replacement of defective components and does not cover injury to persons or property or other consequential damages.



LittleDiode supplies new, hard to find or obsolete electronic components and semiconductors all over the world.

With over two million different components listed you are sure to find the part you need.

Feel free to visit us today at our online store:

[LittleDiode.com](http://LittleDiode.com)

Looking forward to providing you with the best possible service.