

Features

- Full function video fader
- 0.02%/0.02° differential gain/phase @ 100% gain
- 25 ns multiplexer included
- Output amplifier included
- Calibrated linear gain control
- ± 5V to ± 15V operation
- 60 MHz bandwidth
- Low thermal errors

Applications

- Video faders/wipers
- Gain control
- Graphics overlay
- Video text insertion
- Level adjust
- Modulation

Ordering Information

Part No.	Temp. Range	Package	Outline #
EL4095CN	-40°C to +85°C	14 Pin P-DIP	MDP0031
EL4095CS	-40°C to +85°C	SO-14	MDP0027

General Description

The EL4095C is a versatile variable-gain building block. At its core is a fader which can variably blend two inputs together and an output amplifier that can drive heavy loads. Each input appears as the input of a current-feedback amplifier and with external resistors can separately provide any gain desired. The output is defined as:

$$V_{OUT} = A \cdot V_{INA} (0.5V + V_{GAIN}) + B \cdot V_{INB} (0.5V - V_{GAIN}),$$

where A and B are the fed-back gains of each channel.

Additionally, two logic inputs are provided which each override the analog V_{GAIN} control and force 100% gain for one input and 0% for the other. The logic inputs switch in only 25 ns and provide high attenuation to the off channel, while generating very small glitches.

Signal bandwidth is 60 MHz, and gain-control bandwidth 20 MHz. The gain control recovers from overdrive in only 70 ns.

The EL4095C operates from ± 5V to ± 15V power supplies, and is available in both 14-pin DIP and narrow surface mount packages.

Connection Diagram

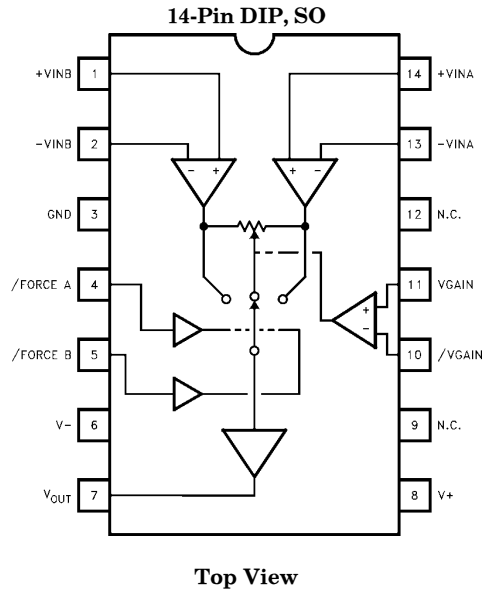

Manufactured under U.S. Patent No. 5,321,371, 5,374,898

Note: All information contained in this data sheet has been carefully checked and is believed to be accurate as of the date of publication; however, this data sheet cannot be a "controlled document". Current revisions, if any, to these specifications are maintained at the factory and are available upon your request. We recommend checking the revision level before finalization of your design documentation.

EL4095C

Video Gain Control/Fader/Multiplexer

Absolute Maximum Ratings ($T_A = 25^\circ\text{C}$)

V_{S+}	Supply Voltage	+18V	V_{FORCE}	Input Voltage	-1V to +6V
V_S	Voltage between V_{S+} and V_{S-}	+33V	I_{OUT}	Output Current	± 35 mA
$+V_{\text{INA}}, +V_{\text{INB}}$	Input Voltage	(V_{S-}) -0.3V to (V_{S+}) +0.3V	T_A	Operating Temperature Range	-40°C to +85°C
I_{IN}	Current Into $-V_{\text{INA}}, -V_{\text{INB}}$	5 mA	T_J	Operating Junction Temperature	0°C to +150°C
V_{GAIN}	Input Voltage	$V_{\text{GAIN}} \pm 5V$	T_{ST}	Storage Temperature Range	-65°C to +150°C
V_{GAIN}	Input Voltage	V_{S-} to V_{S+}		Internal Power Dissipation	See Curves

Important Note:

All parameters having Min/Max specifications are guaranteed. The Test Level column indicates the specific device testing actually performed during production and Quality inspection. Elantec performs most electrical tests using modern high-speed automatic test equipment, specifically the LTX77 Series system. Unless otherwise noted, all tests are pulsed tests, therefore $T_J = T_C = T_A$.

Test Level	Test Procedure
I	100% production tested and QA sample tested per QA test plan QCX0002.
II	100% production tested at $T_A = 25^\circ\text{C}$ and QA sample tested at $T_A = 25^\circ\text{C}$, T_{MAX} and T_{MIN} per QA test plan QCX0002.
III	QA sample tested per QA test plan QCX0002.
IV	Parameter is guaranteed (but not tested) by Design and Characterization Data.
V	Parameter is typical value at $T_A = 25^\circ\text{C}$ for information purposes only.

Open Loop DC Electrical Characteristics

$V_S = \pm 15V$, $T_A = 25^\circ\text{C}$, V_{GAIN} ground unless otherwise specified

Parameter	Description	Limits			Test Level	Units
		Min	Typ	Max		
V_{OS}	Input Offset Voltage		1.5	5	I	mV
$I_{\text{B+}}$	+ V_{IN} Input Bias Current		5	10	I	μA
$I_{\text{B-}}$	- V_{IN} Input Bias Current		10	50	I	μA
CMRR	Common Mode Rejection	65	80		I	dB
-CMRR	- V_{IN} Input Bias Current Common Mode Rejection		0.5	1.5	I	$\mu\text{A}/V$
PSRR	Power Supply Rejection Ratio	65	95		I	dB
-IPSR	- V_{IN} Input Current Power Supply Rejection Ratio		0.2	2	I	$\mu\text{A}/V$
R_{OL}	Transimpedance	0.2	0.4		I	$\text{M}\Omega$
$R_{\text{IN-}}$	- V_{IN} Input Resistance		80		V	Ω
V_{IN}	+ V_{IN} Range	(V_{-}) + 3.5		(V_{+}) - 3.5	I	V
V_{O}	Output Voltage Swing	(V_{-}) + 2		(V_{+}) - 2	I	V
I_{SC}	Output Short-Circuit Current	80	125	160	I	mA
V_{IH}	Input High Threshold at Force A or Force B Inputs			2.0	I	V
V_{IL}	Input Low Threshold at Force A or Force B Inputs	0.8			I	V
$I_{\text{FORCE, High}}$	Input Current of Force A or Force B, $V_{\text{FORCE}} = 5V$			-50	I	μA
$I_{\text{FORCE, Low}}$	Input Current of Force A or Force B, $V_{\text{FORCE}} = 0V$		-440	-650	I	μA

EL4095C

Video Gain Control/Fader/Multiplexer

Open Loop DC Electrical Characteristics — Contd.

$V_S = \pm 15V$, $T_A = 25^\circ C$, unless otherwise specified

Parameter	Description	Limits			Test Level	Units
		Min	Typ	Max		
Feedthrough, Forced	Feedthrough of Deselected Input to Output, Deselected Input at 100% Gain Control	60	75		I	dB
$V_{GAIN, 100\%}$	Minimum Voltage at V_{GAIN} for 100% Gain	0.45	0.5	0.55	I	V
$V_{GAIN, 0\%}$	Maximum Voltage at V_{GAIN} for 0% Gain	-0.55	-0.5	-0.45	I	V
NL, Gain	Gain Control Non-linearity, $V_{IN} = \pm 0.5V$		2	4	I	%
$R_{IN, VG}$	Impedance between V_{GAIN} and $\overline{V_{GAIN}}$	4.5	5.5	6.5	I	k Ω
NL, $A_V = 1$	Signal Non-linearity, $V_{IN} = \pm 1V$, $V_{GAIN} = 0.55V$ Signal Non-linearity, $V_{IN} = \pm 1V$, $V_{GAIN} = 0V$ Signal Non-linearity, $V_{IN} = \pm 1V$, $V_{GAIN} = -0.25V$		<0.01		V	%
$A_V = 0.5$			0.03		V	%
$A_V = 0.25$			0.07	0.4	I	%
I_S	Supply Current		17	21	I	mA

Closed Loop AC Electrical Characteristics

$V_S = \pm 15V$, $A_V = +1$, $R_F = R_{IN} = 1 k\Omega$, $R_L = 500\Omega$, $C_L = 15 pF$, $C_{IN-} = 2 pF$, $T_A = 25^\circ C$, $A_V = 100\%$ unless otherwise noted

Parameter	Description	Limits			Test Level	Units
		Min	Typ	Max		
SR	Slew Rate; V_{OUT} from -3V to +3V Measured at -2V and +2V		330		V	V/ μs
BW	Bandwidth		60 30 6		V	MHz MHz MHz
dG	Differential Gain; AC Amplitude of 286 mV _{p-p} at 3.58 MHz on DC Offset of -0.7V, 0V and +0.7V $A_V = 100\%$ $A_V = 50\%$ $A_V = 25\%$		0.02 0.07 0.07		V	% % %
d θ	Differential Phase; AC Amplitude of 286 mV _{p-p} at 3.58 MHz on DC Offset of -0.7V, 0V and +0.7V $A_V = 100\%$ $A_V = 50\%$ $A_V = 25\%$		0.02 0.05 0.15		V	° ° °
T_S	Settling Time to 0.2%; V_{OUT} from -2V to +2V $A_V = 100\%$ $A_V = 25\%$		100 100		V	ns ns
T_{FORCE}	Propagation Delay from $V_{FORCE} = 1.4V$ to 50% Output Signal Enabled or Disabled Amplitude		25		V	ns
BW, Gain	-3 dB Gain Control Bandwidth, V_{GAIN} Amplitude 0.5 V _{p-p}		20		V	MHz
$T_{REC, Gain}$	Gain Control Recovery from Overload; V_{GAIN} from -0.7V to 0V		70		V	ns

EL4095C

Video Gain Control/Fader/Multiplexer

Typical Performance Curves

Large-Signal Pulse
Response Gain = +1

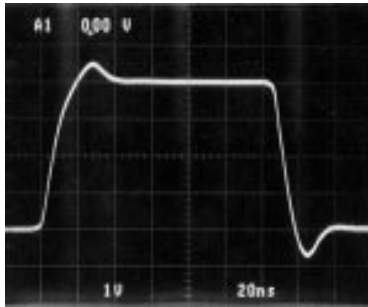

4095-6

Large-Signal Pulse
Response Gain = -1

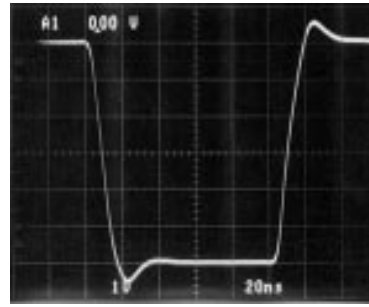

4095-7

Small-Signal Pulse Response
for Various Gains

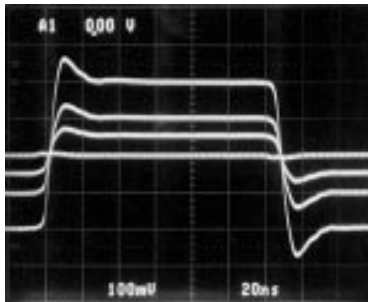

4095-8

Frequency Response for Different
Gains $A_V = +1$

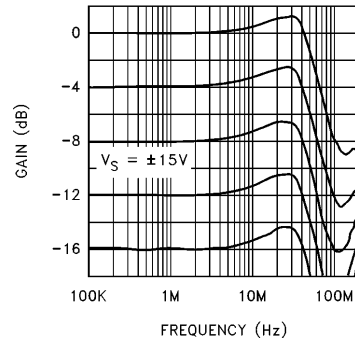

4095-9

Frequency Response with Different
Values of R_F - Gain = +1

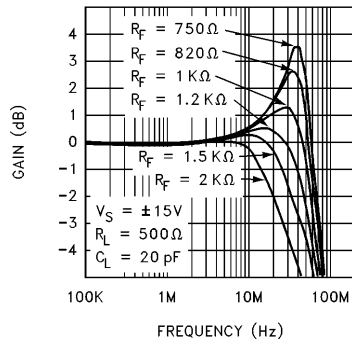

4095-10

Frequency Response with Different
Values of R_F - Gain = -1

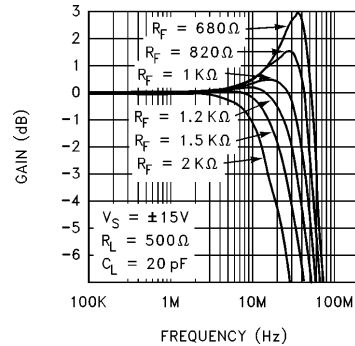

4095-11

EL4095C

Video Gain Control/Fader/Multiplexer

Typical Performance Curves — Contd.

Frequency Response with Different Gains

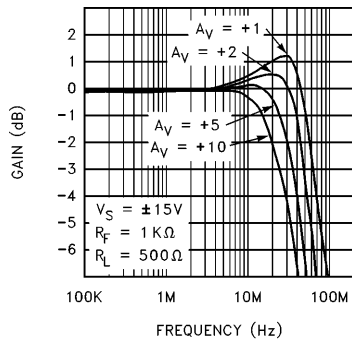

Frequency Response with Various Load Capacitances and Resistances

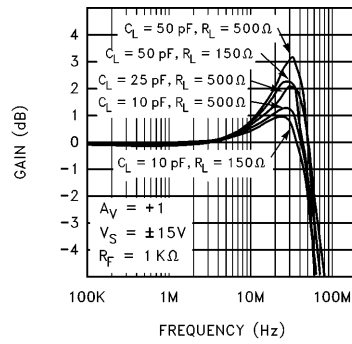

Frequency Response with Various Values of Parasitic C_{IN-}

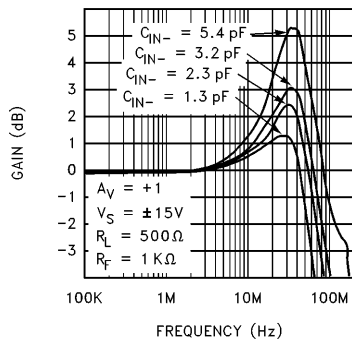

Input Noise Voltage and Current vs Frequency

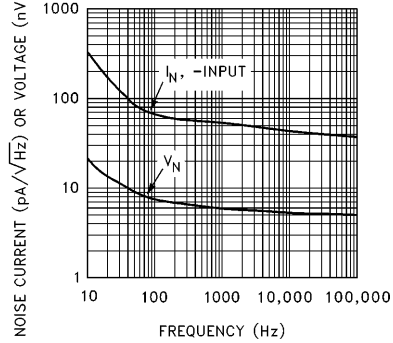

Change in Bandwidth and Slewrate with Supply Voltage - Gain = +1

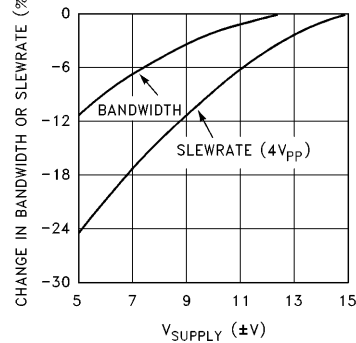

Change in Bandwidth and Slewrate with Supply Voltage - Gain = -1

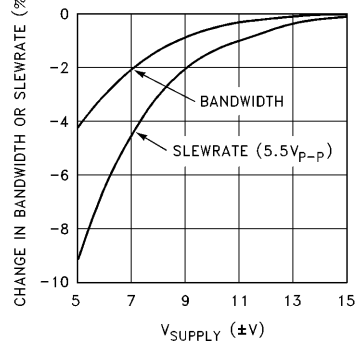

4095-12

EL4095C

Video Gain Control/Fader/Multiplexer

Typical Performance Curves — Contd.

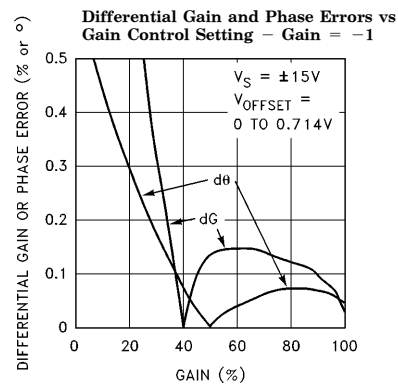
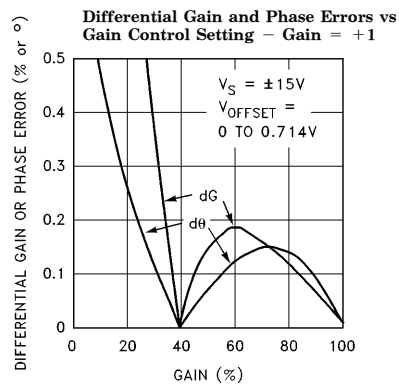
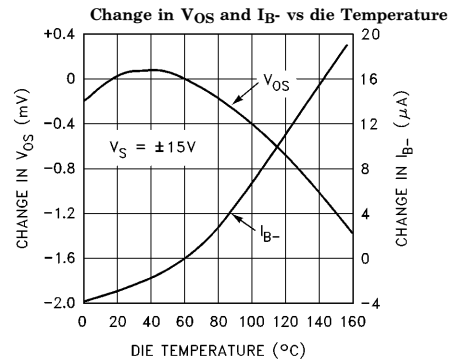
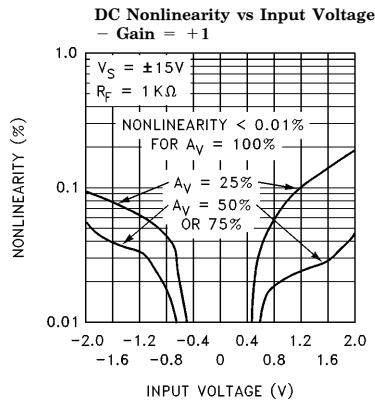
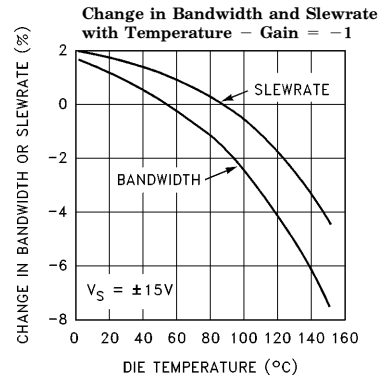
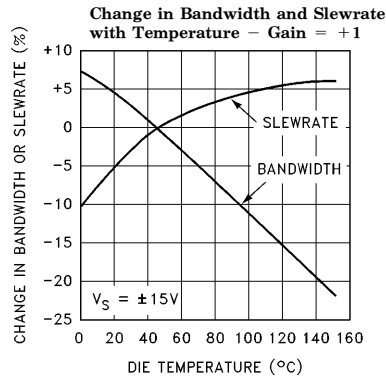

4095-13

EL4095C

Video Gain Control/Fader/Multiplexer

Typical Performance Curves — Contd.

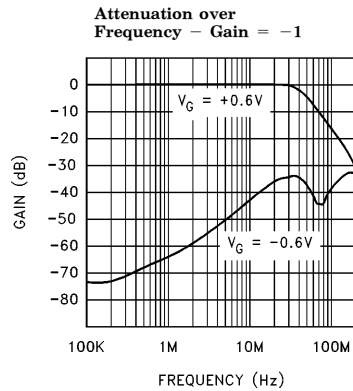
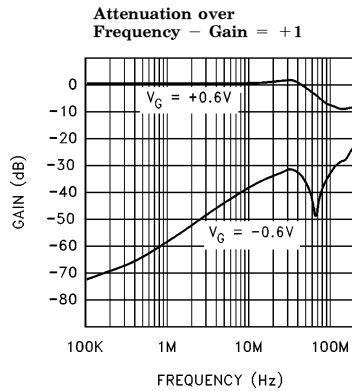
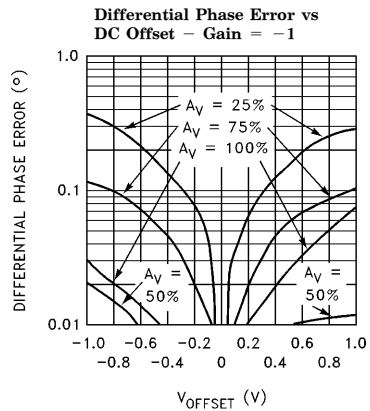
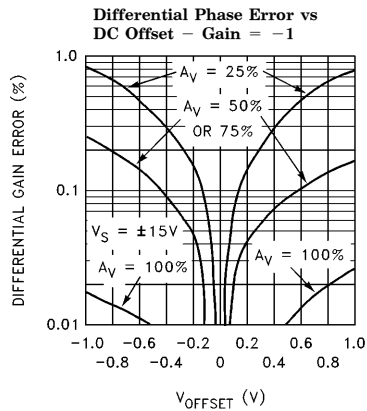
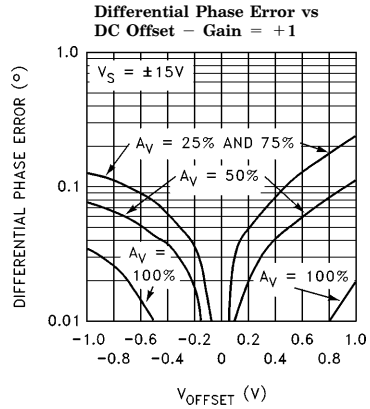
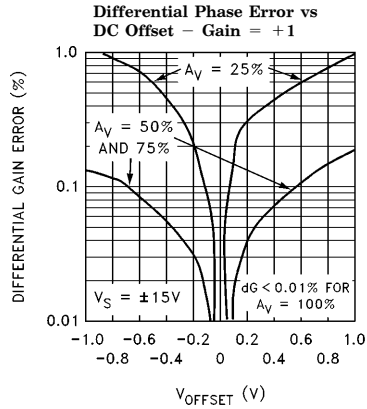

4095-14

EL4095C

Video Gain Control/Fader/Multiplexer

Typical Performance Curves — Contd.

Gain vs V_G (1 V_{DC} at V_{INA})

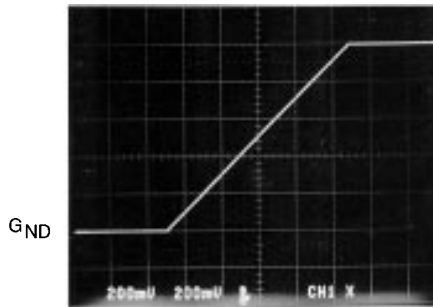

4095-15

Gain Control Gain vs Frequency

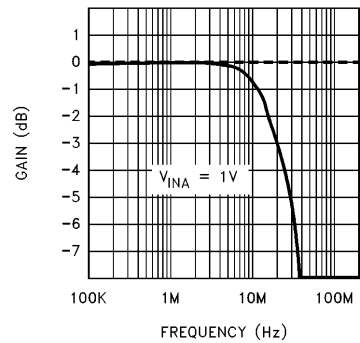

4095-16

Gain Control Response to a Non-Overloading Step, Constant Sinewave at V_{INA}

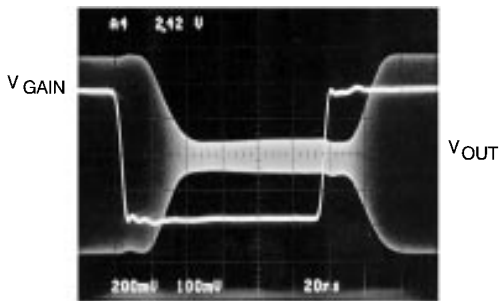

4095-17

V_{GAIN} Overload Recovery Delay

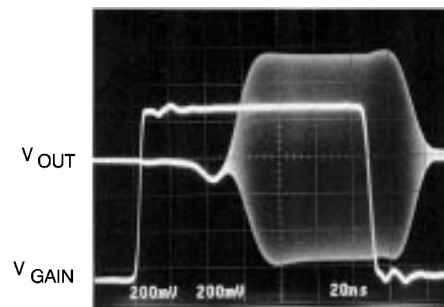

4095-18

V_{GAIN} Overload Recovery Response—No AC Input



4095-19

Cross-Fade Balance -0V on A_{IN} and B_{IN} ; Gain = +1

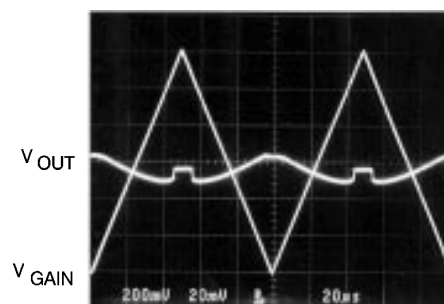

4095-20

EL4095C

Video Gain Control/Fader/Multiplexer

Typical Performance Curves — Contd.

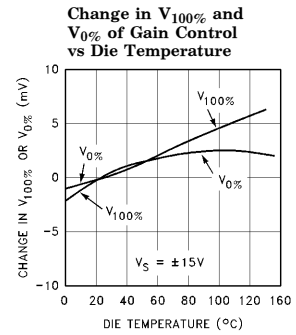
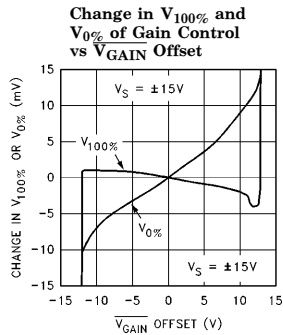
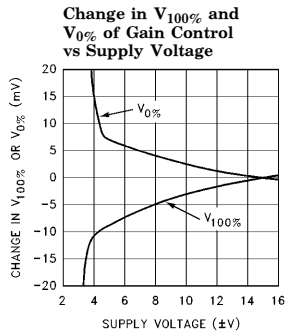

4095-21

Force Response

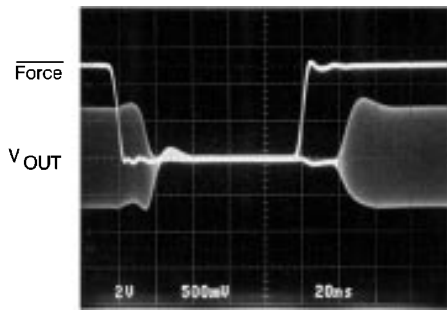

4095-22

Force-Induced Output Transient

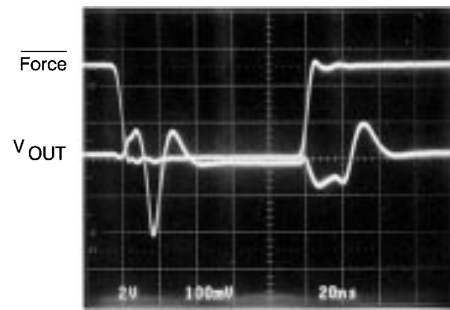

4095-23

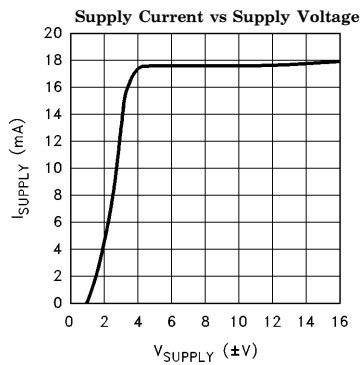

4095-24

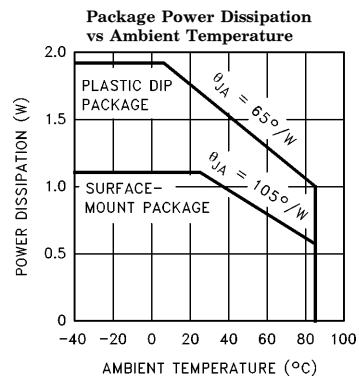

4095-25

EL4095C

Video Gain Control/Fader/Multiplexer

Test Circuit, $A_V = +1$

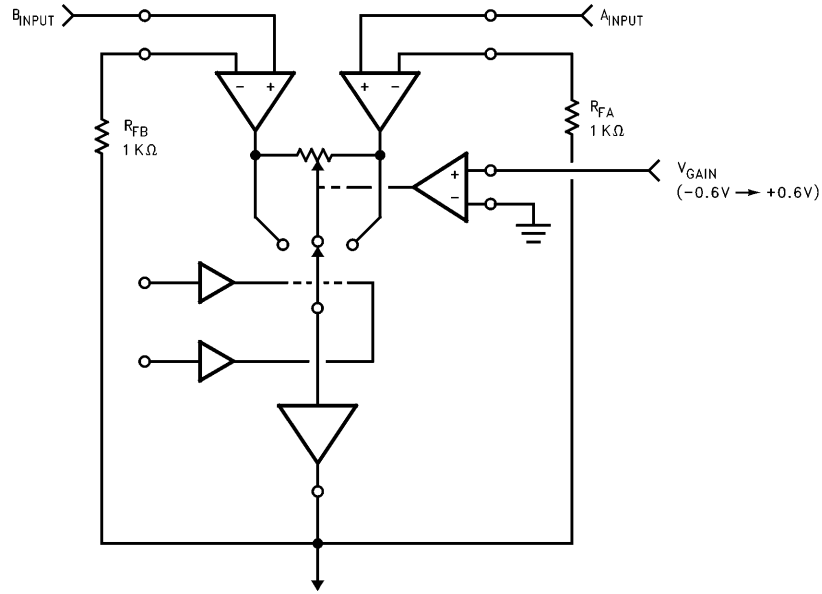

$$\begin{aligned} \text{OUTPUT} &= A_{IN} (0.5 + V_{GAIN}) + B_{IN} (0.5 - V_{GAIN}) \\ &\text{FOR } -0.5V \leq V_{GAIN} \leq +0.5V \end{aligned}$$

4095-26

EL4095C

Video Gain Control/Fader/Multiplexer

Applications Information

The EL4095 is a general-purpose two-channel fader whose input channels each act as a current-feedback amplifier (CFA) input. Each input can have its own gain factor as established by external resistors. For instance, the Test Circuit shows two channels each arranged as +1 gain, with the traditional single feedback resistor R_F connected from V_{OUT} to the $-V_{IN}$ of each channel.

The EL4095 can be connected as an inverting amplifier in the same manner as any CFA:

Frequency Response

Like other CFA's, there is a recommended feedback resistor, which for this circuit is $1\text{ K}\Omega$. The value of R_F sets the closed-loop -3 dB bandwidth, and has only a small range of practical variation. The user should consult the typical performance curves to find the optional value of R_F for a given circuit gain. In general, the bandwidth will decrease slightly as closed-loop gain is increased; R_F can be reduced to make up for bandwidth loss. Too small a value of R_F will cause frequency response peaking and ringing during transients. On the other hand, increasing R_F will reduce bandwidth but improve stability.

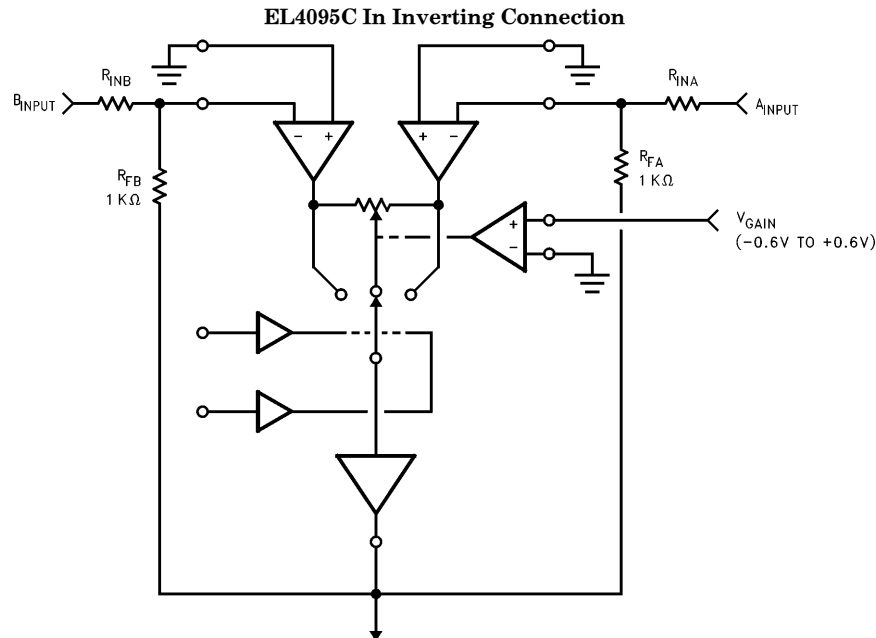

$$\begin{aligned} \text{OUTPUT} &= -A_{IN} \left(\frac{R_{FA}}{R_{INA}} \right) (0.5 + V_{GAIN}) \\ &\quad - B_{IN} \left(\frac{R_{FB}}{R_{INB}} \right) (0.5 - V_{GAIN}) \\ &\text{FOR } -0.5V \leq V_{GAIN} \leq +0.5V \end{aligned}$$

4095-27

EL4095C

Video Gain Control/Fader/Multiplexer

Applications Information — Contd.

Stray capacitance at each $-V_{IN}$ terminal should absolutely be minimized, especially in a positive-gain mode, or peaking will occur. Similarly, the load capacitance should be minimized. If more than 25 pF of load capacitance must be driven, a load resistor from 100Ω to 400Ω can be added in parallel with the output to reduce peaking, but some bandwidth degradation may occur. A “snubber” load can alternatively be used. This is a resistor in series with a capacitor to ground, 150Ω and 100 pF being typical values. The advantage of a snubber is that it does not draw DC load current. A small series resistor, low tens of ohms, can also be used to isolate reactive loads.

Distortion

The signal voltage range of the $+V_{IN}$ terminals is within 3.5V of either supply rail.

One must also consider the range of error currents that will be handled by the $-V_{IN}$ terminals. Since the $-V_{IN}$ of a CFA is the output of a buffer which replicates the voltage at $+V_{IN}$, error currents will flow into the $-V_{IN}$ terminal. When an input channel has 100% gain assigned to it, only a small error current flows into its negative input; when low gain is assigned to the channel the output does not respond to the channel's signal and large error currents flow.

Here are a few idealized examples, based on a gain of +1 for channels A and B and $R_F = 1\text{ k}\Omega$ for different gain settings:

Gain	V_{INA}	V_{INB}	$I(-V_{INA})$	$I(-V_{INB})$	V_{OUT}
100%	1V	0	0	1 mA	1V
75%	1V	0	-250 μA	750 μA	0.75V
50%	1V	0	-500 μA	500 μA	0.5V
25%	1V	0	-750 μA	250 μA	0.25V
0%	1V	0	-1 mA	0	0V

Thus, either $-V_{IN}$ can receive up to 1 mA error current for 1V of input signal and 1 kΩ feedback resistors. The maximum error current is 3 mA for the EL4095, but 2 mA is more realistic. The major contributor of distortion is the magnitude of error currents, even more important than loading effects. The performance curves show distortion versus input amplitude for different gains.

If maximum bandwidth is not required, distortion can be reduced greatly (and signal voltage range enlarged) by increasing the value of R_F and any associated gain-setting resistor.

100% Accuracies

When a channel gain is set to 100%, static and gain errors are similar to those of a simple CFA. The DC output error is expressed by

$$V_{OUT, \text{ Offset}} = V_{OS} * A_V + (I_{B-}) * R_F.$$

The input offset voltage scales with feedback gain, but the bias current into the negative input, I_{B-} , adds an error not dependent on gain. Generally, I_{B-} dominates up to gains of about seven.

The fractional gain error is given by

$$E_{GAIN} = (R_F + A_V * R_{IN-}) R_F / (A_V R_{IN-}) / R_{OL}$$

The gain error is about 0.3% for a gain of one, and increases only slowly for increasing gain. R_{IN-} is the input impedance of the input stage buffer, and R_{OL} is the transimpedance of the amplifier, 80 kΩ and 350 kΩ respectively.

Gain Control Inputs

The gain control inputs are differential and may be biased at any voltage as long as V_{GAIN} is less than 2.5V below $V+$ and 3V above $V-$. The differential input impedance is 5.5 kΩ, and a common-mode impedance is more than 500 kΩ. With zero differential voltage on the gain inputs, both signal inputs have a 50% gain factor. Nominal calibration sets the 100% gain of V_{INA} input at +0.5V of gain control voltage, and 0% at -0.5V of gain control. V_{INB} 's gain is complementary to that of V_{INA} ; +0.5V of gain control sets 0% gain at V_{INB} and -0.5V gain control sets 100% V_{INB} gain. The gain control does not have a completely abrupt transition at the 0% and 100% points. There is about 10 mV of “soft” transfer at the gain endpoints. To obtain the most accurate 100% gain factor or best attenuation of 0% gain, it is necessary to overdrive the gain control input by about 30 mV. This would set the gain control voltage range as -0.565 mV to +0.565V, or 30 mV beyond the maximum guaranteed 0% to 100% range.

Applications Information — Contd.

In fact, the gain control internal circuitry is very complex. Here is a representation of the terminals:

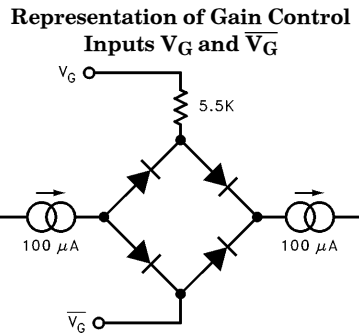

For gain control inputs between $\pm 0.5V$ ($\pm 90 \mu A$), the diode bridge is a low impedance and all of the current into V_G flows back out through $\overline{V_G}$. When gain control inputs exceed this amount, the bridge becomes a high impedance as some of the diodes shut off, and the V_G impedance rises sharply from the nominal $5.5 K\Omega$ to over $500 K\Omega$. This is the condition of gain control overdrive. The actual circuit produces a much sharper overdrive characteristics than does the simple diode bridge of this representation.

The gain input has a 20 MHz -3 dB bandwidth and 17 ns risetime for inputs to $\pm 0.45V$. When the gain control voltage exceeds the 0% or 100% values, a 70 ns overdrive recovery transient will occur when it is brought back to linear range. If quicker gain overdrive response is required, the Force control inputs of the EL4095 can be used.

Force Inputs

The Force inputs completely override the V_{GAIN} setting and establish maximum attainable 0% and 100% gains for the two input channels. They are activated by a TTL logic low on either of the \overline{FORCE} pins, and perform the analog switching very quickly and cleanly. \overline{FORCEA} causes 100% gain on the A channel and 0% on the B channel. \overline{FORCEB} does the reverse, but there is no defined output state when \overline{FORCEA} and \overline{FORCEB} are simultaneously asserted.

The Force inputs do not incur recovery time penalties, and make ideal multiplexing controls. A typical use would be text overlay, where the A channel is a video input and the B channel is digitally created text data. The \overline{FORCEA} input is set low normally to pass the video signal, but released to display overlay data. The gain control can be used to set the intensity of the digital overlay.

Other Applications Circuits

The EL4095 can also be used as a variable-gain single input amplifier. If a 0% lower gain extreme is required, one channel's input should simply be grounded. Feedback resistors must be connected to both $-V_{IN}$ terminals; the EL4095 will not give the expected gain range when a channel is left unconnected.

This circuit gives $+0.5$ to $+2.0$ gain range, and is useful as a signal leveller, where a constant output level is regulated from a range of input amplitudes:

EL4095C

Video Gain Control/Fader/Multiplexer

Application Information — Contd.

Although another amplifier is needed to gain the output back to standard level, the reduced error currents bring the differential phase error to less than 0.1° over the entire input range.

A useful technique to reduce video distortion is to DC-restore the video level going into the EL4095, and offsetting black level to -0.35V so that the entire video span encompasses $\pm 0.35\text{V}$ rather

than the unrestored possible span of $\pm 0.7\text{V}$ (for standard-sized signals). For the preceding leveler circuit, the black level should be set more toward -0.7V to accommodate the largest input, or made to vary with the gain control itself (large gain, small offset; small gain, larger offset).

The EL4095 can be wired as a four quadrant multiplier:

EL4095 Connected as a Four-Quadrant Multiplier

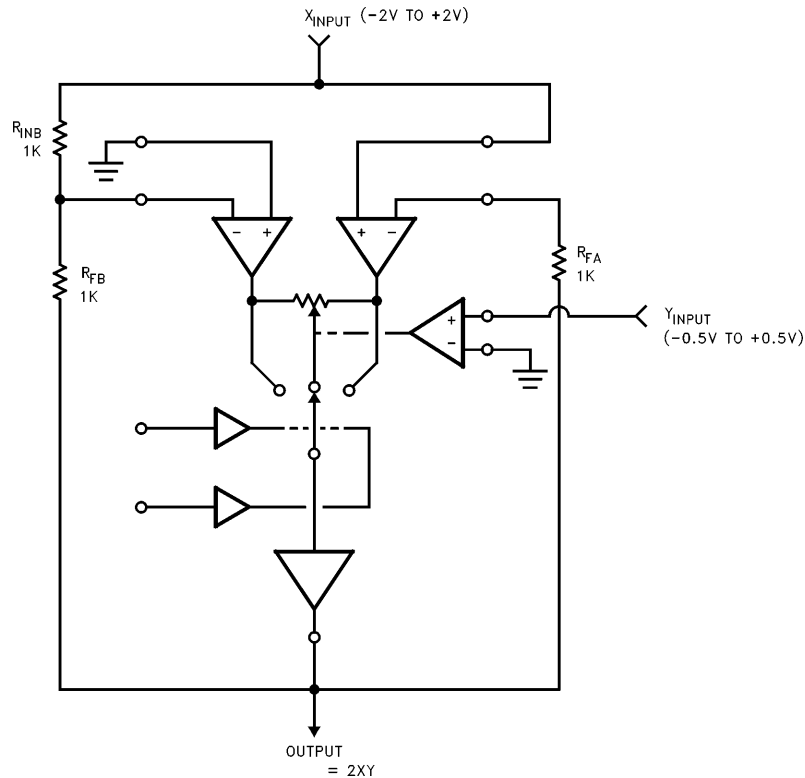

4095-32

EL4095C

Video Gain Control/Fader/Multiplexer

Application Information — Contd.

The A channel gains the input by +1 and the B channel by -1. Feedthrough suppression of the Y input can be optimized by introducing an offset between channel A and B. This is easily done by injecting an adjustable current into the summing junction ($-V_{IN}$ terminal) of the B input channel.

The two input channels can be connected to a common input through two dissimilar filters to create a DC-controlled variable filter. This circuit provides a controlled range of peaking through rolloff characteristics:

Variable Peaking Filter

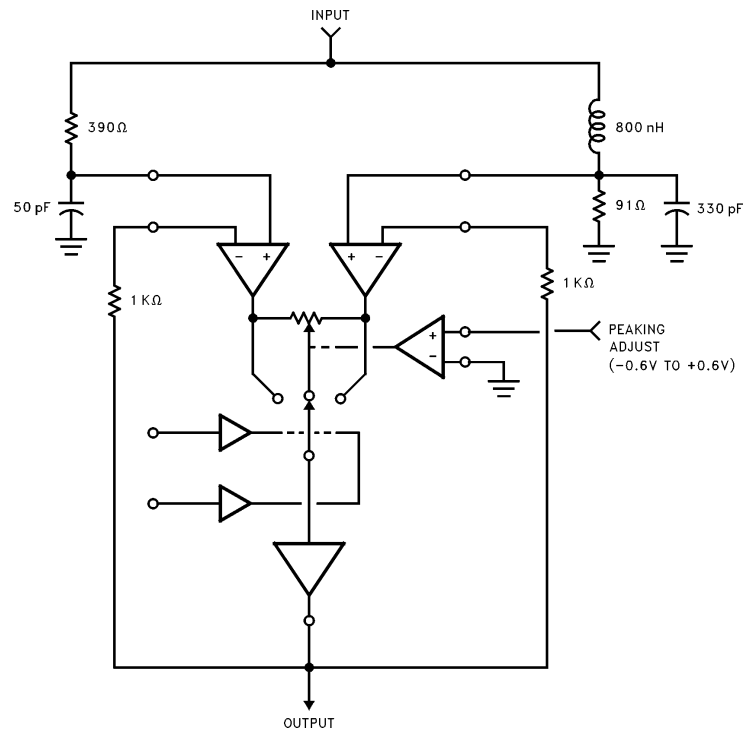

4095-33

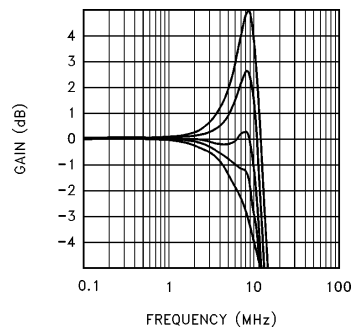

4095-34

EL4095C

Video Gain Control/Fader/Multiplexer

Applications Information — Contd.

The EL4095 is connected as a unity-gain fader, with an LRC peaking network connected to the A-input and an RC rolloff network connected to the B-input. The plot shows the range of peaking controlled by the V_{GAIN} input. This circuit would be useful for flattening the frequency response of a system, or for providing equalization ahead of a lossy transmission line.

Noise

The electrical noise of the EL4095 has two components: the voltage noise in series with $+V_{IN}$ is $5 \text{ nV} \sqrt{\text{Hz}}$ wideband, and there is a current noise injected into $-V_{IN}$ of $35 \text{ pA} \sqrt{\text{Hz}}$. The output noise will be

$$\overline{V}_{n, \text{out}} = \sqrt{(A_V \cdot \overline{V}_{n, \text{input}})^2 + (\overline{I}_{n, \text{input}} \cdot R_F)^2},$$

and the input-referred noise is

$$\overline{V}_{n, \text{input-referred}} = \sqrt{(\overline{V}_{n, \text{input}})^2 + (\overline{I}_{n, \text{input}} \cdot R_F / A_V)^2}$$

where A_V is the fed-back gain of the EL4095. Here is a plot of input-referred noise vs A_V :

Input-Referred Noise vs Closed-Loop Gain

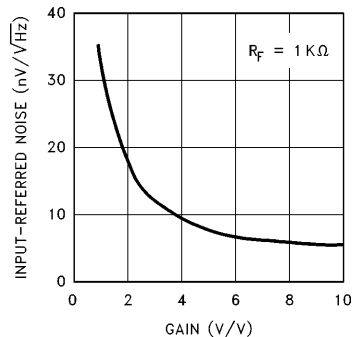

Thus, for a gain of three or more the fader has a noise as good as an op-amp. The only trade-off is that the dynamic range of the input is reduced by the gain due to the nonlinearity caused by gained-up output signals.

Power Dissipation

Peak die temperature must not exceed 150°C . This allows 75°C internal temperature rise for a 75°C ambient. The EL4095 in the 14-pin PDIP

package has a thermal resistance of $65^\circ\text{C}/\text{W}$, and can thus dissipate 1.15W at a 75°C ambient temperature. The device draws 20 mA maximum supply current, only 600 mW at $\pm 15\text{V}$ supplies, and the circuit has no dissipation problems in this package.

The SO-14 surface-mount package has a $105^\circ\text{C}/\text{W}$ thermal resistance with the EL4095, and only 714 mW can be dissipated at 75°C ambient temperature. The EL4095 thus can be operated with $\pm 15\text{V}$ supplies at 75°C , but additional dissipation caused by heavy loads must be considered. If this is a problem, the supplies should be reduced to $\pm 5\text{V}$ to $\pm 12\text{V}$ levels.

The output will survive momentary short-circuits to ground, but the large available current will overheat the die and also potentially destroy the circuit's metal traces. The EL4095 is reliable within its maximum average output currents and operating temperatures.

EL4095C Macromodel

This macromodel is offered to allow simulation of general EL4095 behavior. We have included these characteristics:

Small-signal frequency response	Signal path DC distortions
Output loading effects	V_{GAIN} I-V characteristics
Input impedance	V_{GAIN} overdrive recovery delay
Off-channel feedthrough	100% gain error
Output impedance over frequency	FORCE operation
$-V_{IN}$ characteristics and sensitivity to parasitic capacitance	

These will give a good range of results of various operating conditions, but the macromodel does not behave identically as the circuit in these areas:

Temperature effects	Manufacturing tolerances
Signal overload effects	Supply voltage effects
Signal and $\overline{V_G}$ operating range	Slewrate limitations
Current-limit	Noise
Video and high-frequency distortions	Power supply interactions
Glitch and delay from FORCE inputs	

EL4095C

Video Gain Control/Fader/Multiplexer

EL4095C Macromodel — Contd.

```
D4 205 5 Dclamp
.model Dclamp D (TT=200n)
Vttl 206 0 2.4
V1 115 0 4999.3
V2 0 116 4999.3
V3 113 117 0.5
V4 119 118 0.5
V5 203 115 0.7
V6 116 202 0.7
G10 114 0 11 10 -0.001
G11 11 10 114 0 -2E-8
E10 117 0 201 0 1E-4
E11 118 0 201 0 -1E-4
S1 114 200 5 0 Nopen
S2 200 201 4 0 Nopen
S3 203 201 4 0 Nclosed
S4 202 201 5 0 Nclosed
.model Nopen VSWITCH (Ron=100 Roff=1E12 Von=1.6 Voff=1.2)
.model Nclosed VSWITCH ( Ron=100 Roff=1E12 Von=1.2 Voff=1.6)
***
.ENDS
*****
```

4095-37

EL4095C

Video Gain Control/Fader/Multiplexer

EL4095C Macromodel — Contd.

The EL4095 Macromodel Schematic

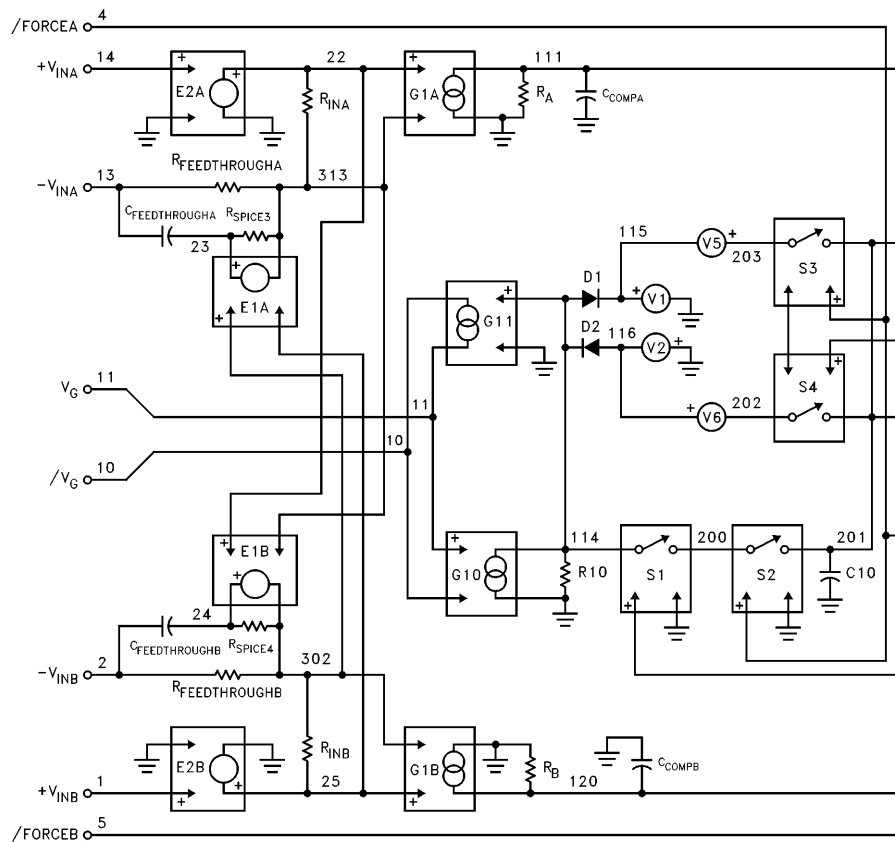

4095-38

EL4095C

Video Gain Control/Fader/Multiplexer

EL4095C Macromodel — Contd.

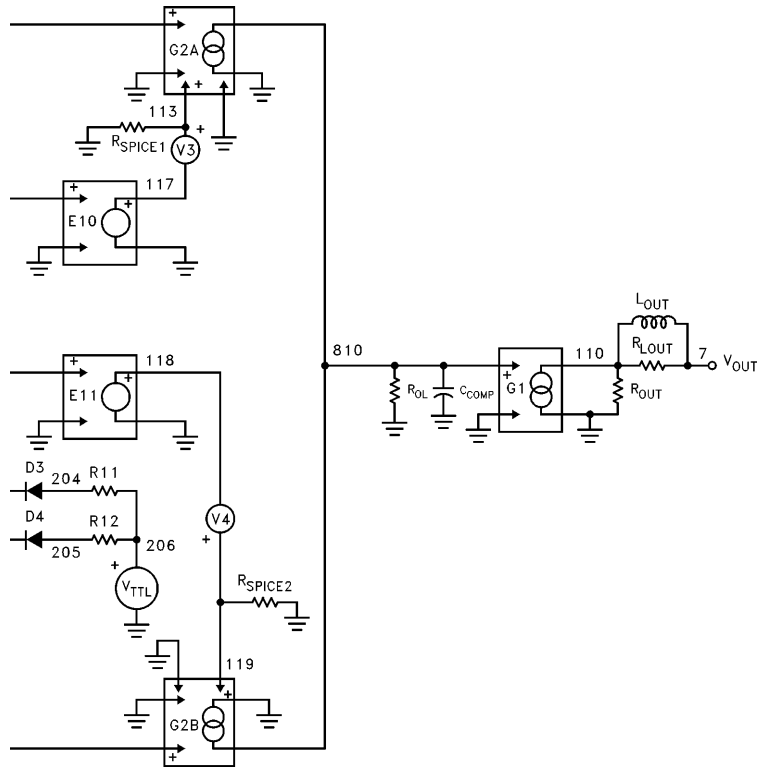

4095-39

BLANK

EL4095C

Video Gain Control/Fader/Multiplexer

General Disclaimer

Specifications contained in this data sheet are in effect as of the publication date shown. Elantec, Inc. reserves the right to make changes in the circuitry or specifications contained herein at any time without notice. Elantec, Inc. assumes no responsibility for the use of any circuits described herein and makes no representations that they are free from patent infringement.

élantec
HIGH PERFORMANCE ANALOG INTEGRATED CIRCUITS

Elantec, Inc.

1996 Tarob Court

Milpitas, CA 95035

Telephone: (408) 945-1323

(800) 333-6314

Fax: (408) 945-9305

European Office: 44-71-482-4596

WARNING — Life Support Policy

Elantec, Inc. products are not authorized for and should not be used within Life Support Systems without the specific written consent of Elantec, Inc. Life Support systems are equipment intended to support or sustain life and whose failure to perform when properly used in accordance with instructions provided can be reasonably expected to result in significant personal injury or death. Users contemplating application of Elantec, Inc. products in Life Support Systems are requested to contact Elantec, Inc. factory headquarters to establish suitable terms & conditions for these applications. Elantec, Inc.'s warranty is limited to replacement of defective components and does not cover injury to persons or property or other consequential damages.



LittleDiode supplies new, hard to find or obsolete electronic components and semiconductors all over the world.

With over two million different components listed you are sure to find the part you need.

Feel free to visit us today at our online store:

LittleDiode.com

Looking forward to providing you with the best possible service.