

May 27, 1999

TEL:805-498-2111 FAX:805-498-3804 WEB:http://www.semtech.com

DESCRIPTION

The EZ1900 is a high performance positive load current balancer designed for use in applications utilizing 2 regulators in parallel to achieve equal current sharing or identical current for each load. The regulator balance controller allows a flexible motherboard design to be made to cope with different processor configurations. The controller reads a logic level upgrade signal (denoted V_{CC2DET} on the Intel P55C; similar on AMD, Cyrix and PowerPC microprocessors) to control the output voltage of two linear low dropout voltage regulators to the CPU core and I/O planes. In single-voltage plane configurations (V_{CC2DET} floating), both regulators are set to the same output voltage (usually 3.3 - 3.5V) and are configured in master-slave mode. For split plane processors (V_{CC2DET} low), the outputs of the two regulators are switched - the core voltage will be set to a nominal 2.5V while the I/O voltage will remain at 3.3V. The actual output voltages can be adjusted by means of resistors. The EZ1900 programmable current balancer is available in the popular SO-8 surface mount package.

PIN CONFIGURATION

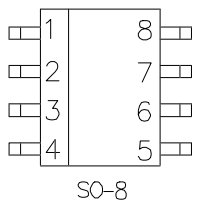

Pin #	Legend	Description
1	Sel	Non-slave mode, voltage select
2	-IN	Negative error amplifier input
3	+IN	Positive error amplifier input
4	-V	Power input, common
5	nc	No Connection
6	S _{OUT}	Sets V _{OUT} of slave device
7	+V	Power input, positive
8	nc	No connection

Slave Mode Pin: For non "Computer Select Operation", the Select Mode, pin #1, can be left open circuited for continuous slave mode operation or balance current control. Ground the Select Mode, pin #1, for non-slave mode operation.

FEATURES

- Current balance controller for regulators in parallel
- Slave and non-slave voltage modes
- Slave or non-slave mode computer selected
- Compatible with 3 or 5 pin low drop regulators
- Remote sense operation
- SO-8 package

APPLICATIONS

- Flexible upgrade from single voltage plane to split-plane processors
- Intel Pentium® Processor P54CS & P55C upgrades
- PowerPC™ 603 & 604 upgrades
- AMD5_x86™ upgrades

ORDERING INFORMATION

DEVICE ⁽¹⁾	PACKAGE
EZ1900CS	SO-8

Note:

(1) Add suffix 'TR' for tape and reel.

ABSOLUTE MAXIMUM RATINGS

Parameter	Symbol	Maximum	Units
Input Voltage Supply	V _{IN}	7	V
Differential Amplifier	-IN, +IN S _{OUT}	7 0 to +V	V
Slave Output Current (sink only)	I _{SLAVE}	50	mA
Thermal Resistance Junction to Ambient	θ _{JA}	160	°C/W
Operating Junction Temperature Range	T _J	0 to 70	°C
Storage Temperature Range	T _{STG}	-65 to 125	°C
Lead Temperature (Soldering) 5 Sec	T _{LEAD}	260	°C

May 27, 1999

ELECTRICAL CHARACTERISTICS

 Unless otherwise specified: $V_{IN} = 5V$; $I_{SLAVE} = 10mA$; $T_J = 25^{\circ}C$.

Parameter	Symbol	Test Conditions			Test Limits			Units
		+V	S _{OUT}	T _J	Min	Typ	Max	
Input								
Input Error Voltage	V _{IO}						5	mV
Common Mode Input Range	V _{CM}	7V			1		7	V
Average Temperature Coefficient, Input DIFF Voltage	$\frac{\Delta V_{IE}}{\Delta T}$					0.01		mV/°C
Input Current	I _{IC}					50	200	nA
Common Mode Rejection Ratio	CMRR	7V			70	80		dB
Power Supply Rejection Ration	PSRR				60	70		dB
Sensitivity	$\Delta I_{OUT} / \Delta V_{DIFF}$				10	50		ϕ
Select Threshold Low High	V _{TH}				2.4		0.8	V
Select Input Current Low SEL = 0V	I _{SEL}					-150	-200	μA
High SEL = 7V							1	
Output								
Slave Output Leakage	S _{OL}		7V				1	μA
Slave Output Resistance	R _O				2	3	4	Ω
Power Supply Current Slave Mode	I _{CC}					500	700	μA
Non-Slave Mode						3	5	mA
Off Mode								700

May 27, 1999

V_{OUT}/RESISTOR SELECTION REFERENCE

(Resistor selection in Ω. See Typical Applications on following pages.)

Slave Mode (Master Regulator) V_M

V _{OUT}	R3	R4	Calc V _{OUT}
3.500	130	232	3.494
3.300	115	187	3.293
2.900	133	174	2.895
2.800	137	169	2.801
2.700	137	158	2.700
2.600	121	130	2.600
2.500	115	115	2.506

Non-Slave Mode (Slave Regulator) V_S

V _{OUT}	R1	R2	*Calc V _{OUT}
3.500	137	243	3.508
3.300	137	221	3.306
2.900	137	178	2.911
2.800	124	150	2.801
2.700	130	147	2.701
2.600	121	127	2.600
2.500	133	137	2.498

Notes:

$$V_M = V_{REF} (1 + R4 / R3) + I_{ADJ} R4.$$
 Resistor selection is based upon standard table for 1% resistors.

Notes:

$$V_S = V_{REF} (1 + (R2 + 3\Omega) / R1) + I_{ADJ} (R2 + 3\Omega).$$
 *The EZ1900 operating in the non-slave mode operation will introduce approximately 3 ohms of resistance in the voltage set path when selected. The calculated values are based upon this addition.

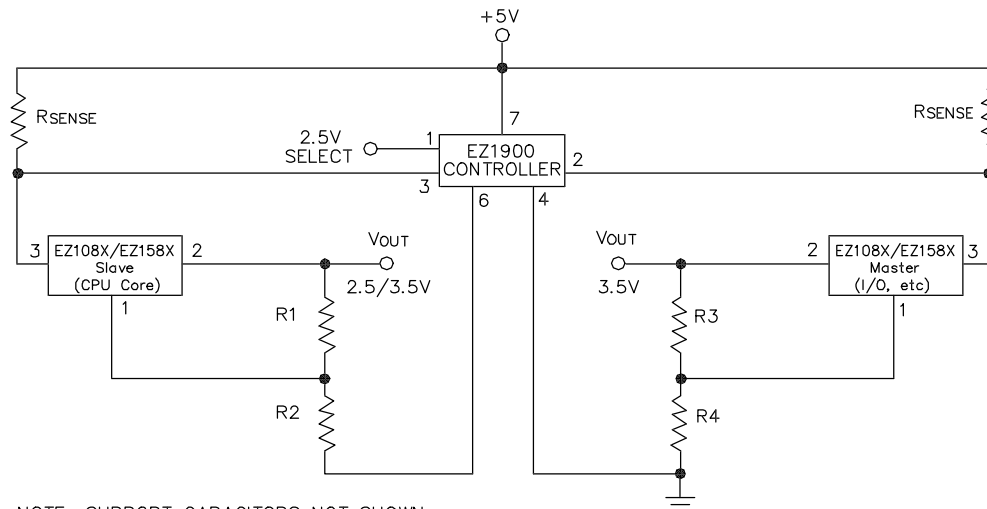
TYPICAL APPLICATIONS
Balanced Current Controller Utilizing EZ108X/EZ158X Series

NOTE: SUPPORT CAPACITORS NOT SHOWN.

Voltage Select

 Slave Mode Operation $V_M = V_{OUT}$ of Master
 $V_M = V_{REF} (1 + R4/R3) + I_{ADJ} R4$
 Non-Slave Mode, $V_S = V_{OUT}$ of Slave
 $V_S = V_{REF} (1 + (R2 + 3\Omega) / R1) + I_{ADJ} (R2 + 3\Omega)$
R_{SENSE} Select

 R_{SENSE} Select; Typical selection can be
 $(50mV \text{ to } 100mV) / (\text{Total } I_{OUT} / 2).$
 Trace resistance of 10mΩ and above can easily accommodate value required.

May 27, 1999

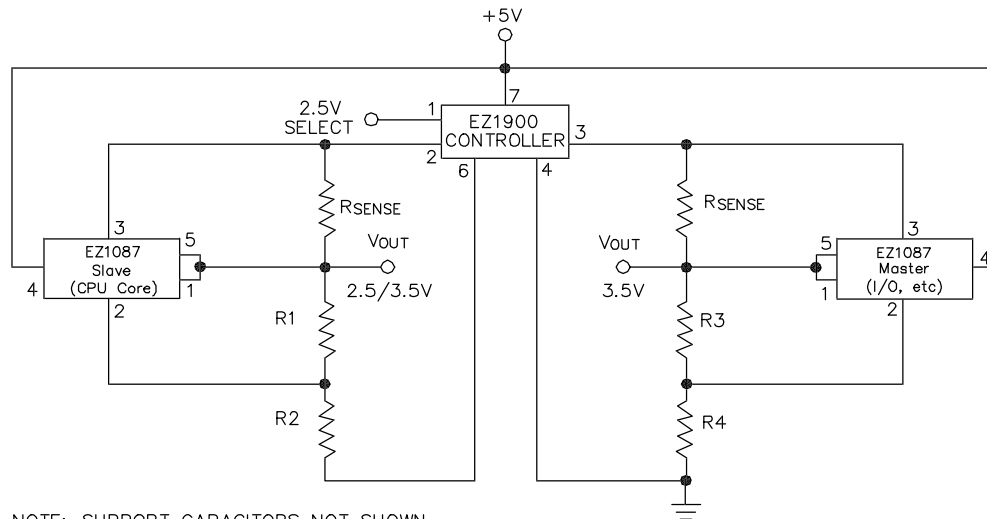
TYPICAL APPLICATIONS (cont.)
Balanced Current Controller Utilizing EZ1087 Series

NOTE: SUPPORT CAPACITORS NOT SHOWN.

Voltage Select

 Slave Mode Operation $V_M = V_{OUT}$ of Master

$$V_M = V_{REF} (1 + R4/R3) + I_{ADJ} R4$$

 Non-Slave Mode, $V_S = V_{OUT}$ of Slave

$$V_S = V_{REF} (1 + (R2 + 3\Omega) / R1) + I_{ADJ} (R2 + 3\Omega)$$

 R_{SENSE} Select
 R_{SENSE} Select; Typical selection can be

$$(50\text{mV to } 100\text{mV}) / (\text{Total } I_{OUT} / 2).$$

 Trace resistance of $10\text{m}\Omega$ and above can easily accommodate value required.

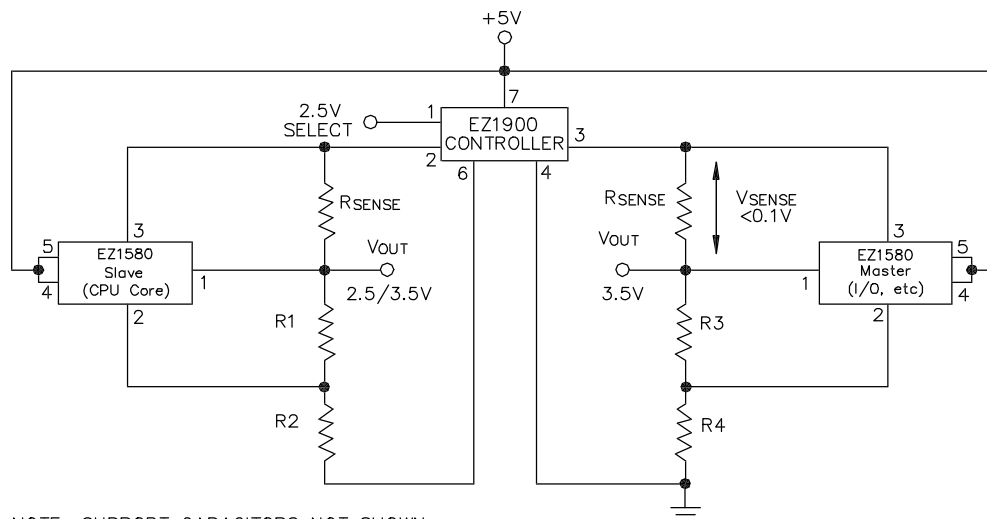
Balanced Current Controller Utilizing EZ1580 Series

NOTE: SUPPORT CAPACITORS NOT SHOWN.

Voltage Select

 Slave Mode Operation $V_M = V_{OUT}$ of Master

$$V_M = V_{REF} (1 + R4/R3) + I_{ADJ} R4$$

 Non-Slave Mode, $V_S = V_{OUT}$ of Slave

$$V_S = V_{REF} (1 + (R2 + 3\Omega) / R1) + I_{ADJ} (R2 + 3\Omega)$$

 R_{SENSE} Select
 R_{SENSE} Select (100mV Min) / (Total I_{OUT} / 2)

 The EZ1580 series requires R_{SENSE} voltage to be less than 100mV.

Trace resistance can easily accommodate value required.

May 27, 1999

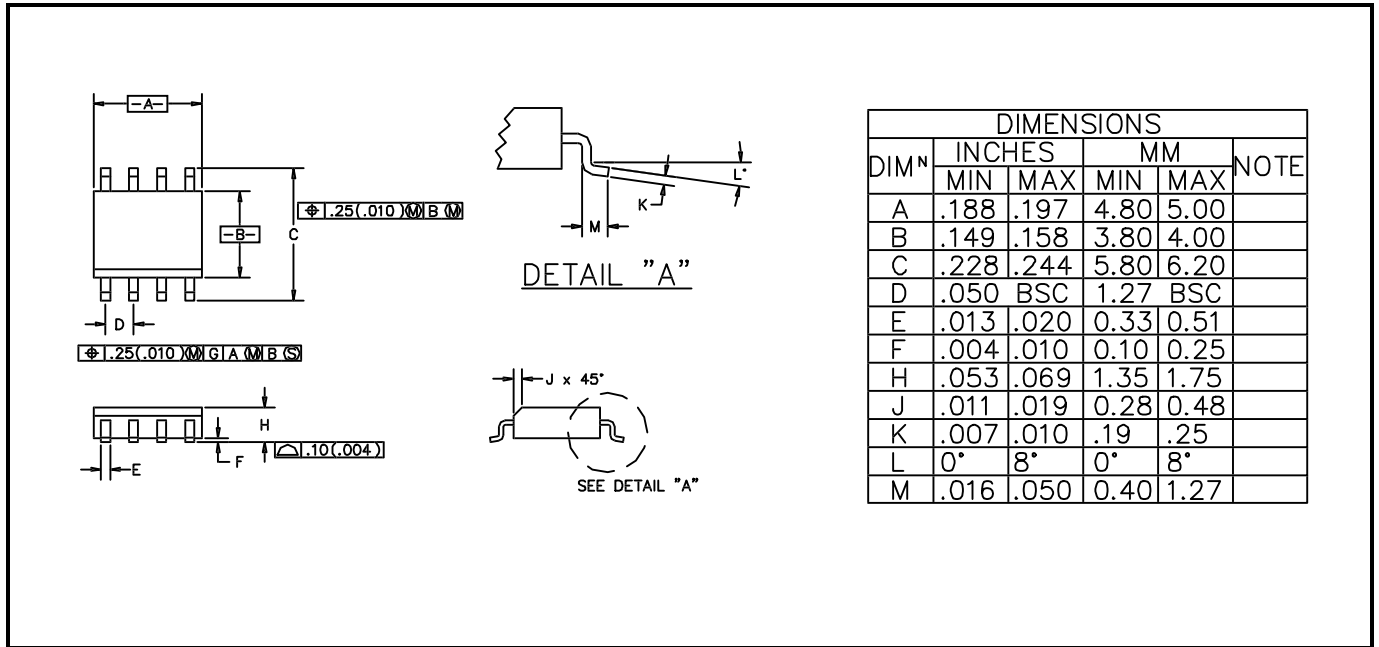
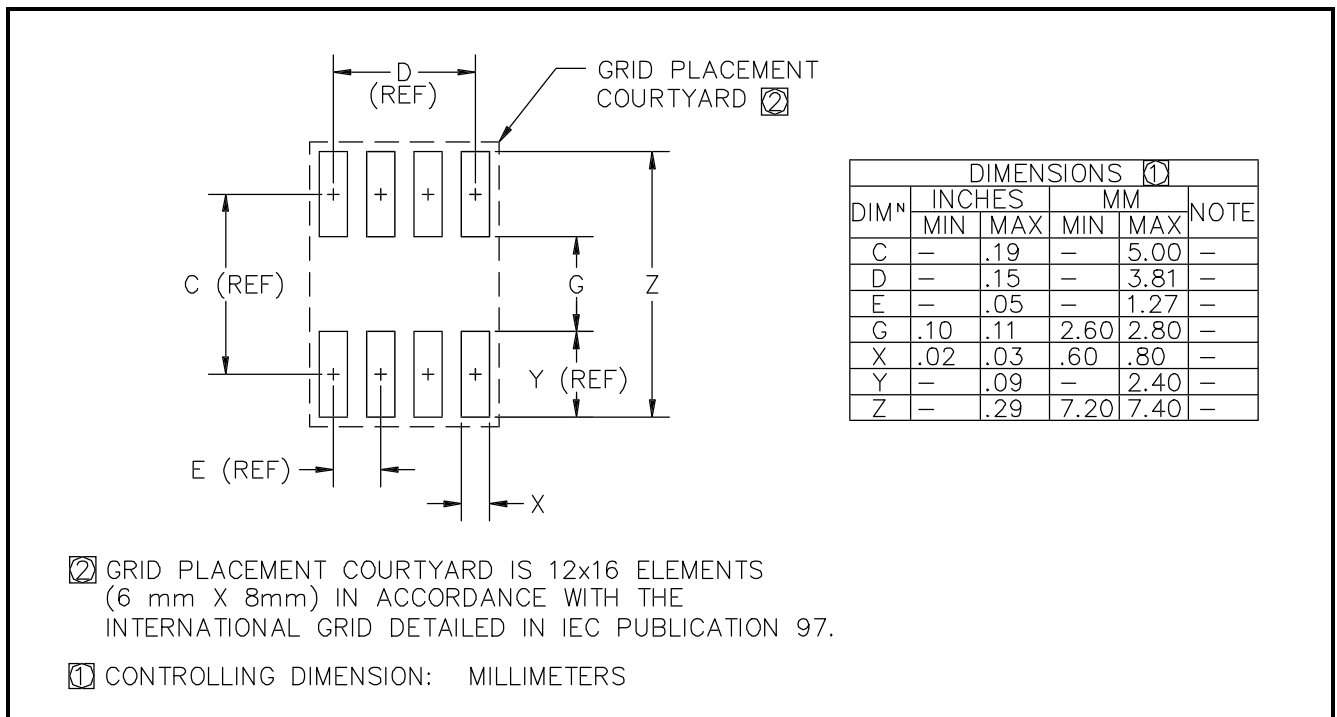
OUTLINE DRAWING SO-8

LAND PATTERN SO-8

This datasheet has been downloaded from:

www.DatasheetCatalog.com

Datasheets for electronic components.



LittleDiode supplies new, hard to find or obsolete electronic components and semiconductors all over the world.

With over two million different components listed you are sure to find the part you need.

Feel free to visit us today at our online store:

LittleDiode.com

Looking forward to providing you with the best possible service.