

# FAN1582

## 3A Adjustable/Fixed Ultra Low Dropout Linear Regulator

### Features

- Ultra Low dropout voltage, 0.4V typical at 3A
- Remote sense operation
- Fast transient response
- Load regulation: 0.05% typical
- 0.5% initial accuracy
- On-chip thermal limiting
- 5 Pin standard TO-220 and TO-263 packages

### Applications

- Pentium® Processors
- PowerPC®, AMD K5 and K6 processors
- Pentium support of GTL+ bus supply
- Low voltage logic supply
- Embedded Processor supplies
- Split plane regulator
- New 2.5V and 1.8V Logic Families

### Description

The FAN1582, FAN1582-1.5, and FAN1582-2.5 are ultra-low dropout regulators with 3A output current capability. These devices have been optimized for low voltage applications including VTT bus termination, where transient response and minimum input voltage are critical. The FAN1582 is ideal for low voltage microprocessor applications requiring a regulated output from 1.3V to 5.7V with a power input supply of 1.75V to 6.5V. The FAN1582-1.5 offers fixed 1.5V with 3A current capabilities for GTL+ bus VTT termination. The FAN1582-2.5 offers fixed 2.5V with 3A current capability for logic IC operation and processors while minimizing the overall power dissipation.

Current limit ensures controlled short-circuit current. On-chip thermal limiting provides protection against any combination of overload and ambient temperature that would create excessive junction temperatures.

The FAN1582 series regulators are available in the industry-standard 5-Pin TO-220 and TO-263 power packages.

Target Specification

### Typical Applications

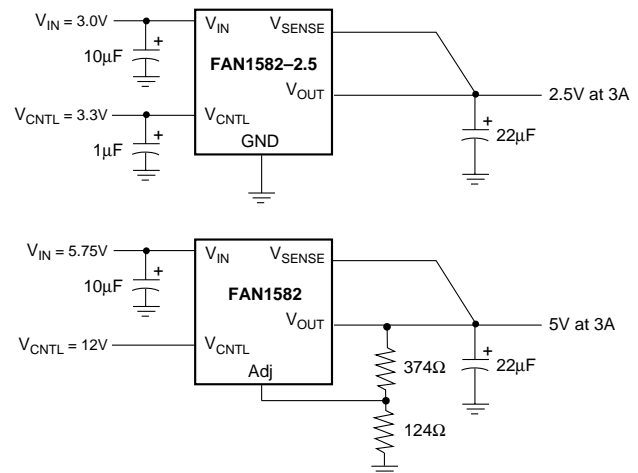
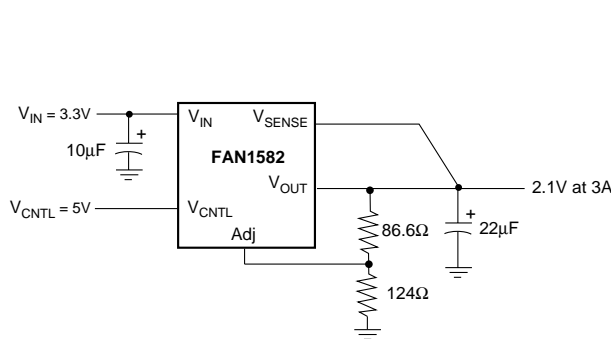

# Pin Assignments

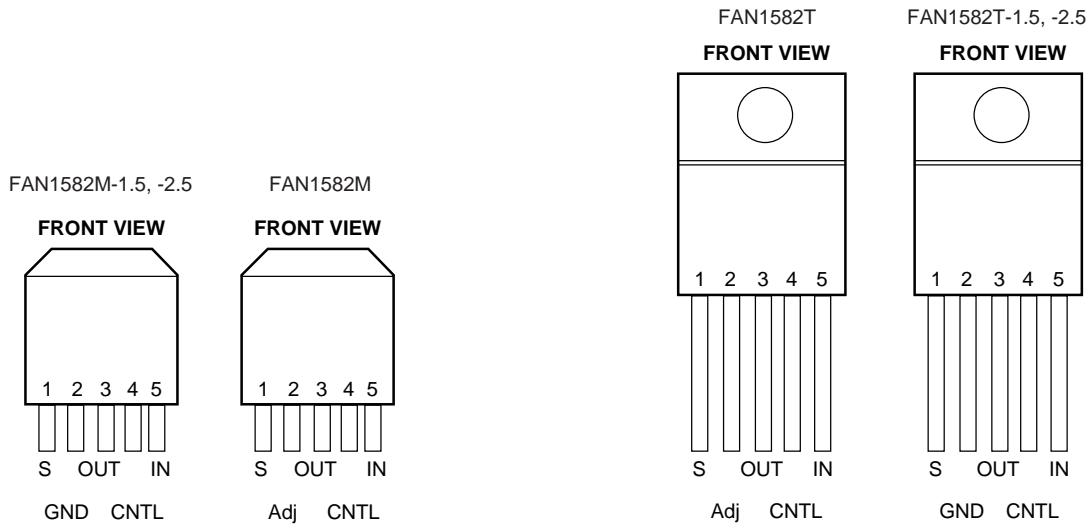

5-Lead Plastic TP-263  
 $\theta_{JC}=3^{\circ}\text{C/W}^*$

5-Lead Plastic TP-220  
 $\theta_{JC}=3^{\circ}\text{C/W}^*$

\*With package soldered to 0.5 square inch copper area over backside ground plane or internal power plane.  $\theta_{JA}$  can vary from  $20^{\circ}\text{C/W}$  to  $>40^{\circ}\text{C/W}$  with other mounting techniques.

Target Specification

## Pin Definitions

Pin Number	Pin Name	Pin Function Description
1	VSense	<b>Remote Voltage Sense.</b> Connect this pin to the load to permit true remote sensing and avoid trace drops.
2	ADJ/GND	<b>Adjust or Ground.</b> On the FAN1582, this pin forms the feedback to determine the output voltage. On the FAN1582-1.5 and -2.5, connect this pin to ground.
3	VOUT	<b>Output Voltage.</b> This pin and the tab are output.
4	VCNTL	<b>Control Voltage.</b> This pin draws small-signal power to control the FAN1582 circuitry. Connect to a voltage higher than $V_{IN}$ , as shown in the applications circuits.
5	VIN	<b>Input Voltage.</b>

## Internal Block Diagram

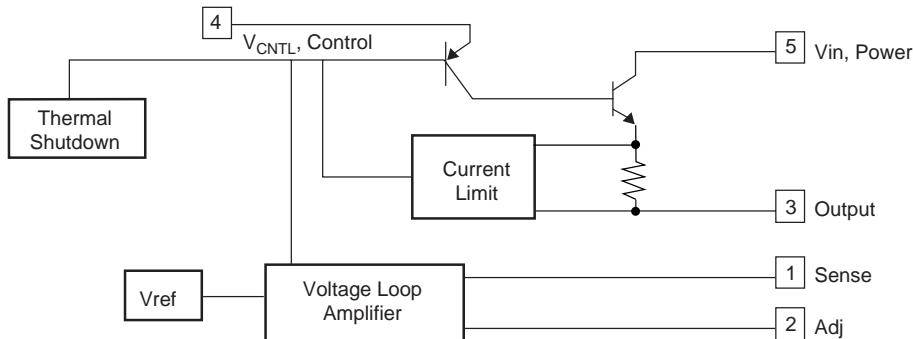

## Absolute Maximum Ratings

Parameter	Min.	Max.	Unit
V <sub>IN</sub>		7	V
V <sub>CNTL</sub>		13.2	V
Operating Junction Temperature Range	0	125	°C
Lead Temperature (Soldering, 10 sec.)		300	°C
Storage Temperature Range	-65	150	°C

## Electrical Characteristics

T<sub>J</sub>=25°C, V<sub>OUT</sub> = V<sub>S</sub>, unless otherwise specified.

The • denotes specifications which apply over the specified operating temperature range.

Parameter	Conditions	Min.	Typ.	Max.	Units
Reference Voltage <sup>3</sup>	V <sub>IN</sub> = 2.0V, V <sub>CNTL</sub> = 2.75V, I <sub>OUT</sub> = 10mA	1.243	1.250	1.257	V
Reference Voltage <sup>3</sup>	2.05V ≤ V <sub>IN</sub> ≤ 5.5V, 2.7V ≤ V <sub>CNTL</sub> ≤ 12V, 10mA ≤ I <sub>OUT</sub> ≤ 3A	• 1.237	1.250	1.263	V
Adjustable Output Voltage	3V ≤ V <sub>IN</sub> ≤ 7V (function of V <sub>out</sub> ), 10mA ≤ I <sub>OUT</sub> ≤ 3A	• V <sub>ref</sub>	1.5	5.7	V
Output Voltage <sup>4</sup>	3V ≤ V <sub>IN</sub> ≤ 7V, 10mA ≤ I <sub>OUT</sub> ≤ 3A	• 1.47	1.5	1.53	V
Output Voltage <sup>5</sup>	5.1V ≤ V <sub>IN</sub> ≤ 7V, 10mA ≤ I <sub>OUT</sub> ≤ 3A	• 2.474	2.5	2.526	V
Line Regulation <sup>1,2</sup>	1.75V ≤ V <sub>IN</sub> ≤ 5.5V, 2.5V ≤ V <sub>CNTL</sub> ≤ 12V, I <sub>OUT</sub> = 10mA	•	1	3	mV
Load Regulation <sup>1,2</sup>	V <sub>IN</sub> = 2.1V, V <sub>CNTL</sub> = 2.75V, 10mA ≤ I <sub>OUT</sub> ≤ 3A	•	1	5	mV
Dropout Voltage Minimum V <sub>CNTL</sub>	V <sub>IN</sub> = 2.05V, ΔV <sub>REF</sub> = 1%, I <sub>OUT</sub> = 3A	•	1.05	1.18	V
Dropout Voltage Minimum V <sub>IN</sub>	V <sub>CNTL</sub> = 2.75V, ΔV <sub>REF</sub> = 1%, I <sub>OUT</sub> = 3A		0.4	0.5	V
Dropout Voltage Minimum V <sub>IN</sub>	V <sub>CNTL</sub> = 2.75V, ΔV <sub>REF</sub> = 1%, I <sub>OUT</sub> = 3A	•	0.5	0.6	V
Current Limit	V <sub>IN</sub> = 2.05V, V <sub>CNTL</sub> = 2.75V	• 3.1			A
Control Pin Current	V <sub>IN</sub> = 2.05V, V <sub>CNTL</sub> = 2.75V, I <sub>OUT</sub> = 10mA	•	30	120	μA
Adjust Pin Current <sup>3</sup>	V <sub>IN</sub> = 2.05V, V <sub>CNTL</sub> = 2.75V	•	50	120	mA
Minimum Load Current	V <sub>IN</sub> = 3.3V, V <sub>CNTL</sub> = 5V	•	5.0	10	mA
Ripple Rejection	V <sub>IN</sub> = 3.75V, V <sub>CNTL</sub> = 3.75V, f = 120Hz, C <sub>OUT</sub> = 22μF Tantalum, I <sub>OUT</sub> = 1.5A	60	80		dB
Thermal Resistance, Junction to Case			3		°C/W
Thermal Regulation	T <sub>A</sub> = 25°C, 30ms pulse		0.002	0.02	%/W
Thermal Shutdown			150		°C

### Notes:

- See thermal regulation specifications for changes in output voltage due to heating effects. Load and line regulation are measured at a constant junction temperature by low duty cycle pulse testing.
- Line and load regulation are guaranteed up to the maximum power dissipation (18W). Power dissipation is determined by input/output differential and the output current. Guaranteed maximum output power will not be available over the full input/output voltage range.
- FAN1582 only.
- FAN1582-1.5 only.
- FAN1582-2.5 only.

Target Specification

# Typical Performance Characteristics

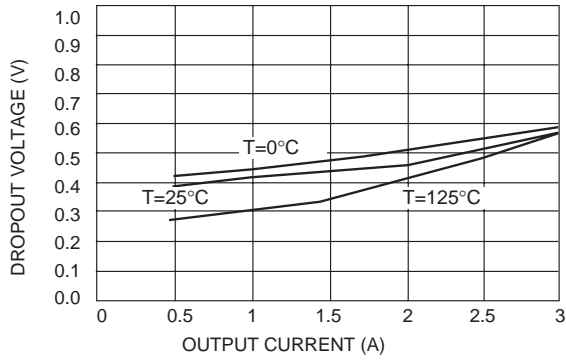

Dropout Voltage vs. Output Current

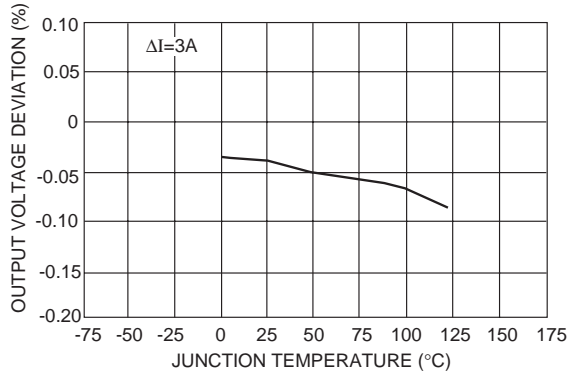

Load Regulation vs. Temperature

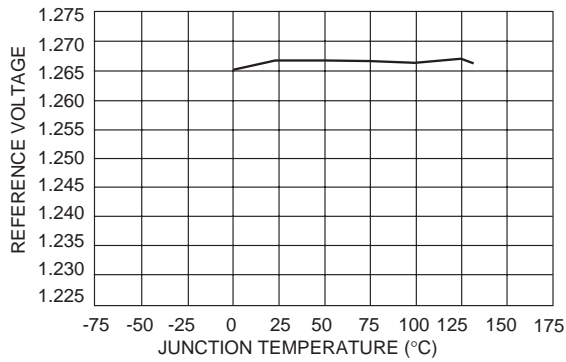

Reference Voltage vs. Temperature

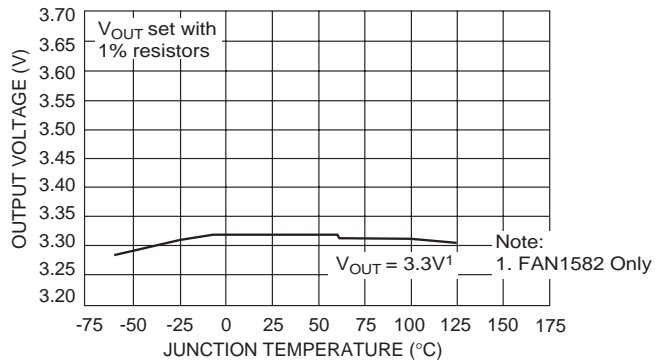

Output Voltage vs. Temperature

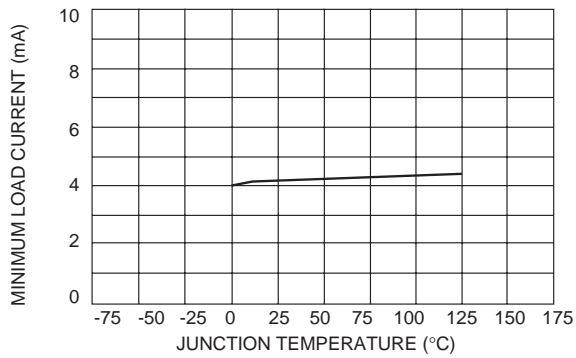

Minimum Load Current vs. Temperature

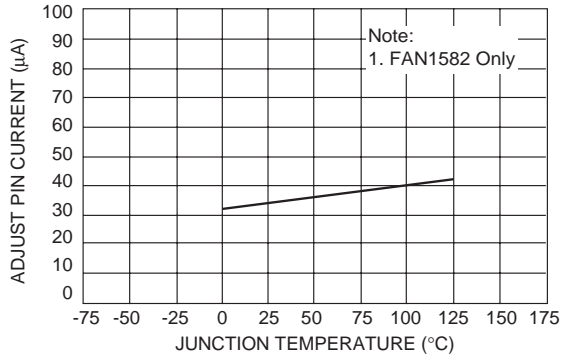

Adjust Pin Current vs. Temperature

Target Specification

## Typical Performance Characteristics (continued)

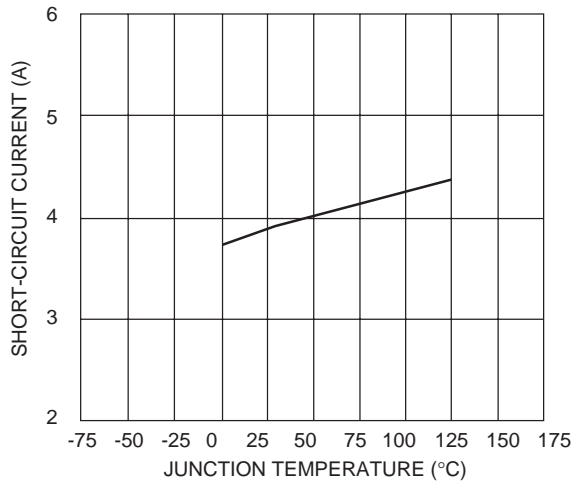

Short-Circuit Current vs. Temperature

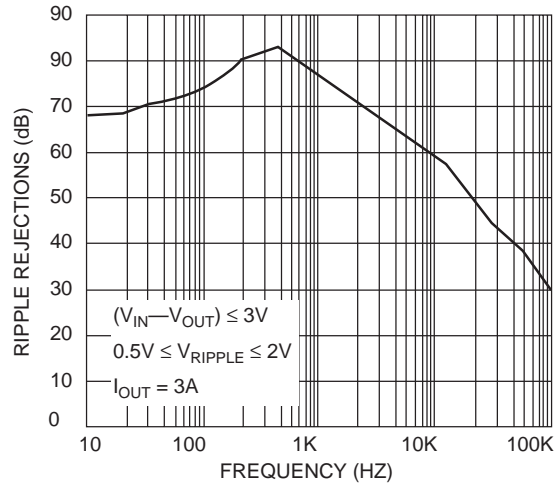

Ripple Rejection vs. Frequency

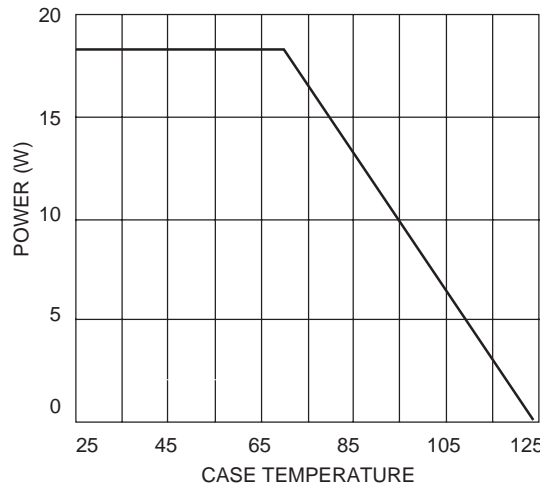

Maximum Power Dissipation

Target Specification

### General

The FAN1582, FAN1582-1.5, and FAN1582-2.5 are three-terminal regulators optimized for GTL+ VTT termination and logic applications. These devices are short-circuit protected, and offer thermal shutdown to turn off the regulator when the junction temperature exceeds about 150°C. The FAN1582 series provides low dropout voltage and fast transient response. Frequency compensation uses capacitors with low ESR while still maintaining stability. This is critical in addressing the needs of low voltage high speed microprocessor buses like GTL+.

### Stability

The FAN1582 series requires an output capacitor as a part of the frequency compensation. It is recommended to use a 22µF solid tantalum or a 100µF aluminum electrolytic on the output

to ensure stability. The frequency compensation of these devices optimizes the frequency response with low ESR capacitors. In general, it is suggested to use capacitors with an ESR of <math><1\Omega</math>. It is also recommended to use bypass capacitors such as a 22µF tantalum or a 100µF aluminum on the adjust pin of the FAN1582 for low ripple and fast transient response. When these bypassing capacitors are not used at the adjust pin, smaller values of output capacitors provide equally good results.

### Protection Diodes

In normal operation, the FAN1582 series does not require any protection diodes. For the FAN1582, internal resistors limit internal current paths on the adjust pin. Therefore, even with bypass capacitors on the adjust pin, no protection diode is needed to ensure device safety under short-circuit conditions.

A protection diode between the input and output pins is usually not needed. An internal diode between the input and the output pins on the FAN1582 series can handle microsecond surge currents of 50A to 100A. Even with large value output capacitors it is difficult to obtain those values of surge currents in normal operation. Only with large values of output capacitance, such as 1000µF to 5000µF, and with the input pin instantaneously shorted to ground can damage occur. A crowbar circuit at the input can generate those levels of current; a diode from output to input is then recommended, as shown in Figure 1. Usually, normal power supply cycling or system “hot plugging and unplugging” will not generate current large enough to do any damage.

The adjust pin can be driven on a transient basis ±7V with respect to the output, without any device degradation. As with any IC regulator, exceeding the maximum input-to-output voltage differential causes the internal transistors to break down and none of the protection circuitry is then functional.

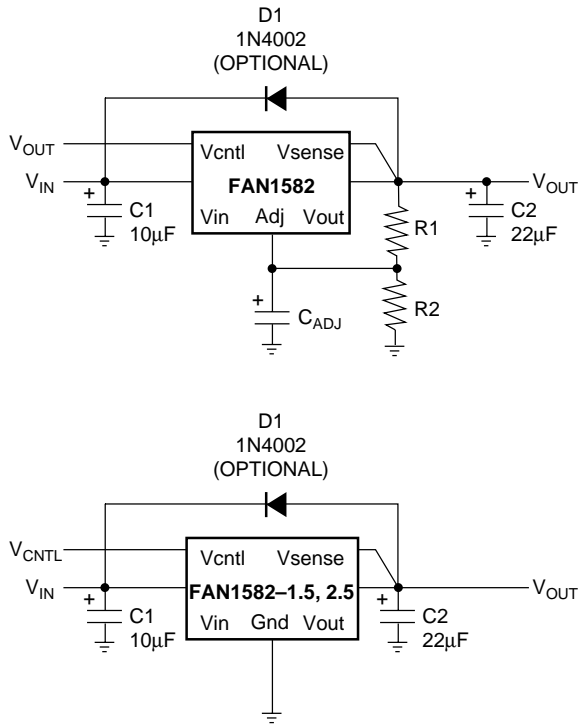

Figure 1. Optional Protection Diode

**Ripple Rejection**

In applications that require improved ripple rejection, a bypass capacitor from the adjust pin of the FAN1582 to ground reduces the output ripple by the ratio of  $V_{OUT}/1.25V$ . The impedance of the adjust pin capacitor at the ripple frequency should be less than the value of R1 (typically in the range of 100Ω to 120Ω) in the feedback divider network in Figure 1. Therefore, the value of the required adjust pin capacitor is a function of the input ripple frequency. For example, if R1 equals

100Ω and the ripple frequency equals 120Hz, the adjust pin capacitor should be 22µF. At 10kHz, only 0.22µF is needed.

**Output Voltage**

The FAN1582 regulator develops a 1.25V reference voltage between the output pin and the adjust pin (see Figure 2). Placing a resistor R1 between these two terminals causes a constant current to flow through R1 and down through R2 to set the overall output voltage. Normally, this current is the specified minimum load current of 10mA.

The current out of the adjust pin adds to the current from R1 and is typically 35µA. Its output voltage contribution is small and only needs consideration when a very precise output voltage setting is required.

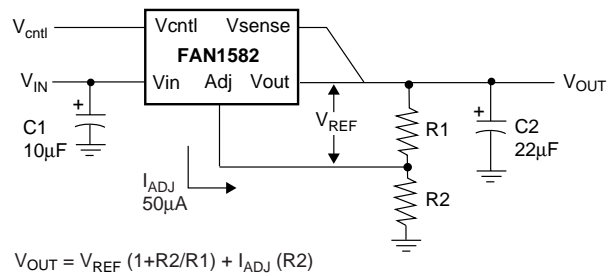

$$V_{OUT} = V_{REF} (1 + R2/R1) + I_{ADJ} (R2)$$

Figure 2. Basic Regulator Circuit

**Load Regulation**

The FAN1582 family provides true remote sensing, eliminating output voltage errors due to trace resistance. To utilize remote sensing, connect the VSENSE pin directly to the load, rather than at the VOUT pin. If the load is more than 1" away from the FAN1582, it may be necessary to increase the load capacitance to ensure stability.

**Thermal Considerations**

The FAN1582 series protect themselves under overload conditions with internal power and thermal limiting circuitry. However, for normal continuous load conditions, do not exceed maximum junction temperature ratings. It is important to consider all sources of thermal resistance from junction-to-ambient. These sources include the junction-to-case resistance, the case-to-heat sink interface resistance, and the heat sink resistance. Thermal resistance specifications have been developed to more accurately reflect device temperature and ensure safe operating temperatures. The electrical characteristics section provides a separate thermal resistance and maximum junction temperature for both the control circuitry and the power transistor. Calculate the maximum junction temperature for both sections to ensure that both thermal limits are met.

For example, look at using an FAN1582T-1.5 to generate 3A @ 1.5V ± 2% from a 3.3V source (3.2V to 3.6V).

Assumptions:

- $V_{in} = 3.6V$  worst case
- $V_{out} = 1.47V$  worst case
- $I_{out} = 3A$  continuous
- $T_A = 70^{\circ}C$
- $\Theta_{Case-to-Ambient} = 5^{\circ}C/W$  (assuming both a heatsink and a thermally conductive material)

The power dissipation in this application is:

$$PD = (V_{IN} - V_{OUT}) * (I_{OUT}) = (3.6-1.47) * (3) = 6.39W$$

From the specification table, for the power section:

$$T_J = T_A + (PD) * (\Theta_{Case-to-Ambient} + \Theta_{JC})$$

$$= 70 + (6.39) * (5 + 3) = 121^{\circ}C$$

The junction temperature is below the maximum rating.

Junction-to-case thermal resistance is specified from the IC junction to the bottom of the case directly below the die. This is the lowest resistance path for heat flow. Proper mounting ensures the best thermal flow from this area of the package to the heat sink. Use of a thermally conductive material at the case-to-heat sink interface is recommended. Use a thermally conductive spacer if the case of the device must be electrically isolated and include its contribution to the total thermal resistance.

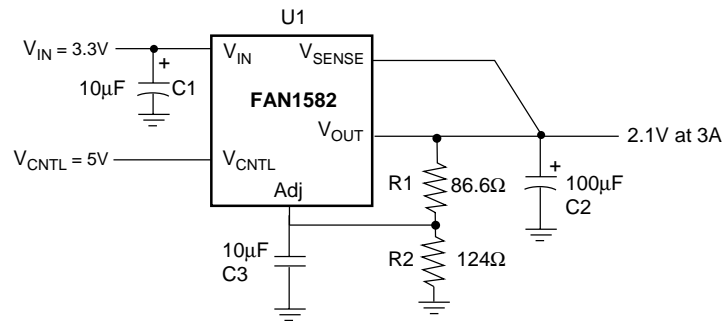

Figure 3. Application Circuit FAN1582

Table 1. Bill of Materials for Application Circuit for the FAN1582

Item	Quantity	Manufacturer	Part Number	Description
C1, C3	2	Xicon	L10V10	10µF, 10V Aluminum
C2	1	Xicon	L10V100	100µF, 10V Aluminum
R1	1	Generic		86.6Ω, 1%
R2	1	Generic		124Ω, 1%
U1	1	Fairchild	FAN1582T	3A Regulator

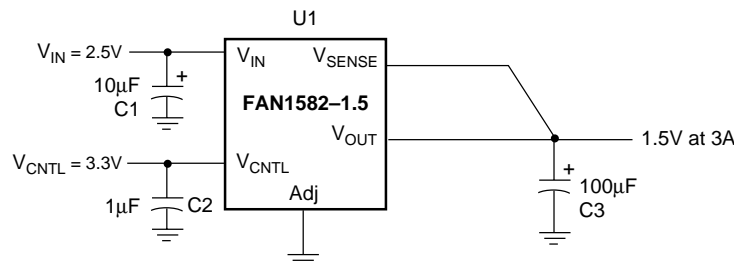

Figure 4. Application Circuit (FAN1582-1.5)

Table 2. Bill of Materials for Application Circuit for the RC1582-1.5

Item	Quantity	Manufacturer	Part Number	Description
C1	1	Xicon	L10V10	10μF, 10V Aluminum
C2	1	Any		1μF Ceramic
C3	1	Xicon	L10V100	100μF, 10V Aluminum
U1	1	Fairchild	FAN1582T-1.5	3A Regulator

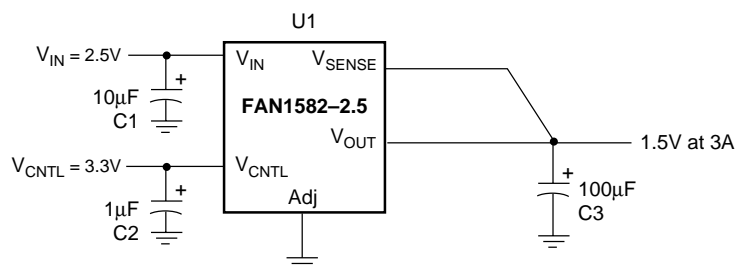

Figure 5. Application Circuit (FAN1582-2.5)

Table 3. Bill of Materials for Application Circuit for the RC1582-2.5

Item	Quantity	Manufacturer	Part Number	Description
C1	1	Xicon	L10V10	10μF, 10V Aluminum
C2	1	Any		1μF Ceramic
C3	1	Xicon	L10V100	100μF, 10V Aluminum
U1	1	Fairchild	FAN1582T-2.5	3A Regulator

Target Specification

# Mechanical Dimensions

## 5-Lead TO-263 Package

Symbol	Inches		Millimeters	
	Min.	Max.	Min.	Max.
A	.380	.405	9.65	10.29
B	.575	.625	14.60	15.88
C	.325	.380	8.25	9.66
D	-	.055	-	1.40
E	.020	.039	.50	.99
F	.060	.072	1.52	1.83
G	0.45	.055	1.14	1.40
H	.160	.190	4.06	4.83
J	.090	0.110	2.28	2.80
K	.018	.029	.457	.736
R	.017	.019	0.43	0.48

**Notes:**

1. Dimensions are exclusive of mold flash and metal burrs.
2. Standoff-height is measured from lead tip with ref. to Datum -B-.
3. Foot length is measured with ref. to Datum -A- with lead surface (at inner R).
4. Dimension exclusive of dambar protrusion or intrusion.
5. Formed leads to be planar with respect to one another at seating place -C-.

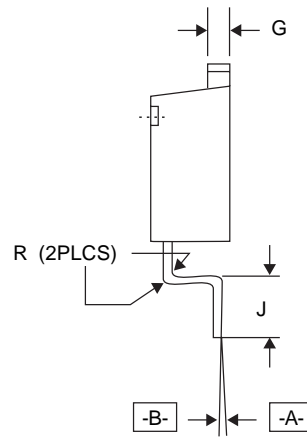
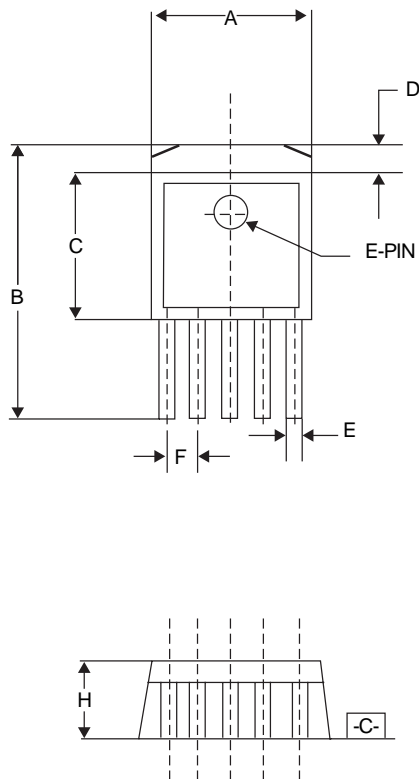

Target Specification

# Mechanical Demensions (continued)

## 5-Lead TO-220 Package

Symbol	Inches		Millimeters		Notes
	Min.	Max.	Min.	Max.	
A	.140	.190	3.56	4.83	
b	.025	.040	.63	1.02	
c1	.140	.220	.356	.559	
øP	.139	.161	3.53	4.09	
D	.560	.650	14.22	16.51	
E	.380	.420	9.65	10.67	
e	.062	.072	1.57	1.83	
e1	.263	.273	6.68	6.94	
F	.045	.055	1.14	1.40	
H1	.230	.270	5.84	6.87	
J1	.080	.115	2.04	2.92	
L	.500	.580	12.70	14.73	
Q	.100	.135	.254	.343	
$\alpha$	3°	7°	3°	7°	

**Notes:**  
 1. Dimension c1 apply for lead finish.

Target Specification

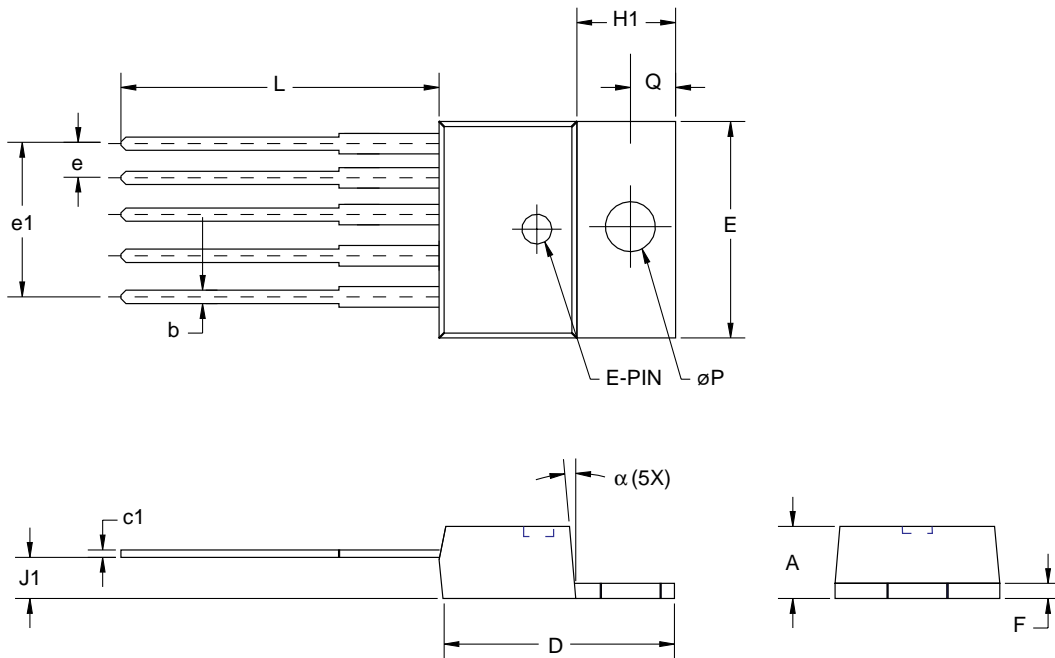

## Ordering Information

Product Number	Package
FAN1582M	TO-263
FAN1582T	TO-220
FAN1582M-1.5	TO-263
FAN1582T-1.5	TO-220
FAN1582M-2.5	TO-263
FAN1582T-2.5	TO-220

Target Specification

### LIFE SUPPORT POLICY

FAIRCHILD'S PRODUCTS ARE NOT AUTHORIZED FOR USE AS CRITICAL COMPONENTS IN LIFE SUPPORT DEVICES OR SYSTEMS WITHOUT THE EXPRESS WRITTEN APPROVAL OF THE PRESIDENT OF FAIRCHILD SEMICONDUCTOR CORPORATION. As used herein:

1. Life support devices or systems are devices or systems which, (a) are intended for surgical implant into the body, or (b) support or sustain life, and (c) whose failure to perform when properly used in accordance with instructions for use provided in the labeling, can be reasonably expected to result in a significant injury of the user.
2. A critical component in any component of a life support device or system whose failure to perform can be reasonably expected to cause the failure of the life support device or system, or to affect its safety or effectiveness.