

# FAN5609

## LED Driver with Adaptive Charge Pump DC/DC Converter

### Features

- Parallel LED Driver Supports All Forward Voltages
- Adaptive  $V_{OUT}$  Adjustment to the Highest Diode Voltage
- Internally Matched LED Current Sources
- No External Components Needed to Set LED Current
- Built-in Charge Pump has Three Modes of Operation:
  - Linear Regulation  $V_{IN} > 4.2V$
  - 3/2 DC-DC Converter and Regulation  $3.6V < V_{IN} < 4.2V$
  - 2/1 DC-DC Converter and Regulation  $2.7V < V_{IN} < 3.6V$
- Up to 86% Efficiency
- Low EMI, Low Ripple
- Up to 80mA Output Current ( $4 \times 20mA$ )
- Built-in DAC for Digital or PWM Brightness Control
- Can be Duty Cycle Modulated between 0 to 18mA
- 2.7V to 5.5V Input Voltage Range
- $I_{CC} < 2\mu A$  in Shutdown Mode
- 1MHz Operating Frequency
- Shutdown Isolates Output from Input
- Soft-Start Limits Inrush Current
- Short Circuit Protection
- Minimal External Components Needed
- Available in a 14-lead TSSOP Package
- Available in a 16-lead MLP Package

### Applications

- Cell Phones
- Handheld Computers
- PDA, DSC, MP3 Players
- Keyboard Backlight
- LED Displays

### Description

The FAN5609 generates regulated output current from a battery with input voltage varying between 2.7V to 5.5V. Switch reconfiguration and fractional switching techniques are utilized to achieve high efficiency over the entire input voltage range. A proprietary internal circuitry continuously monitors each LED current loop and automatically adjusts the generated output DC voltage to the lowest minimum value required by the LED having the highest forward voltage. This adaptive nature of the FAN5609 eliminates the need for LED pre-selection (matching) and ensures operation at high efficiency. When the input voltage is sufficiently high to sustain the programmed current level in the LEDs, the FAN5609 re-configures itself to operate as a linear regulator, and the DC-DC converter is turned off. An internal two-bit digital to analog converter provides programmability of the output currents. Only two 0.1 $\mu F$  bucket capacitors and two 4.7 $\mu F$  input/output capacitors are needed for proper operation.

Soft-start circuitry prevents excessive current draw during power on. The device has built-in short circuit protection.

### Typical Application

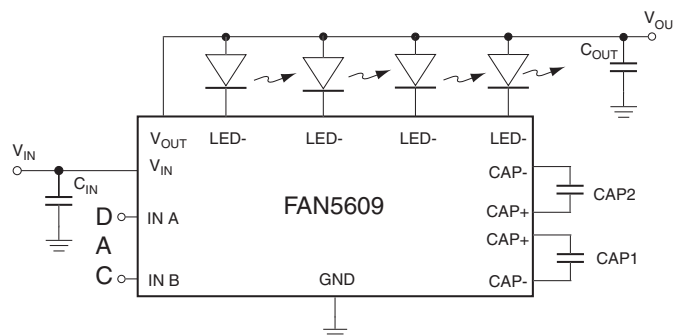

# Pin Assignments

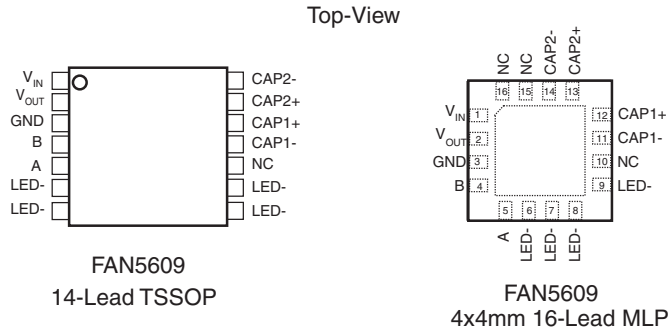

# Pin Descriptions

Pin No.	FAN5609		Pin Function Description
	14L-TSSOP	4mmX4mm 16L-MLP	
1	V <sub>IN</sub>	V <sub>IN</sub>	Input
2	V <sub>OUT</sub>	V <sub>OUT</sub>	Output to LEDs Anode
3	GND	GND	Ground
4	B	B	DAC B
5	A	A	DAC A
6	LED -	LED -	4th LED Cathode
7	LED -	LED -	3rd LED Cathode
8	LED -	LED -	2nd LED Cathode
9	LED -	LED -	1st LED Cathode
10	NC	NC	No Connection
11	CAP1-	CAP1-	Bucket capacitor negative terminal
12	CAP1+	CAP1+	Bucket capacitor positive connection
13	CAP2+	CAP2+	Bucket capacitor positive terminal
14	CAP2-	CAP2-	Bucket capacitor negative connection
15		NC	No Connection
16		NC	No Connection

# Test Circuit

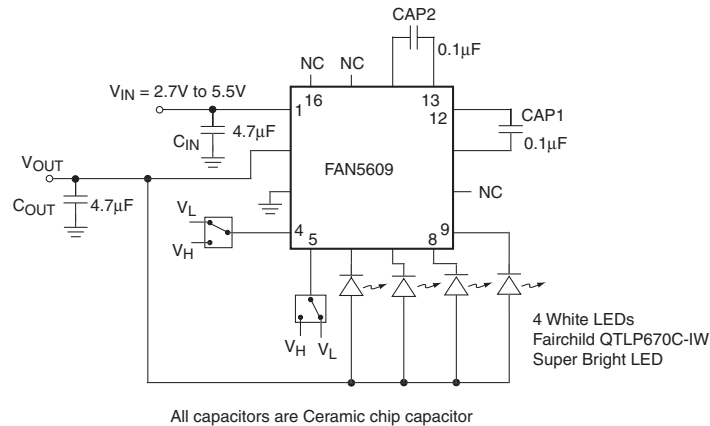

## Absolute Maximum Ratings

Parameter	Min	Max	Unit
V <sub>IN</sub> , V <sub>OUT</sub> , A, B Voltage to GND	-0.3	6.0	V
CAP+, CAP-, to GND	-0.3	V <sub>IN</sub> + 0.3	V
V <sub>OUT</sub> Short Circuit Duration		INDEFINITE	
Lead Soldering Temperature (10 seconds)		300	°C
Operating Junction Temperature Range		150	°C
Storage Temperature	-55	150	°C
Electrostatic Discharge Protection Level (Note 1)	HBM	4	kV
	CDM	2	

## Recommended Operating Conditions

Parameter	Min	Typ	Max	Unit
Input Voltage Range, V <sub>IN</sub>	2.7		5.5	V
Operating Ambient Temperature Range	-40	25	85	°C

## DC Electrical Characteristics

Unless otherwise noted, V<sub>IN</sub> = 3V to 5.5V, T<sub>A</sub> = 25°C. Refer to "Test Circuit". **Boldface** values indicate specifications over the ambient operating temperature range.

Parameter	Conditions	Min.	Typ.	Max.	Units
Quiescent Current	V <sub>OUT</sub> = 5.5V, No Load		1.5	4	mA
Output Current Accuracy I <sub>NOM</sub> = 20mA	A = High B = High	17	20	23	mA
LED to LED Current Matching	V <sub>IN</sub> = 5.5V A = B = High	<b>-5</b>		<b>+5</b>	%
Efficiency	V <sub>IN</sub> = 4.5V		85 to 75		%
	V <sub>IN</sub> = 3V		65 to 55		
Input A, B Threshold	Low	<b>0</b>		<b>0.3 × V<sub>IN</sub></b>	V
	High	<b>0.6 × V<sub>IN</sub></b>		<b>V<sub>IN</sub></b>	
V <sub>IN</sub> at Configuration Change	From 1:1 to 3:2		4.2		V
	From 3:2 to 2:1		3.6		
Oscillator Frequency		<b>0.80</b>	1	<b>1.2</b>	MHz
Supply Current, "OFF Mode"				<b>2</b>	μA

### Note:

- Using Mil Std. 883E, method 3015.7(Human Body Model) and EIA/JESD22C101-A (Charge Device Model)

## Block Diagram

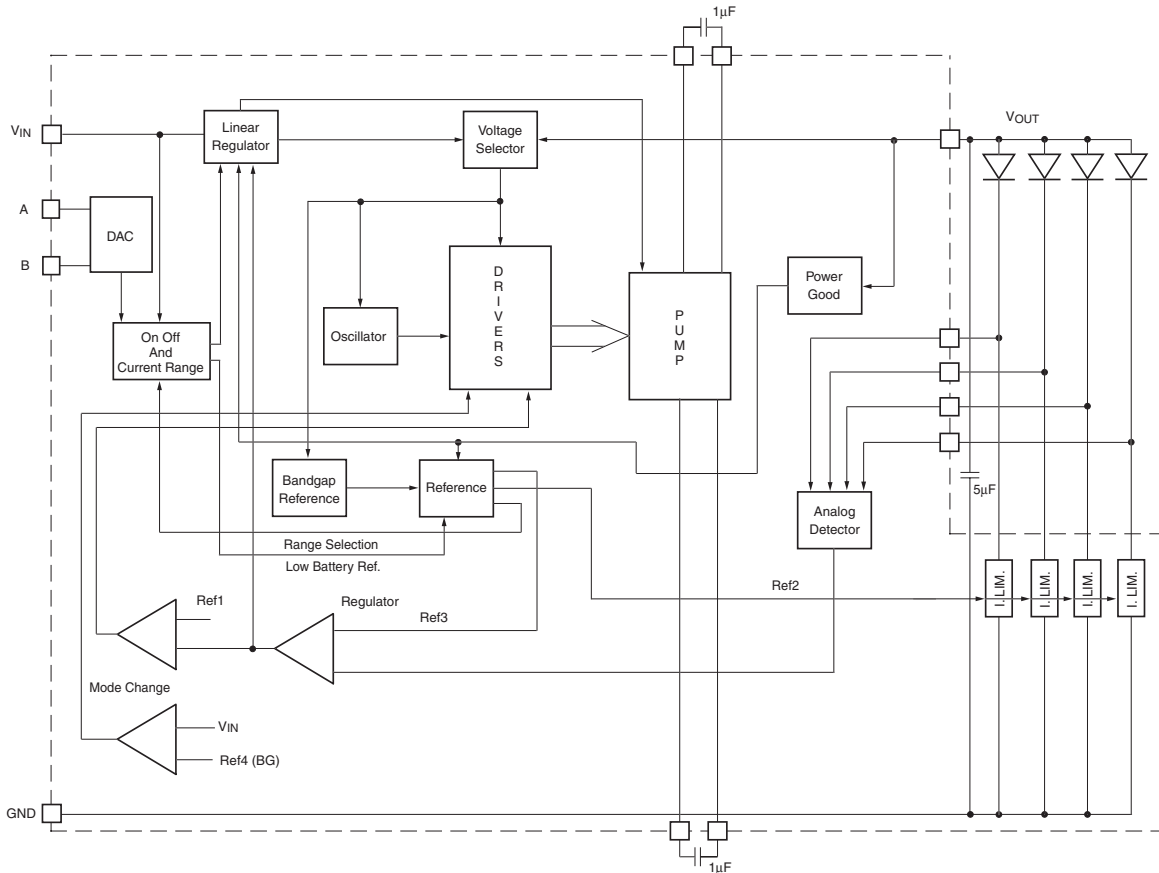

## Circuit Description

The FAN5609's switched capacitor DC/DC converter automatically configures its internal switches to achieve high efficiency and to provide tightly regulated output currents for the LEDs. An analog detector determines which diode requires the highest voltage in order to sustain the pre-set current levels, and adjusts the pump regulator accordingly. Every diode has its own linear current regulator. In addition, a voltage regulator controls the output voltage when the battery voltage is within a range where linear regulation can provide maximum possible efficiency. If the battery voltage is too low to sustain the diode current in the linear mode, a fractional 3:2 charge pump is enabled. When the battery voltage drops further and this mode is no longer sufficient to sustain proper operation, the pump is automatically reconfigured to operate in 2:1 mode. As the battery discharges and

the voltage decays, the FAN5609 switches between modes to maintain a constant current through LED throughout the battery life. The transition has hysteresis to prevent toggling.

### Supply Voltage

The internal supply voltage for the device is automatically selected from  $V_{IN}$  or  $V_{OUT}$  pins, whichever is higher.

### Soft Start

The soft-start circuit limits inrush current when the device is initially powered up and enabled. The reference voltage controls the rate of the output voltage ramp-up to its final value. Typical start-up time is 1ms. The rate of the output voltage ramp-up is controlled by an internally generated slow ramp, and an internal variable resistor limits the input current.

# Switch Configuration

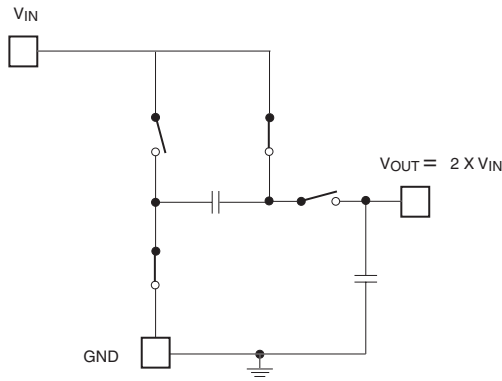

Figure 1  
Step-up, 2:1 configuration.  
Switch positions shown in charge phase.  
Reverse all switches for pump phase.

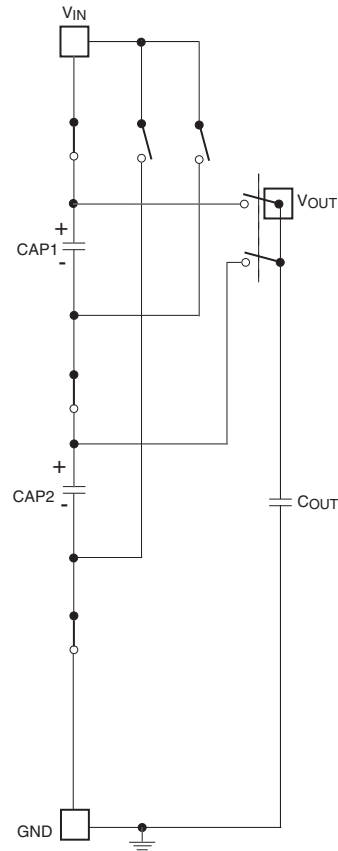

Figure 2  
Step-up  
3:2 configuration  
Switch positions shown in charge phase.  
Reverse all switches for pump phase.

## Shutdown and Short Circuit Current Limit

Set both DAC inputs low to shut down the device. Built-in short circuit protection limits the supply current to a maximum of 50mA.

## Digital Control

A digital-to-analog converter (DAC) allows selection of the following modes: OFF, 7mA, 14mA, 20mA, per diode. By turning the IN B pin ON and OFF, the current can be modulated between 7 to 20mA to achieve any  $I_{Average}$  value (PWM). In PWM mode, the modulating frequency has to be set sufficiently high in order to avoid a flickering effect (100Hz to 1kHz).

A	0	1	0	1
B	0	0	1	1
$I_{LED}$	OFF	7mA	14mA	20mA

## Digital Control with PWM

Any input can be modulated by a pulse train of variable duty cycle ( $\delta$ ). By turning ON and OFF DAC inputs A or B, the current can be continuously modulated to any average value between 1 to 19mA. For a maximum range of LED current, both A&B can be modulated at the same time.

## Digital Control with PWM

**A is PWM and B is Low.**  $I_{LED} \text{ (Average)} = \delta \times 7\text{mA}$ , where  $\delta$  is Duty Cycle. (Note 2)

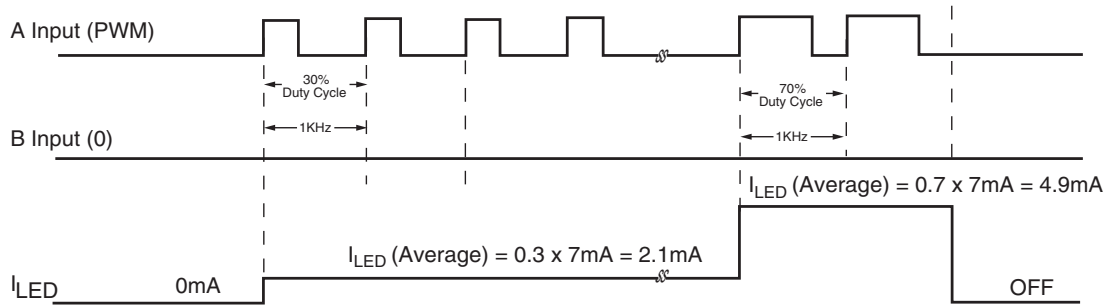

**A is High and B is PWM.**  $I_{LED} \text{ (Average)} = 6\text{mA} + \delta \times 12\text{mA}$ , where  $\delta$  is Duty Cycle. (Note 3, 4)

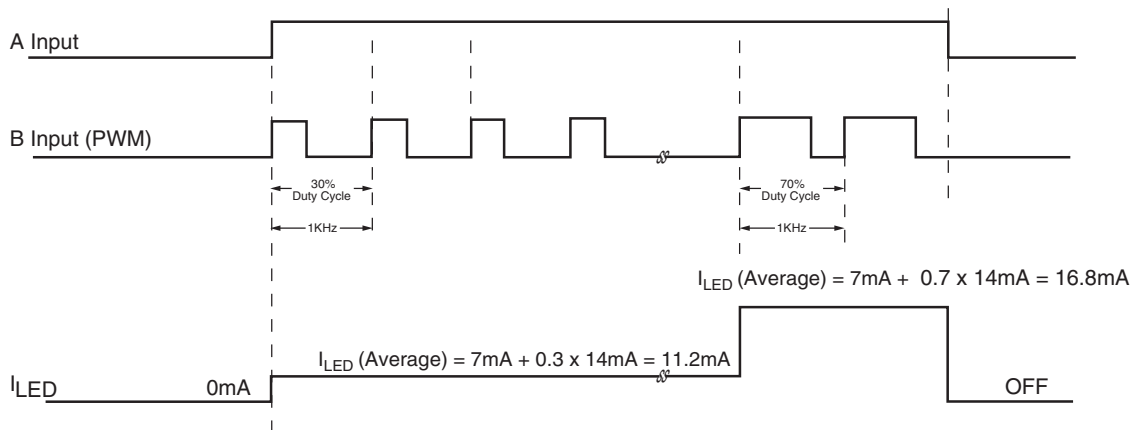

**Notes:**

2. Proportionally select the duty cycle to achieve a typical LED current between 1mA to 6mA.
3. If either input A or B is continuously high, the other input can be modulated at a maximum rate of 30kHz. Otherwise the maximum rate of modulation should be limited to 1kHz.
4. Proportionally select the duty cycle to achieve a typical LED current between 8mA to 19mA.

## Digital Control with PWM (Continued)

**A and B are PWM.**  $I_{LED} \text{ (Average)} = \delta \times 20\text{mA}$ , where  $\delta$  is Duty Cycle. (Note 3, 5)

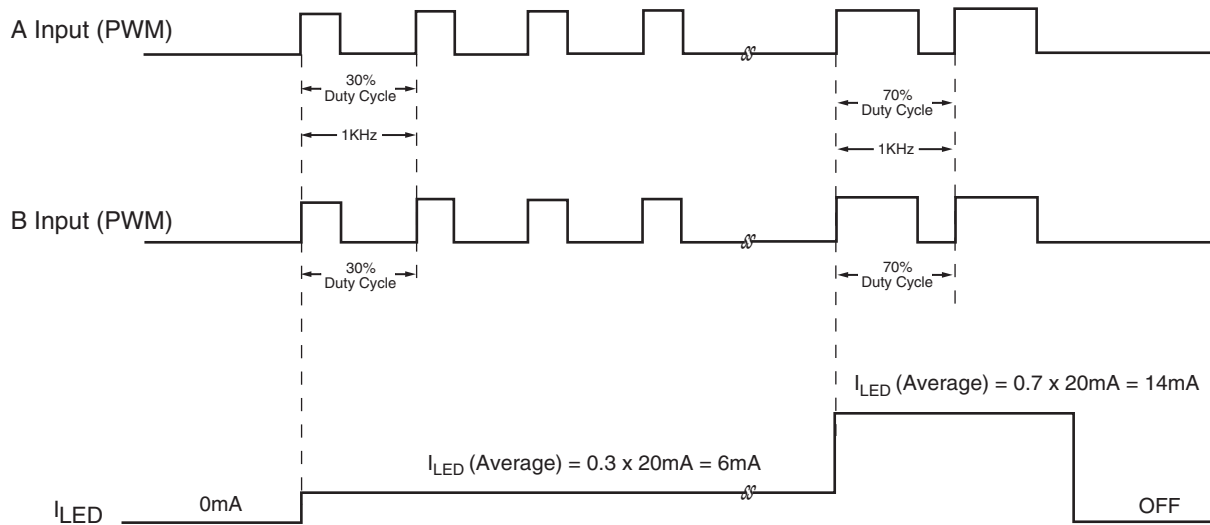

**Notes:**

5. Proportionally select the duty cycle to achieve a typical LED current between 1mA to 19mA.

## Application Information

### Selecting Capacitors

It is important to select the appropriate capacitor types and the values for use with the FAN5609. These capacitors determine parameters such as power efficiency, maximum sustainable load current by the charge pump, input and output ripple and start-up time.

In order to reduce ripple, both  $C_{IN}$  and  $C_{OUT}$  should be low ESR capacitor. Increasing the  $C_{OUT}$  capacitor reduces the output ripple voltage. However this will increase the power-on time. The  $C_{IN}$  value controls input ripple. If necessary, this ripple can be further reduced by powering the FAN5609 through a very small series inductor filter, as shown in Figure 3.

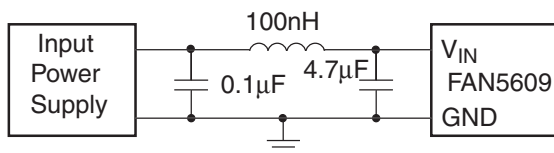

Figure 3.

$CAP1$  and  $CAP2$  control the current capability of the charge pump and affect the overall efficiency of the system. A lower value will improve efficiency, but it may limit the LED's currents at low input voltage. A capacitor of 100nF is optimal for  $4 \times 20\text{mA}$  load over the entire input voltage range of 2.7V to 4.2V. To save space and cost, and to increase efficiency, this value may be reduced to 10nF for loads less than  $4 \times 7\text{mA}$ .

### Pulse-Width-Modulated (PWM) Mode

Conversion errors are minimized and the best LED to LED matching is achieved over the entire range of average current settings, when PWM brightness control is used to modulate the LED current between zero and the maximum value ( $A=1, B=1$ ).

### PC Board Layout

For best performance, a solid ground plane is recommended on the back side of the PCB. The ground tails of  $C_{IN}$  and  $C_{OUT}$  should be connected together close to the GND pin of IC.

## Typical Performance Characteristics

T<sub>A</sub> = 25°C, C<sub>IN</sub> = C<sub>OUT</sub> = 4.7µF, CAP1 = CAP2 = 0.1µF, using Fairchild's QTLP670C-IW Super Bright LED.

**Regulated LED Current vs LED Forward Voltage**

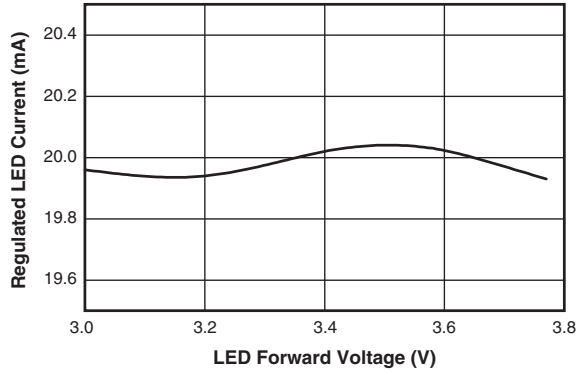

**DAC Inputs Threshold Voltage vs Input Voltage**

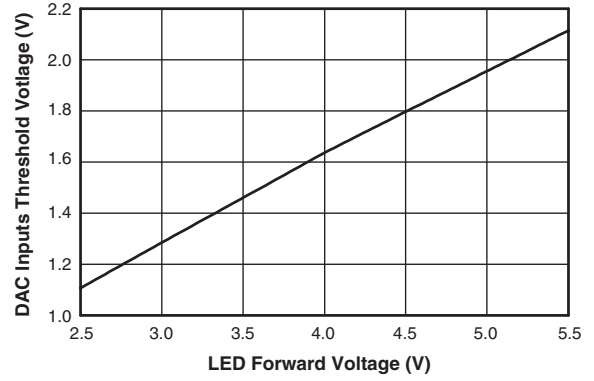

**Supply Current vs Input Voltage (4 LEDs)**

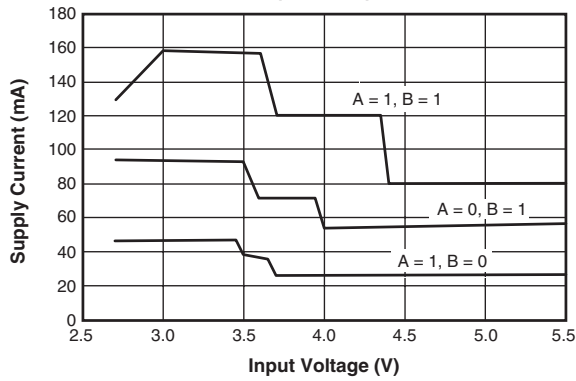

**Regulated LED Current vs Input Voltage**

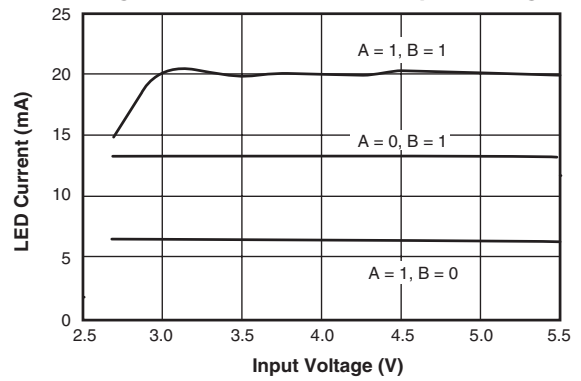

**Efficiency vs Input Voltage (4 LEDs x 20mA)**

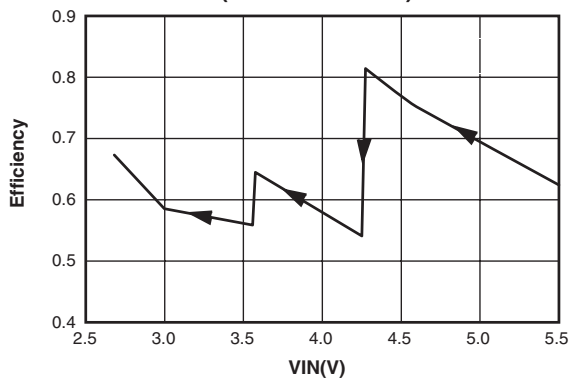

**Shutdown Current vs Input Voltage**

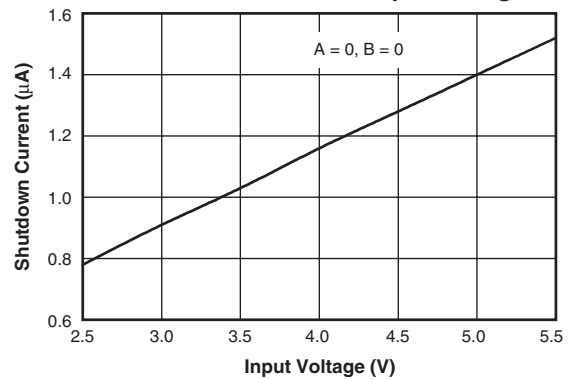

# Mechanical Dimensions

## 14-Lead TSSOP Package

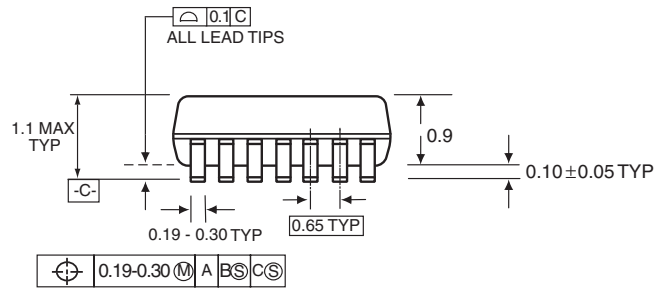
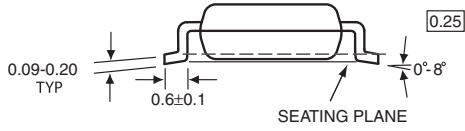
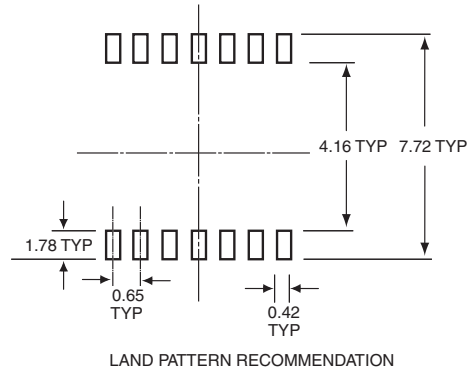
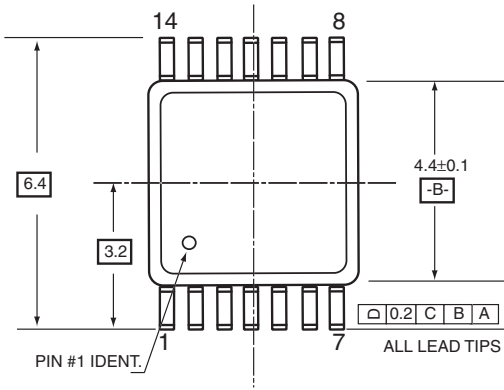



## Ordering Information

Product Number	Package Type	Order Code
FAN5609	14-Lead TSSOP	FAN5609MTCX
	4mmx4mm 16-Lead MLP	FAN5609MPX

### DISCLAIMER

FAIRCHILD SEMICONDUCTOR RESERVES THE RIGHT TO MAKE CHANGES WITHOUT FURTHER NOTICE TO ANY PRODUCTS HEREIN TO IMPROVE RELIABILITY, FUNCTION OR DESIGN. FAIRCHILD DOES NOT ASSUME ANY LIABILITY ARISING OUT OF THE APPLICATION OR USE OF ANY PRODUCT OR CIRCUIT DESCRIBED HEREIN; NEITHER DOES IT CONVEY ANY LICENSE UNDER ITS PATENT RIGHTS, NOR THE RIGHTS OF OTHERS.

### LIFE SUPPORT POLICY

FAIRCHILD'S PRODUCTS ARE NOT AUTHORIZED FOR USE AS CRITICAL COMPONENTS IN LIFE SUPPORT DEVICES OR SYSTEMS WITHOUT THE EXPRESS WRITTEN APPROVAL OF THE PRESIDENT OF FAIRCHILD SEMICONDUCTOR CORPORATION. As used herein:

1. Life support devices or systems are devices or systems which, (a) are intended for surgical implant into the body, or (b) support or sustain life, and (c) whose failure to perform when properly used in accordance with instructions for use provided in the labeling, can be reasonably expected to result in a significant injury of the user.
2. A critical component in any component of a life support device or system whose failure to perform can be reasonably expected to cause the failure of the life support device or system, or to affect its safety or effectiveness.



LittleDiode supplies new, hard to find or obsolete electronic components and semiconductors all over the world.

With over two million different components listed you are sure to find the part you need.

Feel free to visit us today at our online store:

[LittleDiode.com](http://LittleDiode.com)

Looking forward to providing you with the best possible service.