

FAN8422G

Floppy Disk Drive Spindle Motor Driver

Features

- Three-phase, full-wave, linear BLDC motor driver
- Commutation with only two hall sensors
- Generating index signal without an index hall sensor by special rotor magnetization
- Built-in soft switching drive circuit
- 300/360rpm selectable speed control circuit
- Snubberless output drive
- Chip enable function
- Built-in current limit circuit
- Built-in thermal shutdown circuit
- Low output saturation voltage
- TTL, 5V CMOS compatible digital inputs
- Built-in current-mode control circuit (IPEAK: 1A)

Description

The FAN8422G is a monolithic integrated circuit suitable for a three-phase spindle motor driver of floppy disk drive systems. It can make index signals without an index hall sensor by special rotor magnetization.

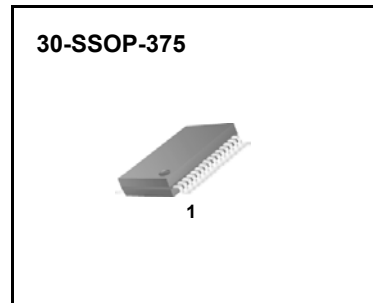

Typical Application

- 3.5-inch floppy disk drive(FDD) spindle motor driver

Ordering Information

Device	Package	Operating Temp.
FAN8422G	30-SSOP-375	0 ~ 75°C

Pin Assignments

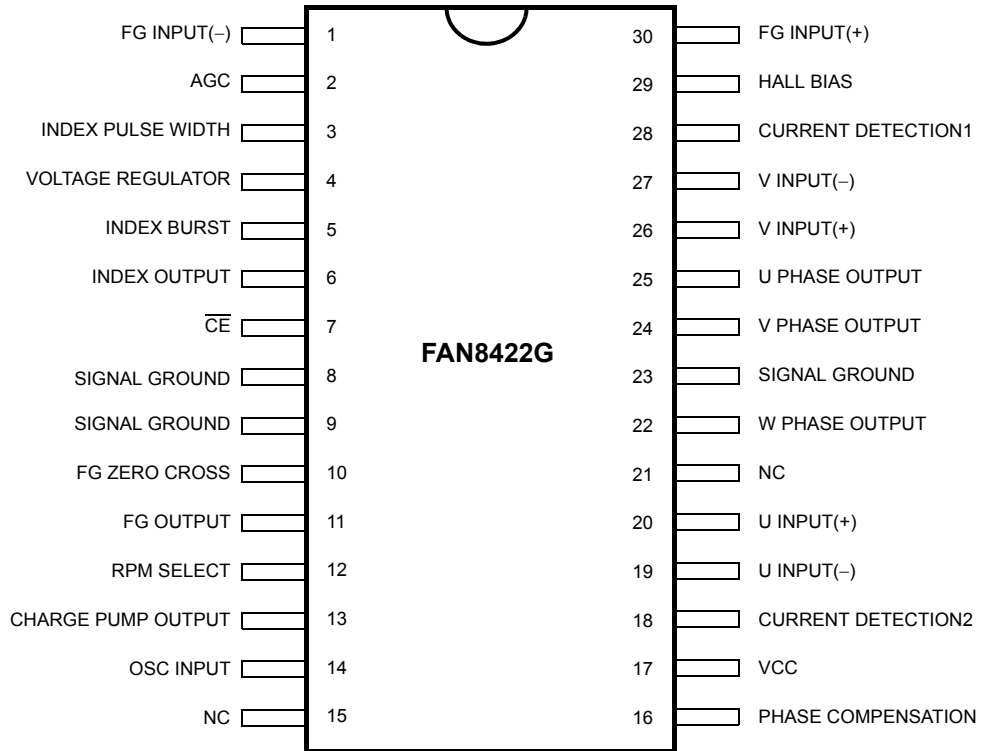

Pin Definitions

Pin Number	Pin Name	I/O	Pin Function Description
1	FG_INPUT (-)	I	Negative Input Pin FG Signal Amp.
2	AGC	I	Automatic Gain Control Input Pin
3	INDEX PULSE WIDTH	O	Index Pulse Width Detection Pin
4	VOLTAGE REGULATOR	O	Voltage Generator Output Pin
5	INDEX BURST	O	Index Pulse Width Detection Pin
6	INDEX OUTPUT	O	Index Pulse Output Pin
7	$\overline{\text{CE}}$	I	Chip Enable (Active Low)
8	SIGNAL GROUND	-	Signal Ground
9	SIGNAL GROUND	-	Signal Ground
10	FG ZERO CROSS	O	FG Signal Zero Cross Detection Pin
11	FG OUTPUT	O	FG Signal Output Pin
12	RPM SELECT	I	RPM Selection Pin (L: 300, H: 360rpm)
13	CHARGE PUMP OUTPUT	O	Charge Pump Output Pin
14	OSC INPUT	I	1MHz Oscillation Input Pin
15	NC	-	No Connection
16	PHASE COMPENSATION	I	Phase Compensation Cap. Connection Pin
17	V _{CC}	-	5V Power Supply Pin
18	CURRENT DETECTION2	I	Over Current Detection Pin
19	U INPUT (-)	I	Negative Input Pin of U Phase Amp
20	U INPUT (+)	I	Positive Input Pin of U Phase Amp
21	NC	-	No Connection
22	W PHASE OUTPUT	O	W Phase Output Pin
23	SIGNAL GROUND	-	Signal Ground
24	V PHASE OUTPUT	O	V Phase Output Pin
25	U PHASE OUTPUT	O	U Phase Output Pin
26	V INPUT (+)	I	Positive Input Pin of V Phase Amp
27	V INPUT (-)	I	Negative Input Pin of V Phase Amp
28	CURRENT DETECTION1	I	Over Current Detection Pin
29	HALL BIAS	I	Hall Sensor Bias Input Pin
30	FG INPUT (+)	I	Positive Input Pin of FG Signal Amp

Internal Block Diagram

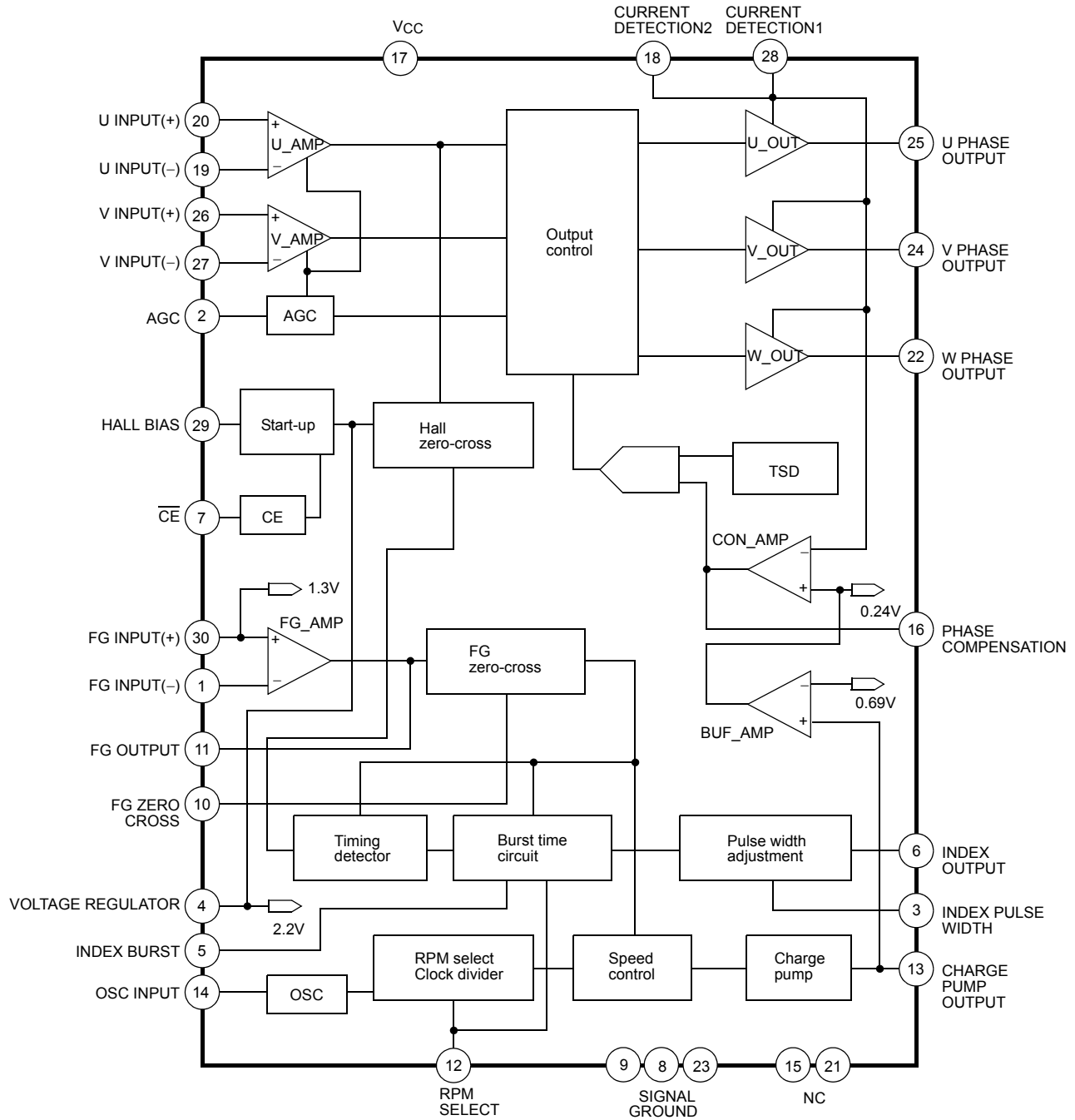

Absolute Maximum Rating (Ta=25°C)

Parameter	Symbol	Value	Unit
Maximum Power Supply Voltage	VCCMAX	7.0	V
Maximum Input Voltage	VINMAX	0 ~ VCC	V
Maximum Output Current	IOMAX	1	A
Continuous Output Current	IO	0.7	A
Power Dissipation	PD	1.5	W
Operating Temperature	TA	0 ~ 75	°C
Junction Temperature	TJ	150	°C
Storage Temperature	TSTG	-55 ~ +125	°C

Power Dissipation Curve

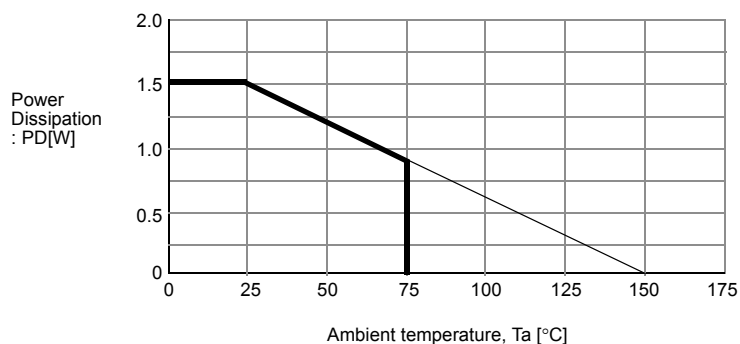

Power dissipation decreases in the rate of 12mW / °C when mounted on 76.2mm × 114.3mm × 1.6mm PCB (Phenolic resin material) and used above Ta=25°C.

Recommended Operating Conditions (Ta=25°C)

Parameter	Symbol	Min.	Typ.	Max	Unit
Supply Voltage	VCC	4.5	5.0	5.5	V
Ambient Operating Temperature Range	Ta	0	-	70	°C

Temperature Characteristic

Parameter	Symbol	Min.	Typ.	Max	Unit
Thermal Shutdown Temperature ^{Note}	TSD	125	150	-	°C

Note:

Design reference value

Electrical Characteristics

(Ta=25°C, VCC=5V, unless otherwise specified)

Parameter	Symbol	Conditions	Min.	Typ.	Max.	Unit
SUPPLY CURRENT						
Supply Current 1	ICCO	VCC=5.5V CE=H, RPM=L	-	1.0	2.0	mA
Supply Current 2	ICC	VCC=5.5V, CE=L	-	15	23	mA
CHIP ENABLE INPUT						
Input Current	ICE	CE=0~5V	-	5	10	μA
Input Low Voltage	VCEL	-	-	-	1.0	V
Input High Voltage	VCEH	-	3.5	-	-	V
RPM SELECT INPUT						
Input Current	IRPM	CE=0~5V	-	5	10	μA
Input Low Voltage	VRPML	-	-	-	1.0	V
Input High Voltage	VRPMH	-	3.5	-	-	V
HALL AMP						
Input Resistance ^{Note}	RIN	-	1	10	-	kΩ
Common Mode Input Voltage Range ^{Note}	VCOM	-	2.0	-	VCC	V
Differential Input Voltage Range ^{Note}	VDIF	-	140	-	420	mVPP
START-UP						
Hall Bias Voltage 1	VHB1	IH=4mA, CE=L	2.3	2.5	2.7	V
Hall Bias Voltage 2	VHB2	IH=10mA, CE=L	2.7	2.9	3.1	V
Reference Voltage	Vref	IO=1mA, CE=L	1.7	2.2	2.7	V
Bias Off Current	IHOFF	VH=5.5V, CE=H	-	5	10	μA
OUTPUT AMP						
Leakage Current	ICER	-	-	0.5	1	mA
Saturation Voltage 1	Vsat1	IO=0.35A	-	1.0	1.2	V
Saturation Voltage 2	Vsat2	IO=0.7A	-	1.3	1.8	V
BUFFER & CONTROL AMP						
Voltage Gain 1 ^{Note}	GCT1	-	-	-11	-	dB
Reference Voltage 1 ^{Note}	Vref1	Current limiter voltage	0.205	0.208	0.210	V
Reference Voltage 2 ^{Note}	Vref2	Control begin voltage	-	0.69	-	V

Note:

Design reference value

Electrical Characteristics (Continued)

(Ta=25°C, VCC=5V, unless otherwise specified)

Parameter	Symbol	Conditions	Min.	Typ.	Max.	Unit
CHARGE PUMP						
Charge Current	ICP-	RPM=L	-15	-20	-25	μA
Discharge Current	ICP+	RPM=L	15	20	25	μA
Current Ratio ^{Note}	IR	ICP+ / ICP-	0.9	1.0	1.1	-
Off Current	IOFF	VCP=0.63V	-	-	50	nA
Clamp Voltage ^{Note}	VCLP	-	-	1.3	1.5	V
FG AMP						
Output DC Voltage ^{Note}	VFG	-	1.0	1.3	1.6	V
Voltage Gain 2	GFG	-	24	34	44	dB
Input Voltage Range ^{Note}	VIN	-	2.0	-	20	mVP-P
Noise Margin 1 ^{Note}	ND	Differential noise	-	-	0.5	mVP-P
Noise Margin 2 ^{Note}	NC	Common mode noise	-	-	0.5	VP-P
SPEED CONTROL						
Count Range 1 ^{note}	N1	RPM=L	-	1666.5	-	-
Count Range 2 ^{Note}	N2	RPM=H	-	1388.5	-	-
Operating Freq.	FD	-	-	1.0	1.1	MHz
BURST ADJUSTMENT						
Input Current	IBI	-	-	1	2	μA
Threshold Voltage 1	VTH1	RPM=L	1.2	1.45	1.7	V
Threshold Voltage 2	VTH2	RPM=H	1.05	1.3	1.55	V
PULSE WIDTH ADJUSTMENT						
Ct2 Charge Current	ICT2	-	-19	-25	-36	μA
Threshold Voltage 3	VTH3	-	0.9	1.1	1.3	V
INDEX OUTPUT						
Output Leakage Current ^{Note}	IOH	-	-	1	2	μA
Output Low Voltage	VO1	IO=1mA	-	0.2	0.4	V

Note:

Design reference value

Application Information

1. Chip Enable

This function turns on or off all blocks by low or high signal (active low).

2. U, V And W Phase Output Amp

These amplifiers drive three phase outputs - U, V, and W which have 120 degree phase differences with each other. The three phase waveforms are made with the two hall sensor signals by synthesizing the third phase signal.

3. Speed Control Part

This function compares the real motor rotation frequency with the 300 or 360Hz pulse divided from 1MHz clock pulse for removing speed error when the motor is 'on' and speed error is detected by PLL. The speed error is sent to the charge pump, which repeats charging and discharging according to the error level. The charge pump output controls the output current to keep the rotational speed stable.

4. Sensorless Index Signal Generation

FAN8422G can make index signals without an index hall sensor by special rotor magnetization.

Typical Application Circuits

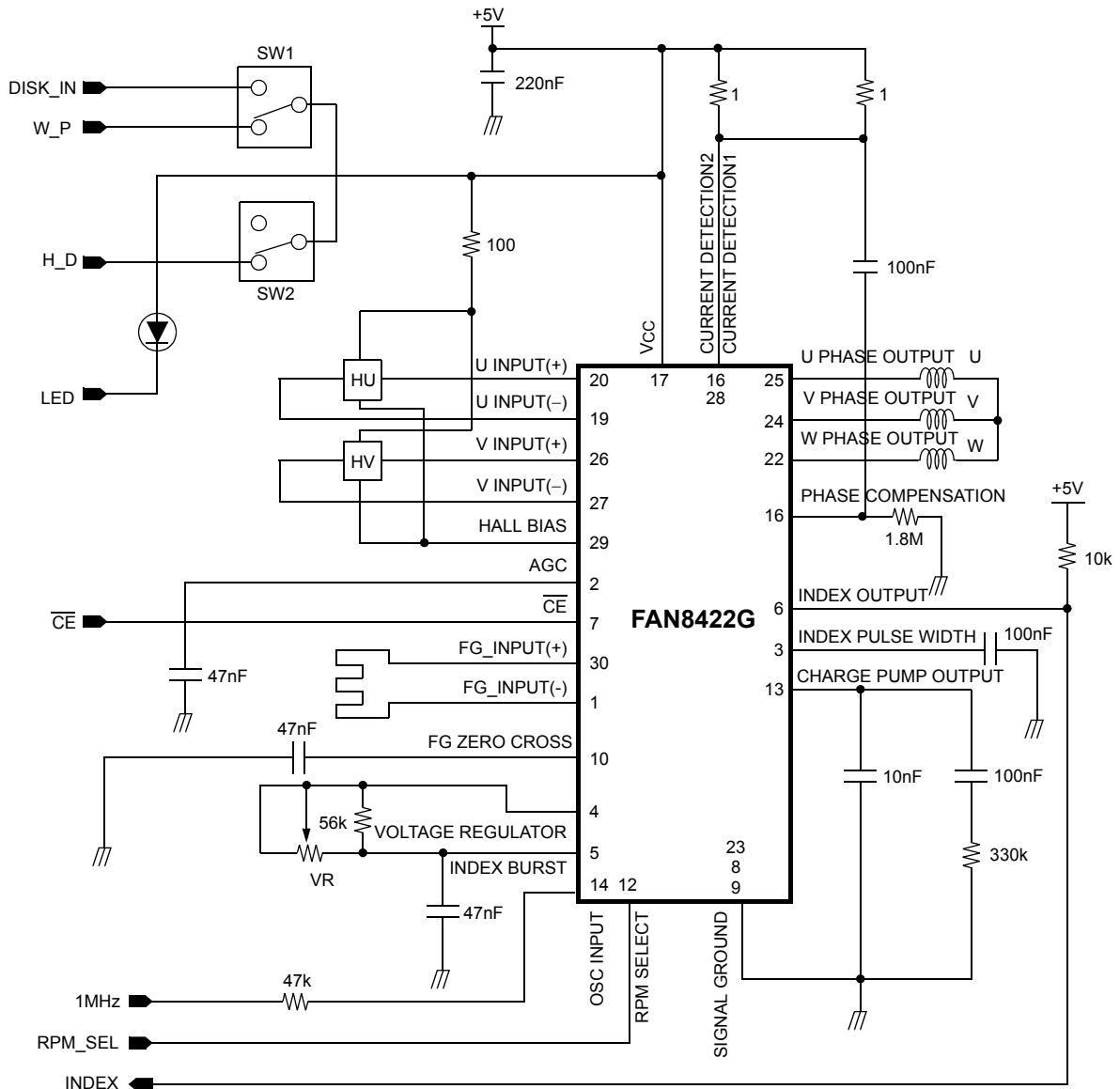

Mechanical Dimensions (Unit: mm)

Package Dimensions

30-SSOP-375

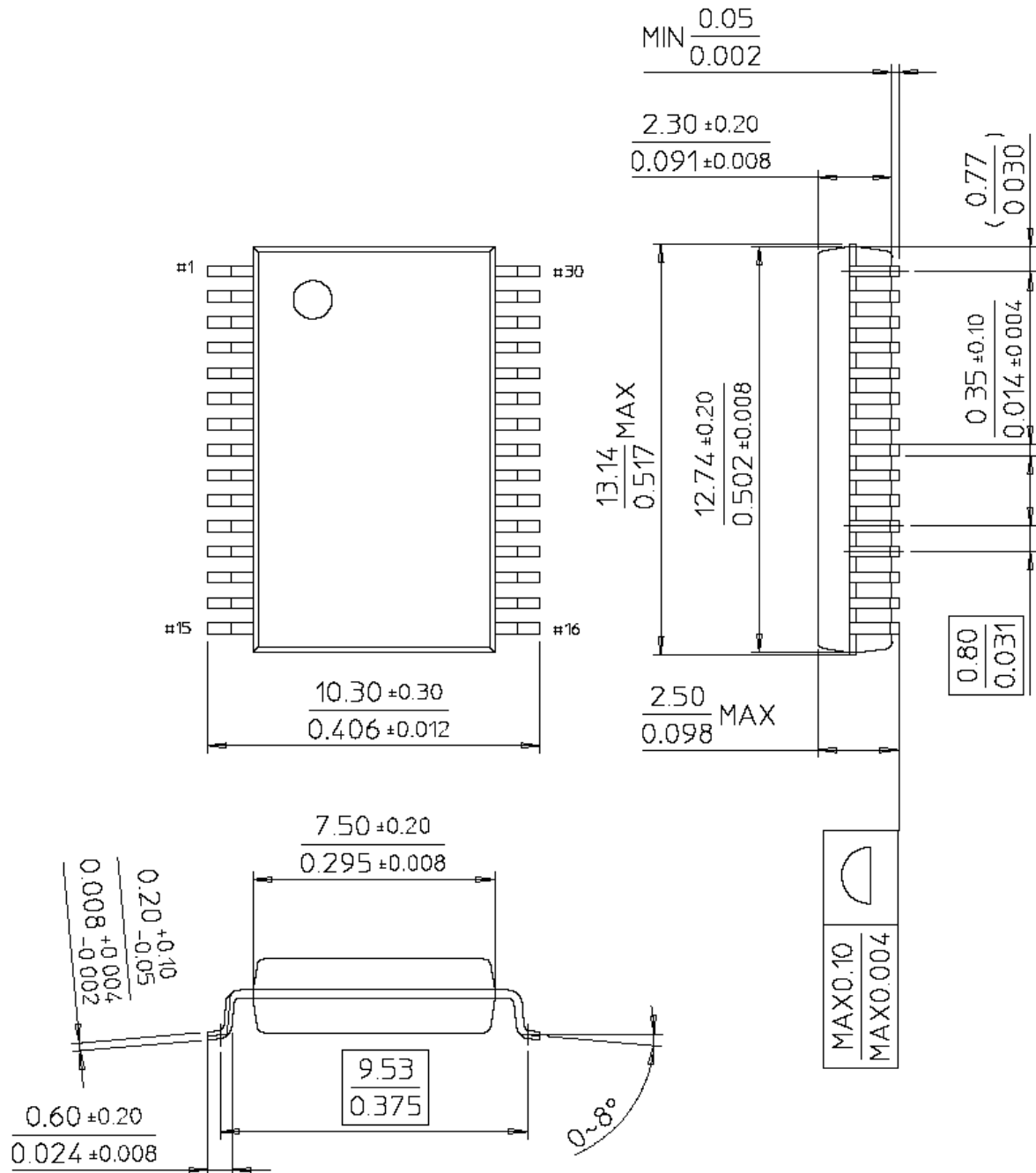

DISCLAIMER

FAIRCHILD SEMICONDUCTOR RESERVES THE RIGHT TO MAKE CHANGES WITHOUT FURTHER NOTICE TO ANY PRODUCTS HEREIN TO IMPROVE RELIABILITY, FUNCTION OR DESIGN. FAIRCHILD DOES NOT ASSUME ANY LIABILITY ARISING OUT OF THE APPLICATION OR USE OF ANY PRODUCT OR CIRCUIT DESCRIBED HEREIN; NEITHER DOES IT CONVEY ANY LICENSE UNDER ITS PATENT RIGHTS, NOR THE RIGHTS OF OTHERS.

LIFE SUPPORT POLICY

FAIRCHILD'S PRODUCTS ARE NOT AUTHORIZED FOR USE AS CRITICAL COMPONENTS IN LIFE SUPPORT DEVICES OR SYSTEMS WITHOUT THE EXPRESS WRITTEN APPROVAL OF THE PRESIDENT OF FAIRCHILD SEMICONDUCTOR CORPORATION. As used herein:

1. Life support devices or systems are devices or systems which, (a) are intended for surgical implant into the body, or (b) support or sustain life, and (c) whose failure to perform when properly used in accordance with instructions for use provided in the labeling, can be reasonably expected to result in a significant injury of the user.
2. A critical component in any component of a life support device or system whose failure to perform can be reasonably expected to cause the failure of the life support device or system, or to affect its safety or effectiveness.



LittleDiode supplies new, hard to find or obsolete electronic components and semiconductors all over the world.

With over two million different components listed you are sure to find the part you need.

Feel free to visit us today at our online store:

LittleDiode.com

Looking forward to providing you with the best possible service.