

FAN8727

Spindle + 4CH Motor Drive IC

Features

- Built-in power save circuit
- Built-in current limit circuit
- Built-in thermal shutdown circuit (TSD)
- Built-in hall bias
- Built-in FG signal output circuit
- Built-in rotational direction detecting circuit
- Built-in protection circuit for reverse rotation
- Built-in short brake circuit
- Built-in normal OP-AMP
- Built-in 4-CH balanced transformerless (BTL) driver
- Built-in BTL MUTE circuit (CH1-2, CH3 and CH4)
- Corresponds to 3.3V DSP

Description

The FAN8727 is a monolithic integrated circuit suitable for a 4-ch motor driver which drives the tracking actuator, focus actuator, sled motor, loading motor and 3-phase BLDC spindle motor of the MDP/CAR-MD/CAR-NAVIGATION system.



Typical Applications

- Mini disk player
- Digital video disk player
- Car mini disk player
- Car navigation system

Ordering Information

Device	Package	Operating Temperature
FAN8727	48-QFPH-1414	-35°C ~ +85°C

Pin Assignments

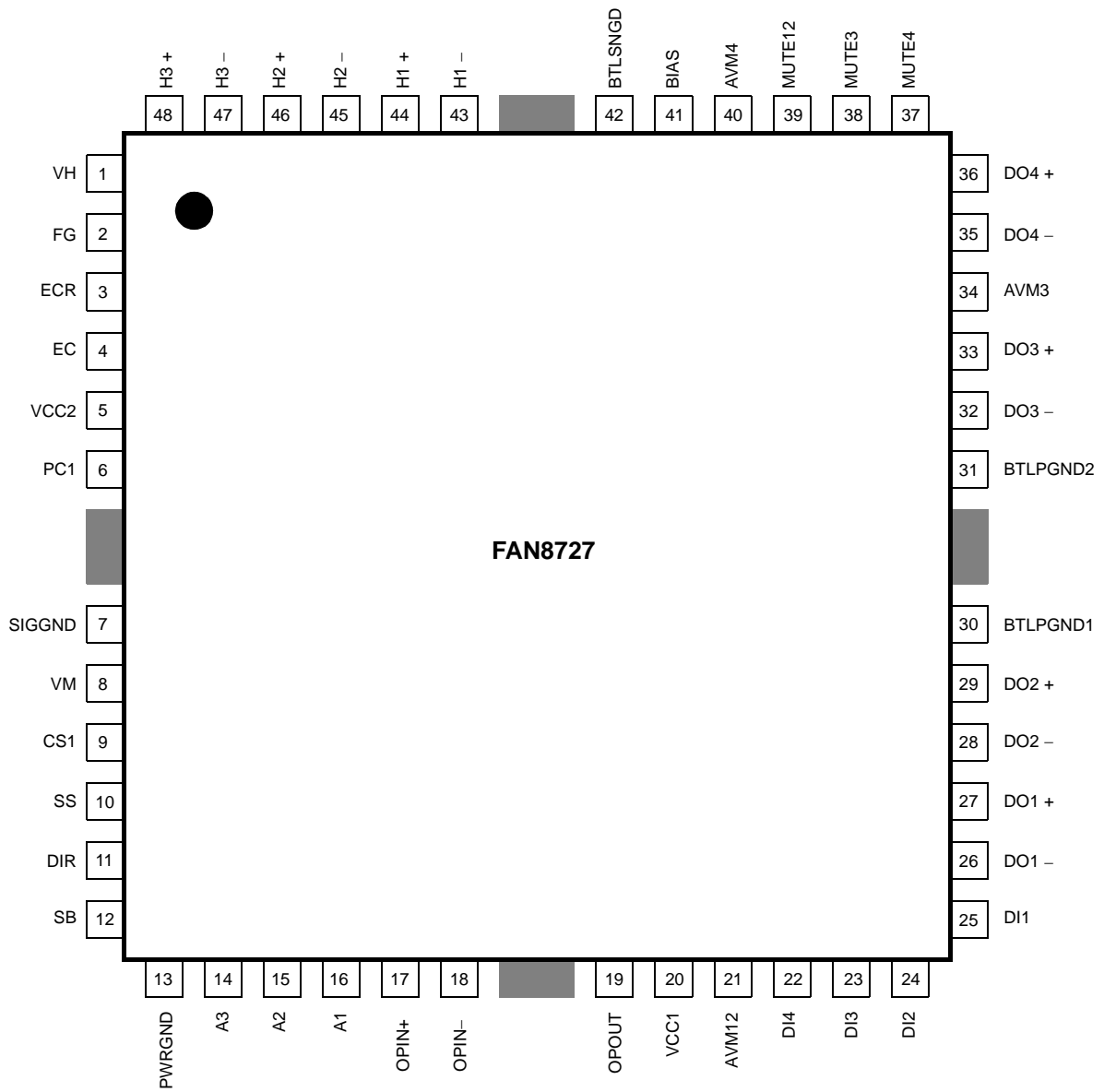

Pin Definitions

Pin Number	Pin Name	I/O	Pin Function Description
1	VH	I	HALL BIAS
2	FG	O	FG SIGNAL OUTPUT
3	ECR	I	TORQUE CONTROL REFERENCE
4	EC	I	TORQUE CONTROL SIGNAL
5	VCC2	–	SUPPLY VOLTAGE
6	PC1	–	PHASE COMPENSATION CAPACITOR
7	SIGGND	–	SIGNAL GROUND
8	VM	–	MOTOR SUPPLY VOLTAGE
9	CS1	I	CURRENT SENSOR
10	S/S	I	START/STOP
11	DIR	O	3-PHASE ROTATIONAL DIRECTION OUTPUT
12	SB	I	SHORT BRAKE
13	PWRGND	–	POWER GROUND
14	A3	O	3-PHASE OUTPUT 3
15	A2	O	3-PHASE OUTPUT 2
16	A1	O	3-PHASE OUTPUT 1
17	OPIN+	I	OP AMP INPUT (+)
18	OPIN-	I	OP AMP INPUT (-)
19	OPOUT	O	OP AMP OUTPUT
20	VCC1	–	SUPPLY VOLTAGE
21	AVM12	–	BTL CH-1, 2 MOTOR SUPPLY VOLTAGE
22	DI4	I	BTL DRIVE INPUT 4
23	DI3	I	BTL DRIVE INPUT 3
24	DI2	I	BTL DRIVE INPUT 2
25	DI1	I	BTL DRIVE INPUT 1
26	DO1-	O	BTL DRIVE 1 OUTPUT (-)
27	DO1+	O	BTL DRIVE 1 OUTPUT (+)
28	DO2-	O	BTL DRIVE 2 OUTPUT (-)
29	DO2+	O	BTL DRIVE 2 OUTPUT (+)
30	BTLPGND1	–	BTL POWER GROUND 1
31	BTLPGND2	–	BTL POWER GROUND 2
32	DO3-	O	BTL DRIVE 3 OUTPUT (-)
33	DO3+	O	BTL DRIVE 3 OUTPUT (+)

Pin Definitions (Continued)

Pin Number	Pin Name	I/O	Pin Function Description
34	AVM3	–	BTL CH3 MOTOR SUPPLY VOLTAGE
35	DO4-	O	BTL DRIVE 4 OUTPUT (-)
36	DO4+	O	BTL DRIVE 4 OUTPUT (+)
37	MUTE4	I	BTL DRIVE MUTE CH 4
38	MUTE3	I	BTL DRIVE MUTE CH 3
39	MUTE12	I	BTL DRIVE MUTE CH 1, 2
40	AVM4	–	BTL CH 4 MOTOR SUPPLY VOLTAGE
41	BIAS	–	BTL BIAS VOLTAGE
42	BTLSGND	–	BTL DRIVE SIGNAL GROUND
43	H1-	I	HALL1(-) INPUT
44	H1+	I	HALL1(+) INPUT
45	H2-	I	HALL2(-) INPUT
46	H2+	I	HALL2(+) INPUT
47	H3-	I	HALL3(-) INPUT
48	H3+	I	HALL3(+) INPUT

Internal Block Diagram

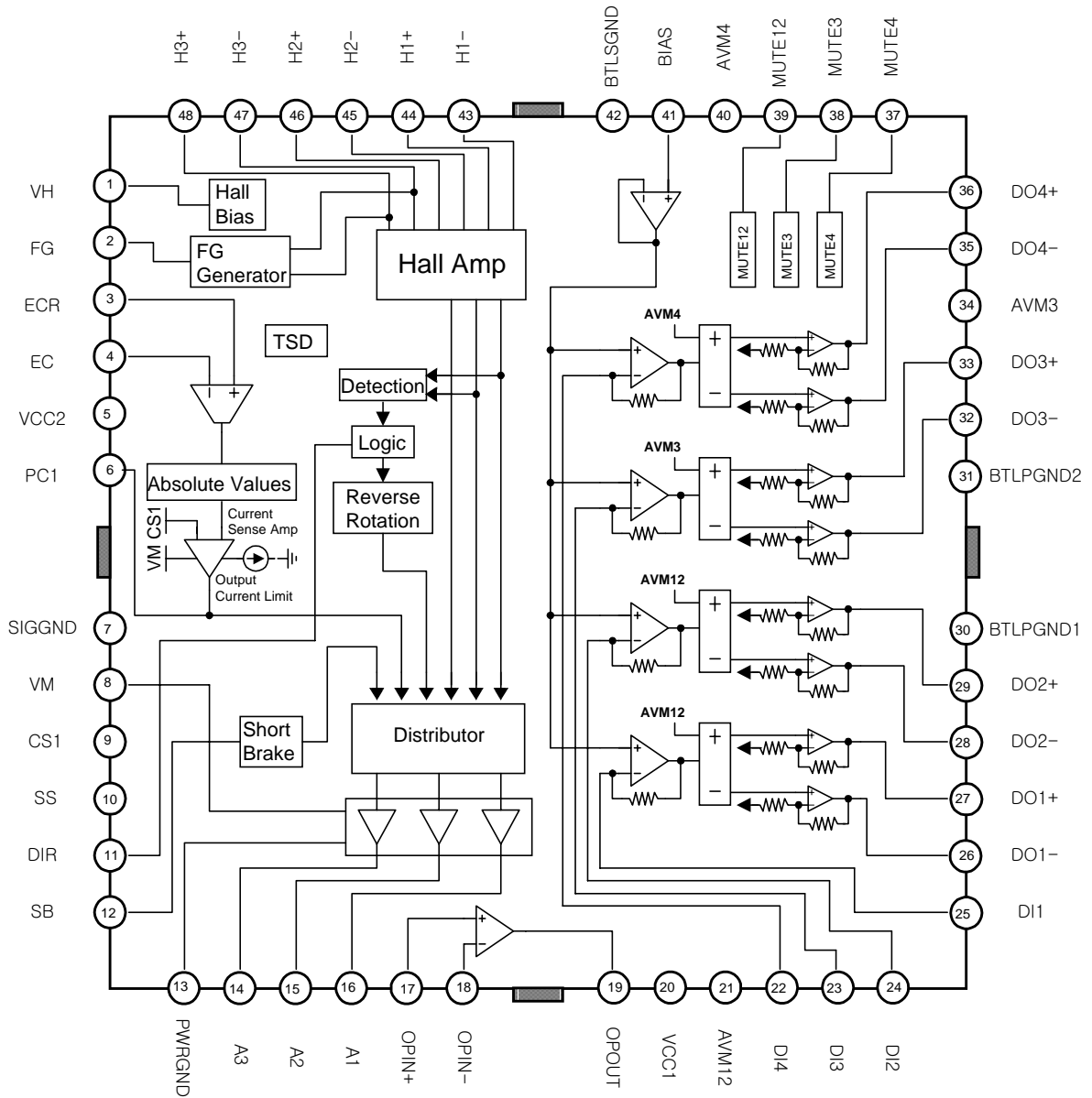

Equivalent Circuits

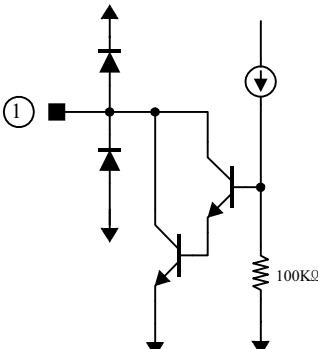
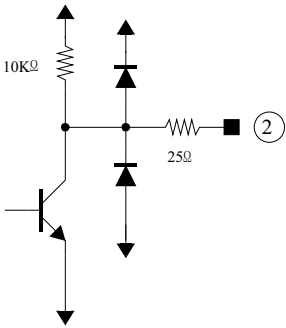
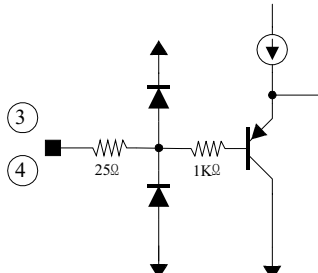
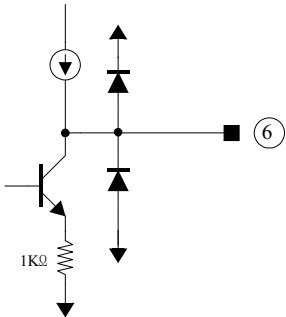
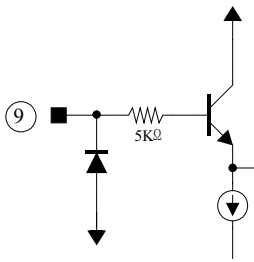
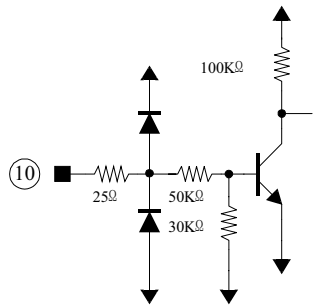
HALL BIAS	FG SIGNAL OUTPUT
	
TORQUE CONTROL REFERENCE & SIGNAL	PHASE COMPENSATION CAPACITOR
	
CURRENT DETECTOR	START/STOP
	

Equivalent Circuits (Continued)

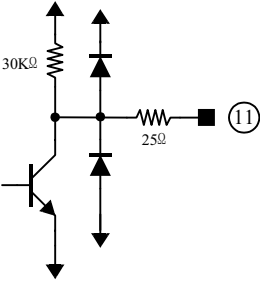
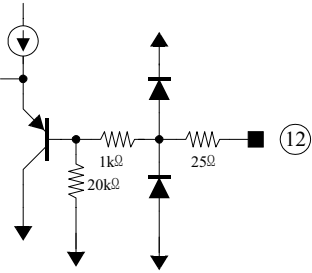
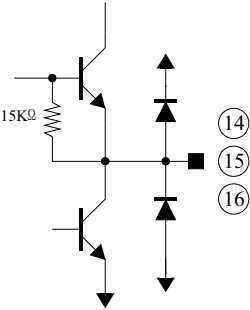
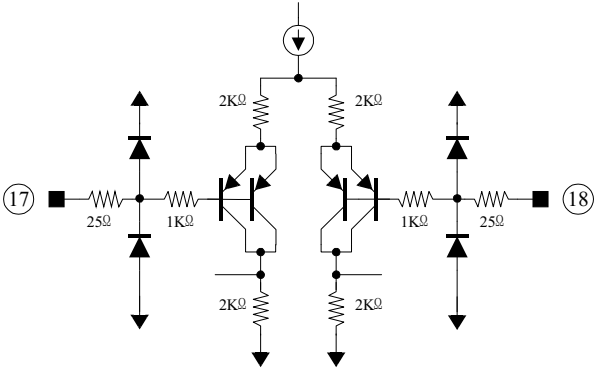
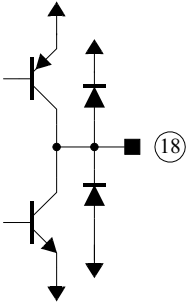
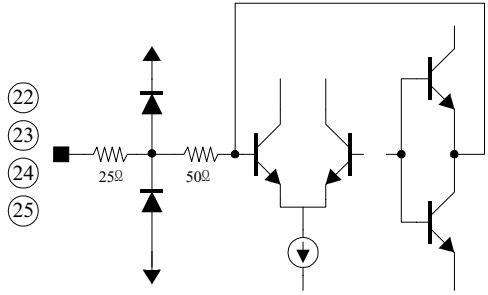
3-PHASE ROTATIONAL DIRECTION OUTPUT	SHORT BRAKE
	
3-PHASE OUTPUT	OP AMP INPUT
	
OP AMP OUTPUT	BTL DRIVE INPUT
	

Equivalent Circuits (Continued)

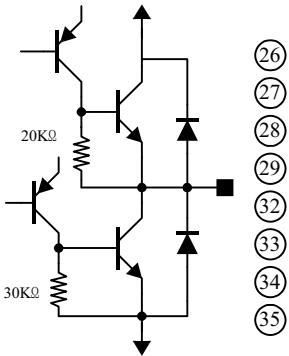
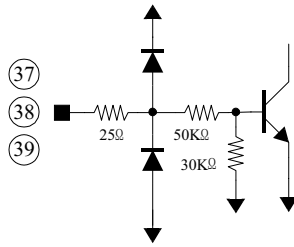
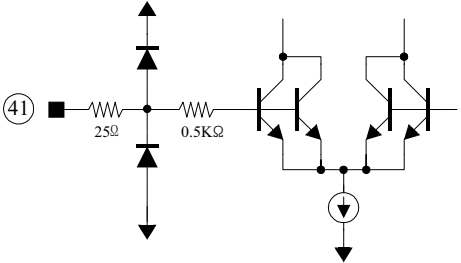
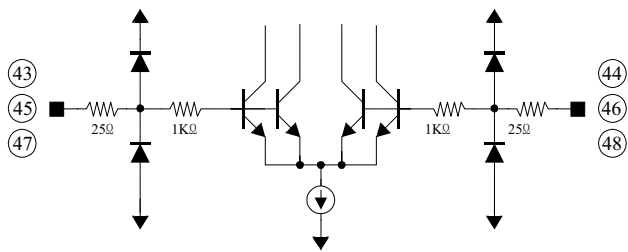
BTL DRIVE OUTPUT	BTL DRIVE MUTE
	
BTL BIAS VOLTAGE	HALL INPUT
	

Absolute Maximum Ratings (Ta=25°C)

Parameter	Symbol	Value	Unit
Supply Voltage (BTL SIGNAL)	VCC1max	15	V
Supply Voltage (SPINDLE SIGNAL)	VCC2max	7	V
Supply Voltage (MOTOR)	VMmax	15	V
Supply Voltage (BTL MOTOR)	VMBTLmax	15	V
Power Dissipation	Pd	3.0 ^{note}	W
Operating Temperature Range	Topr	-35 ~ +85	°C
Storage Temperature Range	Tstg	-55 ~ +150	°C
Maximum Output Current (SPINDLE part)	IOMAXS	1.3	A
Maximum Output Current (BTL part)	IOMAXB	1	A

- NOTE: 1. When mounted on 70mm × 70 mm × 1.6mm PCB (Phenolic resin material)
 2. Power dissipation is reduced 24 mW/°C for using above Ta=25°C
 3. Do not exceed Pd and SOA.

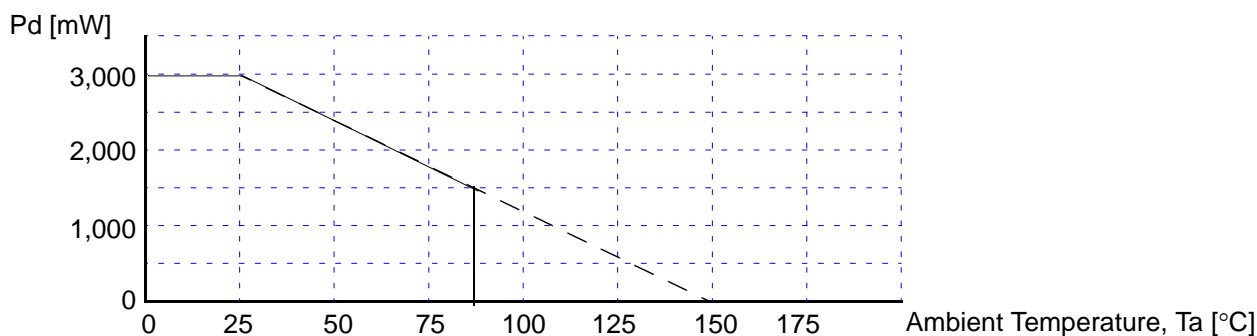

Recommended Operating Conditions (Ta=25°C)

Parameter	Symbol	Min.	Typ.	Max.	Unit
Operating Supply Voltage (BTL SIGNAL)	VCC1	4.5	-	13.2	V
Operating Supply Voltage (SPINDLE SIGNAL)	VCC2	4.5	-	5.5	V
Operating Supply Voltage (SPINDLE MOTOR)	VM	4.5	-	13.2	V
Operating Supply Voltage (BTL MOTOR)	VMBTL	4.5	-	VCC1	V

Electrical Characteristics (Ta=25°C, VCC2=5V, VM=12V)

Parameter	Symbol	Condition	Min.	Typ.	Max.	Unit
Circuit Current 1	ICC 1	Power Save=0V	-	0.3	1	mA
Circuit Current 2	ICC2	Power Save=5V	-	4.5	6	mA
START/STOP						
On Voltage Range	VPSON	L-H Circuit On	2.5	-	-	V
Off Voltage Range	VPSOFF	H-L Circuit Off	-	-	0.5	V
HALL BIAS						
Hall Bias Voltage	VHB	IHB=20mA	-	1.2	1.8	V
HALL AMP						
Hall Bias Current	IHA	-	-	1	5	uA
In-phase in Voltage Range	VHAR	-	1.5	-	4.0	V
Minimum in Level	VINH	-	60	-	-	mVpp
TORQUE CONTROL						
In Voltage Range	EC	-	0.5	-	3.3	V
Offset Voltage (-)	ECOFF-	ECR=2.5V	-100	-50	-20	mV
Offset Voltage (+)	ECOFF+	ECR=2.5V	20	50	100	mV
In Current	ECIN	EC=ECR=2.5V	-5	-1	-	uA
In/output Gain	GEC	ECR=2.5V, RCS=0.5Ω	0.41	0.51	0.61	A / V
FG						
FG Output Voltage (H)	VFGH	IFG= -10uA	3.0	-	VCC	V
FG Output Voltage (L)	VFHL	IFG=10uA	-	-	0.5	V
Input Voltage Range	VFGR	Hn+, Hn- input D-range	1.5	-	4.0	V
OUTPUT BLOCK						
Saturation Voltage (upper TR)	VOH	IO= -300mA	-	0.9	1.6	V
Saturation Voltage (lower TR)	VOL	IO=300mA	-	0.2	0.6	V
Torque Limit Current	ITL	RCS=0.5Ω	560	700	840	mA
DIRECTION DETECTOR						
Dir Output Voltage (H)	VDIRH	IFG=-10uA	3.0	-	VCC	V
Dir Output Voltage (L)	VDIRL	IFG=10uA	-	-	0.5	V
SHORT BRAKE						
On Voltage Range	VSBON	-	2.5	-	VCC	V
Off Voltage Range	VSBOFF	-	0	-	0.5	V

Electrical Characteristics (continued)

BTL Drive Part (Ta=25°C, VCC1=12V, VMBTL=12V, RL=24Ω)

Parameter	Symbol	Condition	Min.	Typ.	Max.	Unit
Quiescent Circuit Current	ICC	-	-	18	25	mA
Output Offset Voltage	VOO	-	-40	-	40	mV
Maximum Output Amplitude Voltage	VOM	-	9.5	10.5	-	V
Voltage Gain	GVC	VIN=0.1Vrms, 1kHz	10.5	12.0	13.5	dB
Ripple Rejection Ratio	RR	VIN=0.1Vrms, 120kHz	-	60	-	dB
Slew Rate	SR	120Hz, 2Vpp	-	1.0	-	V/us
CH Mute Off Voltage	VMOFFCH	pin37, 38, 39 = Variation	-	-	1.0	V
CH Mute On Voltage	VMONCH	pin37, 38, 39 = Variation	2.5	-	-	V
NORMAL OP- AMP						
Input Offset Voltage	VOF	-	-20	-	+20	mV
Input Bias Current	IB1	-	-	-	600	nA
High Level Output Voltage	VOH1	-	11	-	-	V
Low Level Output Voltage	VOL1	-	-	-	0.1	V
Output Sink Current	ISINK	-	10	25	-	mA
Output Source Current	ISOU1	-	5	8	-	mA
Open Loop Voltage Gain	GVO1	f=1kHz, VIN=-75dB	-	75	-	dB
Ripple Rejection Ratio	RR1	f=120Hz, VIN=-20dB	-	65	-	dB
Slew Rate	SR1	f=120Hz, 2Vp-p	-	1	-	V/us
Common Mode Rejection Ratio	CMRR1	f=1kHz, VIN=-20dB	-	80	-	dB

Calculation of Gain & Torque Limit Current

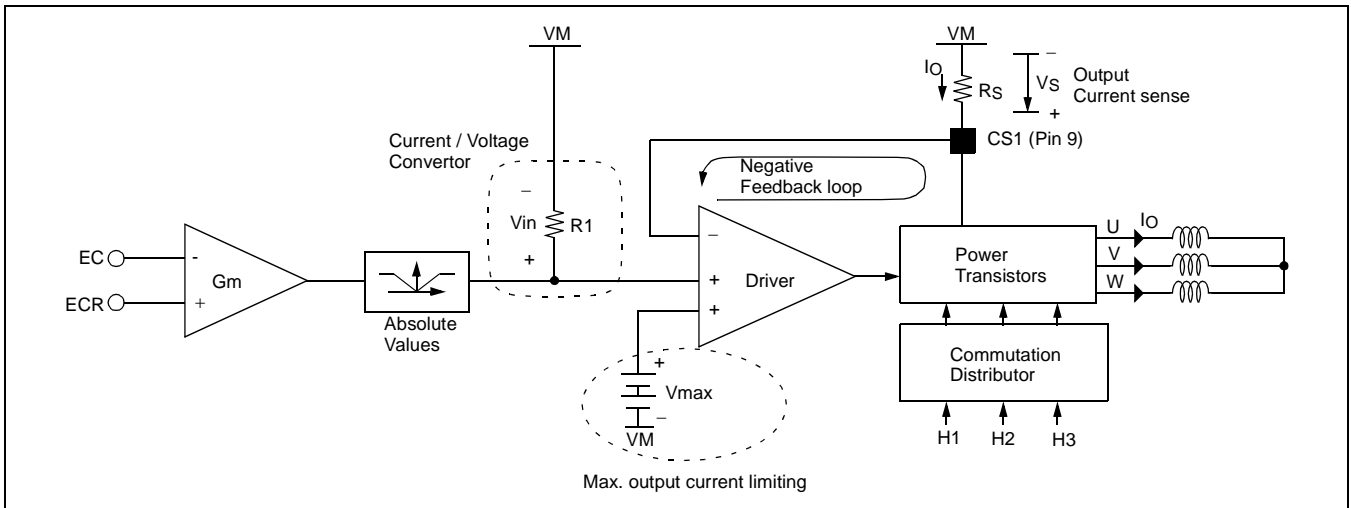

0.255 which is made from GM times R1 is fixed value within IC.

$$\text{Gain} = \frac{0.255}{R_S}$$

Vmax (see above block diagram) is setted to 350mV.

$$|I_t|[\text{mA}] = \frac{V_{\text{max}}}{R_S} = \frac{350[\text{mV}]}{R_S}$$

Application Information

1. Mute Function

1) Mute Control Voltage Condition

When using the mute function, the applied control voltage condition is as follows.

MUTE ON Voltage	2.5[V] above	Mute function operation
MUTE OFF Voltage	OPEN or 0.5[V] below	Normal operation

2) Separated Channel Mute Function

These pins are used for individual channel mute operation.

- When the mute pins (pin 37, 38 and 39) are OPEN or the voltage of the mute pins are below 0.5[V], the mute circuit is stopped and BTL output circuits operate normally.
- When the mute pins (pin 37, 38 and 39) are above 2.5[V], the mute circuits are activated so that the BTL output circuits will be muted.
- If the junction temperature rises above 165°C, then the thermal shutdown (TSD) circuit is activated and all the output circuits (4-CH BTL Drivers and 3-phase BLDC Driver) are muted.

2. 4-CH Balanced Transformerless (Btl) Driver

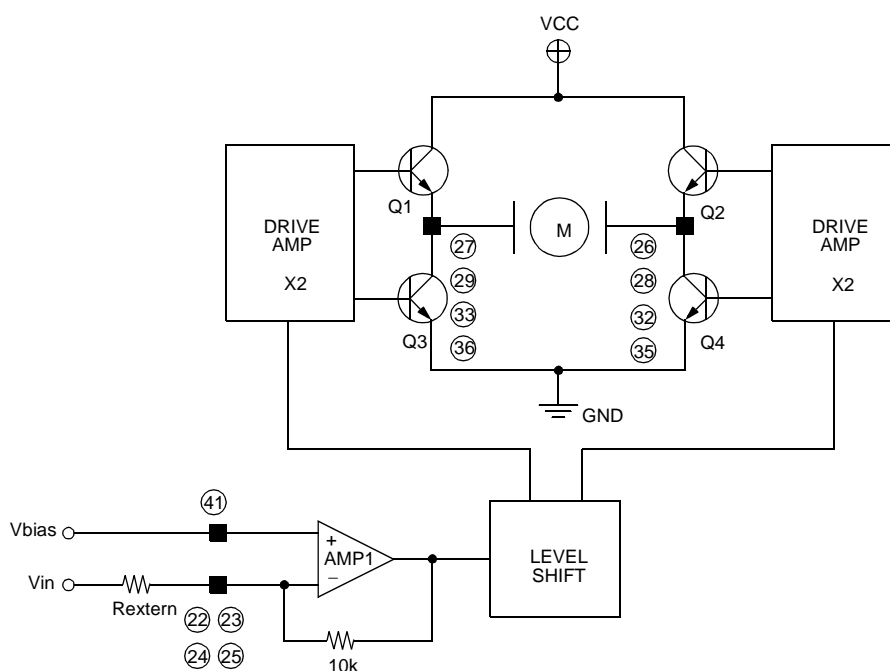

- The voltage, V_{bias} , is the reference voltage given by the external bias voltage of pin 41.
- The input signals, V_{in} , through the pins (pin 22, 23, 24 and 25) are amplified 10K/ R_{extern} times and then fed to the level shift.
- The level shift produces the current due to the difference between the input signal (V_{in}) and the arbitrary reference voltage (V_{bias}). The current produced as $+\Delta I$ and $-\Delta I$ are fed into the drive buffers.
- The drive buffer operates the power TR of the output stage according to the state of the input signal (V_{in}).
- The output stage is the BTL driver, and the motor (or actuator) is rotating in forward direction by operating TR Q1 and TR Q4. On the other hand, if TR Q2 and TR Q3 are operating, the motor (or actuator) is rotating in reverse direction.
- When the input signal V_{in} , through the pin (pin 22, 23, 24 and 25) is below the V_{bias} , then the motor (actuator) is in forward direction.

- When the input signal V_{in} , through the pin (pin 22, 23, 24 and 25) is above the V_{bias} , then the motor (actuator) is in reverse direction.
- If you want to change the gain, then modify the external resistor's value (R_{extern})

3. Torque & Output Current Control

Torque Control & Output Current Control

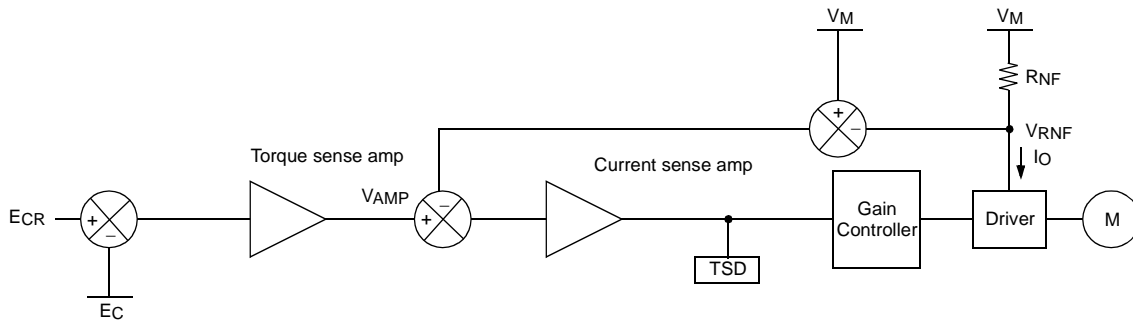

- By amplifying the voltage difference between E_C and E_{CR} from the Servo IC, the torque sense AMP produces the input (V_{AMP}) for the current sense AMP.
- The current sense AMP produces the input for the Gain controller to allow the output current (I_O) of the driver to be controlled by the input voltage (V_{AMP}), where the output current (I_O) is detected by the sense resistor (R_{NF}) and is converted into V_{RNF} .
- In the end, the signals of the Servo IC control the velocity of the motor by controlling the output current (I_O) of the driver.
- When the junction temperature rises up to about $165^{\circ}C$, then the output drive circuit will be shut down.
- The range of the torque control input voltage is as shown below.

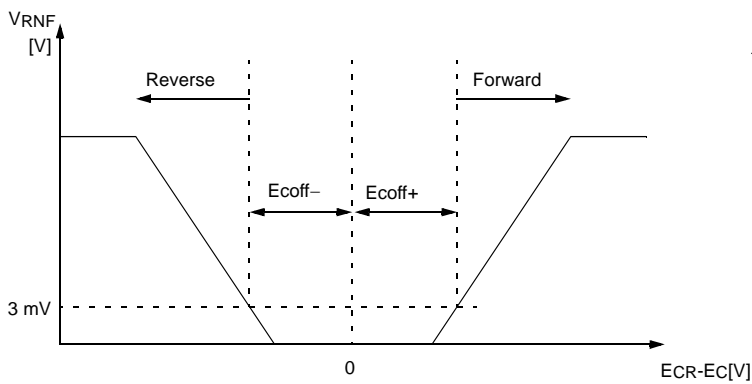

	Rotation
$E_c < E_{CR}$	Forward rotation
$E_c > E_{CR}$	Stop after detecting reverse rotation

The input range (E_C) of the Torque Sense AMP is $0.5V \sim 3.3V$

4. Power Save Function

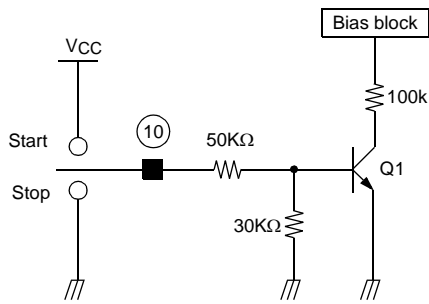

- This function block operates the power saving function.
- The power save circuit is activated by operating TR Q1.
- When the SS (Start/Stop) pin 10 is high (VCC), the TR Q1 is turned on so that the bias circuit is enabled. On the other hand, when the SS (Start/Stop) pin 10 is Open or Low (GND), the TR Q1 is turned off so that the bias circuit is disabled.
- The power save operation controlled by SS (pin 10) input conditions is as follows;

Pin#10	FAN8727
HIGH	START
OPEN/LOW	STOP

5. Short Brake Function

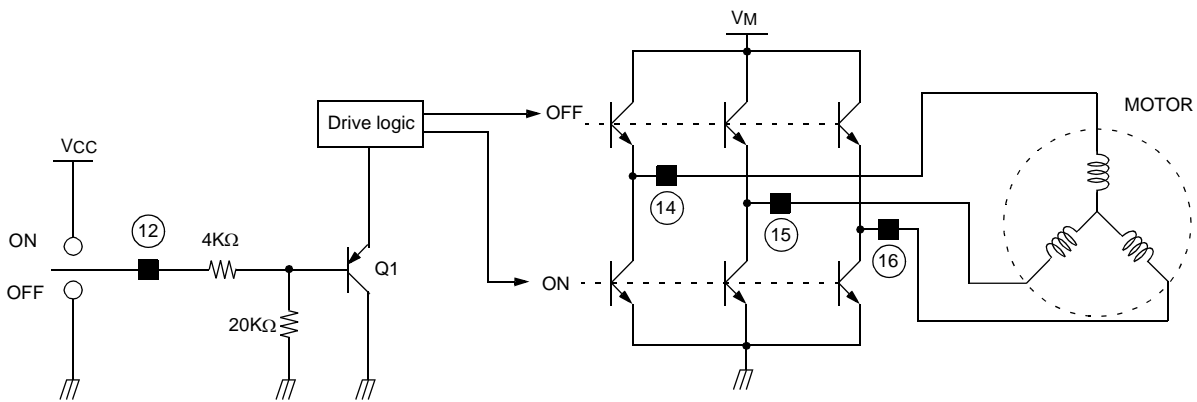

When the pick-up part moves from the inner to the outer spindle of the MD, the brake function of the reverse voltage is commonly employed to rate the rotational velocity of the spindle motor. However, if the spindle motor rotates rapidly, the brake function of the reverse voltage may produce too much heat at the drive IC.

To remove these shortcomings and to enhance efficiency, the short brake function is added to FAN8727. When the short brake function is active, all upper Power transistors are turned off and the lower Power transistors turned on, so as to reduce the rotational velocity of the motor. The short brake operation controlled by SB (pin 12), and the inputs conditions are as follows.

Pin#12	SHORT BRAKE
HIGH	ON
LOW	OFF

6. Thermal Shutdown (Tsd) Function

When the junction temperature rises up to about 165°C, then the output drive circuit is shut down, when the junction temperature falls off to about 140°C, the output drive circuit will be normally operated. It has the temperature hysteresis of about 25°C.

7. Rotational Direction Detecting Function

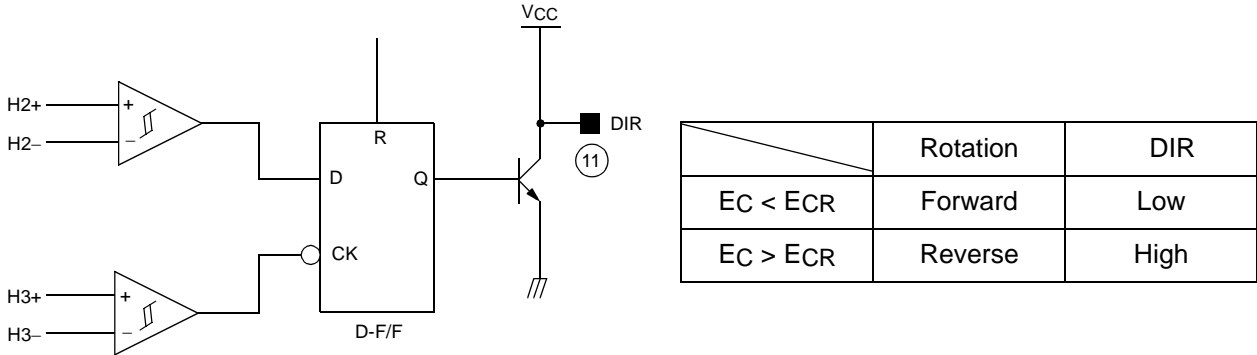

- The forward and reverse rotations of the MD are detected by the circuit, as shown in the above Table.
- The rotational direction of the MD can be learned by the output waveforms of the hall sensor and/or the driver. Let the three hall sensors be H1, H2 and H3 respectively. If the hall sensors turn on in the order, H1 → H2 → H3, of the reverse rotation, the output waveforms of the hall sensors will be as shown below.

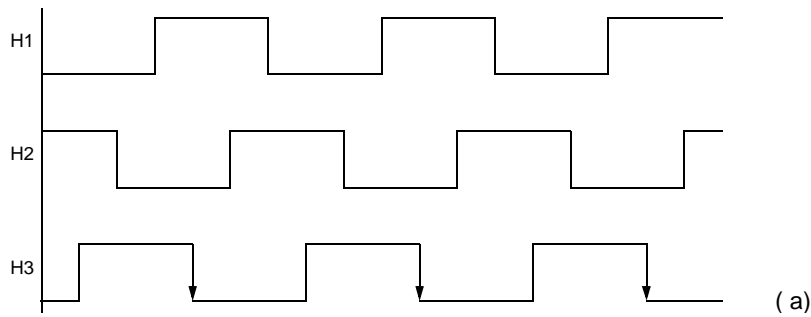

Inversely, if the hall sensors turn on in the order, H3 → H2 → H1, of the forward rotation, the output waveforms of the hall sensors will be as shown next page.

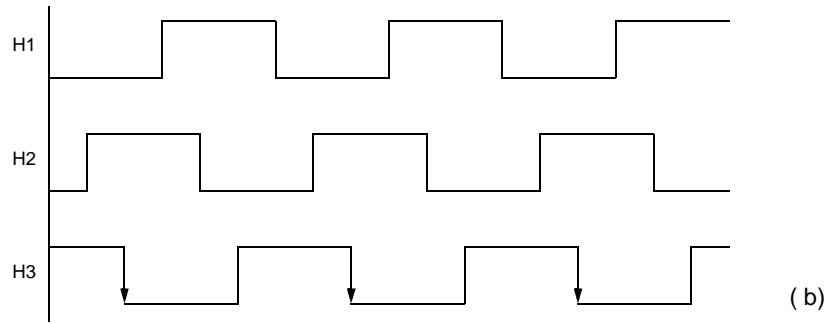

In the cases above, the value of H2 at the falling edges of H3 is Low in figure <a>, while High in figure . The rotational direction detector takes advantage of this phenomenon.

8. Reverse Rotation Preventing Function

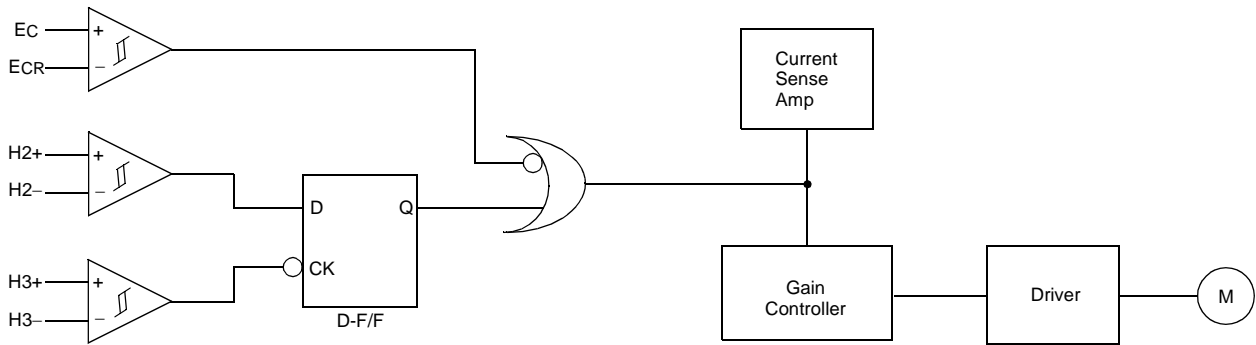

- The forward and reverse rotation of the motor are detected, as shown in the table below, by the circuit shown above. Consequently at reverse rotation, the D-F/F output Q becomes Low and cuts off the output current sense Amp, resulting in the stoppage of the Gain controller function.
- When the MD is rotating in forward direction, $EC > ECR$ is sometimes controlled to retard and/or stop the MD. As the controlling time of $EC > ECR$ gets longer, MD slows down, stops, and then rotates in the reverse direction. To prevent the MD from rotating in the reverse direction, a reverse rotation resistant function is required. Its operational principles are discussed below.

Rotation	H2	H3	D-F/F	Reverse Rotation Preventer	
				$EC < ECR$	$EC > ECR$
Forward	H	$H \rightarrow L$	H	Forward	Brake and Stop
Reverse	L	$H \rightarrow L$	L	-	Stop

9. Fg Output Function

The FG output, which detects the number of rotations of the MD, is generated by combination zero-crossing the output waveforms of the hall sensors. The FG output circuit is as shown below.

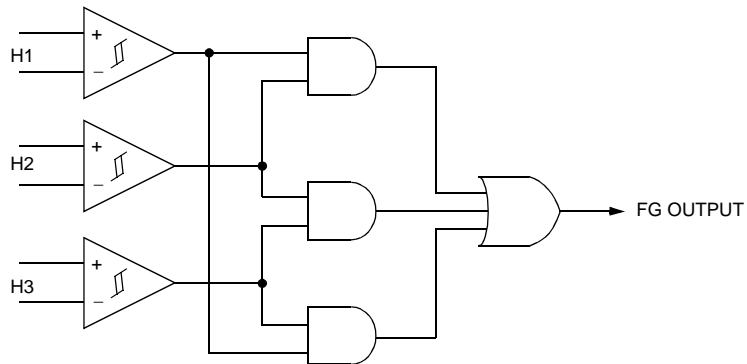

10. Hall Sensor Connection

External Hall sensors are used in series or parallel connection as shown below.

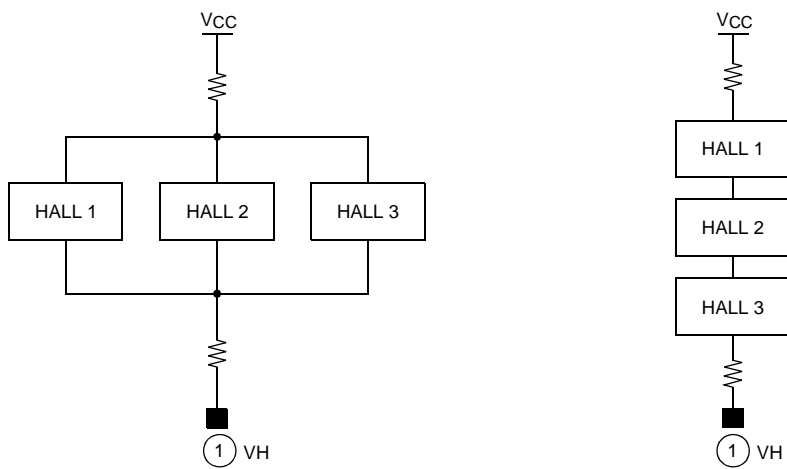

11. Hall Input Output Timing Chart

The 3-phase hall signal is amplified in the hall amplifiers and sent to the matrix section, where the signal is further amplified and combined. After the signal is converted to a current in the amplitude control circuit, the current is supplied to the output driver, which then provides a motor drive current. The phases of the hall input signal, output voltage, and output current are shown below.

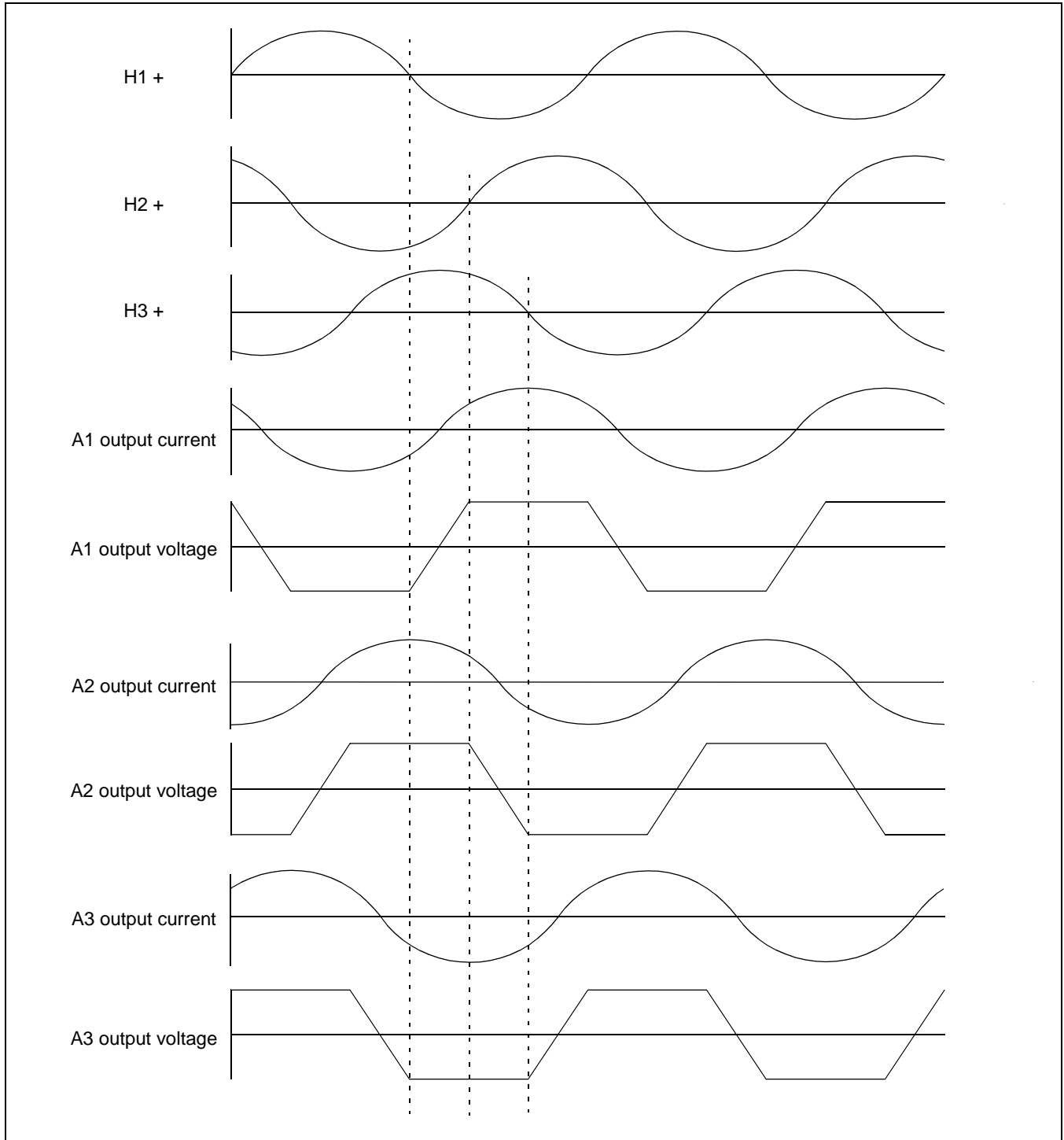

12. Power Supply Sequence

VM must be supplied faster than VCC2,

Test Circuits 1

BTL Drive Part

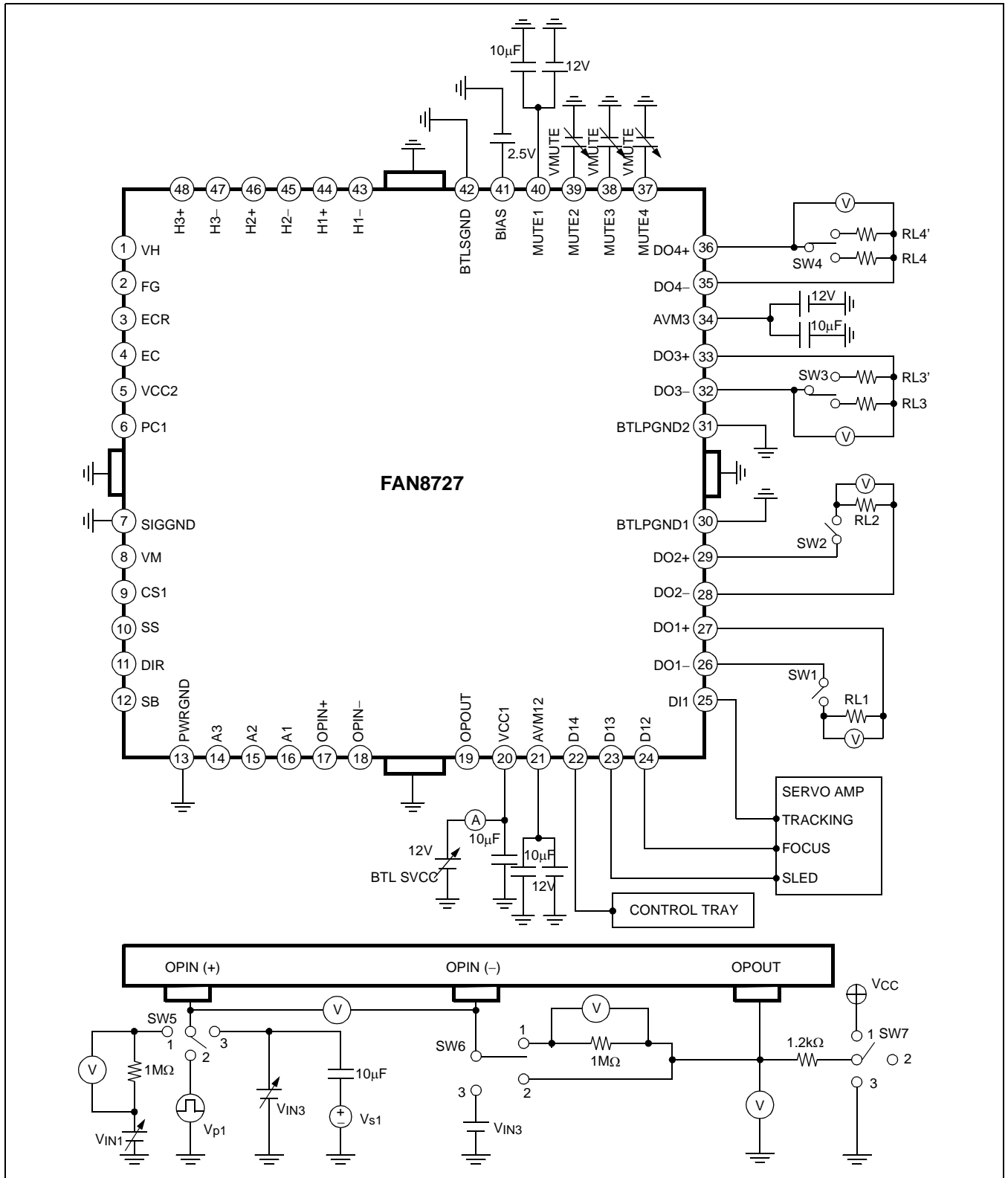

Test Circuits 2

Spindle Motor Drive Part

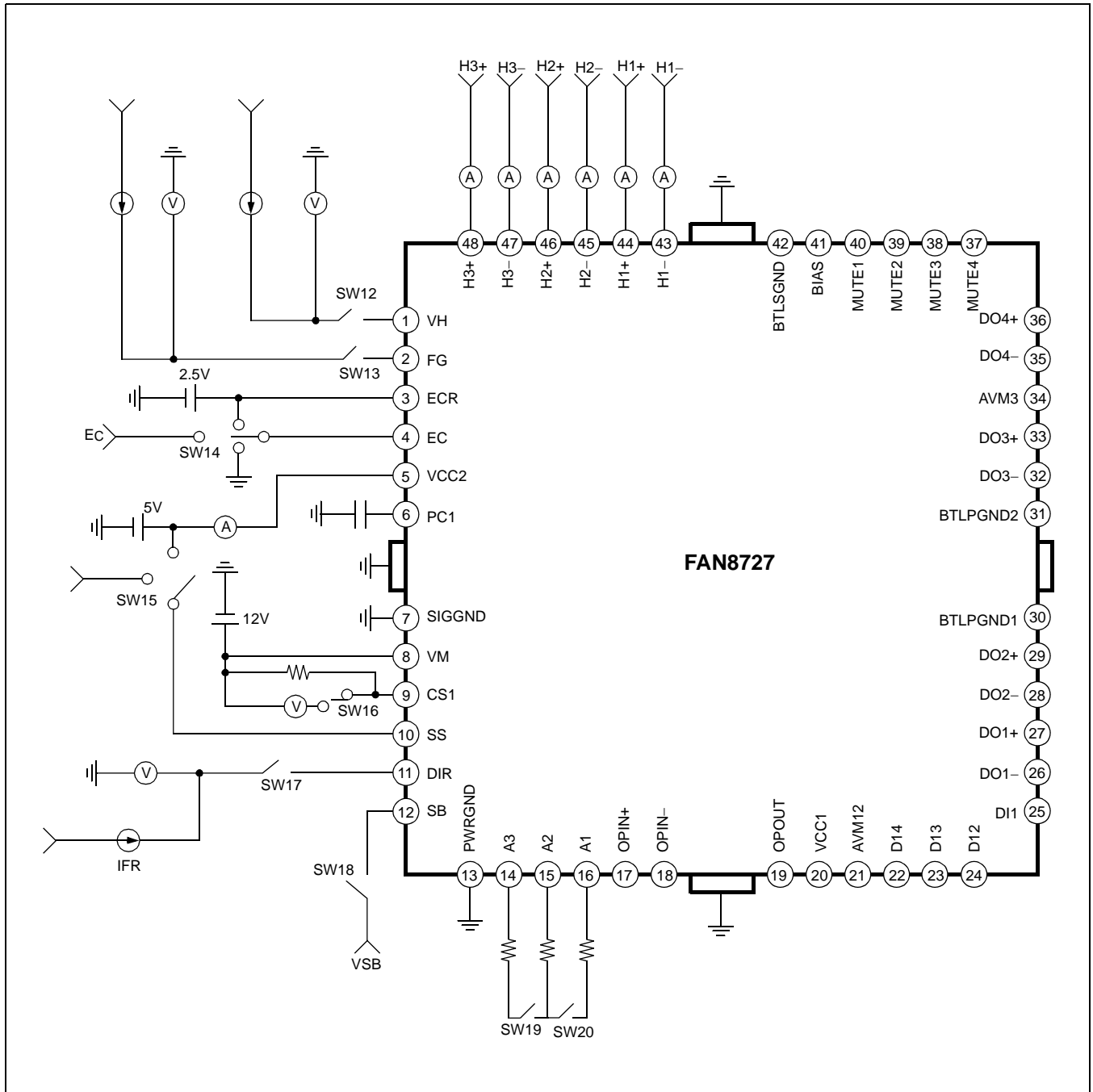

Application Circuits

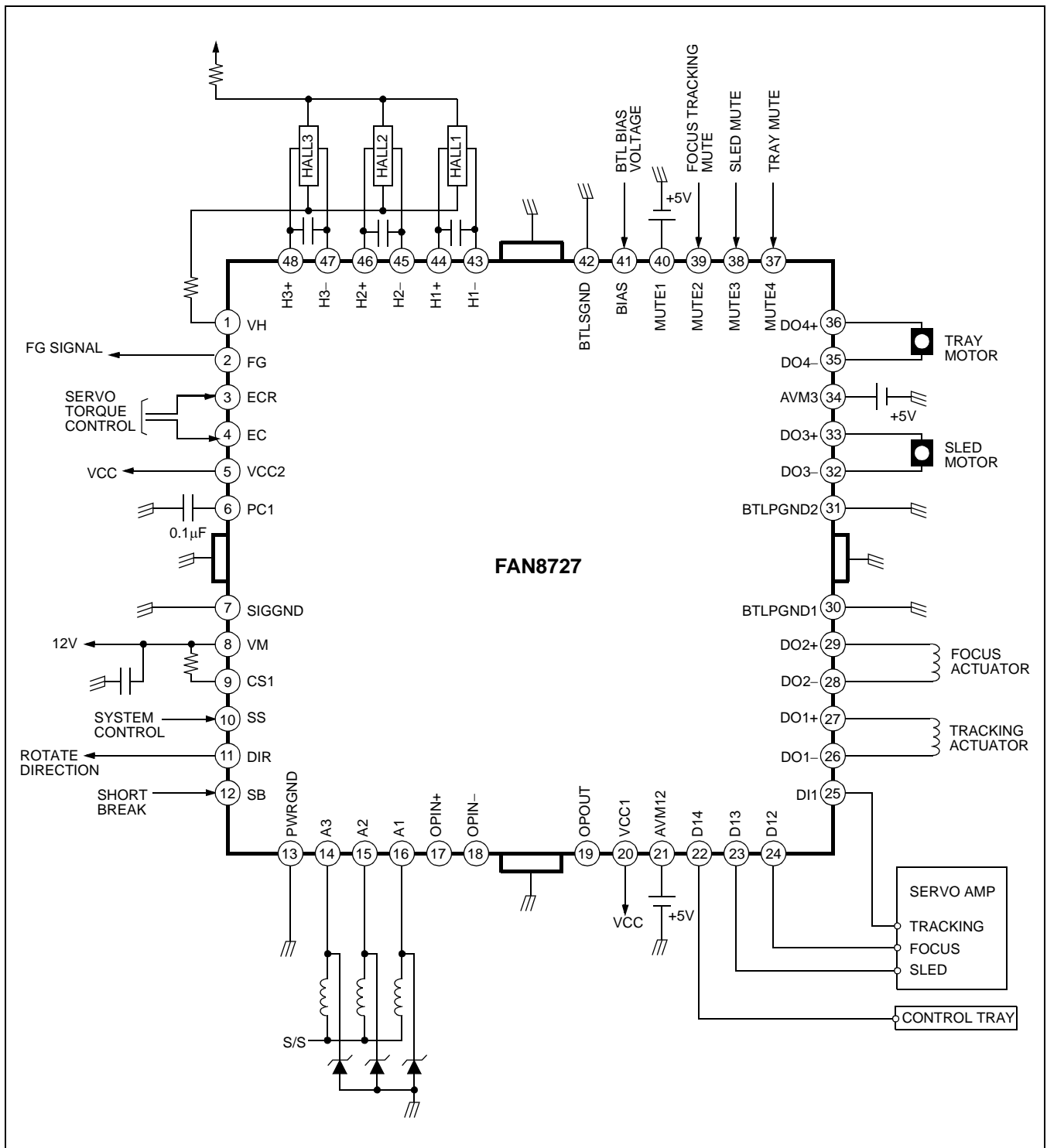

DISCLAIMER

FAIRCHILD SEMICONDUCTOR RESERVES THE RIGHT TO MAKE CHANGES WITHOUT FURTHER NOTICE TO ANY PRODUCTS HEREIN TO IMPROVE RELIABILITY, FUNCTION OR DESIGN. FAIRCHILD DOES NOT ASSUME ANY LIABILITY ARISING OUT OF THE APPLICATION OR USE OF ANY PRODUCT OR CIRCUIT DESCRIBED HEREIN; NEITHER DOES IT CONVEY ANY LICENSE UNDER ITS PATENT RIGHTS, NOR THE RIGHTS OF OTHERS.

LIFE SUPPORT POLICY

FAIRCHILD'S PRODUCTS ARE NOT AUTHORIZED FOR USE AS CRITICAL COMPONENTS IN LIFE SUPPORT DEVICES OR SYSTEMS WITHOUT THE EXPRESS WRITTEN APPROVAL OF THE PRESIDENT OF FAIRCHILD SEMICONDUCTOR CORPORATION. As used herein:

1. Life support devices or systems are devices or systems which, (a) are intended for surgical implant into the body, or (b) support or sustain life, and (c) whose failure to perform when properly used in accordance with instructions for use provided in the labeling, can be reasonably expected to result in a significant injury of the user.
2. A critical component in any component of a life support device or system whose failure to perform can be reasonably expected to cause the failure of the life support device or system, or to affect its safety or effectiveness.



LittleDiode supplies new, hard to find or obsolete electronic components and semiconductors all over the world.

With over two million different components listed you are sure to find the part you need.

Feel free to visit us today at our online store:

LittleDiode.com

Looking forward to providing you with the best possible service.