

FAN8728

Spindle + 4-CH Input PWM Motor Drive IC

Features

- Built-in Power Save Circuit
- Built-in Current Limit Circuit
- Built-in Thermal Shutdown Circuit (TSD)
- Built-in FG Signal Output Circuit
- Built-in Rotational Direction Detecting Circuit
- Built-in Protection Circuit For Reverse Rotation
- Built-in 4-CH Balanced Transformerless (BTL) Driver
- Built-in BTL MUTE Circuit (CH1-2, CH3 and CH4)
- Corresponds to 3.3V DSP

Description

The FAN8728 is a monolithic integrated circuit suitable for a 4-ch motor driver which drives the tracking actuator, focus actuator, sled motor, loading motor and 3-phase BLDC spindle motor of the MDP/CAR-MD/CAR-NAVIGATION system.

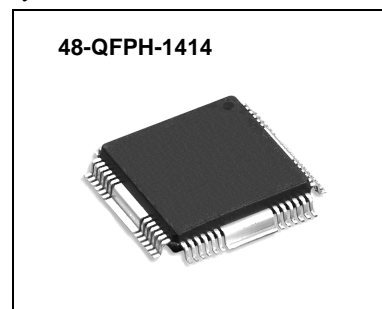

Typical Applications

- Mini Disk Player
- Digital Video Disk Player
- Car Mini Disk Player
- Car Navigation System

Ordering Information

Device	Package	Operating Temp
FAN8728	48-QFPH-1414	-35°C ~ 85°C

Pin Assignments

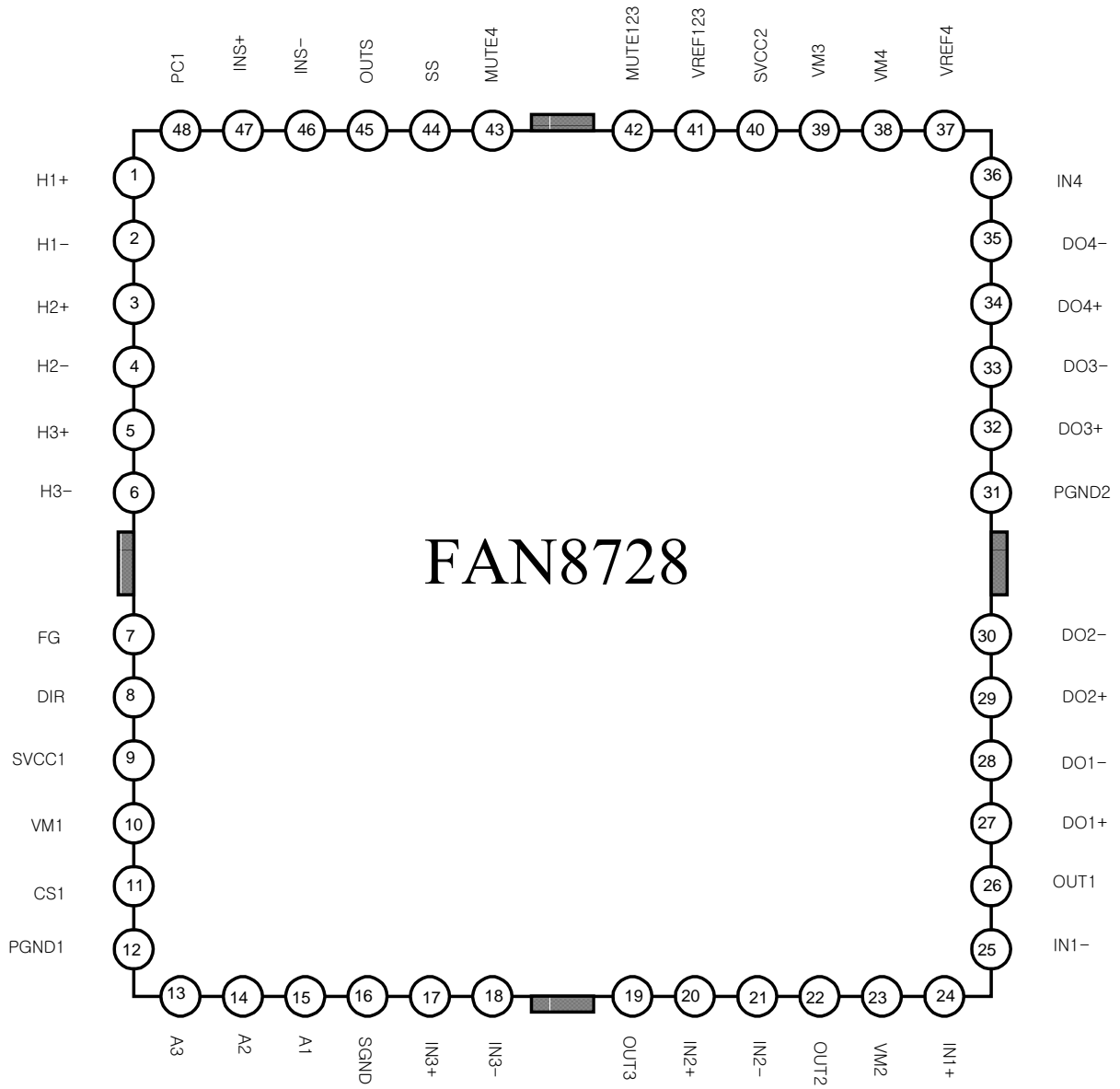

Pin Definitions

Pin Number	Pin Name	I/O	Pin Function Description
1	H1+	I	Hall1(+) Input
2	H1-	I	Hall1(-) Input
3	H2+	I	Hall2(+) Input
4	H2-	I	Hall2(-) Input
5	H3+	I	Hall3(+) Input
6	H3-	I	Hall3(-) Input
7	FG	O	FG Output
8	DIR	O	Direction
9	SVCC1	-	SIGNAL VCC1
10	VM1	-	Motor Power Supply
11	CS1	I	Current Sensor
12	PGND1	-	Power Ground
13	A3	O	3-Phase Output 3
14	A2	O	3-Phase Output 2
15	A1	O	3-Phase Output 1
16	SGND	-	Signal Ground
17	IN3+	I	Op-amp CH3 Input(+)
18	IN3-	I	Op-amp CH3 Input(-)
19	OUT3	O	Op-amp CH3 Output
20	IN2+	I	Op-amp CH2 Input(+)
21	IN2-	I	Op-amp CH2 Input(-)
22	OUT2	O	Op-amp CH2 Output
23	VM2	-	BTL CH1,2 Supply Voltage
24	IN2+	I	Op-amp CH2 Input(+)
25	IN2-	I	Op-amp CH2 Input(-)
26	OUT2	O	Op-amp CH2 Output
27	DO1+	O	BTL Drive 1 Output(+)
28	DO1-	O	BTL Drive 1 Output(-)
29	DO2+	O	BTL Drive 2 Output(+)
30	DO2-	O	BTL Drive 2 Output(-)
31	PGND2	-	BTL Power Gnd
32	DO3+	O	BTL Drive 3 Output(+)
33	DO3-	O	BTL Drive 3 Output(-)

Pin Definitions (Continued)

Pin Number	Pin Name	I/O	Pin Function Description
34	DO4+	O	BTL Drive 4 Output(+)
35	DO4-	O	BTL Drive 4 Output(-)
36	IN4	I	BTL CH4 Input
37	VREF4	I	BTL CH4 Reference
38	VM4	-	BTL CH4 Motor Supply
39	VM3	-	BTL CH3 Motor Supply
40	SVCC2	-	BTL Signal VCC
41	VREF123	I	BTL CH1,2,3 Rference
42	MUTE123	I	BTL CH1,2,3 Mute
43	MUTE4	I	BTL CH4 Mute
44	SS	I	Spindle Start/Stop
45	OUTS	O	Opamp Spindle Output
46	INS-	I	Opamp Spindle Input(-)
47	INS+	I	Opamp Spindle Input(+)
48	PC1	I	Phase Compesation Cap.

Internal Block Diagram

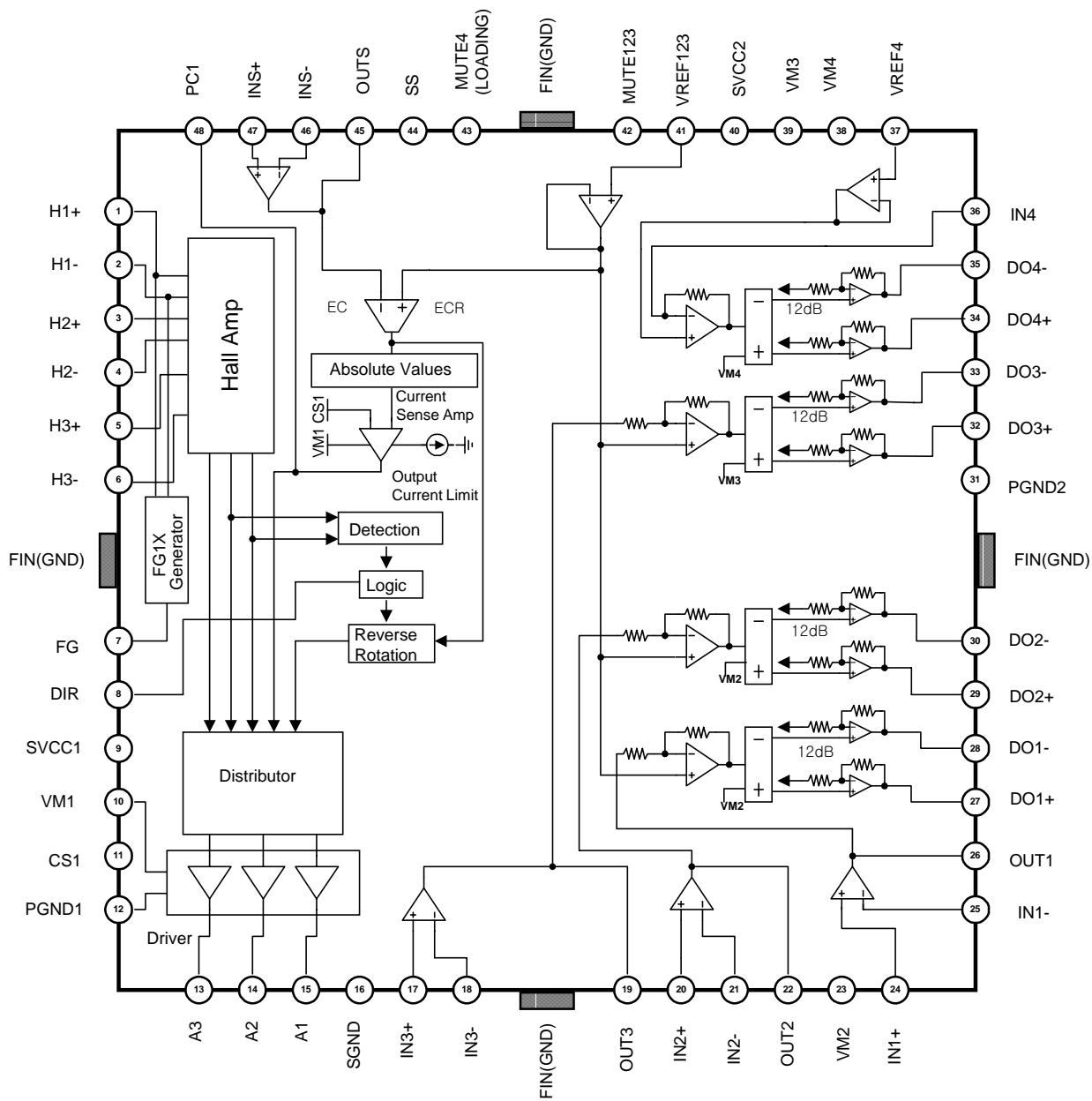

Equivalent Circuits

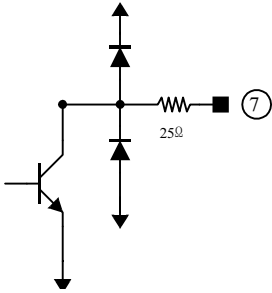
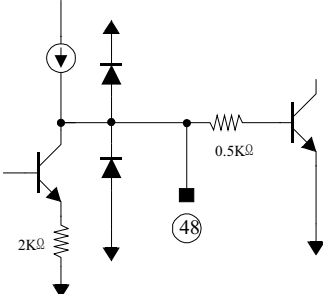
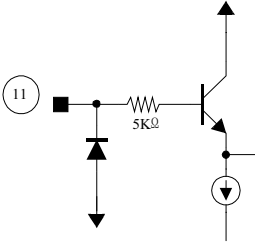
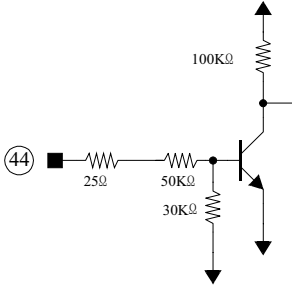
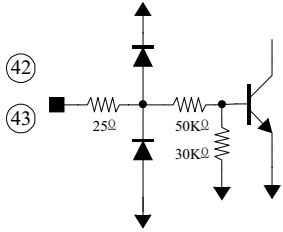
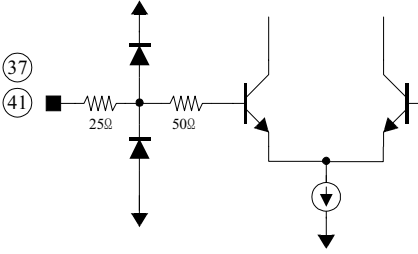
FG Signal Output	Phase Compensation Capacitor
	
Current Detector	Start/Stop
	
BTL Drive Mute	BTL Bias Voltage
	

Equivalent Circuits (Continued)

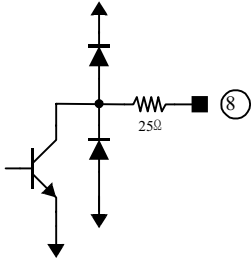
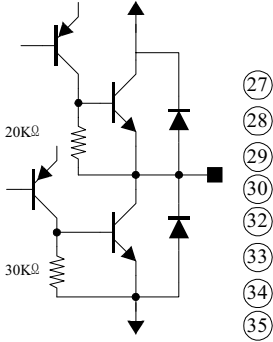
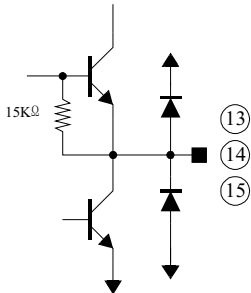
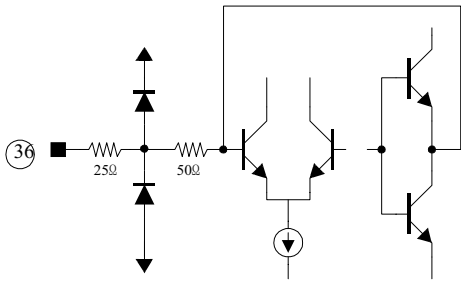
3-Phase Rotational Direction Output	BTL Drive Output
	
3-Phase Output	BTL Drive Input
	

Absolute Maximum Ratings (Ta=25°C)

Parameter	Symbol	Value	Unit
Supply Voltage (BTL Signal)	SVCC2max	15	V
Supply Voltage (Spindle Signal)	SVCC1max	7	V
Supply Voltage (Motor)	VMmax	15	V
Supply Voltage (BTL Motor)	VM2,3,4max	15	V
Power Dissipation	Pd	2.7 ^{note}	W
Operating Temperature Range	Topr	-35 ~ +85	°C
Storage Temperature Range	Tstg	-55 ~ +150	°C
Maximum Output Current (Spindle Part)	IOMAXS	1.3	A
Maximum Output Current (BTL Part)	IOMAXB	1	A

Note :

1. When mounted on 70mm × 1.6mm PCB (Phenolic resin material)
2. Power dissipation is reduced 21.6mW/°C for using above Ta = 25°C
3. Do not exceed Pd and SOA.

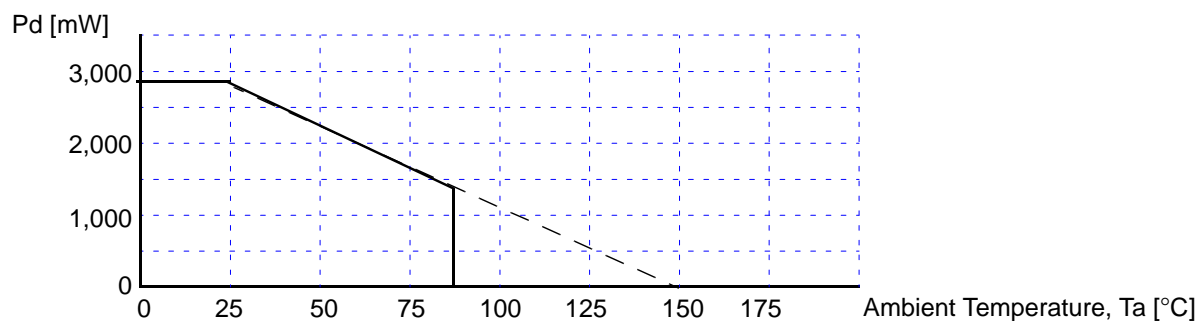

Recommended Operating Conditions (Ta=25°C)

Parameter	Symbol	Min.	Typ.	Max.	Unit
Operating Supply Voltage (BTL Signal)	SVCC2	4.5	-	13.2	V
Operating Supply Voltage (Spindle Signal)	SVCC1	4.5	-	5.5	V
Operating Supply Voltage (Spindle Motor)	VM1	4.5	-	13.2	V
Operating Supply Voltage (BTL Motor)	VM2,3,4	4.5	-	13.2	V

Electrical Characteristics

(Ta=25°C, SVCC1=5V, VM1=8V)

Parameter	Symbol	Condition	Min.	Typ.	Max.	Unit
Circuit Current 2	ICC2	Start/Stop =5V	-	6	-	mA
START/STOP						
SS On Voltage Range	VSSON	L-H Circuit On	2.5	-	-	V
SS Off Voltage Range	VSSOFF	H-L Circuit Off	-	-	1.0	V
HALL AMP						
Hall Bias Current	IHA	-	-	1	5	uA
In-phase in Voltage Range	VHAR	-	1.5	-	4.0	V
Minimum in Level	VINH	-	60	-	-	mVpp
TORQUE CONTROL						
Offset Voltage (-)	ECOFF-	ECR=1.65V	-100	-50	-20	mV
Offset Voltage (+)	ECOFF+	ECR=1.65V	20	50	100	mV
In/output Gain	GEC	ECR=1.65V, RCS=0.5Ω	0.56	0.71	0.84	A / V
FG						
FG Output Voltage (L)	VFHL	IFG=10uA	-	-	0.5	V
Input Voltage Range	VFGR	Hn+, Hn- input D-range	1.5	-	4.0	V
OUTPUT BLOCK						
Saturation Voltage (upper TR)	VOH	IO= -300mA	-	0.9	1.6	V
Saturation Voltage (lower TR)	VOL	IO=300mA	-	0.2	0.6	V
Torque Limit Current	ITL	RCS=0.5Ω	560	700	840	mA
DIRECTION DETECTOR						
Dir Output Voltage (L)	VDIRL	IFG=10uA	-	-	0.5	V

Electrical Characteristics (continued)

BTL Drive Part (Ta=25°C, SVCC2=8V, VM2,3,4=8V, RL=24Ω)

Parameter	Symbol	Condition	Min.	Typ.	Max.	Unit
BTL DRIVE PART						
Quiescent Circuit Current	ICC3	-	-	20	-	mA
CH Mute123 Off Voltage	VMOFF123	pin42= Variation	-	-	1.0	V
CH Mute123 On Voltage	VMON123	pin42 = Variation	2.5	-	-	V
CH Mute4 Off Voltage	VMOFF4	pin43 = Variation	-	-	1.0	V
CH Mute4 On Voltage	VMON4	pin43 = Variation	2.5	-	-	V
CH1,2,3(SVCC2=8V VM2=5V,RL=8Ω)						
Output Offset Voltage	VOF1,2,3	-	-50	-	+50	mV
Maximum Output Voltage1,2,3	VOM1,2,3	-	3.6	4.0	-	V
Close Loop Voltage Gain	GVC1,2,3	f=1kHz, VIN=-0.1Vrms	10.5	12.0	13.5	dB
Ripple Rejection Ratio	RR1,2,3	f=120Hz, VIN=-20dB	-	60	-	dB
Slew Rate 1,2,3	SR1,2,3	f=120Hz, 2Vp-p	-	1.0	-	V/us
CH4(SVCC2=8V VM4=8V,RL=12Ω)						
Output Offset Voltage4	VOF4	-	-50	-	+50	mV
Maximum Output Voltage4	VOM4	-	6.0	6.5	-	V
Close Loop Voltage Galin	GVC4	f=1kHz, VIN=-0.1Vrms	10.5	12.0	13.5	dB
Ripple Rejection Ratio4	RR4	f=120Hz, VIN=-20dB	-	60	-	dB
Slew Rate 4	SR4	f=120Hz, 2Vp-p	-	1.0	-	V/us
OP- AMP						
Input Offset Voltage	VOF	-	-20	-	+20	mV
Input Bias Current	IB1	-	-	-	300	nA
High Level Output Voltage	VOHOP	-	11	-	-	V
Low Level Output Voltage	VOLOP	-	-	-	0.1	V
Output Sink Current	ISINK	-	-	5.5	-	mA
Output Source Current	ISOURCE	-	-	4.5	-	mA
Open Loop Voltage Gain	GVOOP	f=1kHz, VIN=-75dB	-	75	-	dB
Ripple Rejection Ratio	RROP	f=120Hz, VIN=-20dB	-	65	-	dB
Slew Rate	SROP	f=120Hz, 2Vp-p	-	1	-	V/us
Common Mode Rejection Ratio	CMRROP	f=1kHz, VIN=-20dB	-	80	-	dB

Calculation of Gain & Torque Limit Current

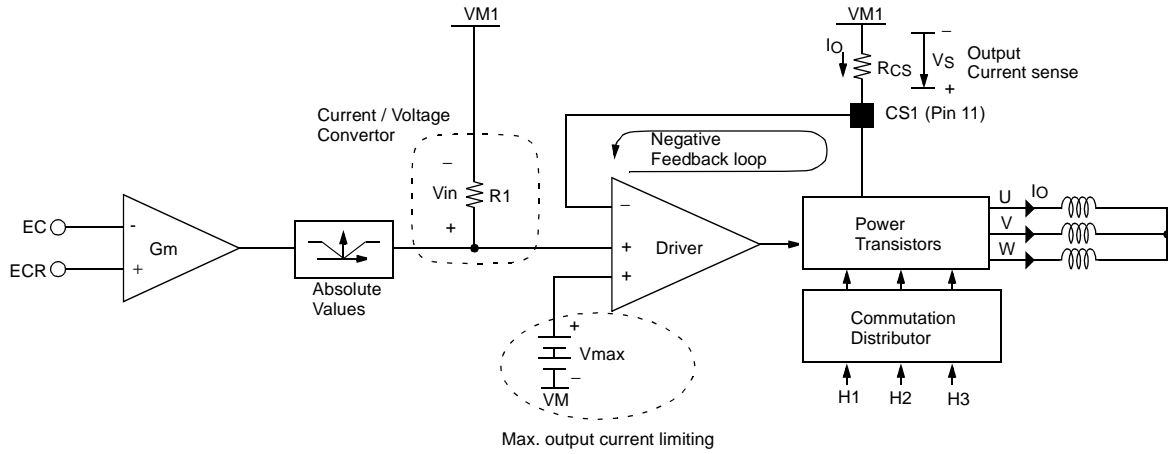

0.355 which is made from GM times R1 is fixed value within IC.

$$\text{Gain} = \frac{0.355}{R_{CS}}$$

Vmax (see above block diagram) is setted to 350mV.

$$I_{t}[mA] = \frac{V_{max}}{R_{CS}} = \frac{350[mV]}{R_{CS}}$$

Application Information

1. Mute Function

1) Mute Control Voltage Condition

When using the mute function, the applied control voltage condition is as follows.

MUTE123,4 ON Voltage	2.5[V] above	Mute function operation
MUTE123,4 OFF Voltage	OPEN or 0.5[V] below	Normal operation

2) Separated Channel Mute Function

These pins are used for individual channel mute operation.

- When the mute pins are OPEN or the voltage of the mute pins are below 1[V], the mute circuit is stopped and BTL output circuits operate normally.
- When the mute pins are above 2.5[V], the mute circuits are activated so that the BTL output circuits will be muted.
- If the junction temperature rises above 165°C, then the thermal shutdown (TSD) circuit is activated and all the output circuits (4-CH BTL Drivers and 3-phase BLDC Driver) are muted.

3) FG and Dir Signal.

- FG and DIR signal is independent to SS(pin44) input.

2. CH1,2,3 Balanced Transformerless (BTL) Drive (Error Amp Included)

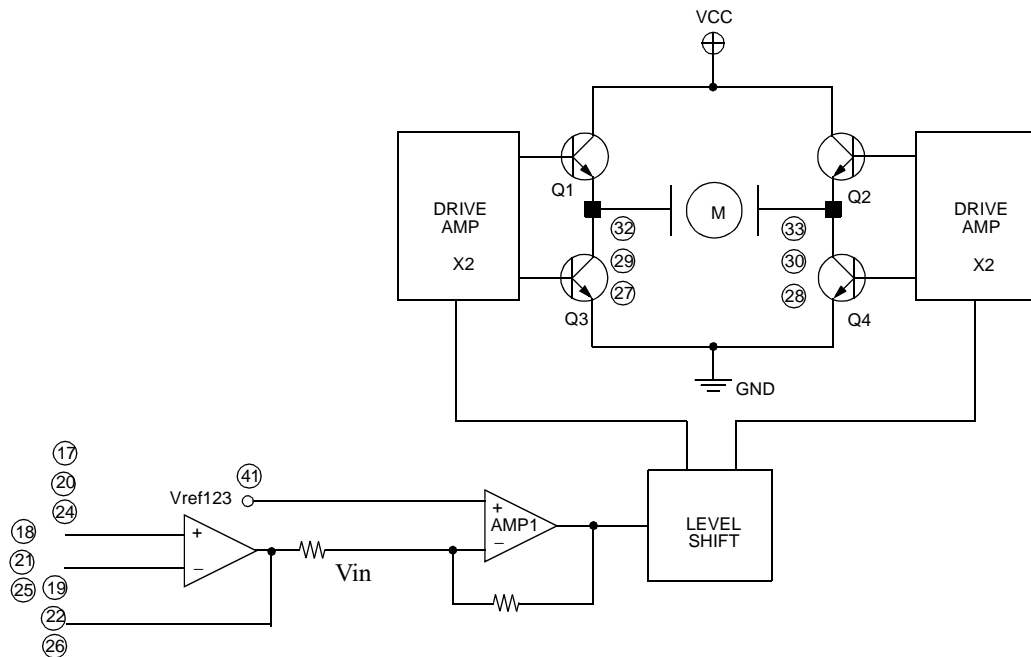

- The voltage, V_{bias} , is the reference voltage given by the external bias voltage of pin 41..
- The level shift produces the current due to the difference between the input signal (V_{in}) and the arbitrary reference voltage (V_{bias}). The current produced as $+\Delta I$ and $-\Delta I$ are fed into the drive buffers.
- The drive buffer operates the power TR of the output stage according to the state of the input signal.
- The output stage is the BTL driver, and the motor (or actuator) is rotating in forward direction by operating TR Q1 and TR Q4. On the other hand, if TR Q2 and TR Q3 are operating, the motor (or actuator) is rotating in reverse direction.
- V_{in} is below the V_{bias} , then the motor (actuator) is in forward direction.

3. CH4 Balanced Transformerless (BTL) Driver

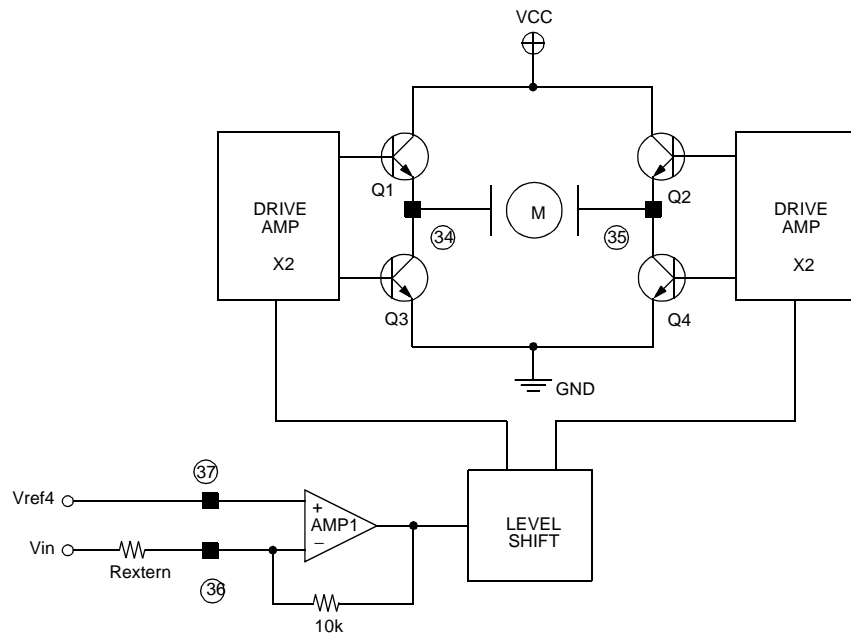

- The voltage, V_{bias} , is the reference voltage given by the external bias voltage of pin 37.
- The input signals, V_{in} , through the pins (pin 36) are amplified $10K/R_{extern}$ times and then fed to the level shift.
- The level shift produces the current due to the difference between the input signal (V_{in}) and the arbitrary reference voltage (V_{bias}). The current produced as $+\Delta I$ and $-\Delta I$ are fed into the drive buffers.
- The drive buffer operates the power TR of the output stage according to the state of the input signal (V_{in}).
- The output stage is the BTL driver, and the motor is rotating in forward direction by operating TR Q1 and TR Q4. On the other hand, if TR Q2 and TR Q3 are operating, the motor is rotating in reverse direction.
- When the input signal V_{in} , through the pin (pin 36) is below the V_{bias} , then the motor is in forward direction.
- When the input signal V_{in} , through the pin (pin 36) is above the V_{bias} , then the motor is in reverse direction.
- If you want to change the gain, then modify the external resistor's value (R_{extern})

4. Torque & Output Current Control

Torque Control & Output Current Control

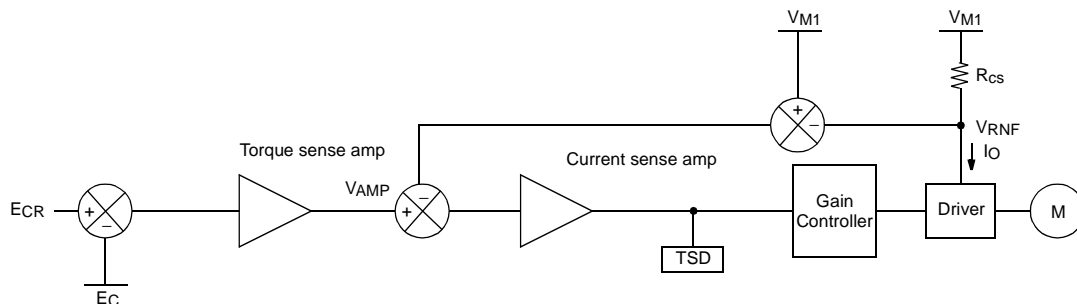

- By amplifying the voltage difference between EC and ECR from the Servo IC, the torque sense AMP produces the input (V_{AMP}) for the current sense AMP.
- The current sense AMP produces the input for the Gain controller to allow the output current (I_O) of the driver to be

controlled by the input voltage (V_{AMP}), where the output current (I_O) is detected by the sense resistor (R_{NF}) and is converted into V_{RNF} .

- In the end, the signals of the Servo IC control the velocity of the motor by controlling the output current (I_O) of the driver.
- When the junction temperature rises up to about 165°C , then the output drive circuit will be shut down.
- The range of the torque control input voltage is as shown below.

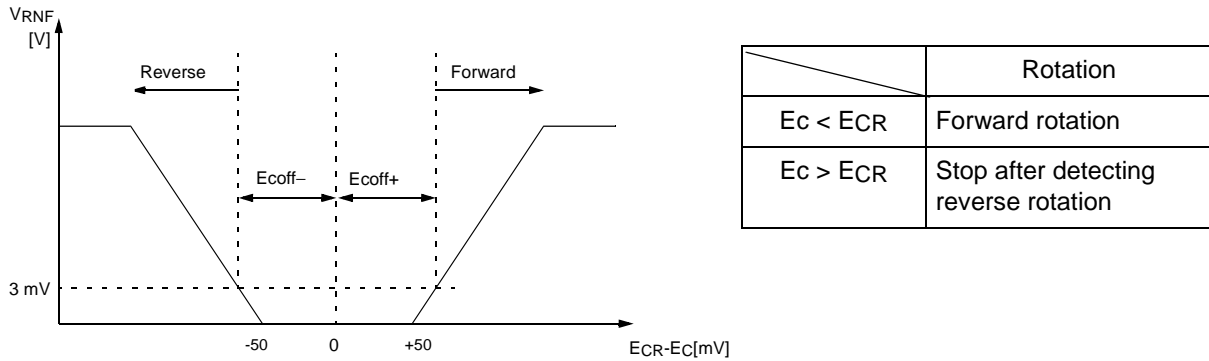

The input range (E_C) of the Torque Sense AMP is $0.5\text{V} \sim 3.3\text{V}$

5. Thermal Shutdown (TSD) Function

When the junction temperature rises up to about 165°C , then the output drive circuit is shut down, when the junction temperature falls off to about 140°C , the output drive circuit will be normally operated. It has the temperature hysteresis of about 25°C .

6. Rotational Direction Detecting Function

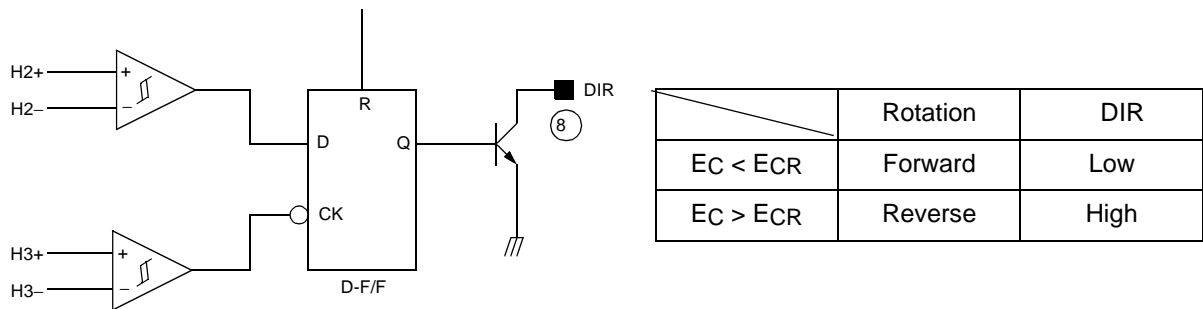

- The forward and reverse rotations of the MD are detected by the circuit, as shown in the above Table.
- The rotational direction of the MD can be learned by the output waveforms of the hall sensor and/or the driver. Let the three hall sensors be H1, H2 and H3 respectively. If the hall sensors turn on in the order, $H1 \rightarrow H2 \rightarrow H3$, of the reverse rotation, the output waveforms of the hall sensors will be as shown below.

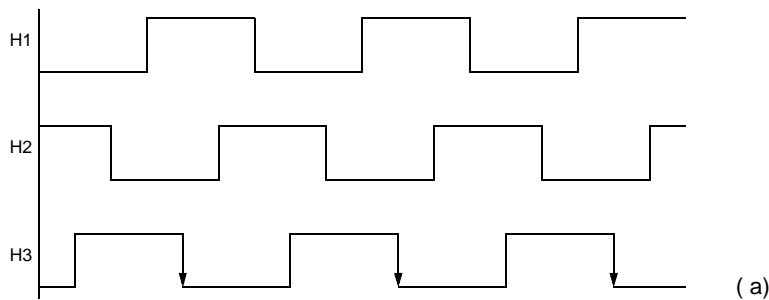

Inversely, if the hall sensors turn on in the order, H3→ H2→ H1, of the forward rotation, the output waveforms of the hall sensors will be as shown next page.

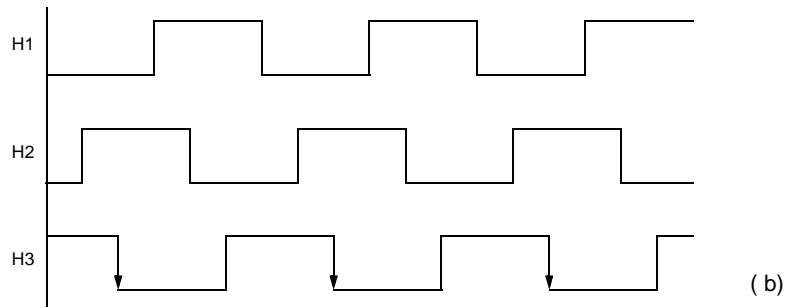

In the cases above, the value of H2 at the falling edges of H3 is Low in figure <a>, while High in figure . The rotational direction detector takes advantage of this phenomenon.

7. REVERSE ROTATION PREVENTING FUNCTION

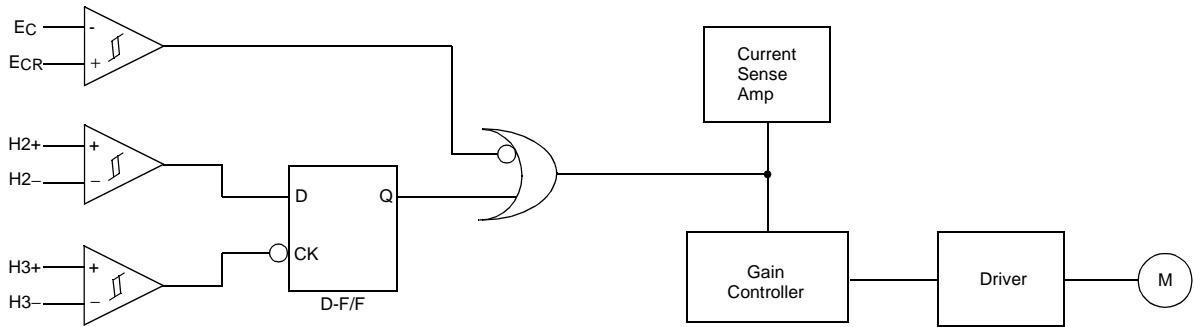

- The forward and reverse rotation of the motor are detected, as shown in the table below, by the circuit shown above. Consequently at reverse rotation, the D-F/F output Q becomes Low and cuts off the output current sense Amp, resulting in the stoppage of the Gain controller function.
- When the MD is rotating in forward direction, $EC > ECR$ is sometimes controlled to retard and/or stop the Motor. As the controlling time of $EC > ECR$ gets longer, Motor slows down, stops, and then rotates in the reverse direction. To prevent the Motor from rotating in the reverse direction, a reverse rotation resistant function is required. Its operational principles are discussed below.

Rotation	H2	H3	D-F/F	DIR	Reverse Rotation Preventer	
					$EC < ECR$	$EC > ECR$
Forward	H	H → L	H	L	Forward	Brake and Stop
Reverse	L	H → L	L	H	–	Stop

8. HALL INPUT OUTPUT TIMMING CHART

The 3-phase hall signal is amplified in the hall amplifiers and sent to the matrix section, where the signal is further amplified and combined. After the signal is converted to a current in the amplitude control circuit, the current is supplied to the output driver, which then provides a motor drive current. The phases of the hall input signal, output voltage, and output current are shown below.

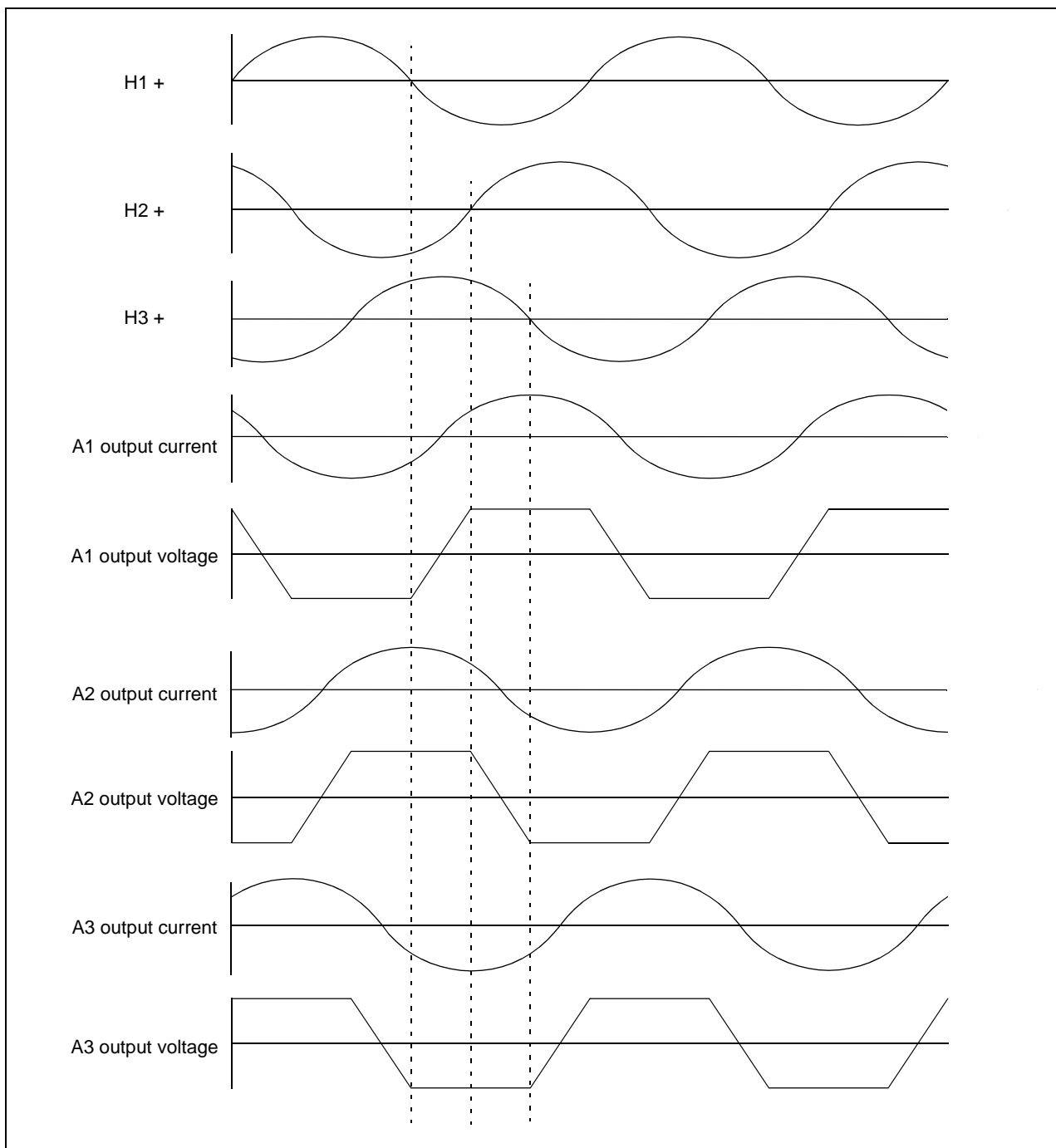

9. FG OUTPUT FUNCTION

The FG output, which detects the number of rotations of the MD, is generated by combination zero-crossing the output waveforms of the hall sensors. The FG output circuit is as shown below.

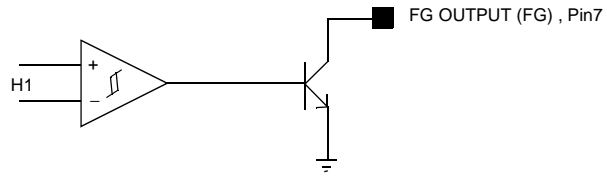

Typical Performance Characteristics

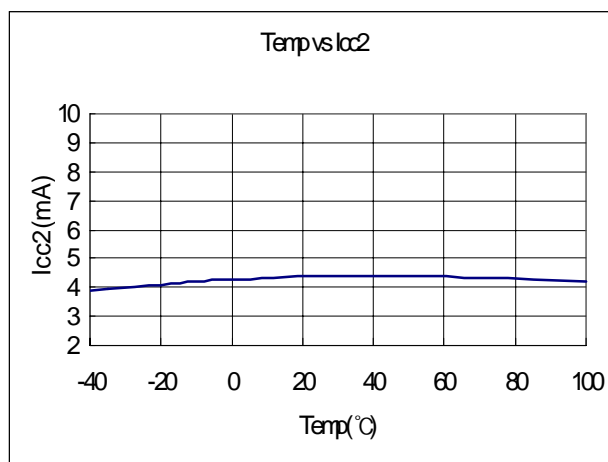
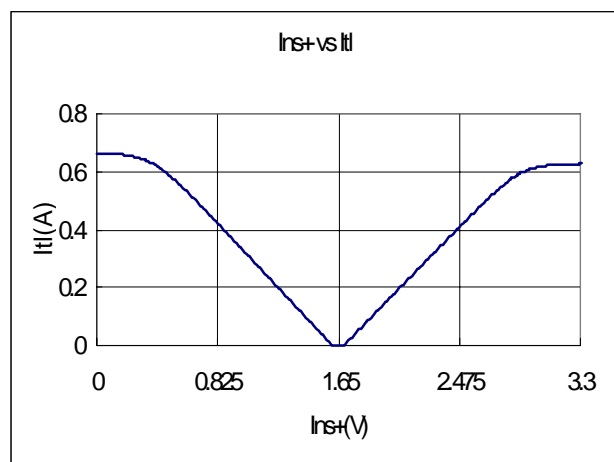
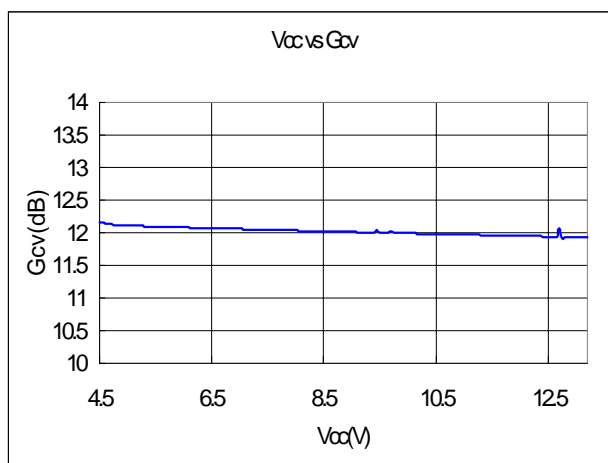
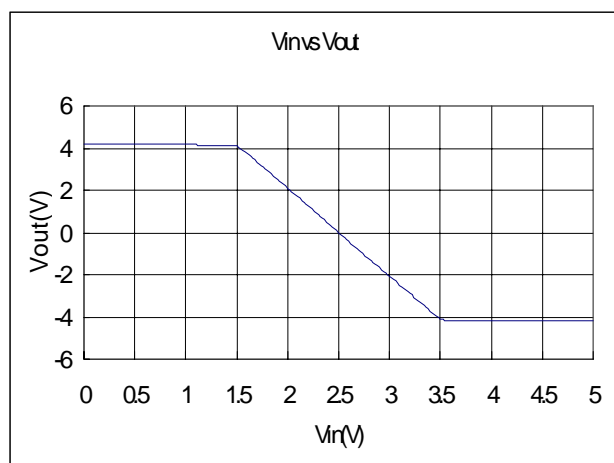
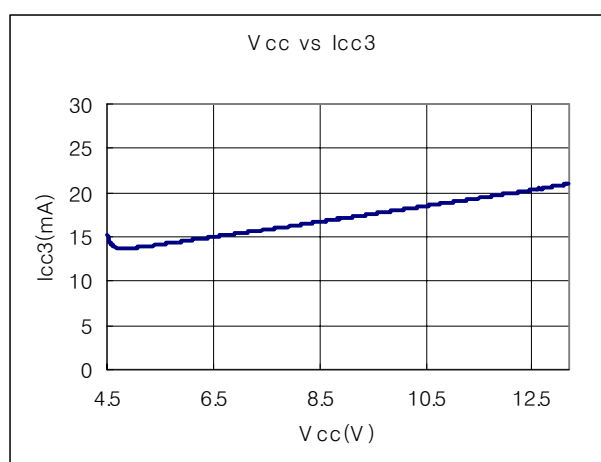
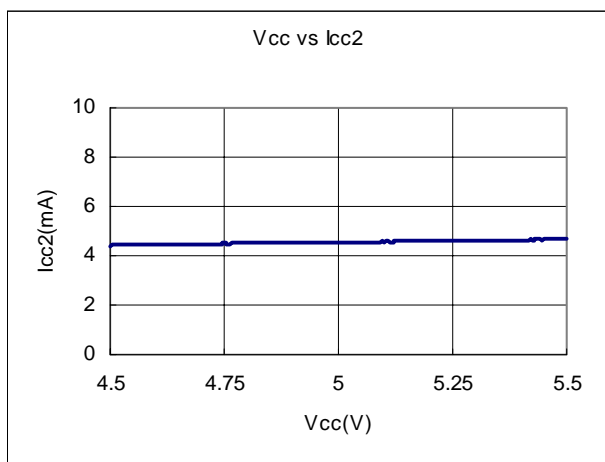

Typical Performance Characteristics

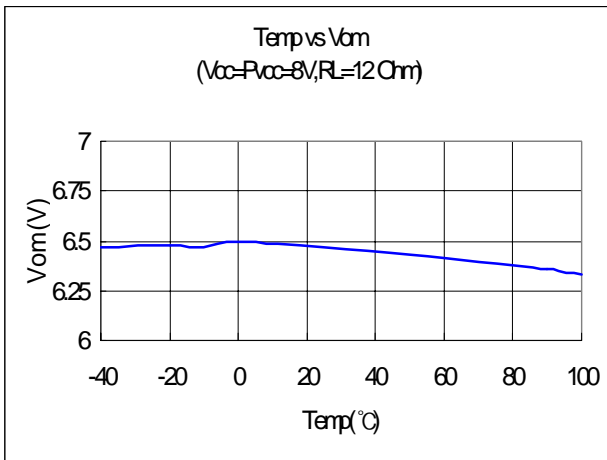
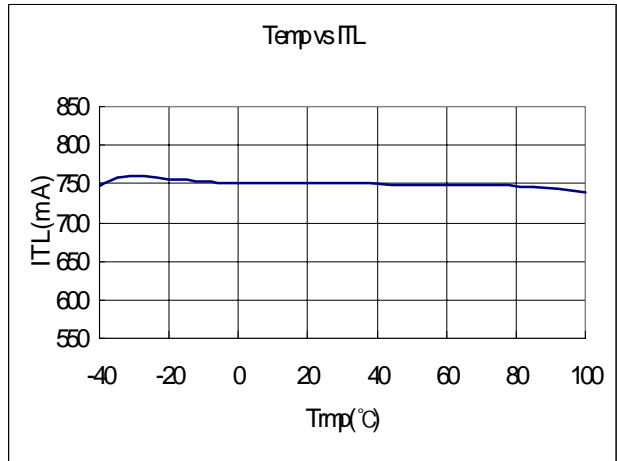
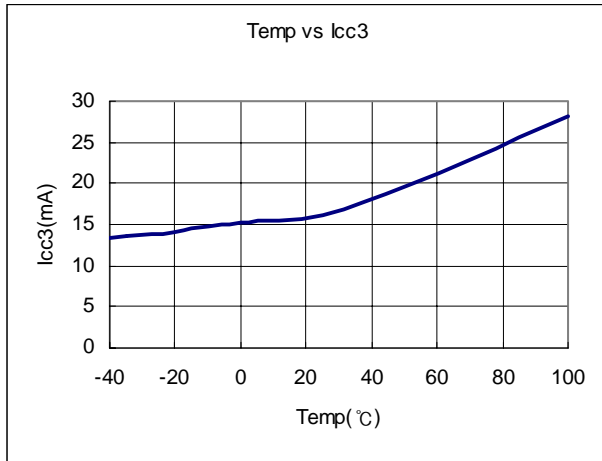

Test Circuits

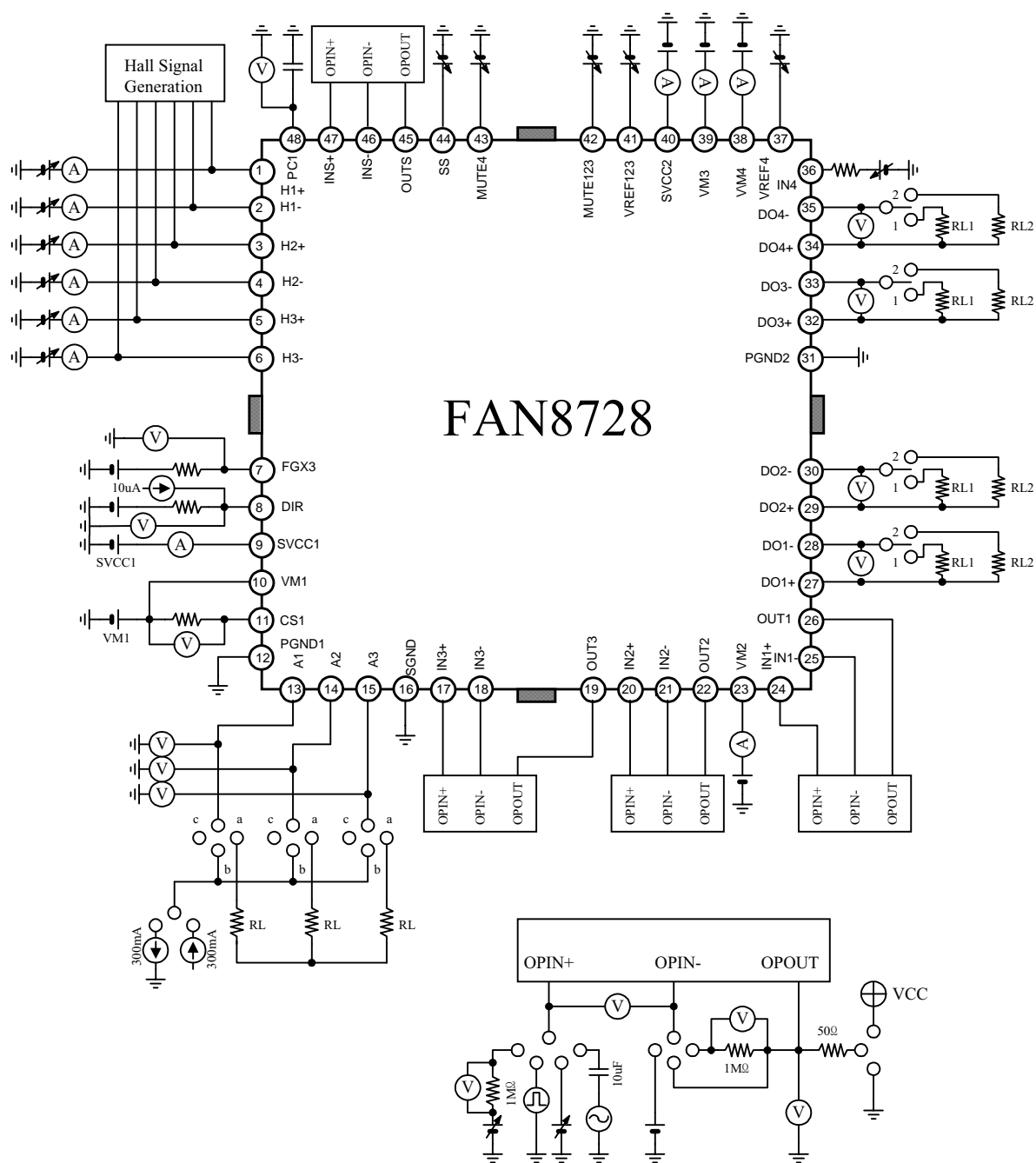

Application Circuits

Voltage Mode Control

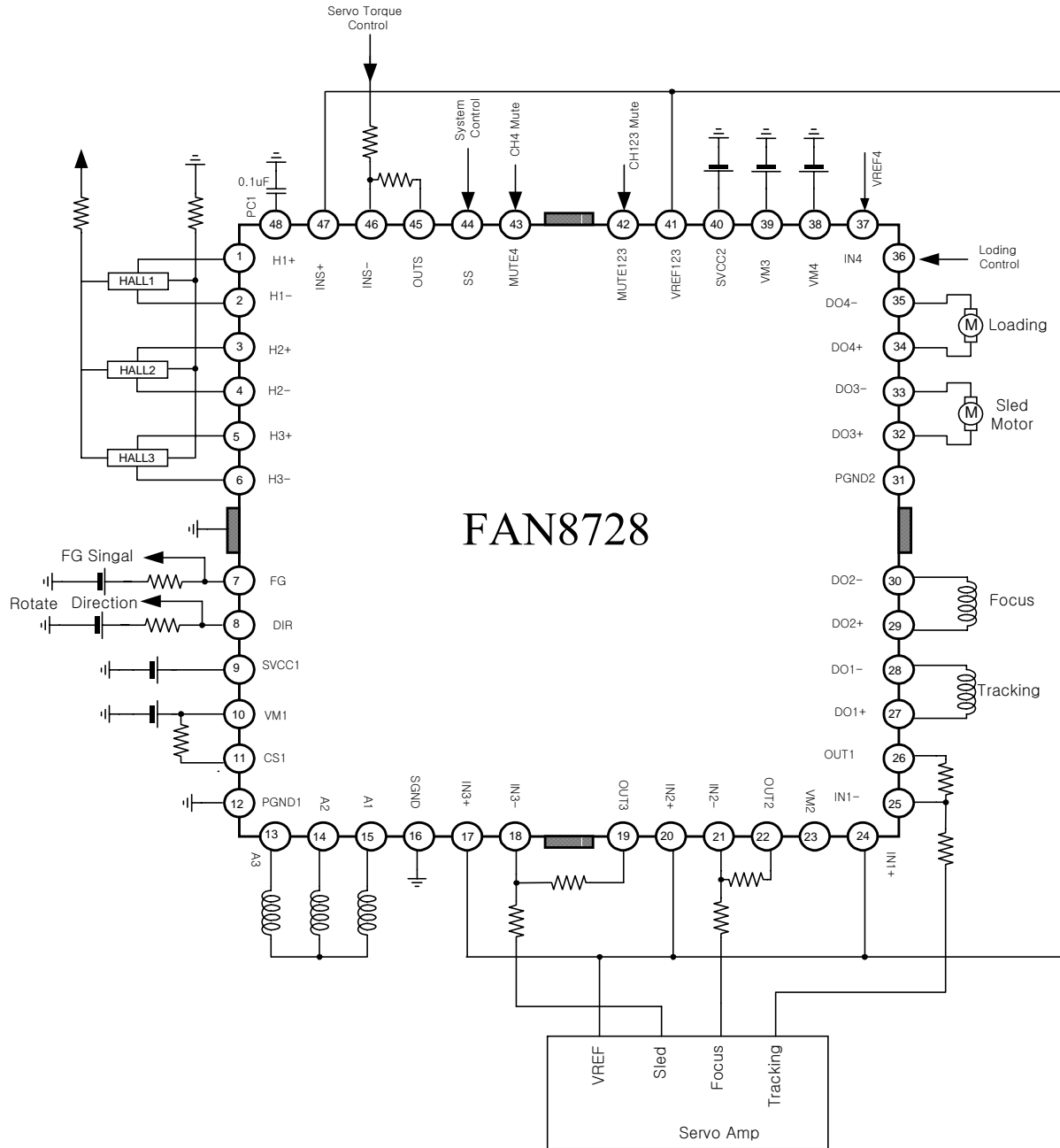

Application Circuits

Differential Mode Control

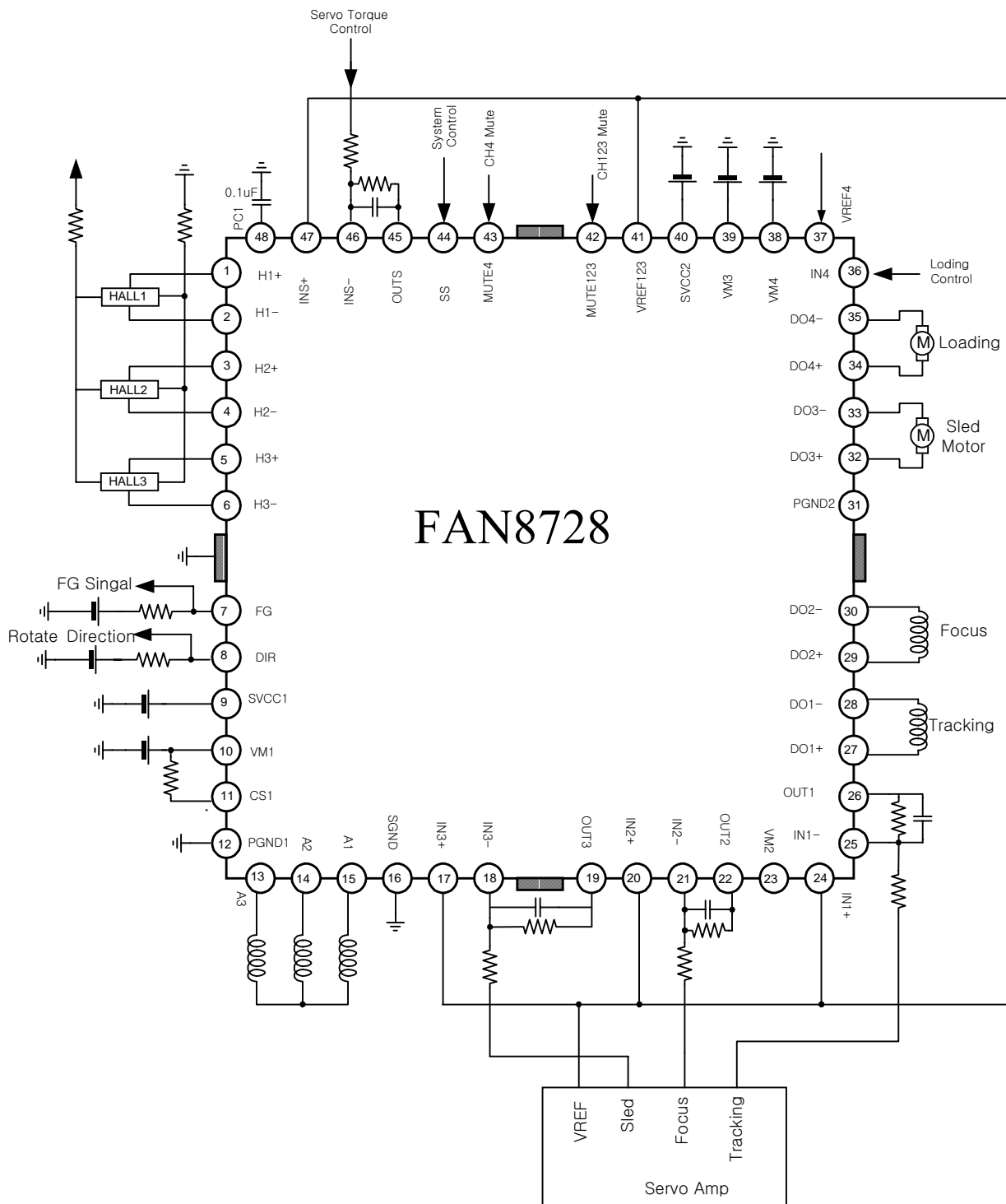

Package Dimensions (Unit: mm)

48-QFPH-1414

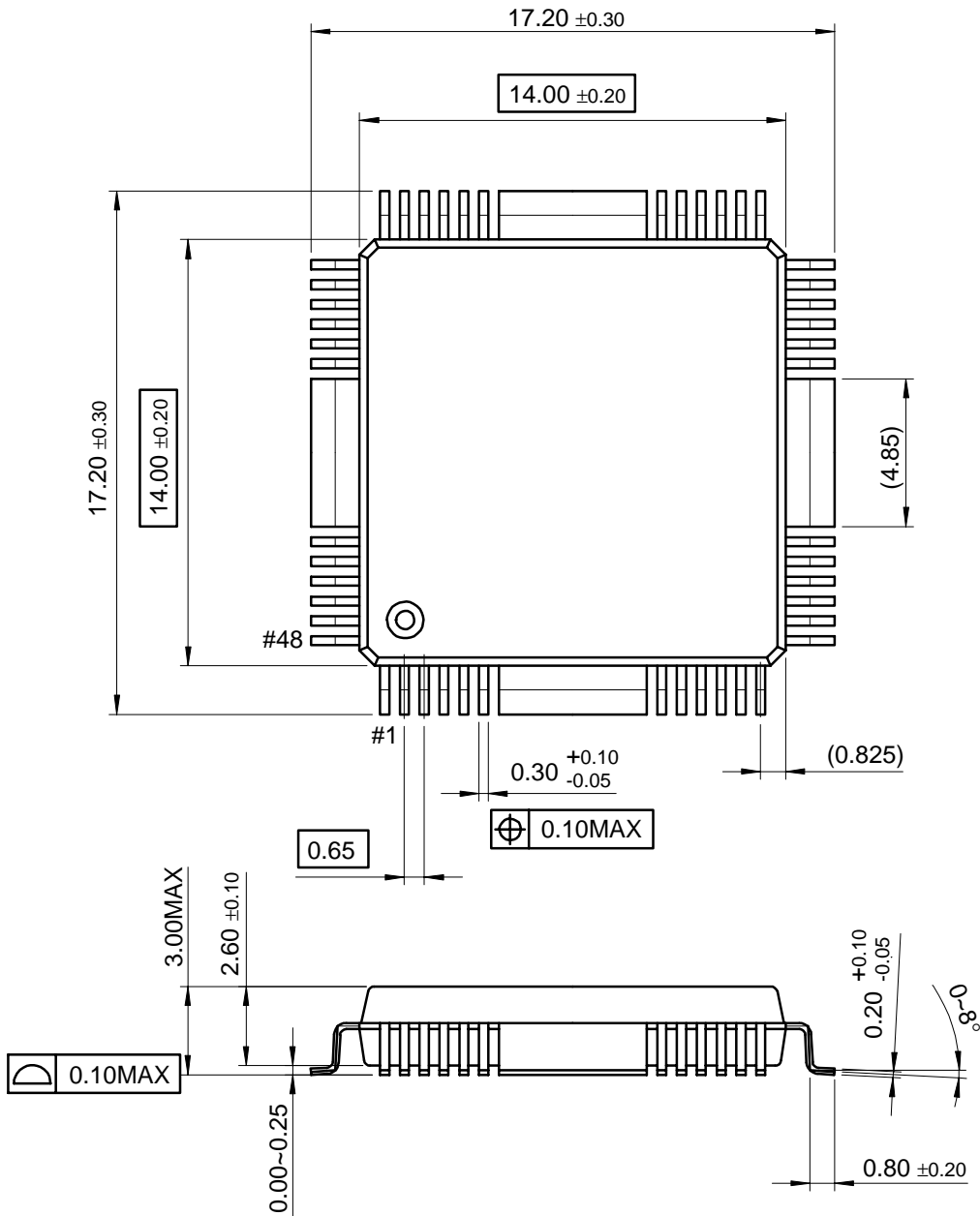

DISCLAIMER

FAIRCHILD SEMICONDUCTOR RESERVES THE RIGHT TO MAKE CHANGES WITHOUT FURTHER NOTICE TO ANY PRODUCTS HEREIN TO IMPROVE RELIABILITY, FUNCTION OR DESIGN. FAIRCHILD DOES NOT ASSUME ANY LIABILITY ARISING OUT OF THE APPLICATION OR USE OF ANY PRODUCT OR CIRCUIT DESCRIBED HEREIN; NEITHER DOES IT CONVEY ANY LICENSE UNDER ITS PATENT RIGHTS, NOR THE RIGHTS OF OTHERS.

LIFE SUPPORT POLICY

FAIRCHILD'S PRODUCTS ARE NOT AUTHORIZED FOR USE AS CRITICAL COMPONENTS IN LIFE SUPPORT DEVICES OR SYSTEMS WITHOUT THE EXPRESS WRITTEN APPROVAL OF THE PRESIDENT OF FAIRCHILD SEMICONDUCTOR CORPORATION. As used herein:

1. Life support devices or systems are devices or systems which, (a) are intended for surgical implant into the body, or (b) support or sustain life, and (c) whose failure to perform when properly used in accordance with instructions for use provided in the labeling, can be reasonably expected to result in a significant injury of the user.
2. A critical component in any component of a life support device or system whose failure to perform can be reasonably expected to cause the failure of the life support device or system, or to affect its safety or effectiveness.



LittleDiode supplies new, hard to find or obsolete electronic components and semiconductors all over the world.

With over two million different components listed you are sure to find the part you need.

Feel free to visit us today at our online store:

LittleDiode.com

Looking forward to providing you with the best possible service.