

3.3V/5V Output MD1421N

DESCRIPTION

The MD1421N is a high-efficiency step down DC-DC converter power integrated circuit with main MOSFET switch and synchronous rectification MOSFET. The MD1421N can deliver 15 watts maximum (5V, 3A) with high efficiency over a wide input voltage range. This device has output voltage digitally selectable for 3.3V or 5V. With the MD1421N you can construct a complete DC-DC converter using only a few external components. Featuring an SSOP 32-pin surface mount package, the MD1421N allows you to incorporate a very small and thin power supply on your circuit board.

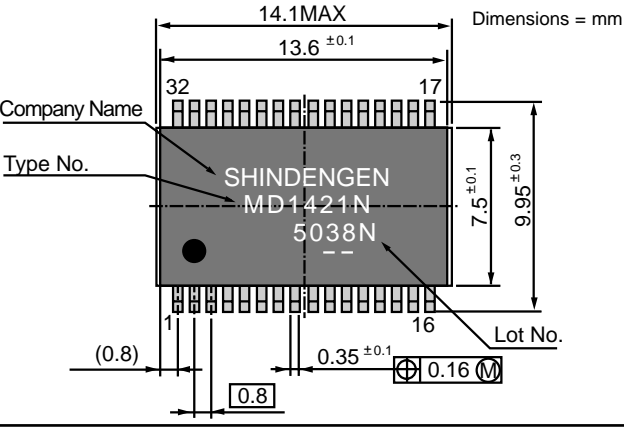

BLOCK DIAGRAM

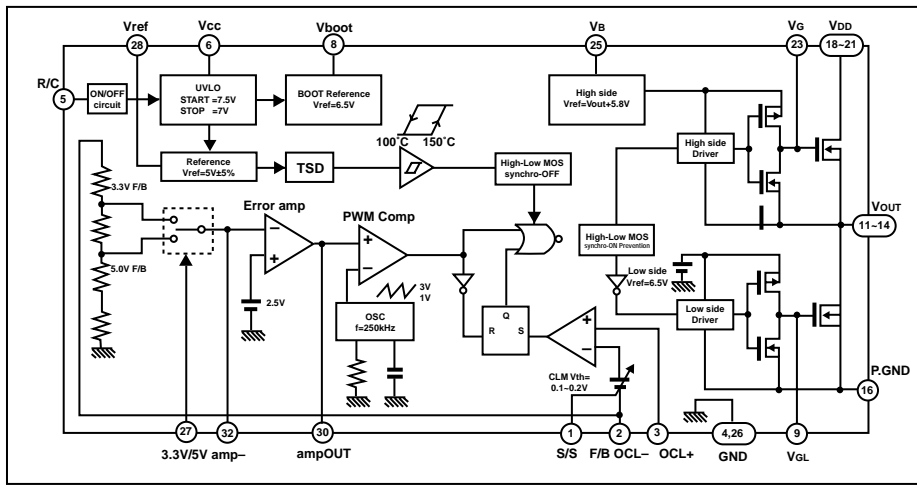

FEATURES

- High efficiency typ. 95%
- Wide input voltage load range 8VDC to 40VDC Up to 3ADC
- Output voltage selectable function 3.3V or 5V digitally
- Internal Switching power device Main MOSFET for switch and synchronous rectification MOSFET
- Fixed 250kHz PWM frequency (Without external resistor and capacitor)
- Overcurrent protection
- Thermal shutdown function
- Remote control ON/OFF

PIN ASSIGNMENT

Pin#	Symbol	Function description
1	S/S	Capacitor for softstart
2	F/B OCL-	Overcurrent protection (OCL) (-) and output voltage feedback
3	OCL+	Overcurrent protection (OCL) (+)
4	GND	Signal GND
5	R/C	Remote ON/OFF control terminal
6	Vcc	Input voltage
7	N/C	Non-connection
8	Vboot	High side drive supply for main MOS
9	VGL	Low side MOSFET gate terminal
10	N/C	Non-connection
11 - 14	Vout	Power stage output
15	N/C	Non-connection
16	P.GND	Power GND
17	N/C	Non-connection
18 - 21	VDD	Drain of main MOS Switch
22	N/C	Non-connection
23	VGH	Main switch high side MOSFET gate terminal
24	N/C	Non-connection
25	Vb	Bootstrap capacitor between VB and VOUT
26	GND	Signal GND
27	3.3V/5V Vref AmpOUT	Output voltage selectable terminal "L" means 5V output voltage "H" means 3.3V output voltage

28	Vref	Internal voltage reference
29	N/C	Non-connection
30	AmpOUT	Error Amp out
31	N/C	Non-connection
32	amp-	Error Amp (-) input

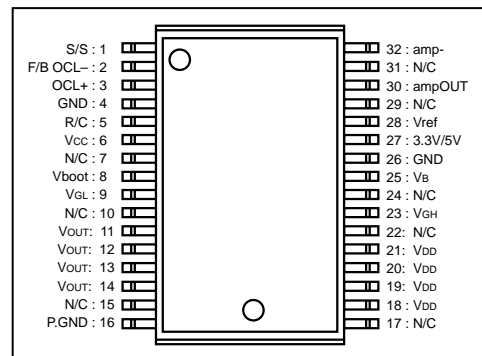

- **Vref** - Temperature compensated internal voltage. You can pull 1mA maximum for external circuit.
- **OSC** - MCD1421N uses internal oscillator without external component. Frequency (Saw tooth wave form) is trimmed to 250kHz on chip.
- **Error Amp** - Error Amp detects output voltage of DC-DC converter and controls PWM signal. You can adjust the loop gain when you connect feedback resistor and capacitor between AmpOUT and Amp (-). It will provide stable phase compensation.
- **Overcurrent protection** - MD1421N uses pulse-by-pulse current protection. Current will be sensed voltage drop of external current sensing resistor. Threshold of OCL is 0.19V.

ABSOLUTE MAXIMUM RATINGS

(Ta=25°C)

Parameter	Symbol	Rating	Units
Input voltage	V _{IN}	42	V
Main MOS voltage	V _{DD}	42	V
Output current (ave)	I _{OUTAVE}	3	A
Output Current (peak)	I _{OUTPEAK}	4	A
Remote Control Voltage	V _{RC}	5.5	°C
Storage temperature	T _{stg}	-40 ~ 150	°C
Junction temperature	T _j	150	°C

RECOMMENDED OPERATION CONDITIONS

Parameter	Recommendation	Units
Input voltage	8 ~ 40	V
Operation temperature	-10 ~ 80	°C

ELECTRIC CHARACTERISTICS

(Ta=25°C)

Parameter	Symbol	Conditions	MIN	TYP	MAX	Units
High side MOS D - S Breakdown Voltage	V _{dss}	I _D =1mA, V _{GS} =0V	42	-	-	V
High side MOS Drain Interruption Current	I _{dss}	V _{DS} =40V, V _{GS} =0V	-	-	10	µA
High side MOS Drain-source ON Resistance	R _{on}	I _D =1.2A, V _{GS} =4V	-	33	70	mΩ
High side MOS Source-drain DI forward voltage	V _{DS}	I _S =1.2A, V _{DS} =0V	-	-	1.5	V
Low side MOS D - S Breakdown Voltage	V _{dss}	I _D =1mA, V _{GS} =0V	42	-	-	V
Low side MOS Drain Interruption Current	I _{dss}	V _{DS} =40V, V _{GS} =0V	-	-	10	µA
Low side MOS Drain-source ON Resistance	R _{on}	I _D =1.2A, V _{GS} =4.5V	-	33	70	mΩ
Low side MOS Source-drain breakdown voltage	V _{SD}	I _S =1.2A, V _{DS} =0V	-	-	1.5	V
Start Voltage	V _{CC_start}	-	7	7.5	8	V
Stop Voltage	V _{CC_stop}	-	6.5	7	7.5	V
Stop-start voltage Hysteresis	V _{CC_hys}	-	-	0.5	-	V
Current consumption	I _{CC}	V _{CC} =8V ~ 40V	-	10	12	mA
Current consumption with remote control OFF	I _{CC_off}	V _{CC} =8V ~ 40V	-	1.2	1.5	mA
Voltage with remote control terminal ON	V _{RC_ON}	V _{CC} =8V ~ 40V	-0.2	-	0.5	V
Voltage with remote control terminal OFF	V _{RC_OFF}	V _{CC} =8V ~ 40V	2.5	-	5.3	V
Current with remote control terminals shorted	I _{RC}	V _{CC} =8V ~ 40V	-	-	250	µA
BOOT terminal voltage	V _{boot}	V _{CC} =24V	6	6.5	7	V
Internal Reference Voltage	V _{ref}	V _{CC} =8V ~ 40V	4.75	5	5.25	V
Internal Oscillation Frequency	f _{osc}	V _{CC} =24V	212.5	250	287.5	kHz
Overcurrent threshold voltage	V _{th_OCL}	V _{CC} =24V	0.162	0.19	0.218	V
Softstart terminal current	I _{S/S}	V _{CC} =24V	-20	-12.5	-5	µA
"H" CHG terminal input voltage	V _{CHGH}	-	4.5	-	V _{ref}	V
"L" CHG terminal input voltage	V _{CHGL}	-	GND	-	0.5	V
Overcurrent protection operating temperature	T _{TSD}	-	-	150	-	°C