

Emitter common (dual digital transistors)

EMA11 / UMA11N / FMA11A

●Features

- 1) Two DTA143Z chips in a EMT or UMT or SMT package.
- 2) Mounting cost and area can be cut in half.

●Structure

Epitaxial planar type
PNP silicon transistor
(Built-in resistor type)

The following characteristics apply to both DTr₁ and DTr₂.

●Equivalent circuit

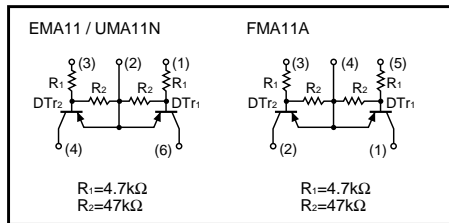

●External dimensions (Units : mm)

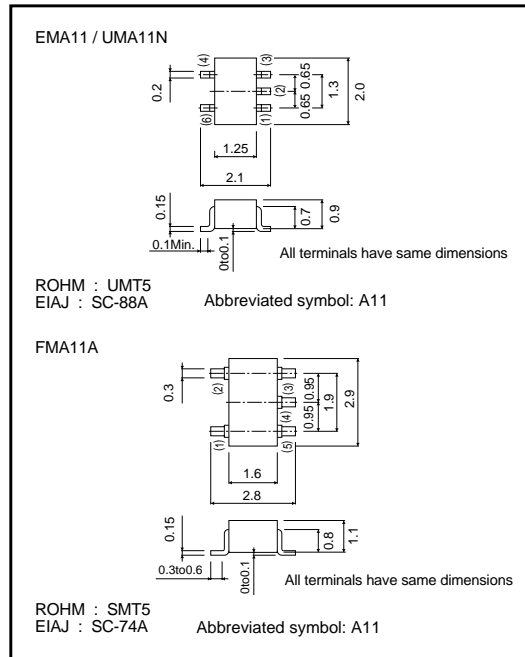

●Packaging specifications

Type	Package	Taping		
	Code	T2R	TR	T148
	Basic ordering unit (pieces)	8000	3000	3000
EMA11		○	-	-
UMA11N		-	○	-
FMA11A		-	-	○

●Absolute maximum ratings (Ta = 25°C)

Parameter	Symbol	Limits	Unit
Supply voltage	V _{CC}	-50	V
Input voltage	V _{IN}	-30	V
		5	
Output current	I _O	-100	mA
	I _{C (Max.)}	-100	
Power dissipation	EMA11 / UMA11N	150 (TOTAL)	*1
	FMA11A	300 (TOTAL)	*2
Junction temperature	T _J	150	°C
Storage temperature	T _{stg}	-55~+150	°C

*1 120mW per element must not be exceeded.
*2 200mW per element must not be exceeded.

Transistors

●Electrical characteristics (Ta = 25°C)

Parameter	Symbol	Min.	Typ.	Max.	Unit	Conditions
Input voltage	$V_{I(off)}$	-	-	-0.5	V	$V_{CC}=-5V, I_o=-100\mu A$
	$V_{I(on)}$	-1.3	-	-		$V_o=-0.3V, I_o=-5mA$
Output voltage	$V_{O(on)}$	-	-0.1	-0.3	V	$I_o/I_i=-5mA/-0.25mA$
Input current	I_i	-	-	-1.8	mA	$V_i=-5V$
Output current	$I_o(off)$	-	-	-0.5	μA	$V_{CC}=-50V, V_i=0V$
DC current gain	G_i	80	-	-	-	$V_o=-5V, I_o=-10mA$
Transition frequency	f_T	-	250	-	MHz	$V_{CE}=10mA, I_E=-5mA, f=100MHz$ *
Input resistance	R_i	3.29	4.7	6.11	$k\Omega$	-
Resistance ratio	R_2/R_1	8	10	12	-	-

* Transition frequency of the device

●Electrical characteristic curves

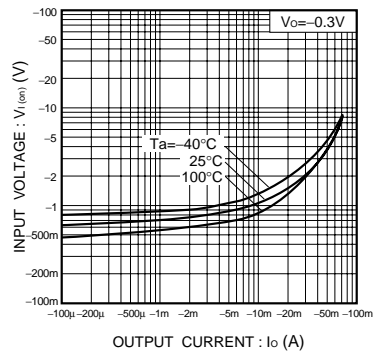

Fig.1 Input voltage vs. output current (ON characteristics)

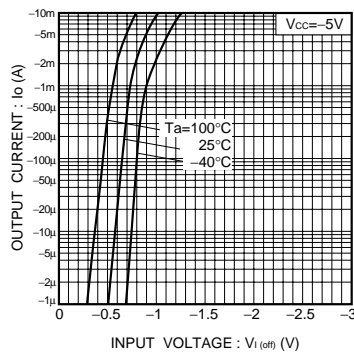

Fig.2 Output current vs. input voltage (OFF characteristics)

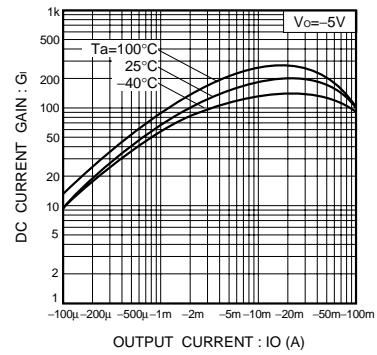

Fig.3 DC current gain vs. output current

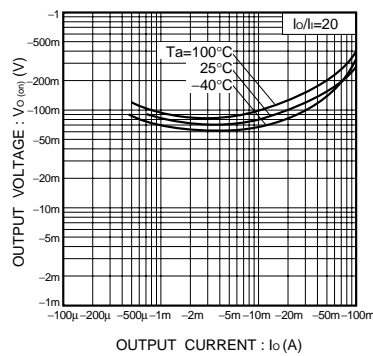

Fig.4 Output voltage vs. output current



LittleDiode supplies new, hard to find or obsolete electronic components and semiconductors all over the world.

With over two million different components listed you are sure to find the part you need.

Feel free to visit us today at our online store:

LittleDiode.com

Looking forward to providing you with the best possible service.