

FPBL30SL60

Smart Power Module (SPM)

General Description

FPBL30SL60 is an advanced smart power module (SPM) that Fairchild has newly developed and designed to provide very compact and low cost, yet high performance ac motor drives mainly targeting low speed low-power inverter-driven application like air conditioners. It combines optimized circuit protection and drive matched to low-loss IGBTs. Highly effective short-circuit current detection/protection is realized through the use of advanced current sensing IGBT chips that allow continuous monitoring of the IGBTs current. System reliability is further enhanced by the integrated under-voltage lock-out protection. The high speed built-in HVIC provides opto-coupler-less IGBT gate driving capability that further reduce the overall size of the inverter system design. In addition the incorporated HVIC facilitates the use of single-supply drive topology enabling the FPBL30SL60 to be driven by only one drive supply voltage without negative bias.

Features

- UL Certified No. E209204
- 600V-30A 3-phase IGBT inverter bridge including control ICs for gate driving and protection
- Single-grounded power supply due to built-in HVIC
- Typical switching frequency of 3kHz
- Inverter power rating of 2kW / 100~253 Vac
- Isolation rating of 2500Vrms/min.
- Very low leakage current due to using ceramic substrate
- Adjustable current protection level by varying series resistor value with sense-IGBTs

Applications

- AC 100V ~ 253V three-phase inverter drive for small power (2kW) ac motor drives
- Home appliances applications requiring low switching frequency operation like air conditioners drive system
- Application ratings:
 - Power : 2kW / 100~253 Vac
 - Switching frequency : Typical 3kHz (PWM Control)
 - 100% load current : 15A (Irms)

External View and Marking Information

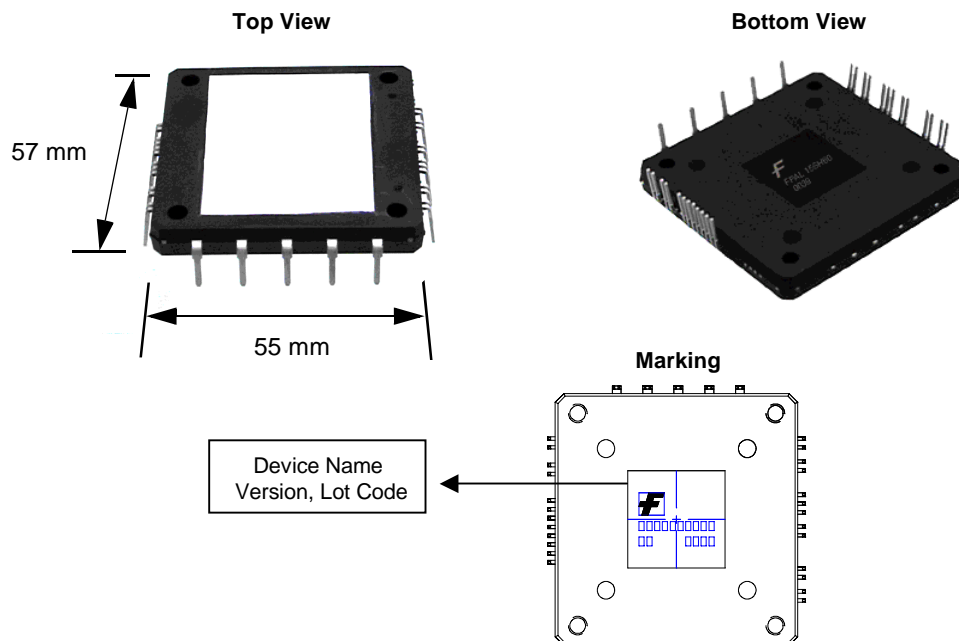

Fig. 1.

Integrated Power Functions

- 600V-30A IGBT inverter for three-phase DC/AC power conversion (Please refer to Fig. 3)

Integrated Drive, Protection and System Control Functions

- For inverter high-side IGBTs: Gate drive circuit, High voltage isolated high-speed level shifting
Control circuit under-voltage (UV) protection
Note) Available bootstrap circuit example is given in Figs. 10, 15 and 16.
- For inverter low-side IGBTs: Gate drive circuit, Short circuit protection (SC)
Control supply circuit under-voltage (UV) protection
- Fault signaling: Corresponding to a SC fault (Low-side IGBTs) or a UV fault (Low-side supply)
- Input interface: 5V CMOS/LSTTL compatible, Schmitt trigger input

Pin Configuration

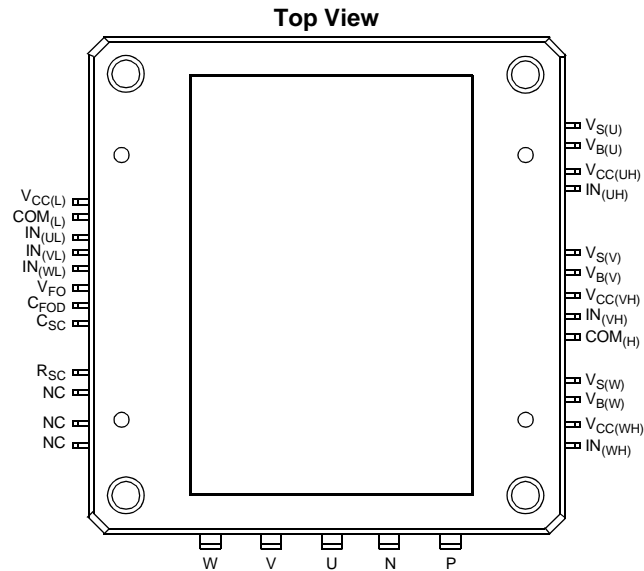

Fig. 2.

Pin Descriptions

Pin Number	Pin Name	Pin Description
1	$V_{CC(L)}$	Low-side Common Bias Voltage for IC and IGBTs Driving
2	$COM(L)$	Low-side Common Supply Ground
3	$IN_{(UL)}$	Signal Input Terminal for Low-side U Phase
4	$IN_{(VL)}$	Signal Input Terminal for Low-side V Phase
5	$IN_{(WL)}$	Signal Input Terminal for Low-side W Phase
6	V_{FO}	Fault Output Terminal
7	C_{FOD}	Capacitor for Fault Output Duration Time Selection
8	C_{SC}	Capacitor (Low-pass Filter) for Short-current Detection Input
9	R_{SC}	Resistor for Short-circuit Current Detection
10	NC	No Connection
11	NC	No Connection
12	NC	No Connection
13	W	Output Terminal for W Phase
14	V	Output Terminal for V Phase
15	U	Output Terminal for U Phase
16	N	Negative DC-Link Input

Pin Descriptions (Continued)

Pin Number	Pin Name	Pin Description
17	P	Positive DC-Link Input
18	IN _(WH)	Signal Input Terminal for High-side W Phase
19	V _{CC(WH)}	High-side Bias Voltage for W Phase IC
20	V _{B(W)}	High-side Bias Voltage for W Phase IGBT Driving
21	V _{S(W)}	High-side Bias Voltage Ground for W Phase IGBT Driving
22	COM _(H)	High-side Common Supply Ground
23	IN _(VH)	Signal Input Terminal for High-side V Phase
24	V _{CC(VH)}	High-side Bias Voltage for V Phase IC
25	V _{B(V)}	High-side Bias Voltage for V Phase IGBT Driving
26	V _{S(V)}	High-side Bias Voltage Ground for V Phase IGBT Driving
27	IN _(UH)	Signal Input Terminal for High-side U Phase
28	V _{CC(UH)}	High-side Bias Voltage for U Phase IC
29	V _{B(U)}	High-side Bias Voltage for U Phase IGBT Driving
30	V _{S(U)}	High-side Bias Voltage Ground for U Phase IGBT Driving

Internal Equivalent Circuit and Input/Output Pins

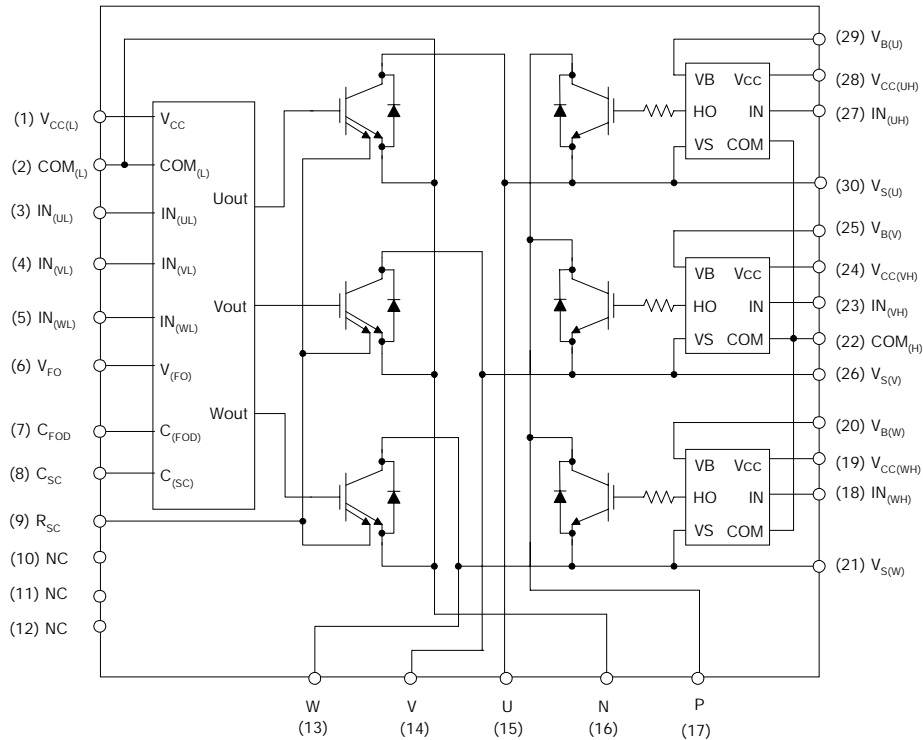

Note

1. Inverter low-side ((1) - (12) pins) is composed of three sense-IGBTs including freewheeling diodes for each IGBT and one control IC which has gate driving, current sensing and protection functions.
2. Inverter power side ((13) - (17) pins) is composed of two inverter dc-link input terminals and three inverter output terminals.
3. Inverter high-side ((18) - (30) pins) is composed of three normal-IGBTs including freewheeling diodes and three drive ICs for each IGBT.

Fig. 3.

Absolute Maximum Ratings

Inverter Part ($T_C = 25^\circ\text{C}$, Unless Otherwise Specified)

Item	Symbol	Condition	Rating	Unit
Supply Voltage	V_{DC}	Applied to DC - Link	450	V
Supply Voltage (Surge)	$V_{PN(Surge)}$	Applied between P- N	500	V
Collector-Emitter Voltage	V_{CES}		600	V
Each IGBT Collector Current	$\pm I_C$	$T_C = 25^\circ\text{C}$ (Note Fig. 4)	30	A
Each IGBT Collector Current (Peak)	$\pm I_{CP}$	$T_C = 25^\circ\text{C}$ (Note Fig. 4)	60	A
Collector Dissipation	P_C	$T_C = 25^\circ\text{C}$ per One Chip	56	W
Operating Junction Temperature	T_J	(Note 1)	-55 ~ 150	$^\circ\text{C}$

Note

1. It would be recommended that the average junction temperature should be limited to $T_J \leq 125^\circ\text{C}$ (@ $T_C \leq 100^\circ\text{C}$) in order to guarantee safe operation.

Control Part ($T_C = 25^\circ\text{C}$, Unless Otherwise Specified)

Item	Symbol	Condition	Rating	Unit
Control Supply Voltage	V_{CC}	Applied between $V_{CC(H)}$ - $COM_{(H)}$, $V_{CC(L)}$ - $COM_{(L)}$	18	V
High-side Control Bias Voltage	V_{BS}	Applied between $V_{B(U)}$ - $V_{S(U)}$, $V_{B(V)}$ - $V_{S(V)}$, $V_{B(W)}$ - $V_{S(W)}$	20	V
Input Signal Voltage	V_{IN}	Applied between $IN_{(UH)}$, $IN_{(VH)}$, $IN_{(WH)}$ - $COM_{(H)}$ $IN_{(UL)}$, $IN_{(VL)}$, $IN_{(WL)}$ - $COM_{(L)}$	-0.3 ~ 6.0	V
Fault Output Supply Voltage	V_{FO}	Applied between V_{FO} - $COM_{(L)}$	-0.3~ $V_{CC}+0.5$	V
Fault Output Current	I_{FO}	Sink Current at V_{FO} Pin	5	mA
Current Sensing Input Voltage	V_{SC}	Applied between C_{SC} - $COM_{(L)}$	-0.3~ $V_{CC}+0.5$	V

Total System

Item	Symbol	Condition	Rating	Unit
Self Protection Supply Voltage Limit (Short Circuit Protection Capability)	$V_{DC(PROT)}$	Applied to DC - Link, $V_{CC} = V_{BS} = 13.5 \sim 16.5\text{V}$ $T_J = 125^\circ\text{C}$, Non-repetitive, less than $6\mu\text{s}$	400	V
Module Case Operation Temperature	T_C	Note Fig. 4	-20 ~ 100	$^\circ\text{C}$
Storage Temperature	T_{STG}		-55 ~ 150	$^\circ\text{C}$
Isolation Voltage	V_{ISO}	60Hz, Sinusoidal, AC 1 minute, Connection Pins to Heat-sink Plate	2500	V_{rms}

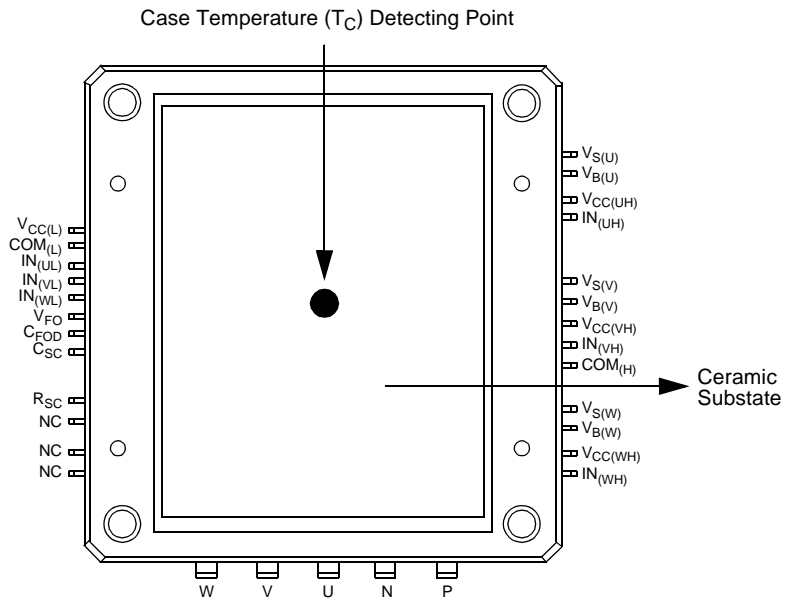

Fig. 4. T_C Measurement Point

Absolute Maximum Ratings

Thermal Resistance

Item	Symbol	Condition	Min.	Typ.	Max.	Unit
Junction to Case Thermal Resistance	$R_{th(j-c)Q}$	Each IGBT under Inverter Operating Condition (Note 2)	-	-	2.2	°C/W
	$R_{th(j-c)F}$	Each FWDi under Inverter Operating Condition (Note 2)	-	-	3.18	°C/W
Contact Thermal Resistance	$R_{th(c-f)}$	Ceramic Substrate (per 1 Module) Thermal Grease Applied	-	-	0.06	°C/W

Note

2. For the measurement point of case temperature (T_c), please refer to Fig. 4.

Electrical Characteristics

Inverter Part ($T_j = 25^\circ\text{C}$, Unless Otherwise Specified)

Item	Symbol	Condition	Min.	Typ.	Max.	Unit	
Collector - Emitter Saturation Voltage	$V_{CE(SAT)}$	$V_{CC} = V_{BS} = 15\text{V}$ $V_{IN} = 0\text{V}$	$I_C = 30\text{A}, T_j = 25^\circ\text{C}$	-	-	2.3	V
			$I_C = 30\text{A}, T_j = 125^\circ\text{C}$	-	-	2.4	V
FWDi Forward Voltage	V_{FM}	$V_{IN} = 5\text{V}$	$I_C = 30\text{A}, T_j = 25^\circ\text{C}$	-	-	2.5	V
			$I_C = 30\text{A}, T_j = 125^\circ\text{C}$	-	-	2.3	V
Switching Times	t_{ON}	$V_{PN} = 300\text{V}, V_{CC} = V_{BS} = 15\text{V}$ $I_C = 30\text{A}, T_j = 25^\circ\text{C}$ $V_{IN} = 5\text{V} \leftrightarrow 0\text{V}$, Inductive Load (High-Low Side)	-	0.45	-	μs	
	$t_{C(ON)}$		-	0.18	-	μs	
	t_{OFF}		-	0.9	-	μs	
	$t_{C(OFF)}$		-	0.36	-	μs	
	t_{rr}		(Note 3)	-	0.1	-	μs
Collector - Emitter Leakage Current	I_{CES}	$V_{CE} = V_{CES}, T_j = 25^\circ\text{C}$	-	-	250	μA	

Note

3. t_{ON} and t_{OFF} include the propagation delay time of the internal drive IC. $t_{C(ON)}$ and $t_{C(OFF)}$ are the switching time of IGBT itself under the given gate driving condition internally. For the detailed information, please see Fig. 5.

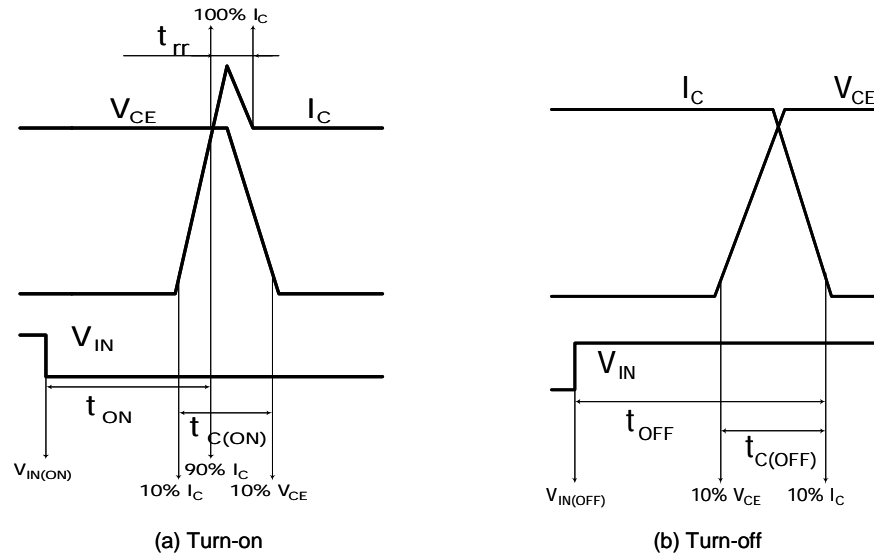

Fig 5. Switching Time Definition

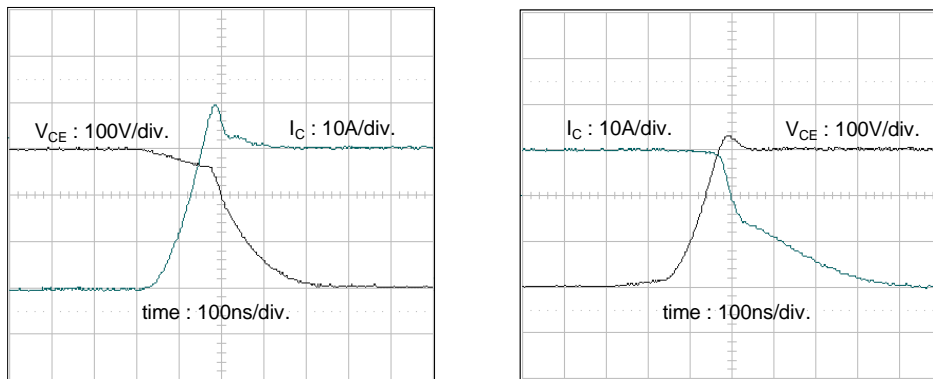

Fig. 6. Experimental Results of Switching Waveforms
 Test Condition: $V_{dc}=300V$, $V_{cc}=15V$, $L=500\mu H$ (Inductive Load), $T_C=25^\circ C$

Electrical Characteristics

Control Part ($T_J = 25^\circ\text{C}$, Unless Otherwise Specified)

Item	Symbol	Condition	Min.	Typ.	Max.	Unit		
Control Supply Voltage	V_{CC}	Applied between $V_{CC(H)}, V_{CC(L)}$ - COM	13.5	15	16.5	V		
High-Side Bias Voltage	V_{BS}	Applied between $V_{B(U)} - V_{S(U)}, V_{B(V)} - V_{S(V)}, V_{B(W)} - V_{S(W)}$	13.5	15	16.5	V		
Quiescent V_{CC} Supply Current	I_{QCCL}	$V_{CC} = 15\text{V}$ $I_{N(UL, VL, WL)} = 5\text{V}$			26	mA		
	I_{QCCH}	$V_{CC} = 15\text{V}$ $I_{N(UH, VH, WH)} = 5\text{V}$			130	uA		
Quiescent V_{BS} Supply Current	I_{QBS}	$V_{BS} = 15\text{V}$ $I_{N(UH, VH, WH)} = 5\text{V}$			420	uA		
Fault Output Voltage	V_{FOH}	$V_{SC} = 0\text{V}$, V_{FO} Circuit: 4.7k Ω to 5V Pull-up	4.5	-	-	V		
	V_{FOL}	$V_{SC} = 1\text{V}$, V_{FO} Circuit: 4.7k Ω to 5V Pull-up	-	-	1.1	V		
PWM Input Frequency	f_{PWM}	$T_C \leq 100^\circ\text{C}$, $T_J \leq 125^\circ\text{C}$	-	3	-	kHz		
Allowable Input Signal Blanking Time Considering Leg Arm-Short	t_{dead}	$-20^\circ\text{C} \leq T_C \leq 100^\circ\text{C}$	3	-	-	us		
Short Circuit Trip Level	$V_{SC(ref)}$	$T_J = 25^\circ$, $V_{CC} = 15\text{V}$ (Note 4)	0.45	0.51	0.56	V		
Sensing Voltage of IGBT Current	V_{SEN}	$-20^\circ\text{C} \leq T_C \leq 100^\circ\text{C}$, @ $R_{SC} = 82\ \Omega$ and $I_C = 30\text{A}$ (Note Fig. 7)	0.37	0.45	0.56	V		
Supply Circuit Under-Voltage Protection	UV_{CCD}	$T_J \leq 125^\circ\text{C}$	Detection Level	11.5	12	12.5	V	
	UV_{CCR}		Reset Level	12	12.5	13	V	
	UV_{BSD}		Detection Level	7.3	9.0	10.8	V	
	UV_{BSR}		Reset Level	8.6	10.3	12	V	
Fault-Out Pulse Width	t_{FOD}	$V_{CC} = 15\text{V}$, $C(sc) = 1\text{V}$ $C_{FOD} = 33\text{nF}$ (Note 5)	1.4	1.8	2.0	ms		
ON Threshold Voltage	$V_{IN(ON)}$	High-Side	Applied between $I_{N(UH)}, I_{N(VH)}, I_{N(WH)}$ - $COM(H)$		-	-	0.8	V
OFF Threshold Voltage	$V_{IN(OFF)}$		3.0	-	-	V		
ON Threshold Voltage	$V_{IN(ON)}$	Low-Side	Applied between $I_{N(UL)}, I_{N(VL)}, I_{N(WL)}$ - $COM(L)$		-	-	0.8	V
OFF Threshold Voltage	$V_{IN(OFF)}$		3.0	-	-	V		

Note

- Short-circuit current protection is functioning only at the low-sides. It would be recommended that the value of the external sensing resistor (R_{SC}) should be selected around 56 Ω in order to make the SC trip-level of about 45A.
Please refer to Fig. 7 which shows the current sensing characteristics according to sensing resistor R_{SC} .
- The fault-out pulse width t_{FOD} depends on the capacitance value of C_{FOD} according to the following approximate equation : $C_{FOD} = 18.3 \times 10^{-6} \times t_{FOD}[F]$

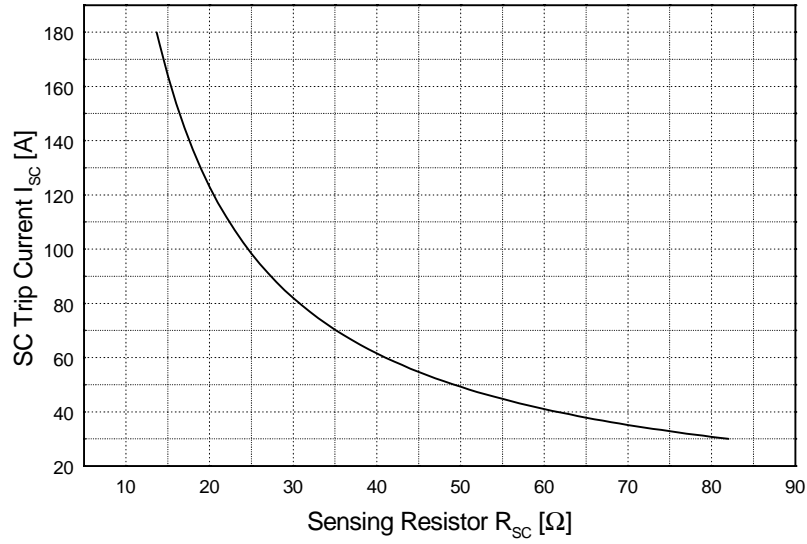

Fig. 7. Relationship between Sensing Resistor and SC Trip Current for Short-Circuit Protection
 $(I_{sc} = 82 \times \text{Rating Current}(30A) / R_{sc})$

Mechanical Characteristics and Ratings

Item	Condition		Limits			Units
			Min.	Typ.	Max.	
Mounting Torque	Mounting Screw: M3 (Note 6 and 7)	Recommended 10kg•cm	8	10	12	Kg•cm
		Recommended 0.98N•m	0.78	0.98	1.17	N•m
Ceramic Flatness		(Note Fig. 8)	0	-	+100	um
Weight			-	56	-	g

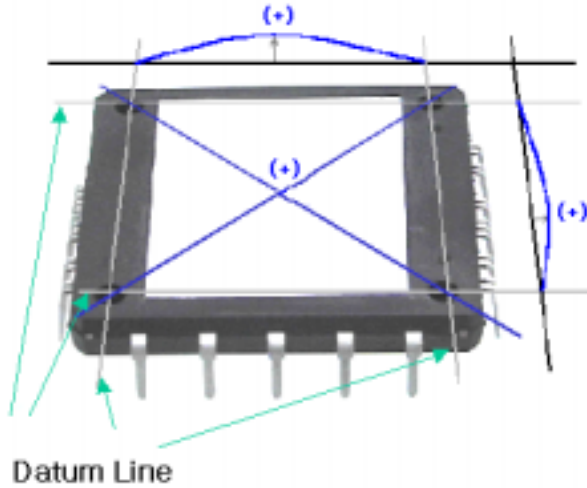

Fig. 8. Flatness Measurement Position of The Ceramic Substrate

Note

- 6. Do not make over torque or mounting screws. Much mounting torque may cause ceramic cracks and bolts and AI heat-fin destruction.
- 7. Avoid one side tightening stress. Fig.9 shows the recommended torque order for mounting screws. Uneven mounting can cause the SPM ceramic substrate to be damaged.

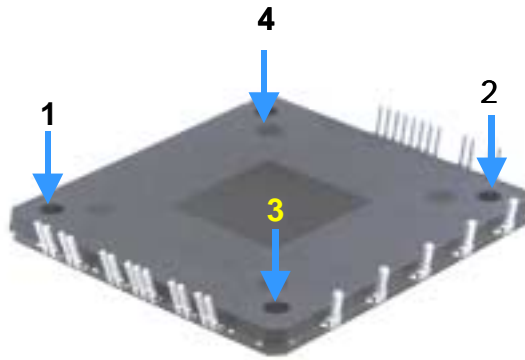
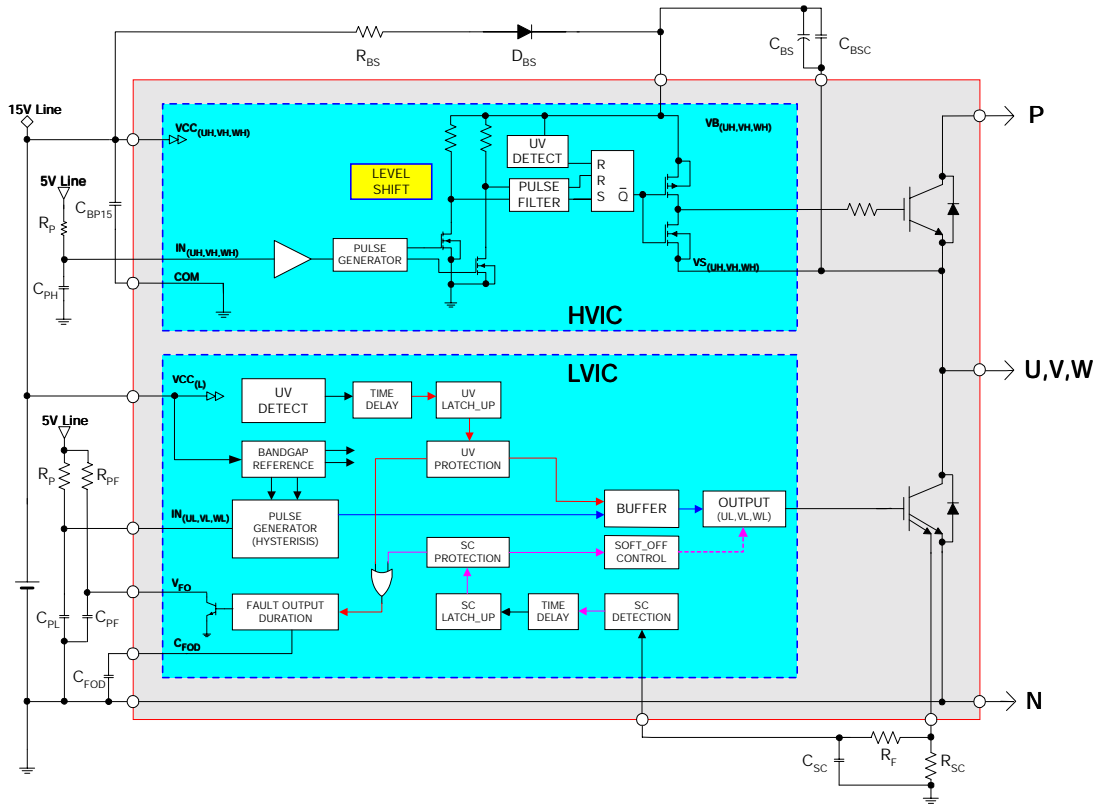

Fig. 9. Mounting Screws Torque Order (1 → 2 → 3 → 4)

Recommended Operating Conditions

Item	Symbol	Condition	Value			Unit
			Min.	Typ.	Max.	
Supply Voltage	V_{PN}	Applied between P - N	-	300	400	V
Control Supply Voltage	V_{CC}	Applied between $V_{CC(H)}$ - $COM_{(H)}$, $V_{CC(L)}$ - $COM_{(L)}$	13.5	15	16.5	V
High-Side Bias Voltage	V_{BS}	Applied between $V_{B(U)}$ - $V_{S(U)}$, $V_{B(V)}$ - $V_{S(V)}$, $V_{B(W)}$ - $V_{S(W)}$	13.5	15	16.5	V
Blanking Time for Preventing Arm-short	t_{dead}	For Each Input Signal	3	-	-	us
PWM Input Signal	f_{PWM}	$T_C \leq 100^\circ C$, $T_J \leq 125^\circ C$	-	3	-	kHz
Input ON Threshold Voltage	$V_{IN(ON)}$	Applied between U_{IN} , V_{IN} , W_{IN} - COM	0 ~ 0.65			V
Input OFF Threshold Voltage	$V_{IN(OFF)}$	Applied between U_{IN} , V_{IN} , W_{IN} - COM	4 ~ 5.5			V

ICs Internal Structure and Input/Output Conditions



Note

1. One LVIC drives three Sense-IGBTs and can do short-circuit current protection also. Three sense emitters are commonly connected to R_{SC} terminal to detect short-circuit current. Low-side part of the inverter consists of three sense-IGBTs
2. One HVIC drives one normal-IGBT. High-side part of the inverter consists of three normal-IGBTs
3. Each IC has under voltage detection and protection function.
4. The logic input is compatible with standard CMOS or LSTTL outputs.
5. $R_P C_P$ coupling at each input/output is recommended in order to prevent the gating input/output signals oscillation and it should be as close as possible to each SPM gating input pin.
6. It would be recommended that the bootstrap diode, D_{BS} , has soft and fast recovery characteristics.

Fig. 10.

Time Charts of SPMs Protective Function

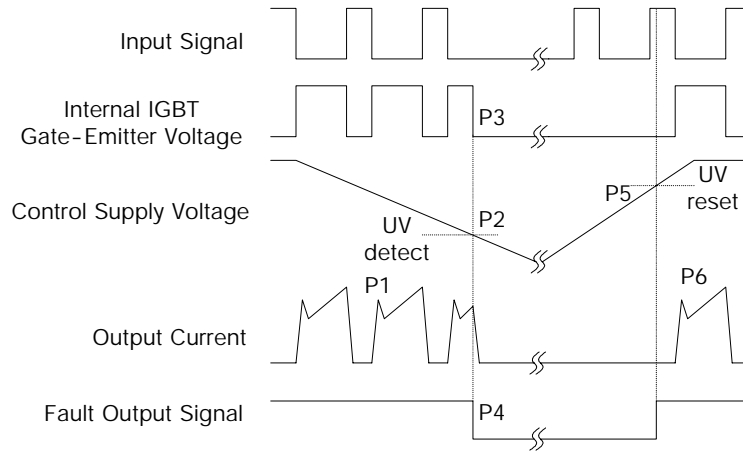

- P1 : Normal operation - IGBT ON and conducting current
- P2 : Under voltage detection
- P3 : IGBT gate interrupt
- P4 : Fault signal generation
- P5 : Under voltage reset
- P6 : Normal operation - IGBT ON and conducting current

Fig. 11. Under-Voltage Protection (Low-side)

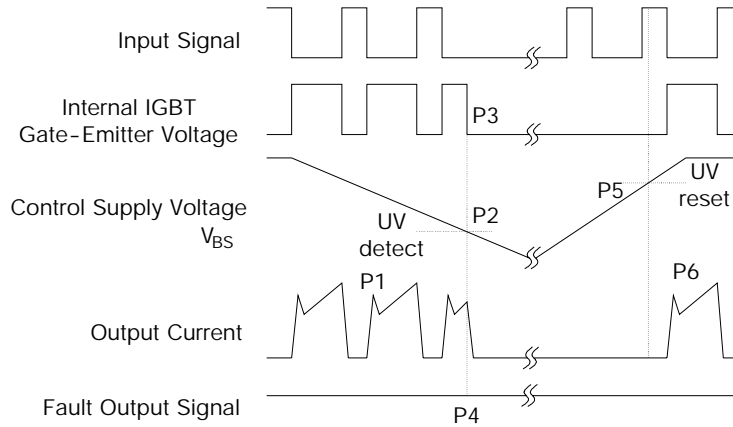

- P1 : Normal operation - IGBT ON and conducting current
- P2 : Under voltage detection
- P3 : IGBT gate interrupt
- P4 : No fault signal
- P5 : Under voltage reset
- P6 : Normal operation - IGBT ON and conducting current

Fig. 12. Under-Voltage Protection (High-side)

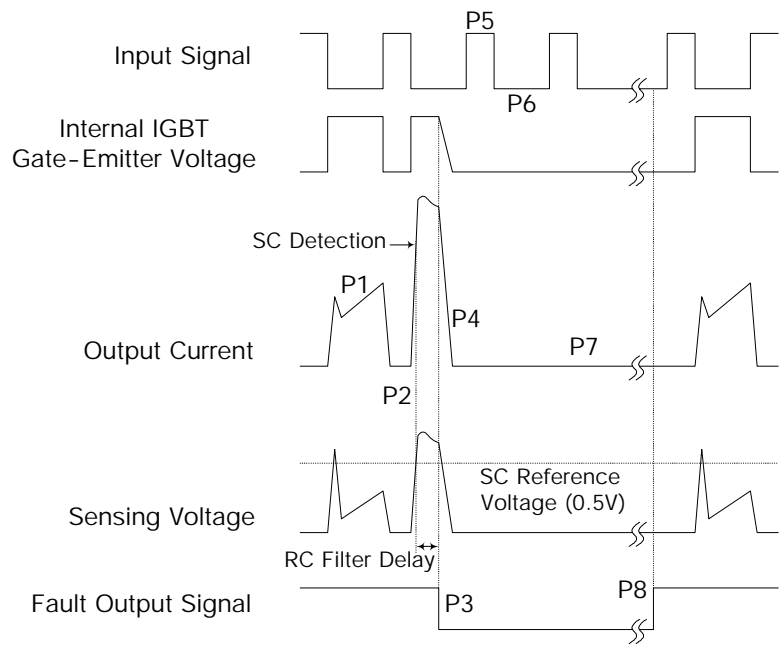

- P1 : Normal operation - IGBT ON and conducting currents
- P2 : Short-circuit current detection
- P3 : IGBT gate interrupt / Fault signal generation
- P4 : IGBT is slowly turned off
- P5 : IGBT OFF signal
- P6 : IGBT ON signal - but IGBT cannot be turned on during the fault-output activation
- P7 : IGBT OFF state
- P8 : Fault-output reset and normal operation start

Fig. 13. Short-circuit Current Protection (Low-side Operation only)

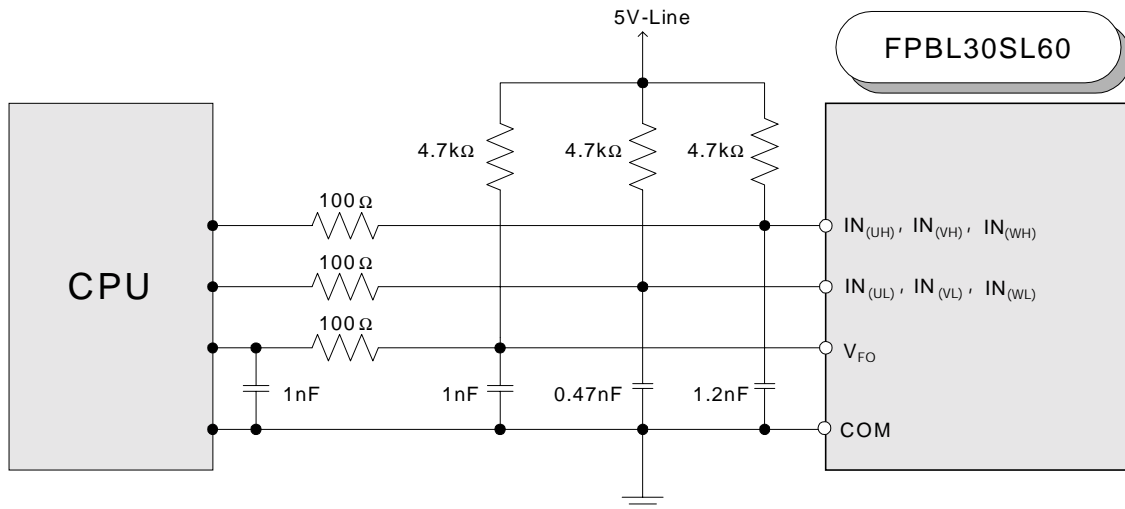

Note
 It would be recommended that by-pass capacitors for the gating input signals, $IN_{(xx)}$ should be placed on the SPM pins and on the both sides of CPU and SPM for the fault output signal, V_{FO} , as close as possible.

Fig. 14. Recommended CPU I/O Interface Circuit

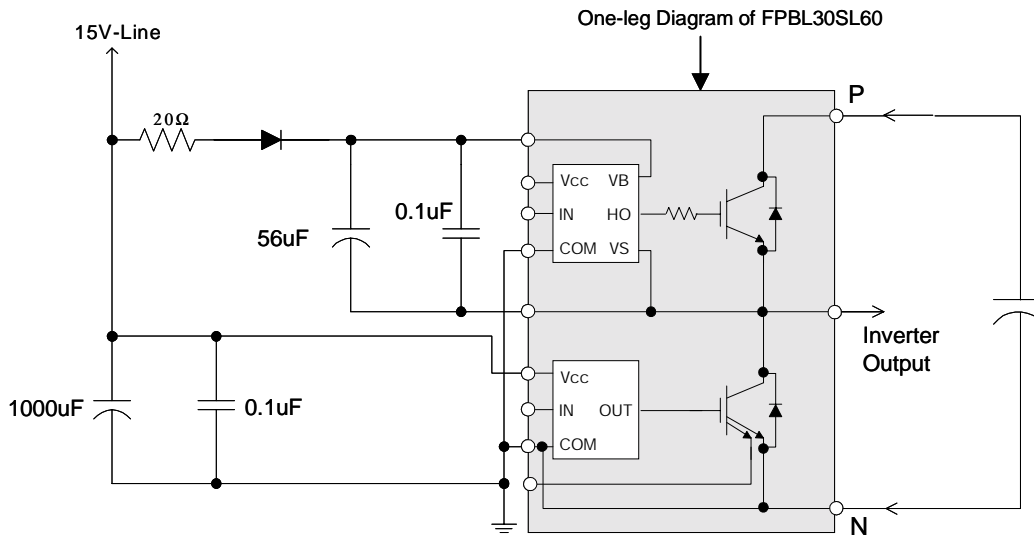
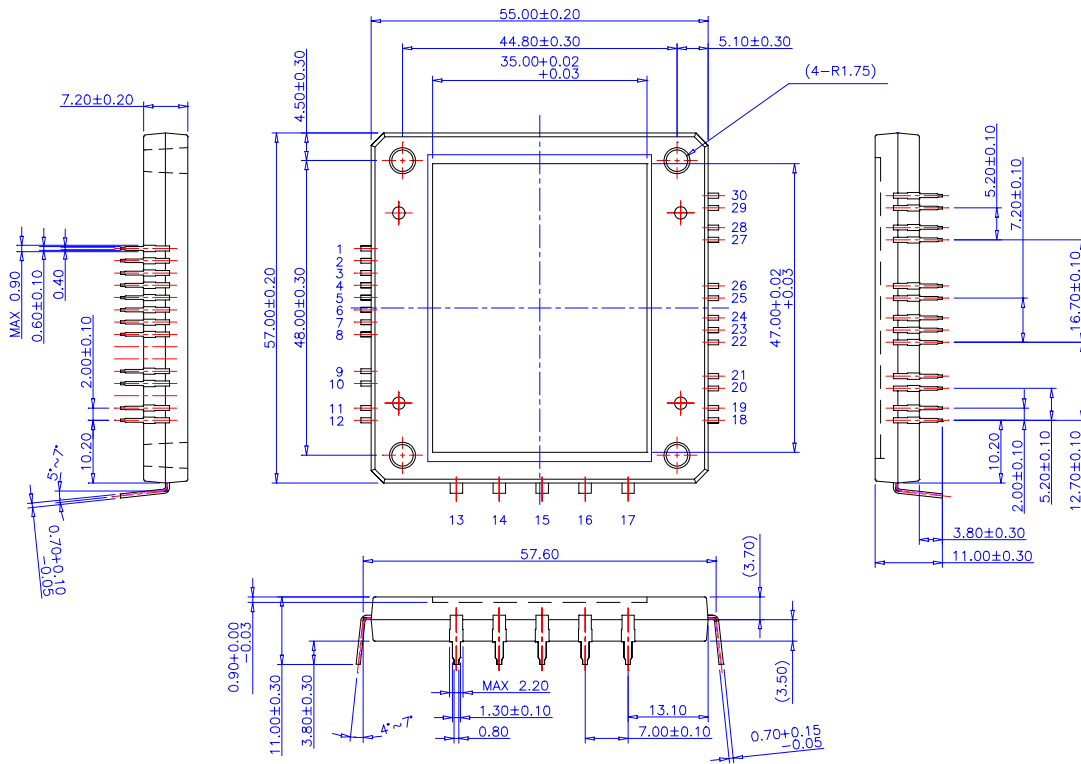

Fig. 15. Recommended Bootstrap Operation Circuit and Parameters

Detailed Package Outline Drawings



FPBL30SL60

TRADEMARKS

The following are registered and unregistered trademarks Fairchild Semiconductor owns or is authorized to use and is not intended to be an exhaustive list of all such trademarks.

ACE _x TM	FAST [®]	OPTOLOGIC TM	SMART START TM	VCX TM
Bottomless TM	FAST _r TM	OPTOPLANAR TM	STAR*POWER TM	
CoolFET TM	FRFET TM	PACMAN TM	Stealth TM	
CROSSVOLT TM	GlobalOptoisolator TM	POP TM	SuperSOT TM -3	
DenseTrench TM	GTO TM	Power247 TM	SuperSOT TM -6	
DO _M E TM	HiSeC TM	PowerTrench [®]	SuperSOT TM -8	
EcoSPARK TM	ISOPLANAR TM	QFET TM	SyncFET TM	
E ² CMOS TM	LittleFET TM	QS TM	TruTranslation TM	
EnSigna TM	MicroFET TM	QT Optoelectronics TM	TinyLogic TM	
FACT TM	MicroPak TM	Quiet Series TM	UHC TM	
FACT Quiet Series TM	MICROWIRE TM	SLIENT SWITCHER [®]	UltraFET [®]	

STAR*POWER is used under license

DISCLAIMER

FAIRCHILD SEMICONDUCTOR RESERVES THE RIGHT TO MAKE CHANGES WITHOUT FURTHER NOTICE TO ANY PRODUCTS HEREIN TO IMPROVE RELIABILITY, FUNCTION OR DESIGN. FAIRCHILD DOES NOT ASSUME ANY LIABILITY ARISING OUT OF THE APPLICATION OR USE OF ANY PRODUCT OR CIRCUIT DESCRIBED HEREIN; NEITHER DOES IT CONVEY ANY LICENSE UNDER ITS PATENT RIGHTS, NOR THE RIGHTS OF OTHERS.

LIFE SUPPORT POLICY

FAIRCHILD'S PRODUCTS ARE NOT AUTHORIZED FOR USE AS CRITICAL COMPONENTS IN LIFE SUPPORT DEVICES OR SYSTEMS WITHOUT THE EXPRESS WRITTEN APPROVAL OF FAIRCHILD SEMICONDUCTOR CORPORATION.

As used herein:

- Life support devices or systems are devices or systems which, (a) are intended for surgical implant into the body, or (b) support or sustain life, or (c) whose failure to perform when properly used in accordance with instructions for use provided in the labeling, can be reasonably expected to result in significant injury to the user.
- A critical component is any component of a life support device or system whose failure to perform can be reasonably expected to cause the failure of the life support device or system, or to affect its safety or effectiveness.

PRODUCT STATUS DEFINITIONS

Definition of Terms

Datasheet Identification	Product Status	Definition
Advance Information	Formative or In Design	This datasheet contains the design specifications for product development. Specifications may change in any manner without notice.
Preliminary	First Production	This datasheet contains preliminary data, and supplementary data will be published at a later date. Fairchild Semiconductor reserves the right to make changes at any time without notice in order to improve design.
No Identification Needed	Full Production	This datasheet contains final specifications. Fairchild Semiconductor reserves the right to make changes at any time without notice in order to improve design.
Obsolete	Not In Production	This datasheet contains specifications on a product that has been discontinued by Fairchild semiconductor. The datasheet is printed for reference information only.



LittleDiode supplies new, hard to find or obsolete electronic components and semiconductors all over the world.

With over two million different components listed you are sure to find the part you need.

Feel free to visit us today at our online store:

LittleDiode.com

Looking forward to providing you with the best possible service.